

INDOOR UNIT

No. OBB843
 REVISED EDITION-E

PARTS CATALOG

Models

- MFZ-KT25VG** - **E1**, **ET1**, **ER1**, **E2**, **ET2**, **E3**, **ET3**
- MFZ-KT35VG** - **E1**, **ET1**, **ER1**, **E2**, **ET2**, **E3**, **ET3**
- MFZ-KT50VG** - **E1**, **ET1**, **ER1**, **E2**, **ET2**, **E3**, **ET3**
- MFZ-KT60VG** - **E1**, **ET1**, **ER1**, **E2**, **ET2**, **E3**, **ET3**
- MFZ-KT25VGK** - **E1**, **ET1**
- MFZ-KT35VGK** - **E1**, **ET1**
- MFZ-KT50VGK** - **E1**, **ET1**
- MFZ-KT60VGK** - **E1**, **ET1**

CONTENTS

- 1. SERVICE PARTS LIST 2
- 2. OPTIONAL PARTS 22

SERVICE MANUAL (OBH843)

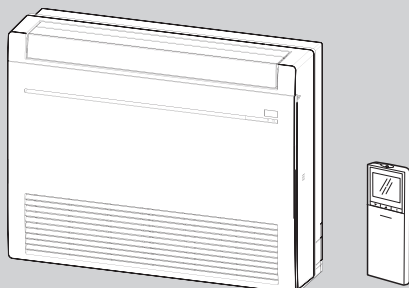

- MFZ-KT25VG MFZ-KT25VGK
- MFZ-KT35VG MFZ-KT35VGK
- MFZ-KT50VG MFZ-KT50VGK
- MFZ-KT60VG MFZ-KT60VGK

Revision A:

• MFZ-KT25/35/50/60VG-[ET1] have been added.

Revision B:

• MFZ-KT25/35/50/60VG-[ER1], [E2], [ET2] have been added.

Revision C:

• MFZ-KT25/35/50/60VG-[E3], [ET3] have been added.

Revision D:

• Model names of 1-12. have been corrected.

Revision E:

• MFZ-KT25/35/50/60VGK-[E1], [ET1] have been added.

1

SERVICE PARTS LIST

MFZ-KT25VG-[E1] [ET1] MFZ-KT35VG-[E1] [ET1] MFZ-KT50VG-[E1] [ET1] MFZ-KT60VG-[E1] [ET1]

1-1. INDOOR UNIT STRUCTURAL PARTS, HEAT EXCHANGER AND FUNCTIONAL PARTS

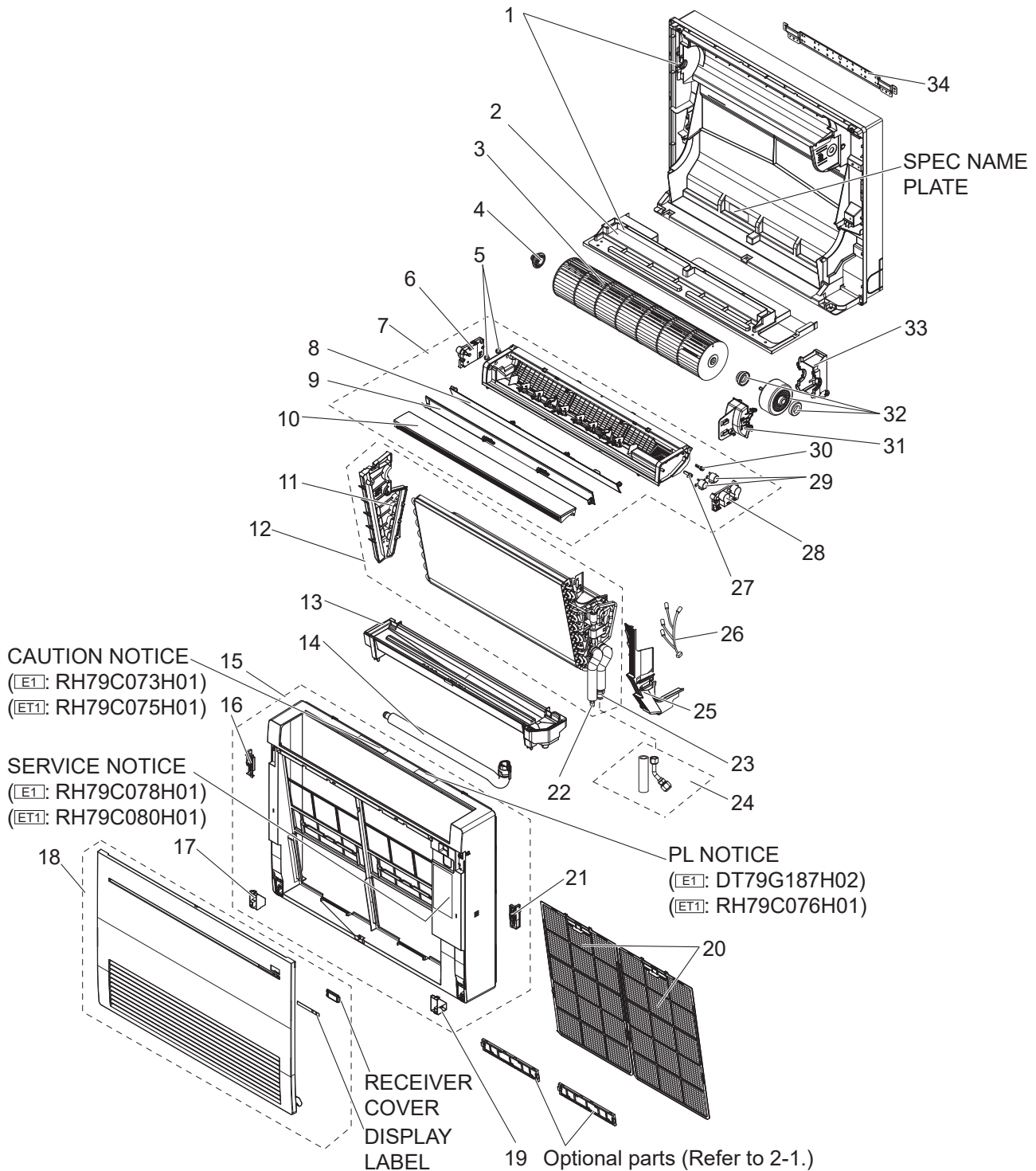

1-1. INDOOR UNIT STRUCTURAL PARTS, HEAT EXCHANGER AND FUNCTIONAL PARTS

1. The part quantity below indicates the required number of pieces per unit.
2. The circled No. indicates that the part is not shown in the figure.

No.	Part No.	Part Name	MFZ-KT25VG - [E1]	MFZ-KT25VG - [ET1]	MFZ-KT35VG - [E1]	MFZ-KT35VG - [ET1]	MFZ-KT50VG - [E1]	MFZ-KT50VG - [ET1]	MFZ-KT60VG - [E1]	MFZ-KT60VG - [ET1]	Symbol in Wiring Diagram	Remarks [Drawing No.]
1	M21 EBJ 234	BOX ASSEMBLY	1		1		1		1			Includes base without spec name plate
1	M21 EBK 234	BOX ASSEMBLY		1		1		1		1		Includes base without spec name plate [SQ25A544G07]
2	—	BASE	1	1	1	1	1	1	1	1		
3	M21 EAA 302	LINE FLOW FAN ASSEMBLY	1	1	1	1	1	1	1	1		
4	M21 EA3 509	BEARING ASSEMBLY	1	1	1	1	1	1	1	1		
5	M21 EA5 071	VANE SLEEVE	2	2	2	2	2	2	2	2		
6	M21 EA4 306	MULTI-FLOW VANE MOTOR UNIT	1	1	1	1	1	1	1	1	MV3	
7	M21 EAY 235	NOZZLE ASSEMBLY	1	1	1	1	1	1	1	1		
8	M21 EAA 040	VERTICAL VANE	1	1	1	1	1	1	1	1		
9	M21 EA9 040	HORIZONTAL VANE	1	1	1	1	1	1	1	1		
10	M21 EA8 040	MULTI-FLOW VANE	1	1	1	1	1	1	1	1		
11	—	HAIRPIN HOLDER ASSEMBLY	1	1	1	1	1	1	1	1		[DQ00T279G05]
12	M21 EJP 620	INDOOR HEAT EXCHANGER	1	1	1	1						
12	M21 EJR 620	INDOOR HEAT EXCHANGER					1	1				
12	M21 EJS 620	INDOOR HEAT EXCHANGER							1	1		
13	M21 EA5 700	DRAIN PAN ASSEMBLY	1	1	1	1	1	1	1	1		
14	M21 7K1 703	DRAIN HOSE ASSEMBLY	1	1	1	1	1	1	1	1		
15	T2W EC2 000	PANEL ASSEMBLY	1		1				1			Includes notice
15	T2W EC4 000	PANEL ASSEMBLY		1		1			1			Includes notice
16	M21 EA0 099	HOOK (LEFT) ASSEMBLY	1	1	1	1	1	1	1	1		
17	M21 EA8 039	ARM HOLDER (LEFT)	1	1	1	1	1	1	1	1		
18	M21 EBR 010	FRONT PANEL	1	1	1	1	1	1	1	1		Includes receiver cover and display label
19	M21 EA9 039	ARM HOLDER (RIGHT)	1	1	1	1	1	1	1	1		
20	M21 EAS 100	AIR PURIFYING FILTER	2	2	2	2	2	2	2	2		
21	M21 EA1 099	HOOK (RIGHT) ASSEMBLY	1	1	1	1	1	1	1	1		
22	M21 L3V 664	UNION (LIQ)	1	1	1	1	1	1	1	1		ø6.35
23	M21 L3V 663	UNION (GAS)	1	1	1	1						ø9.52
23	M21 L5V 663	UNION (GAS)					1	1				ø12.7
24	T2W EA1 938	JOINT PIPE							1	1		
25	—	WATER COVER	1	1	1	1	1	1	1	1		[DQ00T288G04]
26	M21 EBF 305	INDOOR COIL THERMISTOR	1	1	1	1	1	1			RT12, RT13	
26	M21 EA9 305	INDOOR COIL THERMISTOR							1	1	RT12, RT13, RT14, RT15	
27	M21 EA5 049	HORIZONTAL VANE MOTOR SHAFT	1	1	1	1	1	1	1	1		
28	M21 EA1 506	VANE MOTOR SUPPORT	1	1	1	1	1	1	1	1		
29	M21 EA5 306	VANE MOTOR	2	2	2	2	2	2	2	2	MV1, MV2	
30	M21 EA6 049	VERTICAL VANE MOTOR SHAFT	1	1	1	1	1	1	1	1		
31	M21 EA3 023	MOTOR BAND	1	1	1	1	1	1	1	1		
32	M21 EDD 300	INDOOR FAN MOTOR ASSEMBLY	1	1	1	1					MF	RC0J30-□□
32	M21 EAM 300	INDOOR FAN MOTOR ASSEMBLY					1	1	1	1	MF	RC0J40-□□
33	M21 EA3 791	MOTOR BED	1	1	1	1	1	1	1	1		
34	T2W L3V 233	BACK PLATE	1	1	1	1	1	1	1	1		
③⑤	—	LEAD WIRE ASSEMBLY	1	1	1	1	1	1	1	1		[DY00C344G04] To terminal block
③⑥	—	LEAD WIRE ASSEMBLY	1	1	1	1	1	1	1	1		[DY00C346G03] To vane motor
③⑦	—	LEAD WIRE ASSEMBLY	1	1	1	1	1	1	1	1		[DY00C345G03] To display receiver P.C. board
③⑧	—	LEAD WIRE ASSEMBLY	1	1	1	1	1	1	1	1		[RH78C059G01] To R32 sensor

MFZ-KT25VG - [E1] [ET1] MFZ-KT35VG - [E1] [ET1] MFZ-KT50VG - [E1] [ET1] MFZ-KT60VG - [E1] [ET1]
1-2. INDOOR UNIT ELECTRICAL PARTS

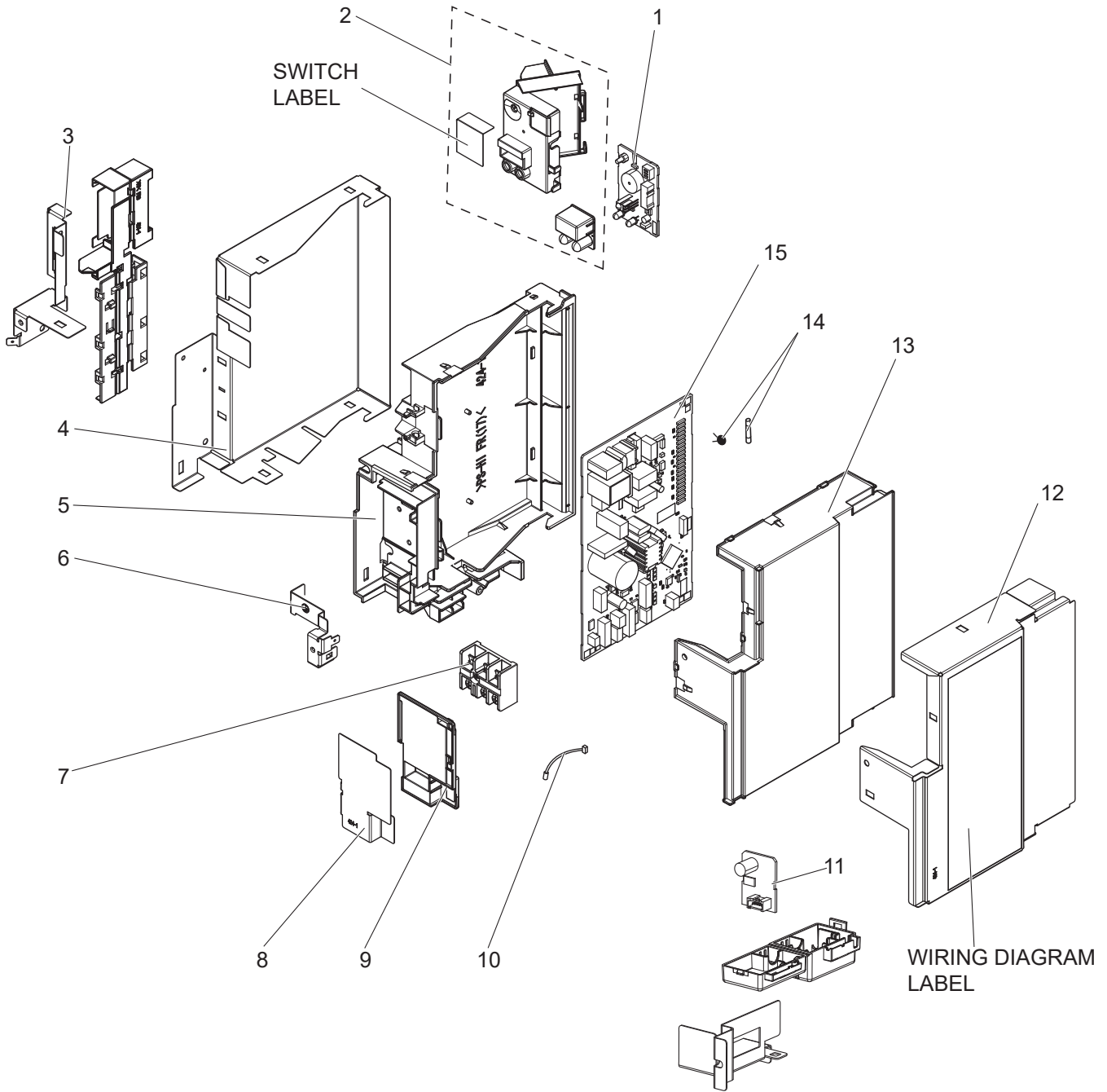

1-3. ACCESSORY AND REMOTE CONTROLLER

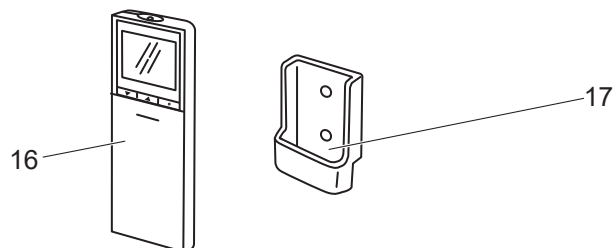

1-2. INDOOR UNIT ELECTRICAL PARTS

1. The part quantity below indicates the required number of pieces per unit.

No.	Part No.	Part Name	MFZ-KT25VG - [E1]	MFZ-KT25VG - [ET1]	MFZ-KT35VG - [E1]	MFZ-KT35VG - [ET1]	MFZ-KT50VG - [E1]	MFZ-KT50VG - [ET1]	MFZ-KT60VG - [E1]	MFZ-KT60VG - [ET1]	Symbol in Wiring Diagram	Remarks [Drawing No.]
1	T2W EA7 328	DISPLAY RECEIVER P.C. BOARD	1	1	1	1	1	1	1	1		
2	T2W EAJ 012	SWITCH HOLDER SET	1	1	1	1	1	1	1	1		Includes switch label
3	—	TB COVER	1	1	1	1	1	1	1	1		[DY02B654G01]
4	—	PB COVER LEFT	1	1	1	1	1	1	1	1		[DY02A632G03]
5	—	PB BOX	1	1	1	1	1	1	1	1		[DY25A631G06]
6	—	EARTH PLATE	1	1	1	1	1	1	1	1		[DY02B655G02]
7	M21 EA3 376	TERMINAL BLOCK	1	1	1	1	1	1	1	1	TB	
8	—	VA CLAMP COVER	1	1	1	1	1	1	1	1		[DK02B679G02]
9	—	VA CLAMP	1	1	1	1	1	1	1	1		[DK25B680G03]
10	M21 EAA 305	ROOM TEMPERATURE THERMISTOR	1	1	1	1	1	1	1	1	RT11	
11	M21 EA0 334	R32 SENSOR	1	1	1	1	1	1	1	1		
12	—	PB COVER RIGHT	1	1	1	1	1	1	1	1		[DK02A696G01] Without wiring diagram label
13	—	PB COVER	1	1	1	1	1	1	1	1		[DK25A695G01]
14	M21 EA5 313	FUSE VARISTOR SET	1	1	1	1	1	1	1	1	F11/NR11	T3.15AL250V
15	T2W F7Y 450	ELECTRONIC CONTROL P.C. BOARD	1	1								
15	T2W F80 450	ELECTRONIC CONTROL P.C. BOARD			1	1						
15	T2W F81 450	ELECTRONIC CONTROL P.C. BOARD					1	1				
15	T2W F82 450	ELECTRONIC CONTROL P.C. BOARD							1	1		

1-3. ACCESSORY AND REMOTE CONTROLLER

1. The part quantity below indicates the required number of pieces per unit.

No.	Part No.	Part Name	MFZ-KT25VG - [E1]	MFZ-KT25VG - [ET1]	MFZ-KT35VG - [E1]	MFZ-KT35VG - [ET1]	MFZ-KT50VG - [E1]	MFZ-KT50VG - [ET1]	MFZ-KT60VG - [E1]	MFZ-KT60VG - [ET1]	Symbol in Wiring Diagram	Remarks
16	T2W EFF 426	REMOTE CONTROLLER	1	1	1	1	1	1	1	1		SG191
17	T2W EA0 083	REMOTE CONTROLLER HOLDER	1	1	1	1	1	1	1	1		

MFZ-KT25VG -(ER1) MFZ-KT35VG -(ER1) MFZ-KT50VG -(ER1) MFZ-KT60VG -(ER1)

1-4. INDOOR UNIT STRUCTURAL PARTS, HEAT EXCHANGER AND FUNCTIONAL PARTS

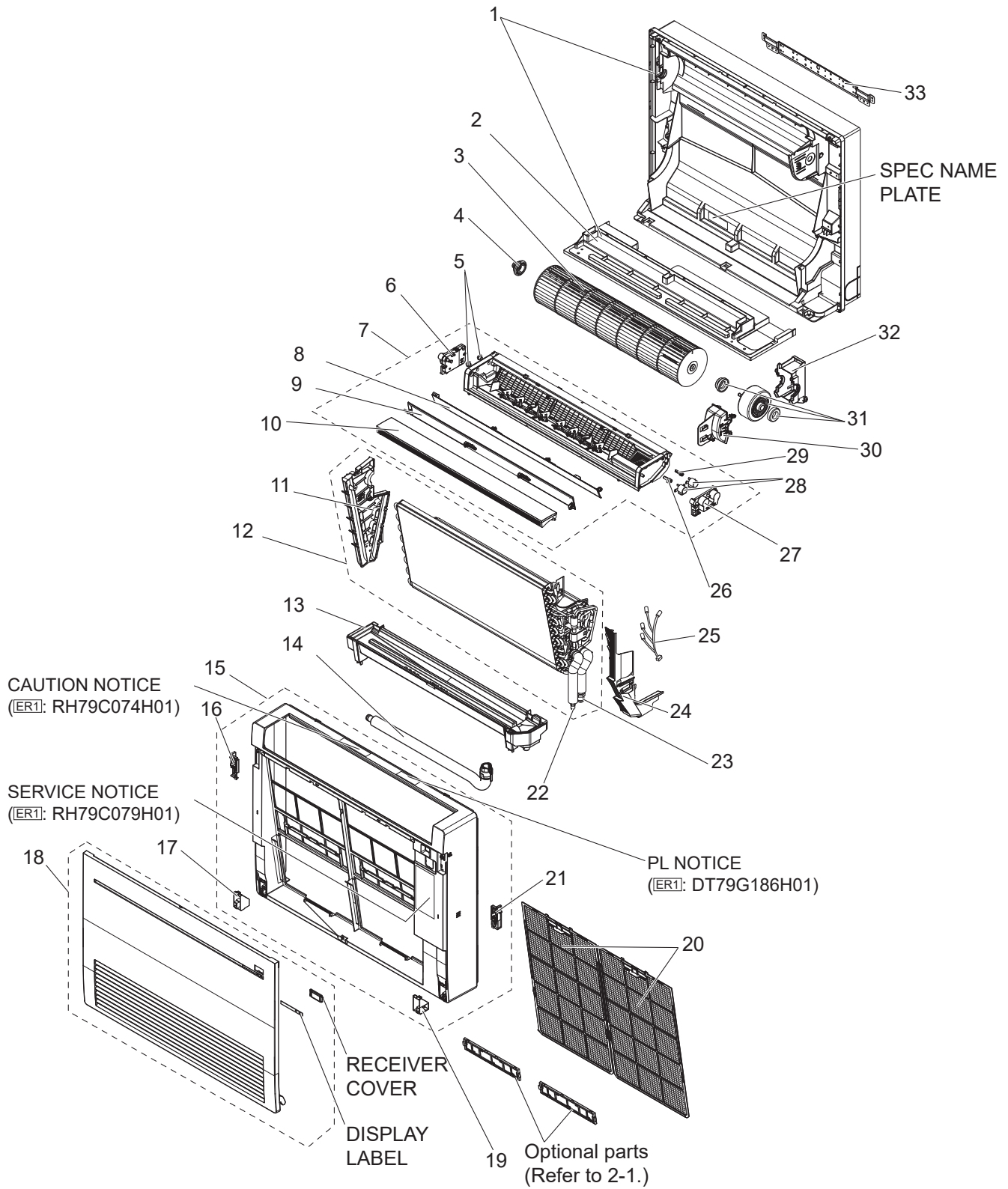

1-4. INDOOR UNIT STRUCTURAL PARTS, HEAT EXCHANGER AND FUNCTIONAL PARTS

1. The part quantity below indicates the required number of pieces per unit.

2. The circled No. indicates that the part is not shown in the figure.

No.	Part No.	Part Name	MFZ-KT25VG - [ERT]	MFZ-KT35VG - [ERT]	MFZ-KT50VG - [ERT]	MFZ-KT60VG - [ERT]	Symbol in Wiring Diagram	Remarks [Drawing No.]
1	M21 EC3 234	BOX ASSEMBLY	1	1	1	1		Includes base without spec name plate
2	—	BASE	1	1	1	1		[SQ25A544G07]
3	M21 EAA 302	LINE FLOW FAN ASSEMBLY	1	1	1	1		
4	M21 EA3 509	BEARING ASSEMBLY	1	1	1	1		
5	M21 EA5 071	VANE SLEEVE	2	2	2	2		
6	M21 EA4 306	MULTI-FLOW VANE MOTOR UNIT	1	1	1	1	MV3	
7	M21 EAY 235	NOZZLE ASSEMBLY	1	1	1	1		
8	M21 EAA 040	VERTICAL VANE	1	1	1	1		
9	M21 EA9 040	HORIZONTAL VANE	1	1	1	1		
10	M21 EA8 040	MULTI-FLOW VANE	1	1	1	1		
11	—	HAIRPIN HOLDER ASSEMBLY	1	1	1	1		[DQ00T279G05]
12	M21 EJP 620	INDOOR HEAT EXCHANGER	1	1				
12	M21 EJR 620	INDOOR HEAT EXCHANGER			1			
12	M21 EJS 620	INDOOR HEAT EXCHANGER				1		
13	M21 EA5 700	DRAIN PAN ASSEMBLY	1	1	1	1		
14	M21 7K1 703	DRAIN HOSE ASSEMBLY	1	1	1	1		
15	T2W EC3 000	PANEL ASSEMBLY	1	1	1	1		Includes notice
16	M21 EA0 099	HOOK (LEFT) ASSEMBLY	1	1	1	1		
17	M21 EA8 039	ARM HOLDER (LEFT)	1	1	1	1		
18	M21 EBR 010	FRONT PANEL	1	1	1	1		Includes receiver cover and display label
19	M21 EA9 039	ARM HOLDER (RIGHT)	1	1	1	1		
20	M21 EAS 100	AIR PURIFYING FILTER	2	2	2	2		
21	M21 EA1 099	HOOK (RIGHT) ASSEMBLY	1	1	1	1		
22	M21 L3V 664	UNION (LIQ)	1	1	1	1		ø6.35
23	M21 L3V 663	UNION (GAS)	1	1				ø9.52
23	M21 L5V 663	UNION (GAS)			1	1		ø12.7
24	—	WATER COVER	1	1	1	1		[DQ00T288G04]
25	M21 EBF 305	INDOOR COIL THERMISTOR	1	1	1		RT12, RT13	
25	M21 EA9 305	INDOOR COIL THERMISTOR				1	RT12, RT13, RT14, RT15	
26	M21 EA5 049	HORIZONTAL VANE MOTOR SHAFT	1	1	1	1		
27	M21 EA1 506	VANE MOTOR SUPPORT	1	1	1	1		
28	M21 EA5 306	VANE MOTOR	2	2	2	2	MV1, MV2	
29	M21 EA6 049	VERTICAL VANE MOTOR SHAFT	1	1	1	1		
30	M21 EA3 023	MOTOR BAND	1	1	1	1		
31	M21 EDD 300	INDOOR FAN MOTOR ASSEMBLY	1	1			MF	RC0J30-□□
31	M21 EAM 300	INDOOR FAN MOTOR ASSEMBLY			1	1	MF	RC0J40-□□
32	M21 EA3 791	MOTOR BED	1	1	1	1		
33	T2W L3V 233	BACK PLATE	1	1	1	1		
③④	—	LEAD WIRE ASSEMBLY	1	1	1	1		[DY00C344G04] To terminal block
③⑤	—	LEAD WIRE ASSEMBLY	1	1	1	1		[DY00C346G03] To vane motor
③⑥	—	LEAD WIRE ASSEMBLY	1	1	1	1		[DY00C345G03] To display receiver P.C. board
③⑦	—	LEAD WIRE ASSEMBLY	1	1	1	1		[RH78C059G01] To R32 sensor

MFZ-KT25VG-ER1 MFZ-KT35VG-ER1 MFZ-KT50VG-ER1 MFZ-KT60VG-ER1
1-5. INDOOR UNIT ELECTRICAL PARTS

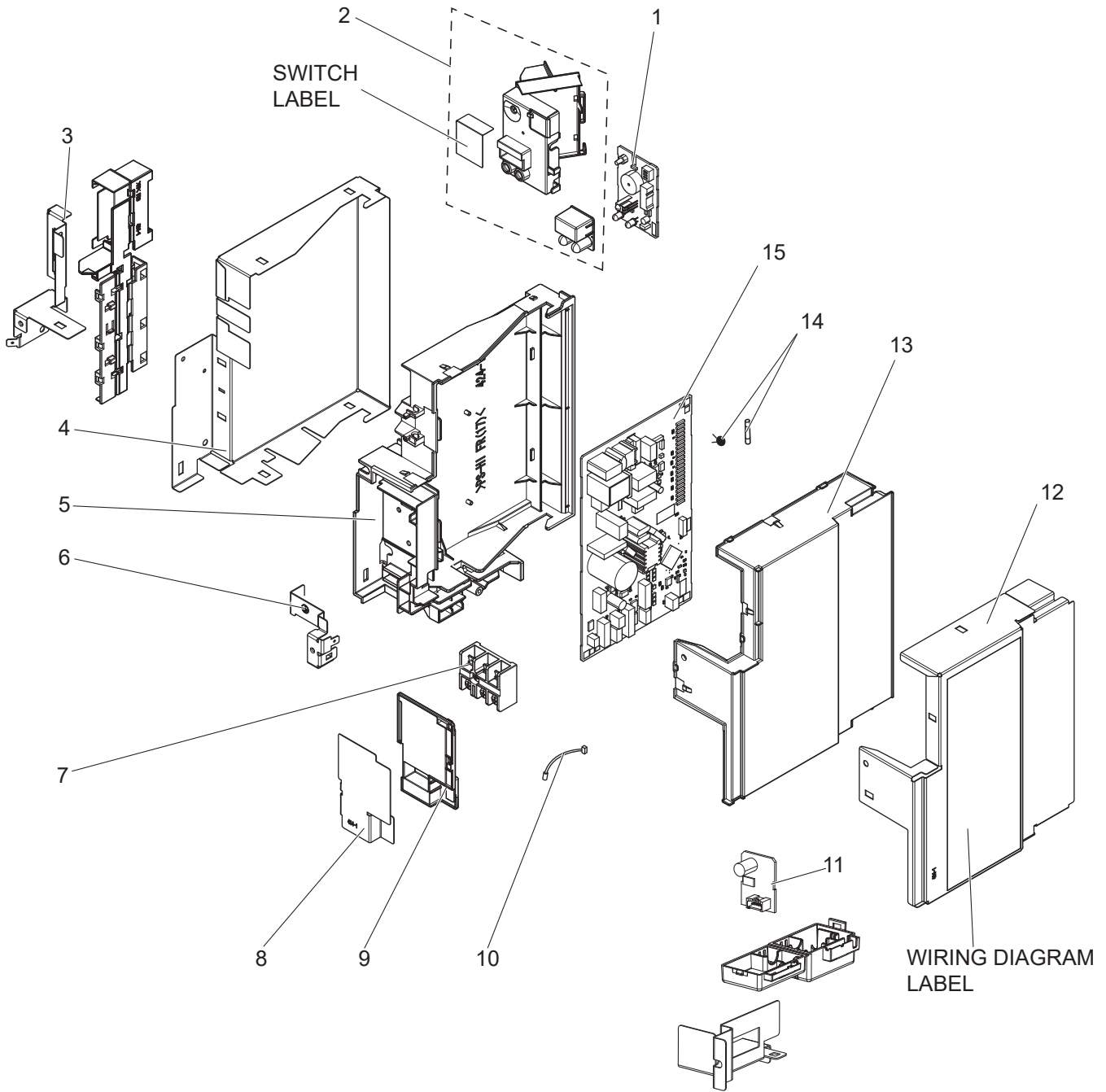

1-6. ACCESSORY AND REMOTE CONTROLLER

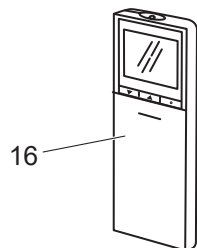

1-5. INDOOR UNIT ELECTRICAL PARTS

1. The part quantity below indicates the required number of pieces per unit.

No.	Part No.	Part Name	MFZ-KT25VG- ^[ER1]	MFZ-KT35VG- ^[ER1]	MFZ-KT50VG- ^[ER1]	MFZ-KT60VG- ^[ER1]	Symbol in Wiring Diagram	Remarks [Drawing No.]
1	T2W EBE 328	DISPLAY RECEIVER P.C. BOARD ASSEMBLY	1	1	1	1		
2	T2W EAJ 012	SWITCH HOLDER SET	1	1	1	1		Includes switch label
3	—	TB COVER	1	1	1	1		[DY02B654G01]
4	—	PB COVER LEFT	1	1	1	1		[DY02A632G03]
5	—	PB BOX	1	1	1	1		[DY25A631G06]
6	—	EARTH PLATE	1	1	1	1		[DY02B655G02]
7	M21 EA3 376	TERMINAL BLOCK	1	1	1	1	TB	
8	—	VA CLAMP COVER	1	1	1	1		[DK02B679G02]
9	—	VA CLAMP	1	1	1	1		[DK25B680G03]
10	M21 EAA 305	ROOM TEMPERATURE THERMISTOR	1	1	1	1	RT11	
11	M21 EA1 334	R32 SENSOR	1	1	1	1		
12	—	PB COVER RIGHT	1	1	1	1		[DK02A696G01] Without wiring diagram label
13	—	PB COVER	1	1	1	1		[DK25A695G01]
14	M21 EA5 313	FUSE VARISTOR SET	1	1	1	1	F11/NR11	T3.15AL250V
15	T2W FEA 450	ELECTRONIC CONTROL P.C. BOARD	1					
15	T2W FEC 450	ELECTRONIC CONTROL P.C. BOARD		1				
15	T2W FED 450	ELECTRONIC CONTROL P.C. BOARD			1			
15	T2W FEE 450	ELECTRONIC CONTROL P.C. BOARD				1		

1-6. ACCESSORY AND REMOTE CONTROLLER

1. The part quantity below indicates the required number of pieces per unit.

No.	Part No.	Part Name	MFZ-KT25VG- ^[ER1]	MFZ-KT35VG- ^[ER1]	MFZ-KT50VG- ^[ER1]	MFZ-KT60VG- ^[ER1]	Symbol in Wiring Diagram	Remarks
16	T2W EGA 426	REMOTE CONTROLLER ASSEMBLY	1	1	1	1		SG191

MFZ-KT25VG - [E2] [ET2] MFZ-KT35VG - [E2] [ET2] MFZ-KT50VG - [E2] [ET2] MFZ-KT60VG - [E2] [ET2]
1-7. INDOOR UNIT STRUCTURAL PARTS, HEAT EXCHANGER AND FUNCTIONAL PARTS

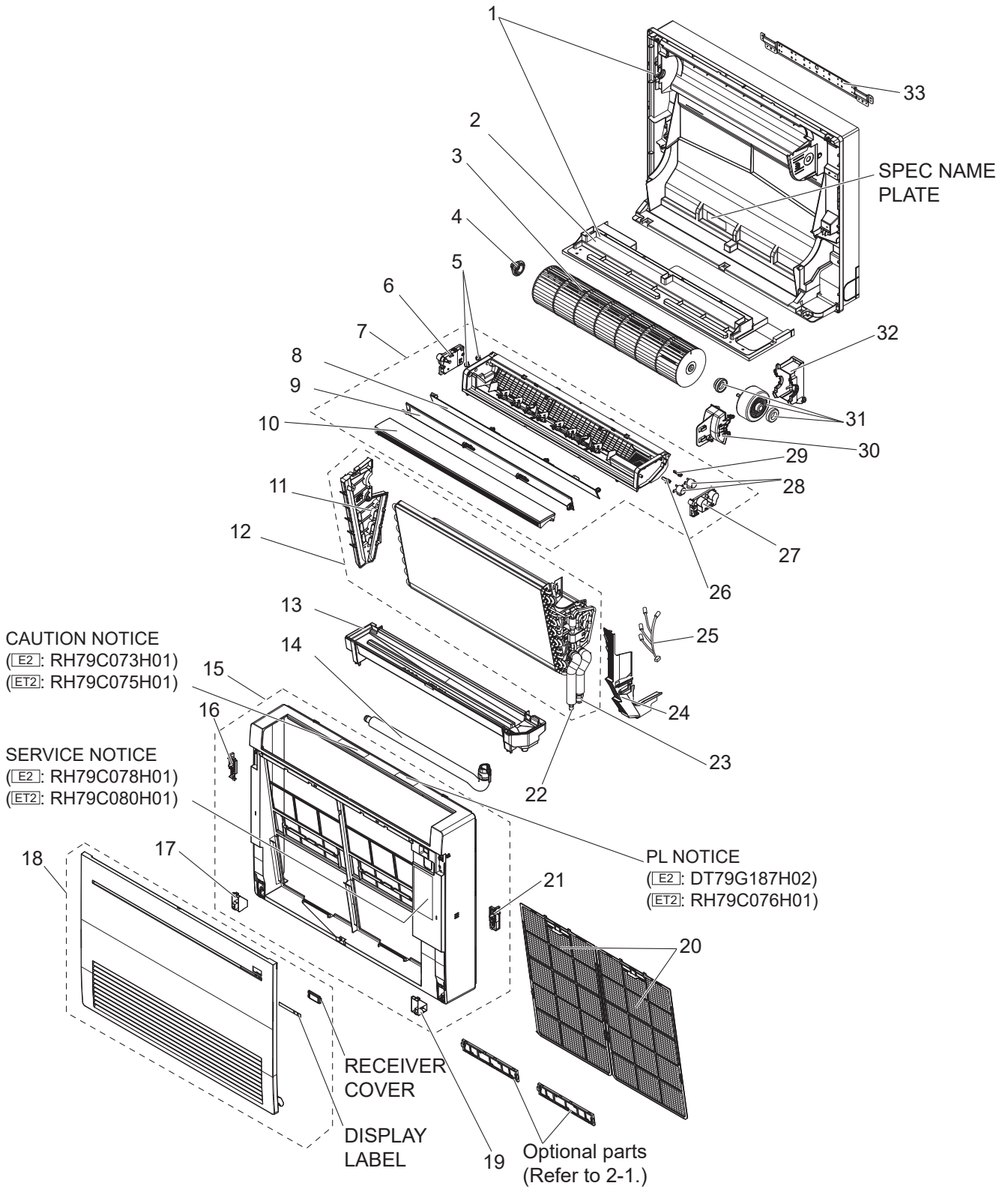

1-7. INDOOR UNIT STRUCTURAL PARTS, HEAT EXCHANGER AND FUNCTIONAL PARTS

1. The part quantity below indicates the required number of pieces per unit.
2. The circled No. indicates that the part is not shown in the figure.

No.	Part No.	Part Name	MFZ-KT25VG - [E2]	MFZ-KT25VG - [ET2]	MFZ-KT35VG - [E2]	MFZ-KT35VG - [ET2]	MFZ-KT50VG - [E2]	MFZ-KT50VG - [ET2]	MFZ-KT60VG - [E2]	MFZ-KT60VG - [ET2]	Symbol in Wiring Diagram	Remarks [Drawing No.]
1	M21 EBJ 234	BOX ASSEMBLY	1		1		1		1			Includes base without spec name plate
1	M21 EBK 234	BOX ASSEMBLY		1		1		1		1		Includes base without spec name plate [SQ25A544G07]
2	—	BASE	1	1	1	1	1	1	1	1		
3	M21 EAA 302	LINE FLOW FAN ASSEMBLY	1	1	1	1	1	1	1	1		
4	M21 EA3 509	BEARING ASSEMBLY	1	1	1	1	1	1	1	1		
5	M21 EA5 071	VANE SLEEVE	2	2	2	2	2	2	2	2		
6	M21 EA4 306	MULTI-FLOW VANE MOTOR UNIT	1	1	1	1	1	1	1	1	MV3	
7	M21 EAY 235	NOZZLE ASSEMBLY	1	1	1	1	1	1	1	1		
8	M21 EAA 040	VERTICAL VANE	1	1	1	1	1	1	1	1		
9	M21 EA9 040	HORIZONTAL VANE	1	1	1	1	1	1	1	1		
10	M21 EA8 040	MULTI-FLOW VANE	1	1	1	1	1	1	1	1		
11	—	HAIRPIN HOLDER ASSEMBLY	1	1	1	1	1	1	1	1		[DQ00T279G05]
12	M21 EJP 620	INDOOR HEAT EXCHANGER	1	1	1	1						
12	M21 EJR 620	INDOOR HEAT EXCHANGER					1	1				
12	M21 EJS 620	INDOOR HEAT EXCHANGER							1	1		
13	M21 EA5 700	DRAIN PAN ASSEMBLY	1	1	1	1	1	1	1	1		
14	M21 7K1 703	DRAIN HOSE ASSEMBLY	1	1	1	1	1	1	1	1		
15	T2W EC2 000	PANEL ASSEMBLY	1		1				1			Includes notice
15	T2W E43 000	PANEL ASSEMBLY		1		1		1		1		Includes notice
16	M21 EA0 099	HOOK (LEFT) ASSEMBLY	1	1	1	1	1	1	1	1		
17	M21 EA8 039	ARM HOLDER (LEFT)	1	1	1	1	1	1	1	1		
18	M21 EBR 010	FRONT PANEL	1	1	1	1	1	1	1	1		Includes receiver cover and display label
19	M21 EA9 039	ARM HOLDER (RIGHT)	1	1	1	1	1	1	1	1		
20	M21 EAS 100	AIR PURIFYING FILTER	2	2	2	2	2	2	2	2		
21	M21 EA1 099	HOOK (RIGHT) ASSEMBLY	1	1	1	1	1	1	1	1		
22	M21 L3V 664	UNION (LIQ)	1	1	1	1	1	1	1	1		ø6.35
23	M21 L3V 663	UNION (GAS)	1	1	1	1						ø9.52
23	M21 L5V 663	UNION (GAS)					1	1	1	1		ø12.7
24	—	WATER COVER	1	1	1	1	1	1	1	1		[DQ00T288G04]
25	M21 EBF 305	INDOOR COIL THERMISTOR	1	1	1	1	1	1			RT12, RT13	
25	M21 EA9 305	INDOOR COIL THERMISTOR							1	1	RT12, RT13, RT14, RT15	
26	M21 EA5 049	HORIZONTAL VANE MOTOR SHAFT	1	1	1	1	1	1	1	1		
27	M21 EA1 506	VANE MOTOR SUPPORT	1	1	1	1	1	1	1	1		
28	M21 EA5 306	VANE MOTOR	2	2	2	2	2	2	2	2	MV1, MV2	
29	M21 EA6 049	VERTICAL VANE MOTOR SHAFT	1	1	1	1	1	1	1	1		
30	M21 EA3 023	MOTOR BAND	1	1	1	1	1	1	1	1		
31	M21 EDD 300	INDOOR FAN MOTOR ASSEMBLY	1	1	1	1					MF	RC0J30-□□
31	M21 EAM 300	INDOOR FAN MOTOR ASSEMBLY					1	1	1	1	MF	RC0J40-□□
32	M21 EA3 791	MOTOR BED	1	1	1	1	1	1	1	1		
33	T2W L3V 233	BACK PLATE	1	1	1	1	1	1	1	1		
③④	—	LEAD WIRE ASSEMBLY	1	1	1	1	1	1	1	1		[DY00C344G04] To terminal block
③⑤	—	LEAD WIRE ASSEMBLY	1	1	1	1	1	1	1	1		[DY00C346G03] To vane motor
③⑥	—	LEAD WIRE ASSEMBLY	1	1	1	1	1	1	1	1		[DY00C345G03] To display receiver P.C. board
③⑦	—	LEAD WIRE ASSEMBLY	1	1	1	1	1	1	1	1		[RH78C059G01] To R32 sensor

MFZ-KT25VG - [E2] [ET2] MFZ-KT35VG - [E2] [ET2] MFZ-KT50VG - [E2] [ET2] MFZ-KT60VG - [E2] [ET2]
1-8. INDOOR UNIT ELECTRICAL PARTS

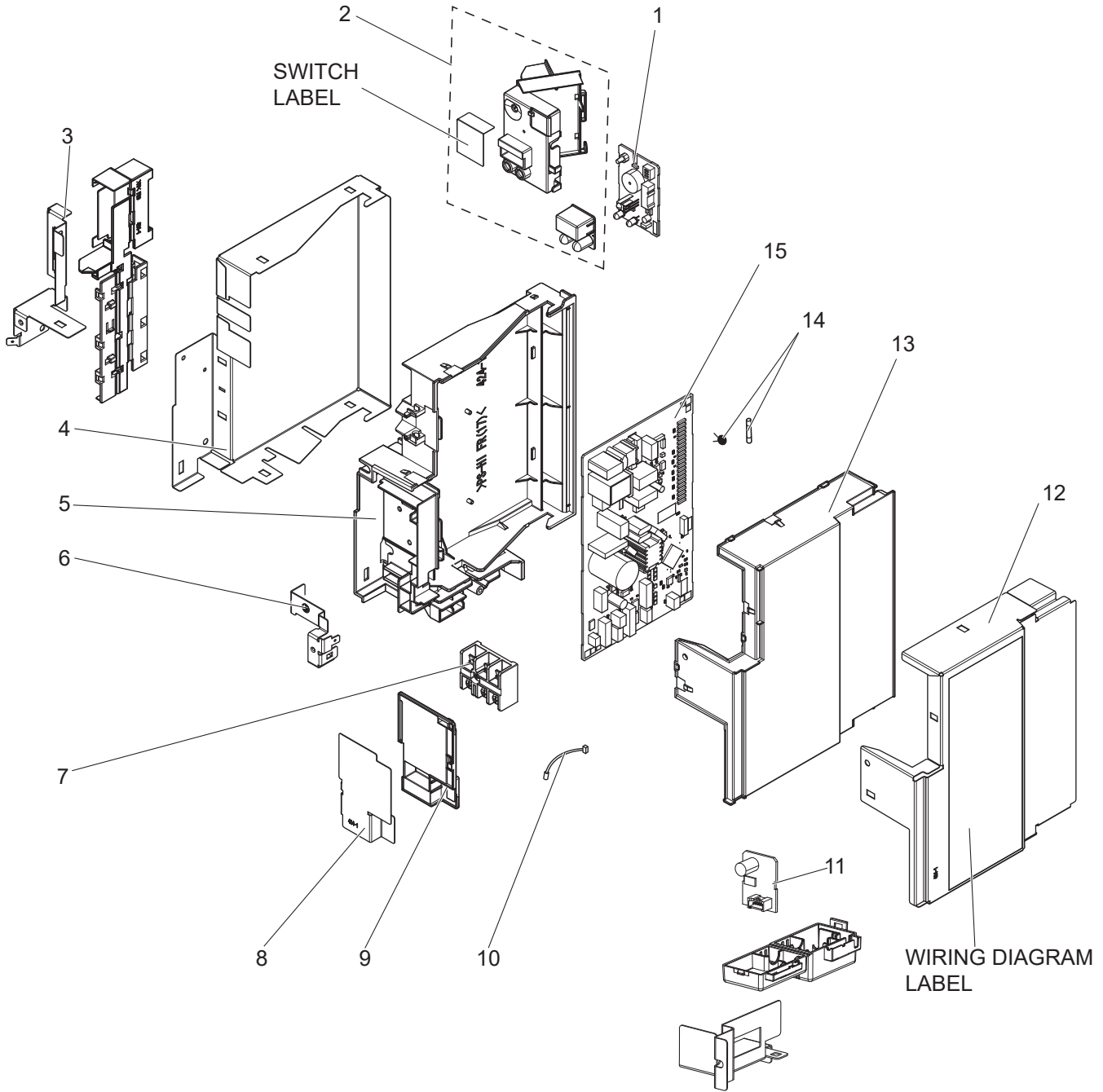

1-9. ACCESSORY AND REMOTE CONTROLLER

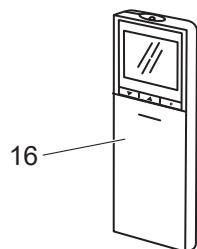

1-8. INDOOR UNIT ELECTRICAL PARTS

1. The part quantity below indicates the required number of pieces per unit.

No.	Part No.	Part Name	MFZ-KT25VG - [E2]	MFZ-KT25VG - [ET2]	MFZ-KT35VG - [E2]	MFZ-KT35VG - [ET2]	MFZ-KT50VG - [E2]	MFZ-KT50VG - [ET2]	MFZ-KT60VG - [E2]	MFZ-KT60VG - [ET2]	Symbol in Wiring Diagram	Remarks [Drawing No.]
1	T2W EBE 328	DISPLAY RECEIVER P.C. BOARD ASSEMBLY	1	1	1	1	1	1	1	1		
2	T2W EAJ 012	SWITCH HOLDER SET	1	1	1	1	1	1	1	1		Includes switch label
3	—	TB COVER	1	1	1	1	1	1	1	1		[DY02B654G01]
4	—	PB COVER LEFT	1	1	1	1	1	1	1	1		[DY02A632G03]
5	—	PB BOX	1	1	1	1	1	1	1	1		[DY25A631G06]
6	—	EARTH PLATE	1	1	1	1	1	1	1	1		[DY02B655G02]
7	M21 EA3 376	TERMINAL BLOCK	1	1	1	1	1	1	1	1	TB	
8	—	VA CLAMP COVER	1	1	1	1	1	1	1	1		[DK02B679G02]
9	—	VA CLAMP	1	1	1	1	1	1	1	1		[DK25B680G03]
10	M21 EAA 305	ROOM TEMPERATURE THERMISTOR	1	1	1	1	1	1	1	1	RT11	
11	M21 EA1 334	R32 SENSOR	1	1	1	1	1	1	1	1		
12	—	PB COVER RIGHT	1	1	1	1	1	1	1	1		[DK02A696G01] Without wiring diagram label
13	—	PB COVER	1	1	1	1	1	1	1	1		[DK25A695G01]
14	M21 EA5 313	FUSE VARISTOR SET	1	1	1	1	1	1	1	1	F11/NR11	T3.15AL250V
15	T2W FEA 450	ELECTRONIC CONTROL P.C. BOARD	1	1								
15	T2W FEC 450	ELECTRONIC CONTROL P.C. BOARD			1	1						
15	T2W FED 450	ELECTRONIC CONTROL P.C. BOARD					1	1				
15	T2W FEE 450	ELECTRONIC CONTROL P.C. BOARD							1	1		

1-9. ACCESSORY AND REMOTE CONTROLLER

1. The part quantity below indicates the required number of pieces per unit.

No.	Part No.	Part Name	MFZ-KT25VG - [E2]	MFZ-KT25VG - [ET2]	MFZ-KT35VG - [E2]	MFZ-KT35VG - [ET2]	MFZ-KT50VG - [E2]	MFZ-KT50VG - [ET2]	MFZ-KT60VG - [E2]	MFZ-KT60VG - [ET2]	Symbol in Wiring Diagram	Remarks
16	T2W EGA 426	REMOTE CONTROLLER ASSEMBLY	1	1	1	1	1	1	1	1		SG191

MFZ-KT25VG - [E3] [ET3] MFZ-KT35VG - [E3] [ET3] MFZ-KT50VG - [E3] [ET3] MFZ-KT60VG - [E3] [ET3]
1-10. INDOOR UNIT STRUCTURAL PARTS, HEAT EXCHANGER AND FUNCTIONAL PARTS

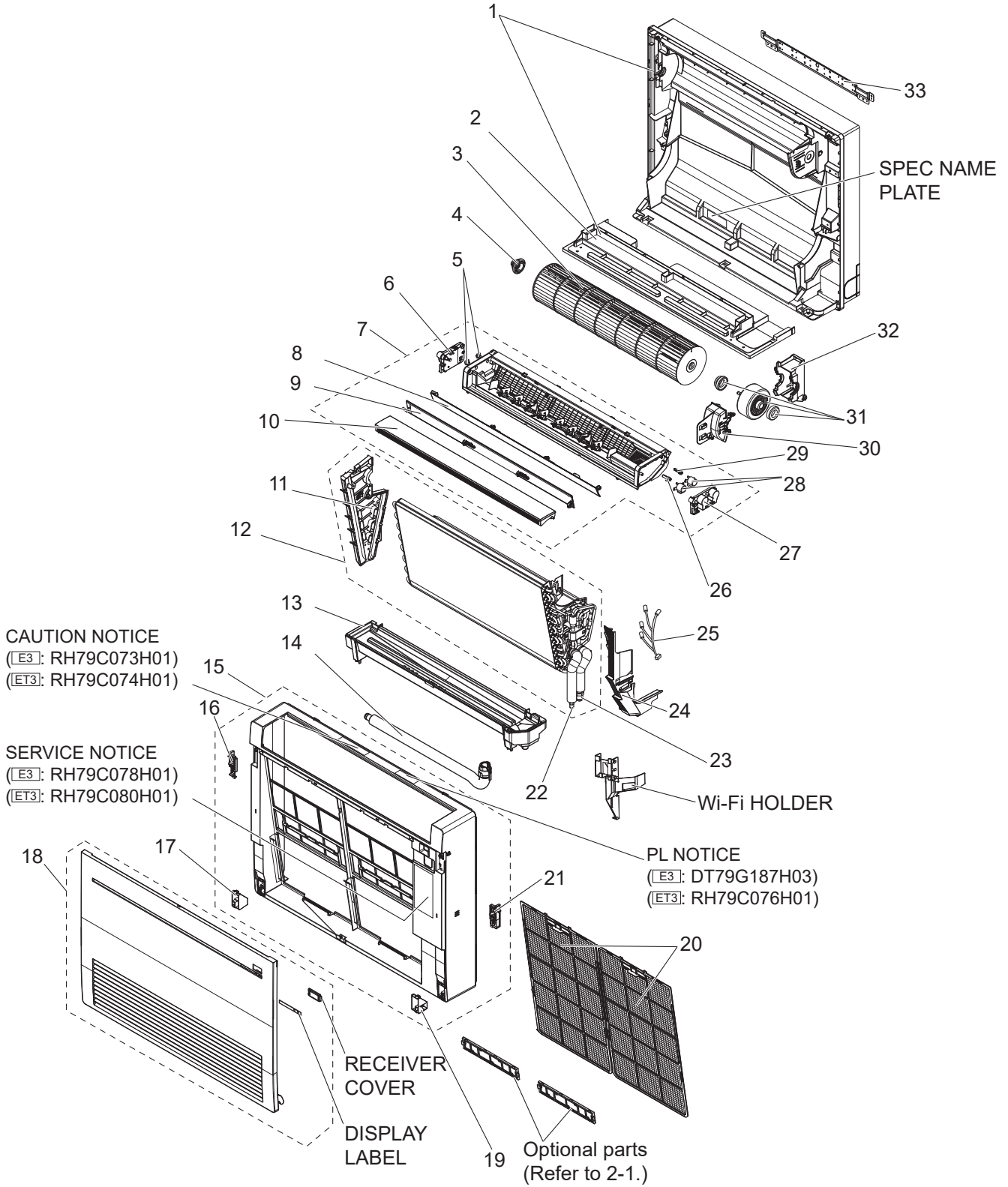

1-10. INDOOR UNIT STRUCTURAL PARTS, HEAT EXCHANGER AND FUNCTIONAL PARTS

- The part quantity below indicates the required number of pieces per unit.
- The circled No. indicates that the part is not shown in the figure.

No.	Part No.	Part Name	MFZ-KT25VG - [E3]	MFZ-KT25VG - [ET3]	MFZ-KT35VG - [E3]	MFZ-KT35VG - [ET3]	MFZ-KT50VG - [E3]	MFZ-KT50VG - [ET3]	MFZ-KT60VG - [E3]	MFZ-KT60VG - [ET3]	Symbol in Wiring Diagram	Remarks [Drawing No.]
1	M21 EBJ 234	BOX ASSEMBLY	1		1		1		1			Includes base without spec name plate
1	M21 EBK 234	BOX ASSEMBLY		1		1		1		1		Includes base without spec name plate [SQ25A544G07]
2	—	BASE	1	1	1	1	1	1	1	1		
3	M21 EAA 302	LINE FLOW FAN ASSEMBLY	1	1	1	1	1	1	1	1		
4	M21 EA3 509	BEARING ASSEMBLY	1	1	1	1	1	1	1	1		
5	M21 EA5 071	VANE SLEEVE	2	2	2	2	2	2	2	2		
6	M21 EA4 306	MULTI-FLOW VANE MOTOR UNIT	1	1	1	1	1	1	1	1	MV3	
7	M21 EAY 235	NOZZLE ASSEMBLY	1	1	1	1	1	1	1	1		
8	M21 EAA 040	VERTICAL VANE	1	1	1	1	1	1	1	1		
9	M21 EA9 040	HORIZONTAL VANE	1	1	1	1	1	1	1	1		
10	M21 EA8 040	MULTI-FLOW VANE	1	1	1	1	1	1	1	1		
11	—	HAIRPIN HOLDER ASSEMBLY	1	1	1	1	1	1	1	1		[DQ00T279G05]
12	M21 EJP 620	INDOOR HEAT EXCHANGER	1	1	1	1						
12	M21 EJR 620	INDOOR HEAT EXCHANGER					1	1				
12	M21 EJS 620	INDOOR HEAT EXCHANGER							1	1		
13	M21 EA5 700	DRAIN PAN ASSEMBLY	1	1	1	1	1	1	1	1		
14	M21 7K1 703	DRAIN HOSE ASSEMBLY	1	1	1	1	1	1	1	1		
15	T2W EC2 000	PANEL ASSEMBLY	1		1		1		1			Includes notice
15	T2W EC4 000	PANEL ASSEMBLY		1		1		1		1		Includes notice
16	M21 EA0 099	HOOK (LEFT) ASSEMBLY	1	1	1	1	1	1	1	1		
17	M21 EA8 039	ARM HOLDER (LEFT)	1	1	1	1	1	1	1	1		
18	M21 EBR 010	FRONT PANEL	1	1	1	1	1	1	1	1		Includes receiver cover and display label
19	M21 EA9 039	ARM HOLDER (RIGHT)	1	1	1	1	1	1	1	1		
20	M21 EAS 100	AIR PURIFYING FILTER	2	2	2	2	2	2	2	2		
21	M21 EA1 099	HOOK (RIGHT) ASSEMBLY	1	1	1	1	1	1	1	1		
22	M21 L3V 664	UNION (LIQ)	1	1	1	1	1	1	1	1		ø6.35
23	M21 L3V 663	UNION (GAS)	1	1	1	1						ø9.52
23	M21 L5V 663	UNION (GAS)					1	1	1	1		ø12.7
24	—	WATER COVER	1	1	1	1	1	1	1	1		[DQ00T288G04]
25	M21 EBF 305	INDOOR COIL THERMISTOR	1	1	1	1	1	1			RT12, RT13	
25	M21 EA9 305	INDOOR COIL THERMISTOR							1	1	RT12, RT13, RT14, RT15	
26	M21 EA5 049	HORIZONTAL VANE MOTOR SHAFT	1	1	1	1	1	1	1	1		
27	M21 EA1 506	VANE MOTOR SUPPORT	1	1	1	1	1	1	1	1		
28	M21 EA5 306	VANE MOTOR	2	2	2	2	2	2	2	2	MV1, MV2	
29	M21 EA6 049	VERTICAL VANE MOTOR SHAFT	1	1	1	1	1	1	1	1		
30	M21 EA3 023	MOTOR BAND	1	1	1	1	1	1	1	1		
31	T2W EFE 300	INDOOR FAN MOTOR ASSEMBLY	1	1	1	1					MF	RC0J30-□□
31	M21 EAM 300	INDOOR FAN MOTOR ASSEMBLY					1	1	1	1	MF	RC0J40-□□
32	M21 EA3 791	MOTOR BED	1	1	1	1	1	1	1	1		
33	T2W L3V 233	BACK PLATE	1	1	1	1	1	1	1	1		
③④	T2W EA1 938	JOINT PIPE							1	1		
③⑤	—	LEAD WIRE ASSEMBLY	1	1	1	1	1	1	1	1		[DY00C344G04] To terminal block
③⑥	—	LEAD WIRE ASSEMBLY	1	1	1	1	1	1	1	1		[DY00C346G03] To vane motor
③⑦	—	LEAD WIRE ASSEMBLY	1	1	1	1	1	1	1	1		[DY00C345G03] To display receiver P.C. board
③⑧	—	LEAD WIRE ASSEMBLY	1	1	1	1	1	1	1	1		[RH78C059G01] To R32 sensor

MFZ-KT25VG - [E3] [ET3] MFZ-KT35VG - [E3] [ET3] MFZ-KT50VG - [E3] [ET3] MFZ-KT60VG - [E3] [ET3]
1-11. INDOOR UNIT ELECTRICAL PARTS

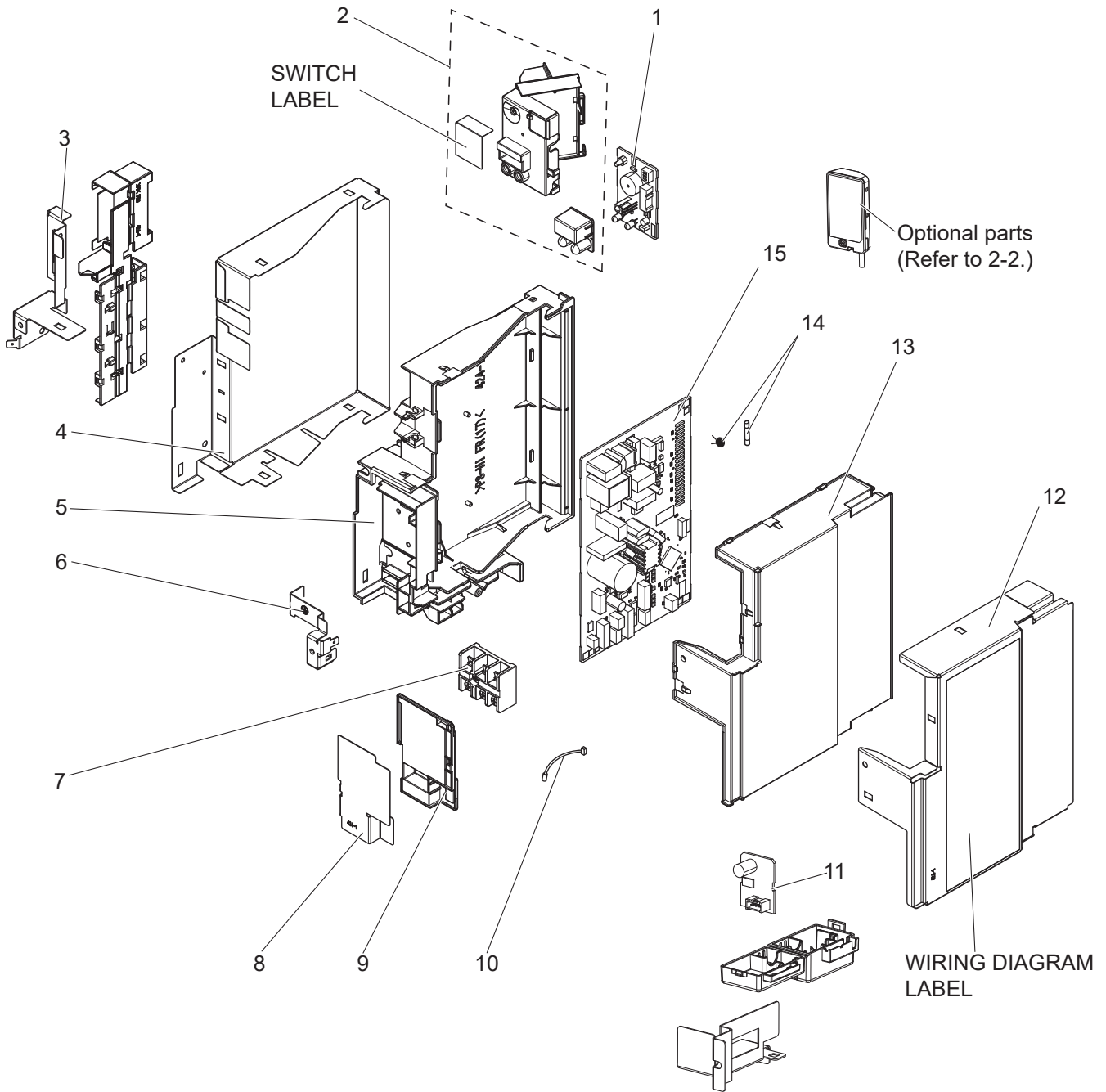

1-12. ACCESSORY AND REMOTE CONTROLLER

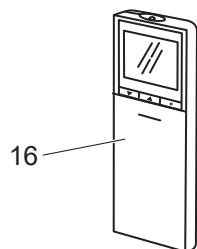

1-11. INDOOR UNIT ELECTRICAL PARTS

1. The part quantity below indicates the required number of pieces per unit.

No.	Part No.	Part Name	MFZ-KT25VG - [E3]	MFZ-KT25VG - [ET3]	MFZ-KT35VG - [E3]	MFZ-KT35VG - [ET3]	MFZ-KT50VG - [E3]	MFZ-KT50VG - [ET3]	MFZ-KT60VG - [E3]	MFZ-KT60VG - [ET3]	Symbol in Wiring Diagram	Remarks [Drawing No.]
1	T2W EBE 328	DISPLAY RECEIVER P.C. BOARD ASSEMBLY	1	1	1	1	1	1	1	1		
2	T2W EAJ 012	SWITCH HOLDER SET	1	1	1	1	1	1	1	1		Includes switch label
3	—	TB COVER	1	1	1	1	1	1	1	1		[DY02B654G01]
4	—	PB COVER LEFT	1	1	1	1	1	1	1	1		[DY02A632G03]
5	—	PB BOX	1	1	1	1	1	1	1	1		[DY25A631G06]
6	—	EARTH PLATE	1	1	1	1	1	1	1	1		[DY02B655G02]
7	M21 EA3 376	TERMINAL BLOCK	1	1	1	1	1	1	1	1	TB	
8	—	VA CLAMP COVER	1	1	1	1	1	1	1	1		[DK02B679G02]
9	—	VA CLAMP	1	1	1	1	1	1	1	1		[DK25B680G03]
10	M21 EAA 305	ROOM TEMPERATURE THERMISTOR	1	1	1	1	1	1	1	1	RT11	
11	M21 EA2 334	R32 SENSOR	1	1	1	1	1	1	1	1		
12	—	PB COVER RIGHT	1	1	1	1	1	1	1	1		[DK02A696G01] Without wiring diagram label
13	—	PB COVER	1	1	1	1	1	1	1	1		[DK25A695G01]
14	M21 EA5 313	FUSE VARISTOR SET	1	1	1	1	1	1	1	1	F11/NR11	T3.15AL250V
15	T2W FEA 450	ELECTRONIC CONTROL P.C. BOARD	1	1								
15	T2W FEC 450	ELECTRONIC CONTROL P.C. BOARD			1	1						
15	T2W FED 450	ELECTRONIC CONTROL P.C. BOARD					1	1				
15	T2W FEE 450	ELECTRONIC CONTROL P.C. BOARD							1	1		

1-12. ACCESSORY AND REMOTE CONTROLLER

1. The part quantity below indicates the required number of pieces per unit.

No.	Part No.	Part Name	MFZ-KT25VG - [E3]	MFZ-KT25VG - [ET3]	MFZ-KT35VG - [E3]	MFZ-KT35VG - [ET3]	MFZ-KT50VG - [E3]	MFZ-KT50VG - [ET3]	MFZ-KT60VG - [E3]	MFZ-KT60VG - [ET3]	Symbol in Wiring Diagram	Remarks
16	T2W EHJ 426	REMOTE CONTROLLER ASSEMBLY	1	1	1	1	1	1	1	1		SH24G

MFZ-KT25VGK - [E1] [ET1] MFZ-KT35VGK - [E1] [ET1] MFZ-KT50VGK - [E1] [ET1] MFZ-KT60VGK - [E1] [ET1]
1-13. INDOOR UNIT STRUCTURAL PARTS, HEAT EXCHANGER AND FUNCTIONAL PARTS

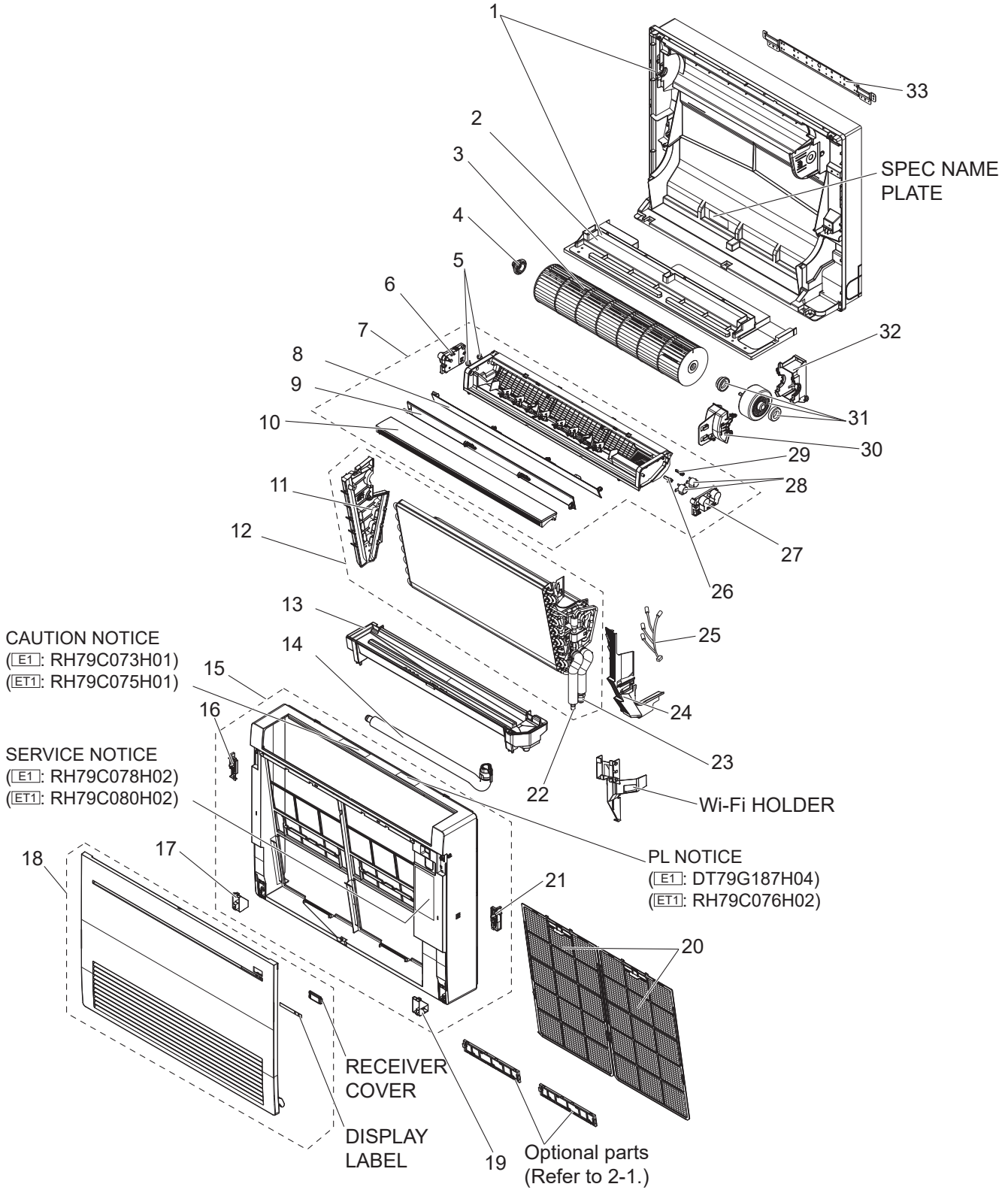

1-13. INDOOR UNIT STRUCTURAL PARTS, HEAT EXCHANGER AND FUNCTIONAL PARTS

- The part quantity below indicates the required number of pieces per unit.
- The circled No. indicates that the part is not shown in the figure.

No.	Part No.	Part Name	MFZ-KT25VGK - [E1]	MFZ-KT25VGK - [ET1]	MFZ-KT35VGK - [E1]	MFZ-KT35VGK - [ET1]	MFZ-KT50VGK - [E1]	MFZ-KT50VGK - [ET1]	MFZ-KT60VGK - [E1]	MFZ-KT60VGK - [ET1]	Symbol in Wiring Diagram	Remarks [Drawing No.]
1	M21 ECA 234	BOX ASSEMBLY	1		1		1		1			Includes base without spec name plate
1	M21 ECC 234	BOX ASSEMBLY		1		1		1		1		Includes base without spec name plate [SQ25A544G07]
2	—	BASE	1	1	1	1	1	1	1	1		
3	M21 EAA 302	LINE FLOW FAN ASSEMBLY	1	1	1	1	1	1	1	1		
4	M21 9G8 509	BEARING ASSEMBLY	1	1	1	1	1	1	1	1		
5	M21 EA5 071	VANE SLEEVE	2	2	2	2	2	2	2	2		
6	M21 EA4 306	MULTI-FLOW VANE MOTOR UNIT	1	1	1	1	1	1	1	1	MV3	
7	M21 EAY 235	NOZZLE ASSEMBLY	1	1	1	1	1	1	1	1		
8	M21 EAA 040	VERTICAL VANE	1	1	1	1	1	1	1	1		
9	M21 EA9 040	HORIZONTAL VANE	1	1	1	1	1	1	1	1		
10	M21 EA8 040	MULTI-FLOW VANE	1	1	1	1	1	1	1	1		
11	—	HAIRPIN HOLDER ASSEMBLY	1	1	1	1	1	1	1	1		[DQ00T279G05]
12	M21 EJP 620	INDOOR HEAT EXCHANGER	1	1	1	1						
12	M21 EJR 620	INDOOR HEAT EXCHANGER					1	1				
12	M21 EJS 620	INDOOR HEAT EXCHANGER							1	1		
13	M21 EA5 700	DRAIN PAN ASSEMBLY	1	1	1	1	1	1	1	1		
14	M21 7K1 703	DRAIN HOSE ASSEMBLY	1	1	1	1	1	1	1	1		
15	T2W ED5 000	PANEL ASSEMBLY	1		1		1		1			Includes notice
15	T2W ED6 000	PANEL ASSEMBLY		1		1		1		1		Includes notice
16	M21 EA0 099	HOOK (LEFT) ASSEMBLY	1	1	1	1	1	1	1	1		
17	M21 EA8 039	ARM HOLDER (LEFT)	1	1	1	1	1	1	1	1		
18	T2W EDS 010	FRONT PANEL	1	1	1	1	1	1	1	1		Includes receiver cover and display label
19	M21 EA9 039	ARM HOLDER (RIGHT)	1	1	1	1	1	1	1	1		
20	M21 EAS 100	AIR PURIFYING FILTER	2	2	2	2	2	2	2	2		
21	M21 EA1 099	HOOK (RIGHT) ASSEMBLY	1	1	1	1	1	1	1	1		
22	M21 L3V 664	UNION (LIQ)	1	1	1	1	1	1	1	1		ø6.35
23	M21 L3V 663	UNION (GAS)	1	1	1	1						ø9.52
23	M21 L5V 663	UNION (GAS)					1	1	1	1		ø12.7
24	—	WATER COVER	1	1	1	1	1	1	1	1		[DQ00T288G04]
25	T2W EDY 305	INDOOR COIL THERMISTOR	1	1	1	1	1	1			RT12, RT13	
25	T2W EDW 305	INDOOR COIL THERMISTOR							1	1	RT12, RT13, RT14, RT15	
26	M21 EA5 049	HORIZONTAL VANE MOTOR SHAFT	1	1	1	1	1	1	1	1		
27	M21 EA1 506	VANE MOTOR SUPPORT	1	1	1	1	1	1	1	1		
28	M21 EA5 306	VANE MOTOR	2	2	2	2	2	2	2	2	MV1, MV2	
29	M21 EA6 049	VERTICAL VANE MOTOR SHAFT	1	1	1	1	1	1	1	1		
30	M21 EA3 023	MOTOR BAND	1	1	1	1	1	1	1	1		
31	T2W EFE 300	INDOOR FAN MOTOR ASSEMBLY	1	1	1	1					MF	RC0J30-□□
31	T2W EFL 300	INDOOR FAN MOTOR ASSEMBLY					1	1	1	1	MF	RC0J40-□□
32	M21 EA3 791	MOTOR BED	1	1	1	1	1	1	1	1		
33	T2W L3V 233	BACK PLATE	1	1	1	1	1	1	1	1		
③④	T2W EA1 938	JOINT PIPE							1	1		
③⑤	—	LEAD WIRE ASSEMBLY	1	1	1	1	1	1	1	1		[SM78L302G01] To terminal block
③⑥	—	LEAD WIRE ASSEMBLY	1	1	1	1	1	1	1	1		[SM78L300G01] To vane motor
③⑦	—	LEAD WIRE ASSEMBLY	1	1	1	1	1	1	1	1		[SM78L301G01] To display receiver P.C. board
③⑧	—	LEAD WIRE ASSEMBLY	1	1	1	1	1	1	1	1		[RH78C059G01] To R32 sensor

MFZ-KT25VGK - [E1] [ET1] MFZ-KT35VGK - [E1] [ET1] MFZ-KT50VGK - [E1] [ET1] MFZ-KT60VGK - [E1] [ET1]
1-14. INDOOR UNIT ELECTRICAL PARTS

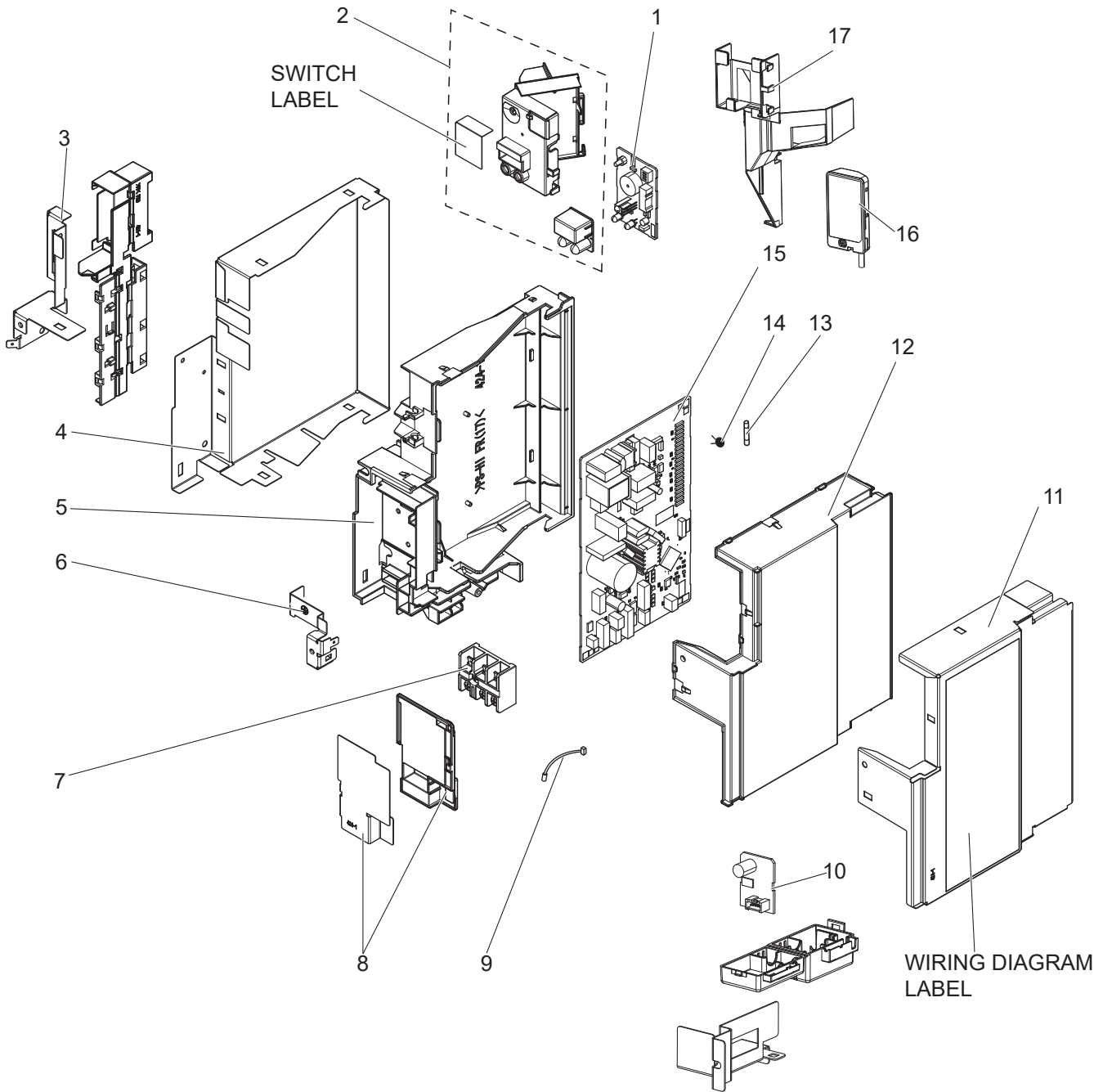

1-15. ACCESSORY AND REMOTE CONTROLLER

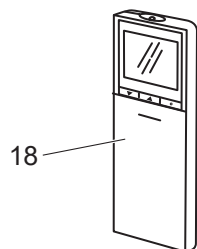

1-14. INDOOR UNIT ELECTRICAL PARTS

1. The part quantity below indicates the required number of pieces per unit.

No.	Part No.	Part Name	MFZ-KT25VGK - [E1]	MFZ-KT25VGK - [ET1]	MFZ-KT35VGK - [E1]	MFZ-KT35VGK - [ET1]	MFZ-KT50VGK - [E1]	MFZ-KT50VGK - [ET1]	MFZ-KT60VGK - [E1]	MFZ-KT60VGK - [ET1]	Symbol in Wiring Diagram	Remarks [Drawing No.]
1	T2W EBT 328	DISPLAY RECEIVER P.C. BOARD ASSEMBLY	1	1	1	1	1	1	1	1		
2	T2W EAW 012	SWITCH HOLDER SET	1	1	1	1	1	1	1	1		Includes switch label
3	—	TB COVER	1	1	1	1	1	1	1	1		[DY02B654G01]
4	—	PB COVER LEFT	1	1	1	1	1	1	1	1		[DY02A632G03]
5	—	PB BOX	1	1	1	1	1	1	1	1		[DY25A631G06]
6	—	EARTH PLATE	1	1	1	1	1	1	1	1		[DY02B655G02]
7	M21 EA3 376	TERMINAL BLOCK	1	1	1	1	1	1	1	1	TB	
8	—	VA CLAMP ASSEMBLY	1	1	1	1	1	1	1	1		[DK00G051G03]
9	M21 EAA 305	ROOM TEMPERATURE THERMISTOR	1	1	1	1	1	1	1	1	RT11	
10	M21 EA2 334	R32 SENSOR	1	1	1	1	1	1	1	1		
11	—	PB COVER RIGHT	1	1	1	1	1	1	1	1		[DK02A696G01] Without wiring diagram label
12	—	PB COVER	1	1	1	1	1	1	1	1		[DK25A695G01]
13	M21 EA2 381	FUSE	1	1	1	1	1	1	1	1	F11	T6.3AL 250V
14	M21 9K1 313	VARISTOR	1	1	1	1	1	1	1	1	NR11	S10K300E2G10AS3K1
15	T2W HCS 450	ELECTRONIC CONTROL P.C. BOARD	1	1								
15	T2W HCT 450	ELECTRONIC CONTROL P.C. BOARD			1	1						
15	T2W HCW 450	ELECTRONIC CONTROL P.C. BOARD					1	1				
15	T2W HCY 450	ELECTRONIC CONTROL P.C. BOARD							1	1		
16	T2W EAW 441	WIFI-INTERFACE	1	1	1	1	1	1	1	1		
17	—	WIFI HOLDER	1	1	1	1	1	1	1	1		[DK25Y639G03]

1-15. ACCESSORY AND REMOTE CONTROLLER

1. The part quantity below indicates the required number of pieces per unit.

No.	Part No.	Part Name	MFZ-KT25VGK - [E1]	MFZ-KT25VGK - [ET1]	MFZ-KT35VGK - [E1]	MFZ-KT35VGK - [ET1]	MFZ-KT50VGK - [E1]	MFZ-KT50VGK - [ET1]	MFZ-KT60VGK - [E1]	MFZ-KT60VGK - [ET1]	Symbol in Wiring Diagram	Remarks
18	T2W EJ7 426	REMOTE CONTROLLER ASSEMBLY	1	1	1	1	1	1	1	1		SH25P

2-1. AIR CLEANING FILTER

1. SILVER-IONIZED AIR PURIFIER FILTER

Model	Part No.
MFZ-KT25VG - [E1], [ET1], [ER1], [E2], [ET2], [E3], [ET3]	MAC-2370FT-E
MFZ-KT35VG - [E1], [ET1], [ER1], [E2], [ET2], [E3], [ET3]	
MFZ-KT50VG - [E1], [ET1], [ER1], [E2], [ET2], [E3], [ET3]	
MFZ-KT60VG - [E1], [ET1], [ER1], [E2], [ET2], [E3], [ET3]	
MFZ-KT25VGK - [E1], [ET1]	
MFZ-KT35VGK - [E1], [ET1]	
MFZ-KT50VGK - [E1], [ET1]	
MFZ-KT60VGK - [E1], [ET1]	

2. V BLOCKING FILTER

Model	Part No.
MFZ-KT25VG - [ER1], [E2], [ET2], [E3], [ET3]	MAC-2470FT-E
MFZ-KT35VG - [ER1], [E2], [ET2], [E3], [ET3]	
MFZ-KT50VG - [ER1], [E2], [ET2], [E3], [ET3]	
MFZ-KT60VG - [ER1], [E2], [ET2], [E3], [ET3]	
MFZ-KT25VGK - [E1], [ET1]	
MFZ-KT35VGK - [E1], [ET1]	
MFZ-KT50VGK - [E1], [ET1]	
MFZ-KT60VGK - [E1], [ET1]	

Every 3 months:

- Remove dirt by a vacuum cleaner.

When dirt cannot be removed by vacuum cleaning:

- Soak the filter and its frame in lukewarm water before rinsing it.
(Diluted mild detergents can be used when dirt cannot be removed.)
- After washing, dry it well in shade.

Every year:

- Replace it with a new air cleaning filter for best performance.

Replacement of the air cleaning filter

(1) Remove the front panel.

1. Push down the tab on the both sides of the unit to open the front panel.
2. Pull the front panel toward you to remove it.
3. Open the front panel completely and remove it.

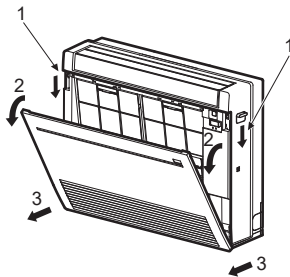

(3) Replace the air cleaning filter.

Fix the filter with the tabs securely.

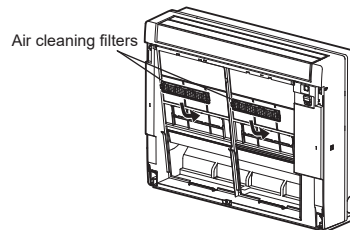

(2) Remove the air filter.

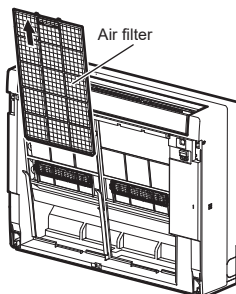

(4) Install the air filter.

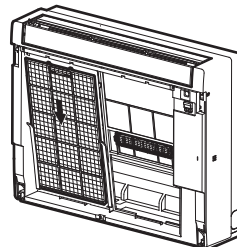

(5) Securely close the front panel.

Install the front panel by the removal procedure in reverse. Refer to (1) 1-3.

2-2. Wi-Fi INTERFACE

Model	Part No.
MFZ-KT25VG - [E3], [ET3]	MAC-587IF-E
MFZ-KT35VG - [E3], [ET3]	
MFZ-KT50VG - [E3], [ET3]	
MFZ-KT60VG - [E3], [ET3]	

How to install

When connecting the Wi-Fi interface (option) Install the interface in the holder as shown in the figure. Adjust the length of the cable, and bundle it as shown in the figure.

- (1) Remove the panel.
- (2) Open the cover of the indoor control P.C. board.
- (3) Joint the connecting cable to CN105 on the indoor control P.C. board.
- (4) Route the connecting cable through this point in the figure.
- (5) Attach the cable clamp provided with interface/connector cable to the thick part of the connecting cable with a screw 4 × 16 as shown in the figure.
- (6) Set the Wi-Fi interface in the holder.
- (7) Set the connecting cable in the holder, then fix it with the band (L).
- (8) Bundle the excess cable with the band (L). The rolled part should be about 140 mm.
- (9) Close the cover of the indoor control P.C. board. Be careful not to catch the thin part of the connecting cable in the cover. Reinstall the panel.

▲ WARNING

Fix the connecting cable at the prescribed position securely. Incorrect installation may cause electric shock, fire, and/or malfunction.

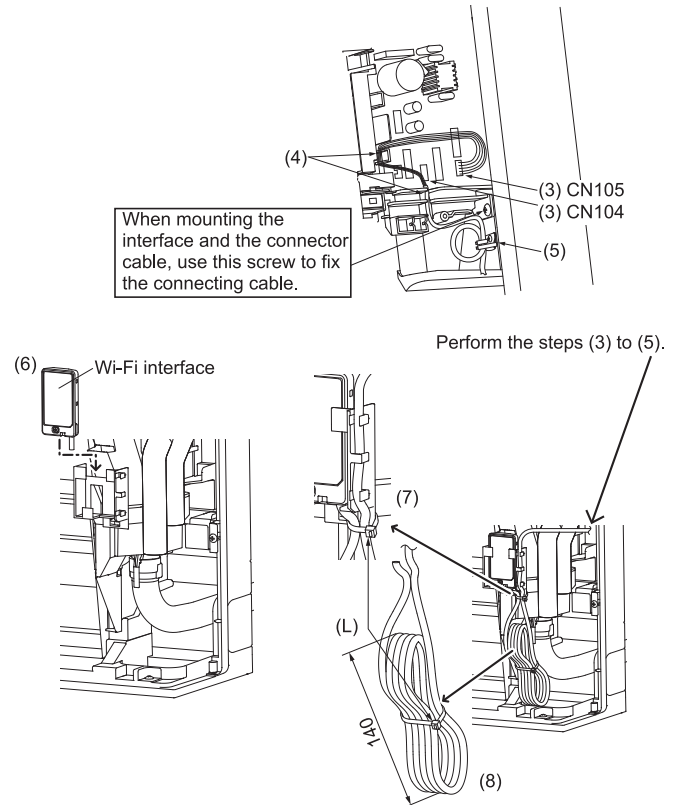

mitsubishi electric corporation

HEAD OFFICE: TOKYO BUILDING, 2-7-3, MARUNOUCHI, CHIYODA-KU, TOKYO 100-8310, JAPAN

© Copyright 2019 MITSUBISHI ELECTRIC CORPORATION

Issued: Nov. 2025. No. OBB843 REVISED EDITION-E

Issued: May 2024. No. OBB843 REVISED EDITION-D

Issued: Apr. 2024. No. OBB843 REVISED EDITION-C

Issued: Jul. 2021. No. OBB843 REVISED EDITION-B

Issued: Aug. 2019. No. OBB843 REVISED EDITION-A

Published: Jun. 2019. No. OBB843

Made in Japan

Specifications are subject to change without notice.