

Data Book



NX2-G06 0404 - 0928_202006_EN R454B
ELCA_Engine ver.4.4.2.0

NX2-G06 0404 - 0928

379-872 kW

Chiller, air source for outdoor installation



R R454B

SCROLL

T SHELL & TUBES



(The photo of the unit is indicative and may vary depending on the model)

- ✓ **LOW GWP REFRIGERANT**
- ✓ **ErP COMPLIANT 2021**
- ✓ **ALUMINIUM MICRO-CHANNEL HEAT EXCHANGERS**
- ✓ **INTEGRATED HYDRONIC MODULE**
- ✓ **EXTREMELY SILENT OPERATION**
- ✓ **HIGH EFFICIENCY**
- ✓ **WIDE OPERATING RANGE**
- ✓ **GROUP CONTROLS WITH DYNAMIC MASTER**
- ✓ **VARIABLE PRIMARY FLOW**

CERTIFICATIONS

Product certifications



Voluntary product certifications



Check ongoing validity of certificate:

www.eurovent-certification.com

or

www.certiflash.com

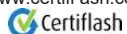

System certifications



MITSUBISHI ELECTRIC HYDRONICS & IT COOLING SYSTEMS S.p.A.

Quality System complying with the requirements of UNI EN ISO 9001:2008 regulation
Environmental Management System complying with the requirements of UNI EN ISO 14001:2004 regulation
Occupational Health and Safety Management System complying with the requirements of BS OHSAS 18001:2007

1.1	PRODUCT PRESENTATION	pg.1.1.1 / 1.1.3
2.1	INCIPIIT	pg.2.1.1 / 2.1.1
3.1	UNIT STANDARD COMPOSITION	pg.3.1.1 / 3.1.4
4.1	OPTIONS	pg.4.1.1 / 4.1.13
5.1	GENERAL TECHNICAL DATA	pg.5.1.1 / 5.1.6
6.1	TECHNICAL DATA SEASONAL EFFICIENCY IN COOLING (EN14825 VALUE)	pg.6.1.1 / 6.1.0
7.1	OPERATING LIMITS	pg.7.1.1 / 7.1.6
8.1	HYDRAULIC DATA	pg.8.1.1 / 8.1.2
9.1	ELECTRICAL DATA	pg.9.1.1 / 9.1.4
10.1	FULL LOAD SOUND LEVEL	pg.10.1.1 / 10.1.3
11.1	DIMENSIONAL DRAWINGS	pg.11.1.1 / 11.1.4
12.1	HYDRONIC GROUP	pg.12.1.1 / 12.1.23

Liability disclaimer

The present publication is drawn up by of information only and does not constitute an offer binding upon Mitsubishi Electric Hydronics & IT Cooling Systems S.p.A.

Mitsubishi Electric Hydronics & IT Cooling Systems S.p.A. has compiled the content of this publication to the best of its knowledge. The data contained herein are subject to change without notice. Mitsubishi Electric Hydronics & IT Cooling Systems S.p.A. explicitly rejects any liability for any direct or indirect damage, in the broadest sense, arising from or related to the use and/or interpretation of this publication. All content is copyrighted by Mitsubishi Electric Hydronics & IT Cooling Systems S.p.A.

The units highlighted in this publication contain R454B [GWP₁₀₀ 466] fluorinated greenhouse gases.

Functions



Cooling

Refrigerant



R454B

Compressors



Scroll compressor

Fan



Axial fan

Exchangers



Shell & Tubes

Other features



Eurovent



VPF

1.1 PRODUCT PRESENTATION

GREEN CERTIFICATION RELEVANT

Mitsubishi Electric Hydronics & IT Cooling Systems S.p.A., as a major player in the world HVAC market and a leading manufacturer of energy efficient, sustainable HVAC solutions, recognizes and supports the diffusion of green certification systems, as an effective way to deliver high performance buildings and improve the quality and the sustainability of the built environment.

Since the first certification system was introduced at the beginning of the 1990s, the demand for certified buildings has grown considerably, as well as the number of standards, rating and certification programs. Operating worldwide Mitsubishi Electric Hydronics & IT Cooling Systems S.p.A., has extensive experience with many of them and is active member of Green Building Council Italy.

Mitsubishi Electric Hydronics & IT Cooling Systems S.p.A., commitment to develop responsible and sustainable HVAC solutions, is reflected by a full range of premium efficiency products and systems, designed with special care to improve building energy performance ratings, according to major certification protocols, including LEED, BREEM, GREENSTAR, BCA, NABERS, DNGB, HQE and BEAM.

To find out more about how our products contribute to enhanced green certification rating and energy performance of a building, please refer to:

https://www.melcohit.com/EN/Environment/green_certifications/



PRODUCT PRESENTATION

Outdoor unit for the production of chilled water with hermetic rotary Scroll compressors, ozone-friendly refrigerant R454B, axial-flow fans, micro-channel full-aluminum condensing coils, single-pass shell and tubes evaporator designed and produced internally and electronic expansion valve. The range is composed by units equipped with four, five, six and eight compressors in multi-circuit configuration.

1.3 LOW GWP REFRIGERANT

The new generation refrigerant R454B is the most eco-sustainable alternative to traditional refrigerant R410A, offering a 76% reduction in terms of GWP (Global Warming Potential GWP of R454B = 467, GWP of R410A = 1924 as per IPCC rev. 5th) and zero impact on the ozone layer.

1.4 ErP COMPLIANT 2021

The units comply and exceed the minimum seasonal energy efficiency requirements that will start from 2021, imposed by the eco-sustainable design Directive 2009/125/EC. The seasonal efficiency can be further raised thanks to the optional EC fans.

1.5 ALUMINIUM MICRO-CHANNEL HEAT EXCHANGERS

The full aluminium micro-channel condenser coils deliver high efficiency whilst ensuring a reduced refrigerant volume and a lower unit weight. The e-coating protection (optional) grants the highest level of corrosion resistance in any condition, even in the most aggressive environments.

1.6 INTEGRATED HYDRONIC MODULE

The built-in hydronic module already contains the main water circuit components; it is available as option with single or twin in-line pump, for achieving low or high head, fixed or variable speed and buffer tank.

1.7 EXTREMELY SILENT OPERATION

The best compromise between silence and efficiency, as result of a systematic design oriented to minimize the noise level.

1.8 HIGH EFFICIENCY

Very high efficiency at full and partial loads, at the highest market levels, thanks to the adopted technological solutions. These units ensure low operating costs and therefore a quick payback time.

1.9 WIDE OPERATING RANGE

Full load operation is ensured with outdoor air temperature from -20°C up to 48°C (up to 52°C at partial load). Production of evaporator leaving water temperature from -12°C to 20°C.

1.10 GROUP CONTROLS WITH DYNAMIC MASTER

Load sharing, sequencing, active redundancy, priority of resource activation, alarm management, these are only some of the LAN functions that the unit is able to manage when connected to a group of chillers. Besides, the system's stability is ensured even in case of alarm or malfunctioning thanks to the Dynamic Master logic.

1.11 VARIABLE PRIMARY FLOW

Energy savings due to variable pump speed management based on load demand and the variable flow ensures the units also function in critical working conditions.

NX2-G06 / D / A / 0928

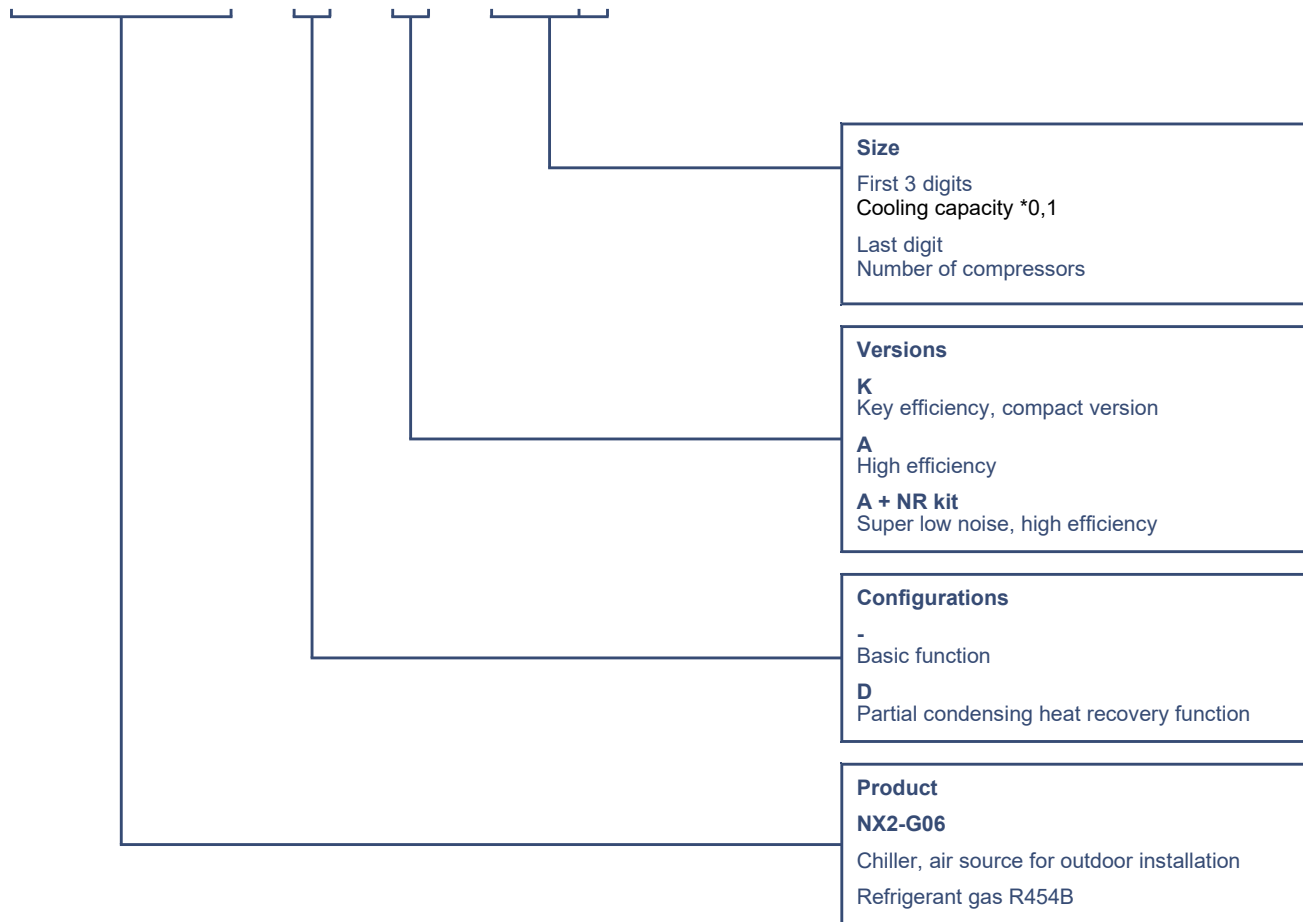

3.1 UNIT STANDARD COMPOSITION

CONFIGURATIONS

- , standard unit

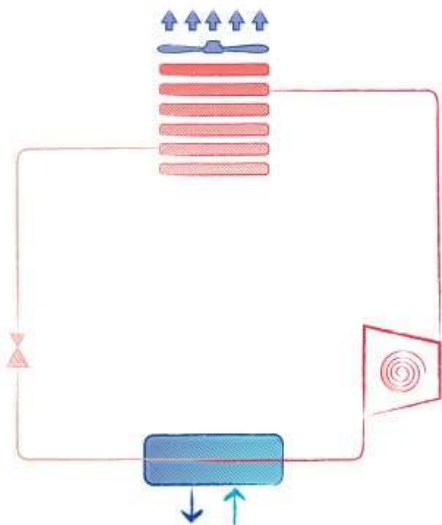

No heat recovery is possible.

/D, unit with partial heat recovery

Heat recovery: ON

Heat recovery: OFF (water flow stopped)

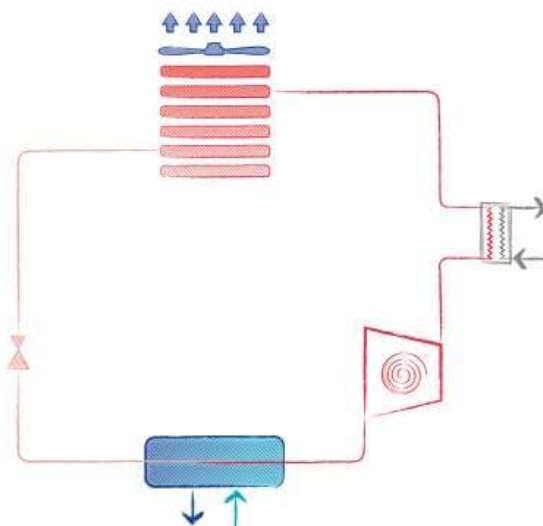
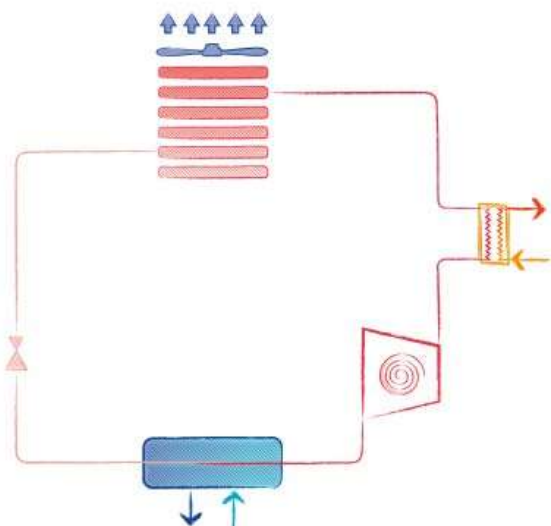

Each refrigerant circuit is fitted with a desuperheater.

The superheating heat recovery is only possible when the temperature of the hot water circuit is lower than the compressor discharge temperature. The heat recovery and its amount depends on the unit's operating conditions, in particular the outdoor air temperature and the load percentage. It is advised to interrupt the water flow to the desuperheater when the conditions for an actual heat recovery are not met.

The smart management of the desuperheater pump(s) is possible with the option 3371 D – RELAY 1 PUMP (ON/OFF), further information is available in the bulletin section dedicated to accessories.

Partial heat recovery operating limits:

	MIN temperature	MAX temperature
Inlet water	25°C (77°F)	56°C (132,8°F)
Outlet water	30°C (86°F)	60°C (140°F)

UNIT STANDARD COMPOSITION

3.2 Chiller, air source for outdoor installation

Outdoor unit for the production of chilled water with hermetic rotary Scroll compressors, ozone-friendly refrigerant R454B, axial-flow fans, micro-channel full-aluminum condensing coils, single-pass shell and tubes evaporator designed and produced internally and electronic expansion valve. The range is composed by units equipped with four, five, six and eight compressors in multi-circuit configuration.

- The unit is supplied fully refrigerant charged and factory tested. On site installation only requires power and hydraulic connection.

3.3 Structure

Structure specifically designed for outdoor installation. Base and frame in hot-galvanised steel sheet of suitable thickness. All parts polyester-powder painted to assure total weather resistance. Painting: RAL 7035 textured finish. The units are provided as standard with lateral panelling for covering the V-shaped coil modules.

3.4 Refrigerant circuit

Unit designed with 2, 3 or 4 separate and independent refrigerant circuits, with 2 or 3 compressors each. The units feature an internally designed, patent-pending device, able to optimize the thermodynamic cycle. In addition to the main components described in the following sections, each refrigerant circuit is fitted as standard with:

- drier filter with replaceable cartridge
- refrigerant line sight glass with humidity indicator
- safety switching device for limiting the pressure
- liquid line shut-off valve
- high and low pressure transducers
- electronic expansion valve
- liquid line solenoid valve
- high and low pressure safety valve
- visualization of the pressure's level directly from the controller's interface
- antifreeze electric heater for heat exchanger
- crankcase heater on each compressor

3.5 Compressor

Hermetic scroll compressors complete with an oil sump heater, electronic overheating protection with centralised manual reset and a two-pole electric motor.

3.6 R454B REFRIGERANT

The refrigerant used in these units is R454B, one of the most eco-sustainable refrigerants for replacing traditional R410A, thanks to the 76% lower GWP.

Unlike R410A, R454B is classified as A2L according to ISO 817. The first digit defines toxicity (A: NON-TOXIC), while the last digits define the flammability level (2L: MILDLY FLAMMABLE - low burning velocity). It is classified by PED Directive into Group 1.

The main characteristics of this refrigerant and some additional guidelines are reported below. Despite the minimal risk, the indications provided cannot replace a more detailed risk analysis if required, also based on any regulations in force in the installation area.

Further and more detailed guidelines are available in the dedicated area of the website www.melcohit.com (Guidelines) or in the dedicated addendum of the general installation and maintenance manual.

Main characteristics of R454B refrigerant:

- Safety classification (ASHRAE / ISO 817): A2L
- PED Group: 1
- Ozone Depletion Potential (ODP) (R11=1): 0
- AR5 (AR4) GWP (CO2=1): 467 (466)
- Composition (Wt %): 68,9% R32, 31,1% R1234yf
- LFL@23°C, 50% RH (% v/v): 11,7
- UFL@23°C, 50% RH (% v/v): 22,0
- Burning velocity (cm/s): 5,2
- Minimum Ignition Energy (mJ) (ASTM E582-13): 100-300

- All operations on the unit must be performed by trained and qualified personnel on flammable refrigerants handling, in accordance with the relevant local standards and codes of practice.

- The refrigerant is heavier than air and can stagnate, reaching a dangerous concentration. To avoid risks, maintain a safe environment by ensuring adequate ventilation.

- The units must be installed in such a way as to prevent any refrigerant leaks from flowing into the buildings or any place where it could cause damage to people, animals or properties. Pay particular attention to the presence and disposition of any external air intakes, doors, shutters, etc.
- The units are equipped with conveyed safety valves with external discharge. In case of over-pressure, refrigerant gas can escape from these valves: the discharge of these ducts must be directed towards safe areas and away from the ground or potential sources of ignition.

- Do not braze pipes and components containing refrigerant.
- Do not use flames to cut / open pipes.
- The units are equipped with a safety valve (water side). In case of breakage of the heat exchanger and resulting overpressure, refrigerant gas can escape from these valves: the discharge of these valves must be directed towards safe areas and away from the ground or potential sources of ignition.
- The hydraulic circuit must be designed in such a way as to prevent the release of refrigerant gas inside the buildings or in any case in places where it can cause damage to people, animals or properties.

3.7 Plant side heat exchanger

Direct expansion multi-circuit shell and tube exchanger with asymmetric side coolant flows for maintaining the coolant at the correct speed inside the tubes when passing from the liquid to the gas phase. The shell & tube is manufactured using copper tubes with internal grooves for favouring heat exchange and mechanically expanded onto the tube plates. The heat exchanger may be inspected to facilitate cleaning operations when using particularly hard water (limestone). The heat exchanger is lined on the outside with 9 mm thick closed-cell neoprene lagging to prevent condensation, with a thermal conductivity of 0,33 W/mK at 0°C. The heat exchanger is fitted with a differential pressure switch to monitor the correct flow of water when the unit is operating, thus preventing ice form forming inside. An electric antifreeze heater prevents the ice from forming inside the exchanger when the unit is not working but connected to the electrical supply. The heat exchanger is provided with a safety pressure release valve (water side) (10 bar).

3.8 Source side heat exchanger

Microchannel coils ideally positioned on a "V" block structure to optimize airflow and heat transfer. Made entirely in aluminum, the coils are not subjected to galvanic corrosion.

Fins and manifolds are made of aluminum AA3003 while the channels are made of a new aluminum alloy so defined Long Life Alloy (LLA). LLA alloy has a very fine grain microstructure that guarantees higher mechanical properties and a higher resistance to the inter-granular corrosion.

Channel small section favor refrigerant fluid turbulence, which enhances the heat exchange. Tube geometry maximize the surface touched by the air, thus allowing compact dimension and refrigerant charge reduction.

3.9 Features of the optional silenced units

Units with optional "acoustical enclosure" feature:

- Compressor enclosure with soundproofing insulation in polyester fiber mat (thickness of 30 mm on sides and on top, 15 mm on bottom)
- If the hydronic is present, the pump enclosure is acoustically insulated: 15 mm thick Fiberform (polyester fibres)

Units with optional "NR kit" (Noise Reducer kit) feature:

- Reduced fan speed (680 rpm)
- Compressor enclosure with soundproofing insulation in polyester fiber mat (thickness of 30 mm on sides and on top, 15 mm on bottom)
- If the hydronic is present, the pump enclosure is acoustically insulated: 15 mm thick Fiberform (polyester fibres)

3.10 Electrical and control panel

Electrical and control panel built to EN60204-1 and EC204-1 standards, complete with:

- Electronic control W3000+
- power circuit with electric bus bar distribution system
- fuses and contactors for compressors and fans
- auxiliary 4-20mA analogue input
- terminals for cumulative alarm block
- remote ON/OFF terminals
- general door lock isolator
- outdoor air temperature probe
- control circuit transformer
- spring-type control circuit terminal board
- Pump control relay + 0-10V modulating signal to control an external variable speed pump with the VPF.E control logic (plant-side constant ΔT for plants with primary circuit only and terminals with bypass)

3.11 Fan section source side

Axial electric fans, 800 mm diameter, protected to IP 54 and with insulation class 'F', featuring an external rotor and profiled blades.

Housed in an aerodynamic hood complete with safety guard. The fan + outlet set satisfies the efficiency requirements provided for by EcoDesign directive 327/11. 6-pole electric motor with built-in thermal protection. Condensation control with continuous adjustment of the fan speed with single fractioning (DVVF with phase-cut device). Rotational speed: 900 rpm for /K and /A versions, 680 rpm for versions with optional NR kit.

- EC fans (available as option): Axial electronically commutated fans (EC

UNIT STANDARD COMPOSITION

- fans), with external rotor, profiled die-cast aluminium blades, housed in aerodynamic hoods complete with guard grille. 6-poles electric motor with built-in thermal protection. The brushless motor, governed by a special controller, continuously adjust fans' speed to minimize energy consumption, electromagnetic noises and current's absorption even during start-up phase.

3.12 Certification and applicable directives

The unit complies with the following directives and relative amendments:

- CE Declaration of conformity certificate for the European Union
- 2014/35/EC Low Voltage Directive
- 2014/30/EC EMC Directive
- ErP Directive 2009/125/EC
- Machinery Directive 2006/42/EC
- PED Directive 2014/68/EC
- EAC Product quality certificate for Russian Federation
- ISO 14001 Company's Environmental Management System certification
- ISO 9001 Company's Quality Management System certification

3.13 Tests

Tests performed throughout the production process, as indicated in ISO9001.

Performance or noise tests can be performed by highly qualified staff in the presence of customers.

Performance tests comprise the measurement of:

- electrical data
- water flow rates
- working temperatures
- power input
- power output
- pressure drops on the water-side exchanger both at full load (at the conditions of selection and at the most critical conditions for the condenser) and at part load conditions.

During performance testing it is also possible to simulate the main alarm states.

Noise tests are performed to check noise emissions according to ISO9614.

3.14 Electronic control W3000+

W3000+ features an easy-to-use interface and a complete LCD display that allows one to consult and intervene by means of a multi-language menu (19 languages are available). The diagnostics includes a complete alarm management, with the "black-box" and the alarm history display for enhanced analysis of the unit operation. The programmable timer manages a weekly schedule organized into time bands to optimize unit performance by minimizing power consumption during periods of inactivity. Up to 10 daily time bands can be associated with different operating set points. As option, KIPLink is available - Keyboard In Your Pocket. KIPLink is the innovative user interface based on WiFi technology that allows one to operate on the unit directly from the smartphone or tablet.

The regulation is based on the patented "Quickmind" water temperature regulation logic uses self-adapting control to maintain flow temperatures and optimize performance even in low water content scenarios. As an alternative, the proportional or proportional-integral regulations are also available.

Optional proprietary devices can perform the adjustment of resources in systems made of several units. Consumption metering and performance measurement are possible as well. The variable primary flow control is always available as per standard (VPF.E function).

Supervision can be easily developed via proprietary devices or the integration in third party systems by means of the most common protocols as ModBus, Echelon, Bacnet-over-IP, Bacnet MS/TP RS485, Konnex, ModBus TCP/IP, SNMP. Compatibility with the remote keyboard (up to 8 units).



3.14 KIPLink - Keyboard In your Pocket (option 6196)

KIPLink - Keyboard In Your Pocket - is the innovative user interface based on WiFi technology that allows one to operate on the unit directly from the smartphone or tablet. Using KIPLink, it is possible to turn the unit on and off, adjust the set-point, plot the main operating variables, monitor in detail the status of the refrigerant circuits, the compressors, the fans (if present) and the pumps (if present) and display and reset the possible alarms.



3.14 Night mode (option 1430)

The night mode function allows to reduce the sound power of the unit, reducing the speed of the fans and the number of active compressors.

3.14 U.L.C. - User limit control (option 4960)

Guaranteed the start-up of the units with the option U.L.C. even when the critical working condition could generate an alarm.

The controller can manage a 3way mixing valve (not provided) by 0-10V signal for ensuring a dynamic control of the water temperature on user heat exchanger according to the operating limits allowed. This ensures the start-up and correct functioning of the unit into the envelope, also even critical whether condition.

3.14 LAN Multi Manager

Up to 8 units (chillers or free-cooling chillers, with the same firmware version) can communicate via serial connection.

All the group functions are implemented with master/slave logic, with dynamic master.

Hereunder is a brief description of the main group functions, further details are available in the dedicated user manual.

- Load management

There are two possible load management logics: load sharing and sequencing.

- Load sharing: the load is distributed equally among the active units of

UNIT STANDARD COMPOSITION

the group.

- Sequencing: the units are activated one after the other. When the first unit is saturated (all the available resources are used), the second unit is activated, and so forth until the load is fully covered.

- Dynamic master

In case of disconnection of the master unit, a new master is automatically elected among the other units, and the group functions remain active. The dynamic master function grants a backup solution to the net, overcoming the single point of failure typical of the static master architecture. Besides, it is possible to set the "master succession priority": in case of the master unit disconnection, the new master is elected among the units set as priority.

- Stand-by unit management

It is possible to set the number of units that remain in stand-by, the load will be managed (with load sharing or sequencing) among the other units of the group. The stand-by unit rotation is automatic, according to the running hours equalization. A stand-by unit is immediately activated in case of total failure or disconnection of one of the active units of the group, or in case the water temperature exceeds the safety threshold.

- Restart in sequence

After a power black-out, this group function coordinates the compressor activation time of the different units and prevents from dangerous current peaks due to simultaneous start-ups. Besides, it is possible to set the activation sequence of the units.

- Resource priority management

To make the most of the available cooling resources, it is possible to set the usage priority of each unit. The load management function will be adjusted accordingly. When available, the free-cooling is always given priority and is fully exploited before activating any compressor. Then the activation of the compressors follows the priority level assigned to the units.

- Auxiliary input

The auxiliary inputs are applied at a group level:

- 4-20 mA: remote set-point adjustments (analog input).

- Double set-point: remote switch between 2 set-points (digital input).

- Demand limit: remote signal to limit the unit's activable resources (digital input).

3.15 Versions

/K - Key efficiency

Key efficiency units grant the best cooling capacity/footprint ratio.

/A - High efficiency

High efficiency units with minimum investment payback time. High performing heat exchangers and generous heat exchanger surfaces.

3.16 Configurations

/D, unit with partial heat recovery

Unit for the production of chilled water, equipped with an auxiliary heat exchanger (desuperheater) on the compressor discharge for superheat recovery. The recovered heat is approximately the 20% of the total cooling capacity and can be used for domestic hot water production or other secondary uses, such as the integration of an existing boiler.

4.1 OPTIONS

OPTIONS	DESCRIPTIONS	BENEFITS	AVAILABLE FOR MODELS
2280 KIT ALLESTIMENTO :			
2282 NR kit	The option includes the fan speed reduction and the compressors' acoustical enclosure	The dedicated fans' speed calibration together with the soundproofing of the most critical components permit a significant noise reduction.	ALL
1020 REGULATIONS			
1015 HEAT EXCHANGERS NSW CERTIFIED	Heat exchangers with SafeWork NSW certificate		ALL
1440 USER INTERFACE			
1441 KIPLink + COMPACT KEYBOARD	In addition to KIPLink, the innovative user interface based on WiFi technology, the unit is equipped with the Compact keyboard with LCD display and buttons.		ALL
1442 KIPLink +7 INCH TOUCH SCREEN	In addition to KIPLink, the innovative user interface based on WiFi technology, the unit is equipped with the Touch interface, with a 7" WVGA colour display and a front USB port (WARNING: with outdoor temperature below 0°C the display response time may visibly increase).		ALL
6195 7 INCH TOUCH SCREEN	The unit is equipped with the Touch interface, with a 7" WVGA colour display and a front USB port (WARNING: with outdoor temperature below 0°C the display response time may visibly increase).	The touch-screen's technology is characterized by an easy-to-access data, and it allows an effective graphical representation of the main figures protecting the access through 3 privilege levels.	ALL
6196 KIPLink	The unit is equipped with KIPLink, the innovative user interface based on WiFi technology		ALL
6310 VISUAL DISPLAY PROTECTION			
6311 WITH DISPLAY PROTECTION	Display protection sealed panel	Provide complete protection against UV rays, atmospheric agents, sand storms.	ALL
380 NUMBERED WIRING			
381 NUMBERED WIRING ON EL. BOARD	Electrical board wires are identified by numbered labels. The reference numbers are indicated in the unit's wiring scheme.	Facilitate maintenance interventions to the electrical board connections.	ALL
382 PWR WIRINGS ACC.TO UK REQUEST		Facilitate maintenance interventions to the electrical board connections.	ALL
383 NUMBERED WIRINGS+UK REQUESTS	Electrical board wires are identified by numbered labels. The reference numbers are indicated in the unit's wiring scheme.	Facilitate maintenance interventions to the electrical board connections.	ALL
3410 AUTOMATIC CIRCUIT BREAKERS			
3412 AUTOM. CIRCUIT BREAK. ON LOADS	Over-current switch on the major electrical loads.	In case of overcurrent allows resetting of the switch without the replacement of relative fuses.	ALL
2410 PHASE SEQUENCE RELAY			
2411 WITH EXTERNAL PHASE SEQUENCE RELAY	Relay for checking mains phase-sequence	Protects loads against faults due to incorrect connection of mains	ALL
2412 PHASE SEQU. RELAY + OVER/UNDER VOLT. MONIT.	Relay for checking mains phase-sequence and voltage	The monitoring relay protects loads against faults due to incorrect connection of mains, and it monitors whether it exceeds or falls below a specified voltage in a three-phase network.	ALL

OPTIONS

OPTIONS	DESCRIPTIONS	BENEFITS	AVAILABLE FOR MODELS
3600 ON/OFF COMPRESSOR SIGNAL			
3601 COMPRESSOR OPERATION SIGNAL	Auxiliary contacts providing a voltage-free signal.	Allows remote signalling of compressor's activation or remote control of any auxiliary loads.	ALL
6160 AUXILIARY INPUT			
6162 REMOTE SIGNAL DOUBLE SP	Allows to activate the Energy Saving set-point.	Allows to change the operating set-point according to a remote switch	ALL
6170 DEMAND LIMIT			
6171 INPUT REMOTE DEMAND LIMIT	Digital input (voltage free)	It permits to limit the unit's power absorption for safety reasons or in temporary situation.	ALL
1510 SOFT-STARTER			
1511 UNIT WITH SOFT-START	Electronic device adopted to manage the inrush current.	Break down of the inrush current compared to the direct motor start, lower motor windings' mechanical wear, avoidance of mains voltage fluctuations during starting, favourable sizing for the electrical system.	ALL
3300 COMPRESSOR REPHASING			
3301 COMPR.POWER FACTOR CORR.	Capacitors on the compressors' power inlet line.	The unit's average cos(phi) increases.	ALL
4180 REMOTE CONNECTION ARRANGEMENT			
4181 SERIAL CARD MODBUS	Interface module for ModBUS protocols.	Allows integration with BMS operating with ModBUS protocol.	ALL
4182 SERIAL CARD FOR LONWORKS	Interface module for Echelon systems.	Allows integration with BMS operating with LonWorks protocols	ALL
4184 SERIAL CARD BACNET MS/TP RS485	Interface module for BACnet protocols.	Allows integration with BMS operating with BACnet protocol.	ALL
4185 SERIAL CARD FOR BACNET OVER IP	Interface module for BACnet OVER-IP protocols.	Allows to interconnect BACnet devices over Internet Protocol within wide-area networks.	ALL
4186 SERIAL CARD FOR KONNEX	Protocol for KNX system	Allows integration with BMS operating with KNX protocol	ALL
4187 M-Net W3000 INTERFACE KIT	Interface kit for M-Net protocol.	Interface module to allow the integration of the unit with Mitsubishi Electric proprietary communication protocol M-Net.	ALL
4188 SERIAL CARD MODBUS TCP/IP	Interface module for ModBus TCP/IP protocol	Allows integration with BMS operating with ModBus TCP/IP protocol.	ALL
4189 SERIAL CARD SNMP	Interface module for SNMP protocol	Allows integration with BMS operating with SNMP protocol.	ALL
1470 MULTIFUNCTION CARD			
1431 NIGHT MODE	The option includes a related controller expansion board and dedicated terminal block.	Night mode is a system setting to limit maximum noise level of the unit. Noise level is reduced limiting maximum compressor frequency and fan speed.	ALL
1471 4951 + 1431	The option includes a related controller expansion board and dedicated terminal block.	Enables the functions corresponding to the indicated accessory codes.	ALL

OPTIONS

OPTIONS	DESCRIPTIONS	BENEFITS	AVAILABLE FOR MODELS
1472 4951 + 1431 + 4961	The option includes a related controller expansion board and dedicated terminal block (it is necessary to install a 3 way valve).	Enables the functions corresponding to the indicated accessory codes.	ALL
1473 4951 + 4961	The option includes a related controller expansion board and dedicated terminal block (it is necessary to install a 3 way valve).	Enables the functions corresponding to the indicated accessory codes.	ALL
1474 1431 + 4961	The option includes a related controller expansion board and dedicated terminal block (it is necessary to install a 3 way valve).	Enables the functions corresponding to the indicated accessory codes.	ALL
1475 4962 + 4951	The option includes a related controller expansion board and dedicated terminal block (it is necessary to install a 3 way valve).	Enables the functions corresponding to the indicated accessory codes.	ALL
1476 4962 + 1431	The option includes a related controller expansion board and dedicated terminal block (it is necessary to install a 3 way valve).	Enables the functions corresponding to the indicated accessory codes.	ALL
1477 4962 + 4951 + 1431	The option includes a related controller expansion board and dedicated terminal block (it is necessary to install a 3 way valve).	Enables the functions corresponding to the indicated accessory codes.	ALL
4951 WITH HYDRAULIC DECOUPLER PROBE	Water temperature probe on hydraulic decoupler.	The pump activation can be set by parameter according to the water temperature on buffer tank measuring by the sensor (in the systems with the primary and secondary circuits separated by a hydraulic decoupler), thus bringing significant pump consumption reduction during unit's stand-by.	ALL
4961 U.L.C.F. - WITH OR WITHOUT FIX SPEED PUMP	Option to be selected with the unit without pump/s or with fix speed pump/s (4703,4706,4707,4711,4712). The option includes a related controller expansion board and dedicated terminal block.	Guaranteed the start-up of the units with the option U.L.C. even when the critical working condition could generate an alarm. The W3000TE controller can manage a 3way mixing valve (not provided from MEHITS) by 0-10V signal for ensuring a dynamic control of the water temperature on user heat exchanger according to the operating limits allowed. This ensures the start-up and correct functioning of the unit into the envelope, also even critical whether condition.	ALL
4962 U.L.C.F. - WITH VARIABLE WATER FLOW	Option to be selected with the unit with variable speed pump/s (4713,4714,4717,4718,4722,4723). The option includes a related controller expansion board and dedicated terminal block.	Guaranteed the start-up of the units with the option U.L.C. even when the critical working condition could generate an alarm. The W3000TE controller can manage a 3way mixing valve (not provided from MEHITS) by 0-10V signal for ensuring a dynamic control of the water temperature on user heat exchanger according to the operating limits allowed. This ensures the start-up and correct functioning of the unit into the envelope, also even critical whether condition.	ALL

OPTIONS

OPTIONS	DESCRIPTIONS	BENEFITS	AVAILABLE FOR MODELS
1540 MULTI MANAGER			
1541 MM PRIORITY MASTER MM_PR	Multi Manager - Priority Master: integrated control of a group of chillers and chillers with free-cooling with up to 8 units with LAN logics and dynamic master. The unit is identified and parameterized as a Priority Master; therefore it is given preference in case of election of a new Master (in case of a failure of the current Master). At least one Priority Master must be present in the group. The maximum number of Priority Master units coincides with the number of connected units (up to 8). If you want to equip the group of chiller with auxiliary functions (e.g. 4-20 mA set point variation, pressure transducer for VPF system), each Priority Master requires auxiliary input signals. Consequently, for each Priority Master it is necessary to select these accessories from the price list and proceed with their wiring onsite. More details can be found in the data book and in the controls technical documentation.	It allows the management of a group of chillers and chillers with free-cooling (up to 8 units) via LAN with master/slave operating logic with dynamic master which always guarantees a back-up function to the network. The system makes other functions available such as load and stand-by unit management, resource use priority, unit start-up in sequence and group fast restart. For more details refer to the dedicated section of the data book.	ALL
1542 MM NON PRIORITY MASTER MM_N-PR	Multi Manager - Non Priority Master: integrated control of a group of chillers and chillers with free-cooling with up to 8 units with LAN logics and dynamic master. The unit is identified and parameterized as a Non-Priority Master. Non-Priority Master units can become Masters (in case of a failure of the current Master) if there are no more Priority Master units available. In this case, the functions provided by the auxiliary signals are suspended (e.g. 4-20 mA set point variation, VPF); these signals can only be processed by Priority Master units. More details can be found in the data book and in the controls technical documentation.	It allows the management of a group of chillers and chillers with free-cooling (up to 8 units) via LAN with master/slave operating logic with dynamic master which always guarantees a back-up function to the network. The system makes other functions available such as load and stand-by unit management, resource use priority, unit start-up in sequence and group fast restart. For more details refer to the dedicated section of the data book.	ALL
5920 MANAGEMENT & CONTROL SYSTEMS			
5922 ClimaPRO ModBUS RS485 - MID	This option includes the following devices on-board the unit panel: - MID certified network analyzer operating on ModBUS over RS-485 - Current transformers - W3000TE controller - Software release LA09 or later version.	This accessory allows to acquire the electrical data and the power absorbed by the unit and communicate with ClimaPRO via high level communication interface based on ModBUS over EIA RS-485. More specifically, the data collected are: power supply, current, frequency, power factor ($\cos\phi$), electrical power consumption, energy consumption. This specific energy meter model is MID certified and can therefore be used for billing applications. This option also ensures the compatibility between the units and ClimaPRO, thus allowing ClimaPRO to acquire all the main unit's operating variables and status by means of a high level communication interface to the controller installed onboard the unit panel.	ALL

OPTIONS

OPTIONS	DESCRIPTIONS	BENEFITS	AVAILABLE FOR MODELS
5923 ClimaPRO BacNET over IP	This option includes the following devices on-board the unit panel: - network analyzer operating on BACnet over IP - Current transformers - W3000TE controller - Software release LA09 or later version.	This accessory allows to acquire the electrical data and the power absorbed by the unit and communicate with ClimaPRO via high level communication interface based on BACnet over IP. More specifically, the data collected are: power supply, current, frequency, power factor ($\cos\phi$), electrical power consumption, energy consumption. This network analyzer is not MID certified and cannot therefore be used for billing applications. This option also ensures the compatibility between the units and ClimaPRO, thus allowing ClimaPRO to acquire all the main unit's operating variables and status by means of a high level communication interface to the controller installed onboard the unit panel.	ALL
5924 ENERGY METER FOR BMS	This option includes the following devices on-board the unit panel: - network analyzer with display operating on ModBUS protocol over RS-485 (without certification MID) - current transformers.	This accessory allows to acquire the electrical data and the power absorbed by the unit and send them via RS-485 bus to the BMS for energy metering.	ALL
5925 ENERGY METER FOR W3000	This option includes all following devices on-board the unit panel: - network analyzer with display, already cabled to unit's controller - current transformers.	This option allows to acquire the electrical data and the power absorbed by the unit. The figures are accessible through the unit's W3000 interface, and be sent to the BMS via several protocols by selecting the dedicated serial card in the option list.	ALL
5940 SETP. COMPENSATION OUT. TEMP.			
5941 WITH SETPOINT COMPENSATION	This option includes an outside air sensor to be installed outside the building and enable the climatic curve function.	An outside air temperature probe, available as option, controls the system water temperature set point based on heating and cooling (reversible units) climatic curves. Delivering water at different temperatures to the terminals based on the outside air temperature achieves high seasonal efficiency ratios and provides considerable savings in running costs.	ALL
3390 ANTICONDENSATE HEATER EL.BOARD			
3391 ELECTRIC HEATER ON EL. BOARD	Electrical heater fed directly from the unit, is automatically activated at temperatures internal QE below 30 ° C (off state at higher than 40 ° C).	It avoids the risk of humidity condensation on the electrical panel.	ALL
990 CONDENSING COIL			
876 E-COATING MICROCHANNEL COILS	The heat exchanger is completely treated by electrolysis so as to create a protective layer of epoxy polymer on the surface, with the following characteristics: - over 3120 hours of salt spray protection as per ASTM G85-02 A3 (SWAAT); - polyurethane surface protection against UV rays.	Provides a very high resistance against corrosion, also in very aggressive environments. For further information please refer to the Guidelines "Finned coil heat exchangers and protection against corrosion", available in the download section of the website www.melcohit.com/EN/Download/Corporate/GUIDELINES or contact our sales department.	ALL
820 FAN CONTROL			
808 EC FANS	Electronically commutated fans (EC fans). The brushless motor, governed by a special controller, continuously adjust fans' speed.	Reduced energy consumption and minimized current's absorption during start-up phase. The efficiency is increased by approximately: +1% of EER and +4/5% of ESEER. The noise reduces proportionally to the unit's partialization.	ALL

OPTIONS

OPTIONS	DESCRIPTIONS	BENEFITS	AVAILABLE FOR MODELS
818 OVERSIZED EC FANS	Fans with oversized EC motor	Extends the operating limits of the unit. Further information in the dedicated databook section.	ALL
1400 HP AND LP GAUGES			
1401 HP AND LP GAUGES	High and low pressure gauges	Allows immediate reading of the pressure values on both low and high pressure circuits	ALL
5040 COMPRESSOR SUCTION AND DISCHARGE VALVE			
5042 COMPRESSOR SUCTION AND DISCHARGE VALVE	Shut-off valve on compressor's suction and discharge circuit.	Simplifies maintenance activities	ALL
1960 PRESSURE RELIEF VALVES			
1961 DUAL RELIEF VALVES WITH SWITCH	Dual relief valve with switch	Allows to unselect a relief valve in order to service the unit avoiding medium or long inoperative periods	ALL
2660 HEAT-EXCHANGER INSULATION			
2641 EXTRA INSULATION ON EXCHANGERS	Increased thermal insulation on the heat exchanger: 20 mm thick closed-cell expanded polyurethane.	Reduces heat losses and prevent from condensate problems.	ALL
4700 EV - HYDRONIC MODULE			
4706 EV - 1 PUMP 2P LH (FIX SPEED)	Evaporator hydronic module, compatible with constant flow control. The unit is provided with 1 fixed speed pump, with 2-pole motor. Residual head of 100 kPa approximately. Specifications and characteristic curves are available in the dedicated bulletin section.	The hydronic module includes the pumps and the main water circuit components, thus optimizing hydraulic and electrical installation space, time and costs.	ALL
4707 EV - 1 PUMP 2P HH (FIX SPEED)	Evaporator hydronic module, compatible with constant flow control. The unit is provided with 1 fixed speed pump, with 2-pole motor. Residual head of 200 kPa approximately. Specifications and characteristic curves are available in the dedicated bulletin section.	The hydronic module includes the pumps and the main water circuit components, thus optimizing hydraulic and electrical installation space, time and costs.	ALL
4711 EV - 2 PUMPS 2P LH (FIX SPEED)	Evaporator hydronic module, compatible with constant flow control. The unit is provided with 2 fixed speed pumps, with 2-pole motor. Residual head of 100 kPa approximately. The pumps are controlled in duty/standby, with running hours equalization and changeover on device failure. Specifications and characteristic curves are available in the dedicated bulletin section.	The hydronic module includes the pumps and the main water circuit components, thus optimizing hydraulic and electrical installation space, time and costs.	ALL
4712 EV - 2 PUMPS 2P HH (FIX SPEED)	Evaporator hydronic module, compatible with constant flow control. The unit is provided with 2 fixed speed pumps, with 2-pole motor. Residual head of 200 kPa approximately. The pumps are controlled in duty/standby, with running hours equalization and changeover on device failure. Specifications and characteristic curves are available in the dedicated bulletin section.	The hydronic module includes the pumps and the main water circuit components, thus optimizing hydraulic and electrical installation space, time and costs.	ALL
4713 EV - RELAY 1 PUMP + 0-10V SIG	Evaporator hydronic module, compatible with constant or variable flow control. The unit is provided with 1 relay and a 0-10V signal terminal to control the activation and the speed of 1 external variable speed pump.	The hydronic module controls the external pumps with the unit controller logic.	ALL

OPTIONS

OPTIONS	DESCRIPTIONS	BENEFITS	AVAILABLE FOR MODELS
4714 EV - RELAY 2 PUMPS + 0-10V SIG	Evaporator hydronic module, compatible with constant or variable flow control. The unit is provided with 2 relays and a 0-10V signal terminal to control the activation and the speed of 2 external variable speed pump. The pumps are controlled in duty/standby, with running hours equalization and changeover on device failure.	The hydronic module controls the external pumps with the unit controller logic.	ALL
4717 EV - 1 PUMP 2P LH (VAR SPEED)	Evaporator hydronic module, compatible with constant or variable flow control. The unit is provided with 1 variable speed pump, with 2-pole motor. Residual head of 100 kPa approximately. Specifications and characteristic curves are available in the dedicated bulletin section.	The hydronic module includes the pumps and the main water circuit components, thus optimizing hydraulic and electrical installation space, time and costs.	ALL
4718 EV - 1 PUMP 2P HH (VAR SPEED)	Evaporator hydronic module, compatible with constant or variable flow control. The unit is provided with 1 variable speed pump, with 2-pole motor. Residual head of 200 kPa approximately. Specifications and characteristic curves are available in the dedicated bulletin section.	The hydronic module includes the pumps and the main water circuit components, thus optimizing hydraulic and electrical installation space, time and costs.	ALL
4722 EV - 2 PUMPS 2P LH (VAR SPEED)	Evaporator hydronic module, compatible with constant or variable flow control. The unit is provided with 2 variable speed pumps, with 2-pole motor. Residual head of 100 kPa approximately. The pumps are controlled in duty/standby, with running hours equalization and changeover on device failure. Specifications and characteristic curves are available in the dedicated bulletin section.	The hydronic module includes the pumps and the main water circuit components, thus optimizing hydraulic and electrical installation space, time and costs.	ALL
4723 EV - 2 PUMPS 2P HH (VAR SPEED)	Evaporator hydronic module, compatible with constant or variable flow control. The unit is provided with 2 variable speed pumps, with 2-pole motor. Residual head of 200 kPa approximately. The pumps are controlled in duty/standby, with running hours equalization and changeover on device failure. Specifications and characteristic curves are available in the dedicated bulletin section.	The hydronic module includes the pumps and the main water circuit components, thus optimizing hydraulic and electrical installation space, time and costs.	ALL
4860 EV - PRIMARY FLOW CONTROL			
4861 EV - CONSTANT FLOW	Evaporator water flow control (plant primary circuit): constant flow. Compatible with hydronic modules without regulation devices (no pumps, no contacts), with ON/OFF regulation devices (relays) or with fixed speed pumps (codes: 4701, 4702, 4703, 4704, 4705, 4706, 4707, 4708, 4709, 4711, 4712 - hydronic modules availability depends on unit model).	The unit is set up to operate with a constant water flow in the heat exchanger (plant primary circuit). This is the only option available in case of unit without any water flow regulation devices (no pumps, no contacts), which means with water flow control provided by others. In case of unit with ON/FF regulation devices or fixed speed pumps, the unit controller manages the pump activation to reduce pump consumption.	ALL

OPTIONS

OPTIONS	DESCRIPTIONS	BENEFITS	AVAILABLE FOR MODELS
<p>4862 EV - CONSTANT FLOW (PARAMETER)</p>	<p>Evaporator water flow control (plant primary circuit): constant flow (parameter set). Compatible with hydronic modules with modulating regulation devices (0-10V signal) or with variable speed pumps (codes: 4713, 4714, 4715, 4716, 4717, 4718, 4719, 4721, 4722, 4723 - hydronic modules availability depends on unit model).</p>	<p>The unit is set up to operate with a constant water flow in the heat exchanger (plant primary circuit). The unit controller manages the pump activation to reduce pump consumption. The pump speed is adjusted via 0-10V signal. The option provides the possibility to set the pump speed with a controller parameter. Once set, the speed pump remains constant until the next parameter adjustment. The parameter set constant flow control is useful during the unit installation and commissioning, to adjust water flow and pressure head according to the real plant characteristics.</p>	<p>ALL</p>
<p>4864 EV – VPF (w/o DP)(SU, MM_PR)</p>	<p>Evaporator water flow control (plant primary circuit): variable flow (delta P control). Only for single unit systems or unit with option 1541 (Multi Manager - Priority Master) if available. Compatible with hydronic modules with modulating regulation devices (0-10V signal) or with variable speed pumps (codes: 4713, 4714, 4715, 4716, 4717, 4718, 4719, 4721, 4722, 4723 - hydronic modules availability depends on unit model). The option includes: differential pressure transducer on the unit's heat exchanger and related controller expansion board, controller expansion board to read the plant side differential pressure transducer (4-20mA signal) and manage the hydraulic by-pass valve opening (0-10V signal). Compulsory equipment, supplied by others: plant side differential pressure transducer, plant side hydraulic by-pass valve.</p>	<p>The unit is set up to operate with a variable water flow in the heat exchanger (plant primary circuit). The unit controller manages the pump activation to reduce pump consumption. The pump speed is adjusted via 0-10V signal. The option provides a pump speed management based on the VPF (Variable Primary Flow) function. It keeps the delta P constant on the plant side (primary circuit), thus bringing significant pump consumption reduction during part load operation. The VPF function is applicable in systems with only the primary circuit. Further information available in the dedicated bulletin section.</p>	<p>ALL</p>
<p>4865 EV – VPF (w DP)(SU, MM_PR)</p>	<p>Evaporator water flow control (plant primary circuit): variable flow (delta P control). Only for single unit systems or unit with option 1541 (Multi Manager - Priority Master) if available. Compatible with hydronic modules with modulating regulation devices (0-10V signal) or with variable speed pumps (codes: 4713, 4714, 4715, 4716, 4717, 4718, 4719, 4721, 4722, 4723 - hydronic modules availability depends on unit model). The option includes: differential pressure transducer on the unit's heat exchanger and related controller expansion board, plant side differential pressure transducer (installation by others), controller expansion board to read the plant side differential pressure transducer (4-20mA signal) and manage the hydraulic by-pass valve opening (0-10V signal). Compulsory equipment, supplied by others: plant side hydraulic by-pass valve.</p>	<p>The unit is set up to operate with a variable water flow in the heat exchanger (plant primary circuit). The unit controller manages the pump activation to reduce pump consumption. The pump speed is adjusted via 0-10V signal. The option provides a pump speed management based on the VPF (Variable Primary Flow) function. It keeps the delta P constant on the plant side (primary circuit), thus bringing significant pump consumption reduction during part load operation. The VPF function is applicable in systems with only the primary circuit. Further information available in the dedicated bulletin section.</p>	<p>ALL</p>

OPTIONS

OPTIONS	DESCRIPTIONS	BENEFITS	AVAILABLE FOR MODELS
4866 EV – VPF (M3000, CPRO, MM_N-PR)	Evaporator water flow control (plant primary circuit): variable flow (delta P control). Only for multi-unit systems with external controller (Manager3000 or ClimaPRO) or unit with option 1542 (Multi Manager - Non Priority Master) if available. Compatible with hydronic modules with modulating regulation devices (0-10V signal) or with variable speed pumps (codes: 4713, 4714, 4715, 4716, 4717, 4718, 4719, 4721, 4722, 4723 - hydronic modules availability depends on unit model). The option includes: differential pressure transducer on the unit's heat exchanger and related controller expansion board. It shall be the customer responsibility to configure the multi-unit control system (Manager3000, ClimaPRO or Multi Manager Priority Master) with option VPF.	The unit is set up to operate with a variable water flow in the heat exchanger (plant primary circuit). The unit controller manages the pump activation to reduce pump consumption. The pump speed is adjusted via 0-10V signal. The option provides a pump speed management based on the VPF (Variable Primary Flow) function. It keeps the delta P constant on the plant side (primary circuit), thus bringing significant pump consumption reduction during part load operation. The VPF function is applicable in systems with only the primary circuit. Further information available in the dedicated bulletin section.	ALL
4867 EV - VPF.D (SU, MM_PR)	Evaporator water flow control (plant primary circuit): variable flow (delta T control). Only for single unit systems or unit with option 1541 (Multi Manager - Priority Master) if available. Compatible with hydronic modules with modulating regulation devices (0-10V signal) or with variable speed pumps (codes: 4713, 4714, 4715, 4716, 4717, 4718, 4719, 4721, 4722, 4723 - hydronic modules availability depends on unit model). The option includes: 2 plant side NTC temperature sensors (installation by others).	The unit is set up to operate with a variable water flow in the heat exchanger (plant primary circuit). The unit controller manages the pump activation to reduce pump consumption. The pump speed is adjusted via 0-10V signal. The option provides a pump speed management based on the VPF.D (Variable Primary Flow with Decoupler) function. It keeps the delta T constant on the plant side (primary circuit), thus bringing significant pump consumption reduction during part load operation. The VPF.D function is applicable in systems with the primary and secondary circuits separated by a hydraulic decoupler. Further information available in the dedicated bulletin section.	ALL
4868 EV - VPF.D(M3000, CPRO, MM_N-PR)	Evaporator water flow control (plant primary circuit): variable flow (delta T control). Only for multi-unit systems with external controller (Manager3000 or ClimaPRO) or unit with option 1542 (Multi Manager - Non Priority Master) if available. Compatible with hydronic modules with modulating regulation devices (0-10V signal) or with variable speed pumps (codes: 4713, 4714, 4715, 4716, 4717, 4718, 4719, 4721, 4722, 4723 - hydronic modules availability depends on unit model). It shall be the customer responsibility to configure the multi-unit control system (Manager3000, ClimaPRO or Multi Manager - Priority Master) with option VPF.D.	The unit is set up to operate with a variable water flow in the heat exchanger (plant primary circuit). The unit controller manages the pump activation to reduce pump consumption. The pump speed is adjusted via 0-10V signal. The option provides a pump speed management based on the VPF.D (Variable Primary Flow with Decoupler) function. It keeps the delta T constant on the plant side (primary circuit), thus bringing significant pump consumption reduction during part load operation. The VPF.D function is applicable in systems with the primary and secondary circuits separated by a hydraulic decoupler. Further information available in the dedicated bulletin section.	ALL

OPTIONS

OPTIONS	DESCRIPTIONS	BENEFITS	AVAILABLE FOR MODELS
4869 EV - VPF.E	Evaporator water flow control (plant primary circuit): variable flow (delta T control). Compatible with hydronic modules with modulating regulation devices (0-10V signal) or with variable speed pumps (codes: 4713, 4714, 4715, 4716, 4717, 4718, 4719, 4721, 4722, 4723 - hydronic modules availability depends on unit model).	The unit is set up to operate with a variable water flow in the heat exchanger (plant primary circuit). The unit controller manages the pump activation to reduce pump consumption. The pump speed is adjusted via 0-10V signal. The option provides a pump speed management based on the VPF.E function. It keeps the delta T constant on the plant side (primary circuit), thus bringing significant pump consumption reduction during part load operation. The VPF.E function is applicable in systems with only the primary circuit and with the hydraulic terminals equipped 3 way valve (by-pass). Further information available in the dedicated bulletin section.	ALL
4940 BUFFER TANK			
4941 EV - WITH BUFFER TANK	Buffer tank covered by a 20 mm thick insulation lining in closed-cell reticulated foam, which capacity depends on the unit size (see the dedicated table). In the dedicated section are described all the factory-mounted components included in the buffer tank system.	It helps to reach the plant water content required for the correct unit operation (see dedicated section "Hydraulic Data").	ALL
2430 PIPING KIT ANTIFREEZE HEATER			
2432 ANTIFREEZE PIPING, PUMPS	Electrical heaters on pipes and other hydraulic unit's components. This option is mandatory if the unit is supposed to work with outdoor temperature below 0°C.	It protects the unit against ice formation on its hydraulic components.	ALL
2433 ANTIFREEZE PIPING, PUMPS, TANK	Electrical heaters on pipes and other hydraulic unit's components. This option is mandatory if the unit is supposed to work with outdoor temperature below 0°C.		ALL
2910 HYDRAULIC CONNECTIONS			
2911 FLANGED HYDRAULIC CONNECTIONS	Grooved coupling with flanged counter-pipe user/source side.		ALL
2020 ANTI-INTRUSION GRILLS			
2021 ANTI-INTRUSION GRILLS	Anti-intrusions grills	Avoid the intrusion of solid bodies into the unit's structure.	ALL
2290 UNIT ENCLOSURE			
2312 UNIT WITH ACOUSTICAL ENCLOSURE	Compressor enclosure with soundproofing insulation in polyester fiber mat (thickness of 30 mm on sides and on top, 15 mm on bottom) If the hydronic is present, the pump enclosure is acoustically insulated: 15 mm thick Fiberform (polyester fibres)	Protects the main components of the unit and reduces the noise emissions	ALL
3430 REFRIGERANT LEAK DETECTOR			
3431 REFRIG. LEAK DETECTOR	Refrigerant leak detection system, supplied factory mounted and wired in the electrical board. In case of leak detection it will raise an alarm.	It promptly detects gas leakages	ALL
3433 GAS LEAK CONTACT + COMPR. OFF	Refrigerant leak detection system, supplied factory mounted and wired in the electrical board. In case of leak detection it will raise an alarm and stop the unit.	It promptly detects gas leakages and stops the unit	ALL

OPTIONS

OPTIONS	DESCRIPTIONS	BENEFITS	AVAILABLE FOR MODELS
1970 LONG DISTANCE TRANSPORTATION			
1971 REINFORCING BARS	Bars used to reinforce the structure	Improve resistance during long transportation	ALL
9970 PACKING			
9969 NYLON + WOODEN CRATE PACKING	Unit provided with wooden cage and covered with nylon		ALL
9971 WITHOUT PACKAGING	Unit provided with plastic supports		ALL
9979 CONTAINER PACKING	Unit provided with container slides and covered with nylon		ALL
9996 CONTAINER SLIDES	Unit provided with container slides		ALL
9999 SUPPORTS AND NYLON	Unit provided with plastic supports and covered with nylon		ALL

OPTIONS

Additional information - IMPORTANT -

1015 - Heat exchangers NSW certified

The certification is available for the evaporator only. If the certification is required also for the recovery heat exchanger (versions /D), please contact our sales department.

3301 - Compressor power factor correction

1511 - Unit with soft start

There is a mutual exclusion rule between the compressor rephrasing capacitors and the soft-start device. When both accessories are required together, a feasibility analysis is needed. If the configuration is available as a special execution, an extra-price may be quoted.

2312 - Unit with acoustical enclosure

Compressor compartment soundproofing insulation characteristics: polyester fiber mat (thickness of 30 mm on sides and on top, 15 mm on bottom). Pump/s soundproofing insulation characteristics: 15 mm thick Fiberform (polyester fibers).

Sound power reduction: -2 dB(A).

This option is not compatible with opt. 2282 – NR kit.

3431 - Refrigerant leak detector

3433 - Refrigerant leak detector + compressors off

The accessory requires the compressor enclosure (opt. 2312 or opt. 2282).

1431 - Night mode

With factory settings, the noise reduction achieved is: -3 dB(A).

818 – Oversized EC fans

This option allows to provide an available static pressure at the air discharge of the fans. Units with this option are suitable to win maximum air pressure drop of 150 Pa. From 100 Pa to 150 Pa there is a reduction of the maximum outdoor air ambient temperature. The maximum reduction at 150 Pa is 3°C.

This option is not compatible with opt. 2282 – NR kit.

9979 – Container packing

9996 – Container slides

The selection of one of these options is mandatory to let the units be shippable via container. These options provide low-profiled fans which are able to reduce the height of the units and permit the transport via container. The selection of these options increases the sound power level of the units of 1 dB(A).

1541 – Multi Manager – Priority Master

1541 – Multi Manager – Non-Priority Master

These options are not compatible with options:

5922 - ClimaPRO ModBUS RS485 – MID

5923 - ClimaPRO BacNET over IP.

1541 – Multi Manager – Priority Master

This option is not compatible with options:

4866 – EV-VPF (M3000, CPRO, MM N-PR) (VPF option for plants with Manager3000, ClimaPro, and for Non-Priority Master units).

4868 – EV-VPF.D(M3000, CPRO, MM N-PR) (VPF.D option for plants with Manager3000, ClimaPro, and for Non-Priority Master units).

1542 – Multi Manager – Non-Priority Master

This option is not compatible with options:

4864 – EV-VPF (w/o DP)(SU, MM PR) (VPF option for plants with a Single Unit or for Priority Master units – plant side differential pressure transducer non included).

4865 – EV-VPF (w DP)(SU, MM PR) (VPF option for plants with a Single Unit or for Priority Master units – plant side differential pressure transducer excluded).

4867 – EV-VPF.D (SU, MM PR) (VPF.D option for plants with a Single Unit or for Priority Master units).

OPTIONS

Chiller Plant Control with Active Optimization System

ClimaPRO System Manager

ClimaPRO System Manager represents the state-of-the-art platform for chiller plant management and control. ClimaPRO ensures to actively optimize the entire chiller plant by managing and adjusting each component directly involved in the production and the distribution of the heating and the cooling energies, therefore involving chillers and heat pumps, pumping groups as well as the source-side devices like, for example, the cooling towers.

In particular, ClimaPRO measures in real-time all the operating variables from the field, for each individual device and each of the main system branches, by using serial communication lines as well as dedicated analogue signals.

The acquired data are then compared with the design data of each single unit at any different working conditions, thus allowing to implement control strategies based on dynamic algorithms which take into account the real operating conditions.

On the basis of these values, an advanced diagnostic module also allows to assess the level of efficiency for each individual unit, translating data into easy-to-read information in order to simplify and optimize the maintenance activities.

The "Chart Builder" software module allows to display the trends of the main operating variables. The "Reporting" module allows to send reports to selected users, including data and system's status of the main devices as well as to perform calculation of the energy indexes for each single unit and for the entire chiller plant.

The accessibility to ClimaPRO System Manager is ensured by an integrated web server that makes it visible from any computer equipped with a web browser, either locally or remotely.



5.1 GENERAL TECHNICAL DATA

NX2-G06 / K

[SI System]

NX2-G06 / K		0404	0424	0464	0515	0576	0585	0636	0676	0706	0768	
Power supply		V/ph/Hz 400/3/50 400/3/50 400/3/50 400/3/50 400/3/50 400/3/50 400/3/50 400/3/50 400/3/50 400/3/50										
PERFORMANCE												
COOLING ONLY (GROSS VALUE)												
Cooling capacity	(1)	kW	379,1	398,9	437,0	488,0	538,9	546,7	597,9	636,3	656,5	720,5
Total power input	(1)	kW	115,6	122,6	136,9	152,1	167,3	168,6	183,8	198,1	200,3	218,0
EER	(1)	kW/kW	3,279	3,254	3,192	3,208	3,221	3,243	3,253	3,212	3,278	3,305
ESEER	(1)	kW/kW										
COOLING ONLY (EN14511 VALUE)												
Cooling capacity	(1)(2)	kW	378,6	398,5	436,5	487,5	538,3	546,2	597,3	635,7	655,8	719,8
EER	(1)(2)	kW/kW	3,220	3,210	3,140	3,160	3,170	3,200	3,210	3,170	3,230	3,260
ESEER	(1)(2)	kW/kW	-	-	-	-	-	-	-	-	-	-
COOLING WITH PARTIAL RECOVERY												
Cooling capacity	(3)	kW	393,3	413,9	453,4	506,3	559,1	567,2	620,3	660,2	681,1	747,5
Total power input	(3)	kW	112,0	118,7	132,5	147,2	162,0	163,3	178,0	191,8	194,0	211,2
Desuperheater heating capacity	(3)	kW	93,04	99,26	112,0	123,9	135,8	137,0	148,8	161,6	161,9	174,2
EXCHANGERS												
HEAT EXCHANGER USER SIDE IN REFRIGERATION												
Water flow	(1)	l/s	18,13	19,08	20,90	23,34	25,77	26,14	28,59	30,43	31,39	34,45
Pressure drop at the heat exchanger	(1)	kPa	61,8	48,6	58,3	55,1	67,1	42,5	50,9	49,2	52,4	56,9
PARTIAL RECOVERY USER SIDE IN REFRIGERATION												
Water flow	(3)	l/s	4,491	4,791	5,408	5,979	6,555	6,611	7,184	7,801	7,813	8,411
Pressure drop at the heat exchanger	(3)	kPa	30,6	30,0	38,3	36,6	40,7	35,1	38,1	45,0	45,1	40,3
REFRIGERANT CIRCUIT												
Compressors nr.		N°	4	4	4	5	6	5	6	6	6	8
Number of capacity steps		N°	4	4	4	5	6	5	6	6	6	8
No. Circuits		N°	2	2	2	2	2	2	2	3	2	4
Regulation			STEPS STEPS STEPS STEPS STEPS STEPS STEPS STEPS STEPS STEPS STEPS									
Min. capacity step		%	25	25	25	20	17	20	17	17	17	12,5
Refrigerant			R454B	R454B	R454B	R454B	R454B	R454B	R454B	R454B	R454B	R454B
Refrigerant charge		kg	46,6	51,5	51,7	59,6	64,4	72,0	74,8	75,1	85,6	88,5
Oil charge		kg	21,2	21,2	21,2	26,5	31,8	26,5	31,8	31,8	31,8	42,4
Rc (ASHRAE)	(4)	kg/kW	0,12	0,13	0,12	0,12	0,12	0,13	0,13	0,12	0,13	0,12
FANS												
Quantity		N°	3	3	3	4	4	3	4	3	5	3
Air flow		m³/s	35,66	34,09	34,09	39,77	45,45	45,45	51,13	51,13	56,81	69,90
Fans power input		kW	1,90	1,90	1,90	1,90	1,90	1,90	1,90	1,90	1,90	1,90
NOISE LEVEL												
Sound Pressure	(5)	dB(A)	62	62	62	62	63	63	62	62	63	63
Sound power level in cooling	(6)(7)	dB(A)	94	94	94	94	95	95	95	95	96	96
SIZE AND WEIGHT												
A	(8)	mm	3905	3905	3905	5080	5080	5080	6255	6255	6255	7430
B	(8)	mm	2260	2260	2260	2260	2260	2260	2260	2260	2260	2260
H	(8)	mm	2560	2560	2560	2560	2560	2560	2560	2560	2560	2560
Operating weight	(8)	kg	2590	2620	2660	3190	3420	3500	3940	3980	4100	4970

Notes:

- 1 Plant (side) cooling exchanger water (in/out) 12,00°C/7,00°C; Source (side) heat exchanger air (in) 35,0°C.
- 2 Values in compliance with EN14511
- 3 Plant (side) cooling exchanger water (in/out) 12,00°C/7,00°C; Source (side) heat exchanger air (in) 35,0°C; Plant (side) heat exchanger recovery water (in/out) 40,00°C/45,00°C.
- 4 Rated in accordance with AHRI Standard 550/590
- 5 Average sound pressure level at 10m distance, unit in a free field on a reflective surface; non-binding value calculated from the sound power level.
- 6 Sound power on the basis of measurements taken in compliance with ISO 9614.
- 7 Sound power level in cooling, outdoors.
- 8 Unit in standard configuration, without optional accessories.

- Not available

Data certified in EUROVENT

GENERAL TECHNICAL DATA
NX2-G06 / K

[SI System]

NX2-G06 / K		0808	0848	0898	0928	
Power supply		V/ph/Hz	400/3/50	400/3/50	400/3/50	400/3/50
PERFORMANCE						
COOLING ONLY (GROSS VALUE)						
Cooling capacity	(1)	kW	759,5	798,1	835,5	867,1
Total power input	(1)	kW	231,4	245,1	259,3	273,5
EER	(1)	kW/kW	3,282	3,256	3,222	3,170
ESEER	(1)	kW/kW				
COOLING ONLY (EN14511 VALUE)						
Cooling capacity	(1)(2)	kW	758,8	797,4	834,8	866,3
EER	(1)(2)	kW/kW	3,230	3,220	3,180	3,130
ESEER	(1)(2)	kW/kW	-	-	-	-
COOLING WITH PARTIAL RECOVERY						
Cooling capacity	(3)	kW	788,0	828,0	866,9	899,6
Total power input	(3)	kW	224,1	237,3	251,0	264,8
Desuperheater heating capacity	(3)	kW	186,2	198,4	211,1	223,8
EXCHANGERS						
HEAT EXCHANGER USER SIDE IN REFRIGERATION						
Water flow	(1)	l/s	36,32	38,17	39,96	41,46
Pressure drop at the heat exchanger	(1)	kPa	63,3	47,2	51,7	55,7
PARTIAL RECOVERY USER SIDE IN REFRIGERATION						
Water flow	(3)	l/s	8,988	9,579	10,19	10,80
Pressure drop at the heat exchanger	(3)	kPa	34,6	36,9	41,7	46,9
REFRIGERANT CIRCUIT						
Compressors nr.		N°	8	8	8	8
Number of capacity steps		N°	8	8	8	8
No. Circuits		N°	4	4	4	4
Regulation			STEPS	STEPS	STEPS	STEPS
Min. capacity step		%	12,5	12,5	12,5	12,5
Refrigerant			R454B	R454B	R454B	R454B
Refrigerant charge		kg	95,1	104	106	106
Oil charge		kg	42,4	42,4	42,4	42,4
Rc (ASHRAE)	(4)	kg/kW	0,13	0,13	0,13	0,12
FANS						
Quantity		N°	3	3	3	3
Air flow		m³/s	71,33	68,18	68,18	68,18
Fans power input		kW	1,90	1,90	1,90	1,90
NOISE LEVEL						
Sound Pressure	(5)	dB(A)	63	64	64	64
Sound power level in cooling	(6)(7)	dB(A)	96	97	97	97
SIZE AND WEIGHT						
A	(8)	mm	7430	7430	7430	7430
B	(8)	mm	2260	2260	2260	2260
H	(8)	mm	2560	2560	2560	2560
Operating weight	(8)	kg	5010	5080	5120	5150

Notes:

- 1 Plant (side) cooling exchanger water (in/out) 12,00°C/7,00°C; Source (side) heat exchanger air (in) 35,0°C.
- 2 Values in compliance with EN14511
- 3 Plant (side) cooling exchanger water (in/out) 12,00°C/7,00°C; Source (side) heat exchanger air (in) 35,0°C; Plant (side) heat exchanger recovery water (in/out) 40,00°C/45,00°C.
- 4 Rated in accordance with AHRI Standard 550/590
- 5 Average sound pressure level at 10m distance, unit in a free field on a reflective surface; non-binding value calculated from the sound power level.
- 6 Sound power on the basis of measurements taken in compliance with ISO 9614.
- 7 Sound power level in cooling, outdoors.
- 8 Unit in standard configuration, without optional accessories.

- Not available

Data certified in EUROVENT

GENERAL TECHNICAL DATA
NX2-G06 / A

[SI System]

NX2-G06 / A		0404	0424	0464	0515	0576	0585	0636	0676	0706	0768	
Power supply		V/ph/Hz 400/3/50 400/3/50 400/3/50 400/3/50 400/3/50 400/3/50 400/3/50 400/3/50 400/3/50 400/3/50 400/3/50										
PERFORMANCE												
COOLING ONLY (GROSS VALUE)												
Cooling capacity	(1)	kW	380,1	400,0	439,8	490,2	540,8	548,6	599,7	639,0	658,6	721,1
Total power input	(1)	kW	111,3	117,1	129,4	145,0	161,1	161,7	177,4	188,0	194,1	211,0
EER	(1)	kW/kW	3,415	3,416	3,399	3,381	3,357	3,393	3,380	3,399	3,393	3,418
ESEER	(1)	kW/kW										
COOLING ONLY (EN14511 VALUE)												
Cooling capacity	(1)(2)	kW	379,6	399,5	439,2	489,7	540,2	548,1	599,1	638,4	658,0	720,5
EER	(1)(2)	kW/kW	3,350	3,370	3,340	3,330	3,300	3,350	3,330	3,350	3,350	3,370
ESEER	(1)(2)	kW/kW	-	-	-	-	-	-	-	-	-	-
COOLING WITH PARTIAL RECOVERY												
Cooling capacity	(3)	kW	394,3	415,0	456,2	508,6	561,1	569,2	622,2	663,0	683,3	748,2
Total power input	(3)	kW	107,9	113,5	125,4	140,6	156,1	156,7	171,9	182,2	188,1	204,6
Desuperheater heating capacity	(3)	kW	85,78	90,96	102,0	114,2	126,8	127,4	139,7	147,5	152,9	161,2
EXCHANGERS												
HEAT EXCHANGER USER SIDE IN REFRIGERATION												
Water flow	(1)	l/s	18,18	19,13	21,03	23,44	25,86	26,24	28,68	30,56	31,50	34,49
Pressure drop at the heat exchanger	(1)	kPa	62,1	48,8	59,0	55,6	67,6	42,8	51,2	49,6	52,7	57,0
PARTIAL RECOVERY USER SIDE IN REFRIGERATION												
Water flow	(3)	l/s	4,141	4,391	4,922	5,512	6,122	6,149	6,743	7,119	7,382	7,780
Pressure drop at the heat exchanger	(3)	kPa	26,0	25,2	31,7	31,1	35,5	30,4	33,6	37,4	40,3	34,5
REFRIGERANT CIRCUIT												
Compressors nr.		N°	4	4	4	5	6	5	6	6	6	8
Number of capacity steps		N°	4	4	4	5	6	5	6	6	6	8
No. Circuits		N°	2	2	2	2	2	2	2	3	2	4
Regulation			STEPS STEPS STEPS STEPS STEPS STEPS STEPS STEPS STEPS STEPS STEPS									
Min. capacity step		%	25	25	25	20	17	20	17	17	17	12,5
Refrigerant			R454B	R454B	R454B	R454B	R454B	R454B	R454B	R454B	R454B	R454B
Refrigerant charge		kg	56,1	59,9	62,7	76,5	77,9	80,8	88,8	94,1	98,8	107
Oil charge		kg	21,2	21,2	21,2	26,5	31,8	26,5	31,8	31,8	31,8	42,4
Rc (ASHRAE)	(4)	kg/kW	0,15	0,15	0,14	0,16	0,15	0,15	0,15	0,15	0,15	0,15
FANS												
Quantity		N°	4	4	4	4	5	4	5	4	6	4
Air flow		m³/s	47,55	45,45	45,45	51,13	56,81	56,81	62,50	68,18	68,18	93,19
Fans power input		kW	1,90	1,90	1,90	1,90	1,90	1,90	1,90	1,90	1,90	1,90
NOISE LEVEL												
Sound Pressure	(5)	dB(A)	63	63	63	62	63	63	63	64	64	64
Sound power level in cooling	(6)(7)	dB(A)	95	95	95	95	96	96	96	97	97	97
SIZE AND WEIGHT												
A	(8)	mm	5080	5080	5080	6255	6255	6255	7430	7430	7430	9780
B	(8)	mm	2260	2260	2260	2260	2260	2260	2260	2260	2260	2260
H	(8)	mm	2560	2560	2560	2560	2560	2560	2560	2560	2560	2560
Operating weight	(8)	kg	2930	2960	3000	3600	3830	3900	4290	4430	4450	5660

Notes:

- 1 Plant (side) cooling exchanger water (in/out) 12,00°C/7,00°C; Source (side) heat exchanger air (in) 35,0°C.
- 2 Values in compliance with EN14511
- 3 Plant (side) cooling exchanger water (in/out) 12,00°C/7,00°C; Source (side) heat exchanger air (in) 35,0°C; Plant (side) heat exchanger recovery water (in/out) 40,00°C/45,00°C.
- 4 Rated in accordance with AHRI Standard 550/590
- 5 Average sound pressure level at 10m distance, unit in a free field on a reflective surface; non-binding value calculated from the sound power level.
- 6 Sound power on the basis of measurements taken in compliance with ISO 9614.
- 7 Sound power level in cooling, outdoors.
- 8 Unit in standard configuration, without optional accessories.

- Not available

Data certified in EUROVENT

GENERAL TECHNICAL DATA
NX2-G06 / A

[SI System]

NX2-G06 / A		0808	0848	0898	0928	
Power supply		V/ph/Hz	400/3/50	400/3/50	400/3/50	400/3/50
PERFORMANCE						
COOLING ONLY (GROSS VALUE)						
Cooling capacity	(1)	kW	762,2	801,1	839,7	872,3
Total power input	(1)	kW	222,5	234,3	246,4	258,3
EER	(1)	kW/kW	3,426	3,419	3,408	3,377
ESEER	(1)	kW/kW				
COOLING ONLY (EN14511 VALUE)						
Cooling capacity	(1)(2)	kW	761,5	800,4	839,0	871,6
EER	(1)(2)	kW/kW	3,370	3,380	3,360	3,330
ESEER	(1)(2)	kW/kW	-	-	-	-
COOLING WITH PARTIAL RECOVERY						
Cooling capacity	(3)	kW	790,8	831,1	871,2	905,0
Total power input	(3)	kW	215,8	227,2	238,8	250,3
Desuperheater heating capacity	(3)	kW	171,5	182,0	192,8	203,5
EXCHANGERS						
HEAT EXCHANGER USER SIDE IN REFRIGERATION						
Water flow	(1)	l/s	36,45	38,31	40,16	41,72
Pressure drop at the heat exchanger	(1)	kPa	63,7	47,6	52,2	56,4
PARTIAL RECOVERY USER SIDE IN REFRIGERATION						
Water flow	(3)	l/s	8,278	8,787	9,305	9,821
Pressure drop at the heat exchanger	(3)	kPa	29,3	31,0	34,8	38,7
REFRIGERANT CIRCUIT						
Compressors nr.		N°	8	8	8	8
Number of capacity steps		N°	8	8	8	8
No. Circuits		N°	4	4	4	4
Regulation			STEPS	STEPS	STEPS	STEPS
Min. capacity step		%	12,5	12,5	12,5	12,5
Refrigerant			R454B	R454B	R454B	R454B
Refrigerant charge		kg	129	129	129	129
Oil charge		kg	42,4	42,4	42,4	42,4
Rc (ASHRAE)	(4)	kg/kW	0,17	0,16	0,16	0,15
FANS						
Quantity		N°	4	4	4	4
Air flow		m³/s	95,10	90,90	90,90	90,90
Fans power input		kW	1,90	1,90	1,90	1,90
NOISE LEVEL						
Sound Pressure	(5)	dB(A)	64	65	65	65
Sound power level in cooling	(6)(7)	dB(A)	97	98	98	98
SIZE AND WEIGHT						
A	(8)	mm	9780	9780	9780	9780
B	(8)	mm	2260	2260	2260	2260
H	(8)	mm	2560	2560	2560	2560
Operating weight	(8)	kg	5720	5770	5810	5850

Notes:

- 1 Plant (side) cooling exchanger water (in/out) 12,00°C/7,00°C; Source (side) heat exchanger air (in) 35,0°C.
 - 2 Values in compliance with EN14511
 - 3 Plant (side) cooling exchanger water (in/out) 12,00°C/7,00°C; Source (side) heat exchanger air (in) 35,0°C; Plant (side) heat exchanger recovery water (in/out) 40,00°C/45,00°C.
 - 4 Rated in accordance with AHRI Standard 550/590
 - 5 Average sound pressure level at 10m distance, unit in a free field on a reflective surface; non-binding value calculated from the sound power level.
 - 6 Sound power on the basis of measurements taken in compliance with ISO 9614.
 - 7 Sound power level in cooling, outdoors.
 - 8 Unit in standard configuration, without optional accessories.
- Not available
- Data certified in EUROVENT

GENERAL TECHNICAL DATA

NX2-G06 / A + NR kit

[SI System]

NX2-G06 / A + NR kit		0404	0424	0464	0515	0576	0585	0636	0676	0706	0768	
Power supply		V/ph/Hz 400/3/50 400/3/50 400/3/50 400/3/50 400/3/50 400/3/50 400/3/50 400/3/50 400/3/50 400/3/50 400/3/50										
PERFORMANCE												
COOLING ONLY (GROSS VALUE)												
Cooling capacity	(1)	kW	379,7	399,2	437,6	487,8	538,8	546,4	597,3	636,5	655,3	720,4
Total power input	(1)	kW	111,9	118,6	132,5	148,5	164,5	165,6	181,6	191,7	198,7	210,9
EER	(1)	kW/kW	3,393	3,366	3,303	3,285	3,275	3,300	3,289	3,320	3,298	3,416
ESEER	(1)	kW/kW										
COOLING ONLY (EN14511 VALUE)												
Cooling capacity	(1)(2)	kW	379,2	398,7	437,0	487,3	538,1	545,9	596,7	635,9	654,7	719,8
EER	(1)(2)	kW/kW	3,330	3,320	3,250	3,240	3,220	3,260	3,240	3,280	3,250	3,370
ESEER	(1)(2)	kW/kW	-	-	-	-	-	-	-	-	-	-
COOLING WITH PARTIAL RECOVERY												
Cooling capacity	(3)	kW	393,9	414,2	454,0	506,1	559,0	566,9	619,7	660,4	679,9	747,4
Total power input	(3)	kW	108,3	114,8	128,2	143,7	159,1	160,2	175,7	185,5	192,3	204,2
Desuperheater heating capacity	(3)	kW	91,51	97,49	109,9	123,2	136,4	137,3	150,6	158,6	164,9	171,5
EXCHANGERS												
HEAT EXCHANGER USER SIDE IN REFRIGERATION												
Water flow	(1)	l/s	18,16	19,09	20,92	23,33	25,76	26,13	28,56	30,44	31,34	34,45
Pressure drop at the heat exchanger	(1)	kPa	62,0	48,6	58,4	55,0	67,1	42,5	50,8	49,2	52,2	56,9
PARTIAL RECOVERY USER SIDE IN REFRIGERATION												
Water flow	(3)	l/s	4,417	4,706	5,306	5,946	6,582	6,629	7,270	7,654	7,957	8,280
Pressure drop at the heat exchanger	(3)	kPa	29,6	29,0	36,8	36,2	41,0	35,3	39,0	43,3	46,8	39,1
REFRIGERANT CIRCUIT												
Compressors nr.		N°	4	4	4	5	6	5	6	6	6	8
Number of capacity steps		N°	4	4	4	5	6	5	6	6	6	8
No. Circuits		N°	2	2	2	2	2	2	2	3	2	4
Regulation			STEPS STEPS STEPS STEPS STEPS STEPS STEPS STEPS STEPS STEPS STEPS									
Min. capacity step		%	25	25	25	20	17	20	17	17	17	12,5
Refrigerant			R454B	R454B	R454B	R454B	R454B	R454B	R454B	R454B	R454B	R454B
Refrigerant charge		kg	56,1	59,9	62,7	76,5	77,9	80,8	88,8	94,1	98,8	107
Oil charge		kg	21,2	21,2	21,2	26,5	31,8	26,5	31,8	31,8	31,8	42,4
Rc (ASHRAE)	(4)	kg/kW	0,15	0,15	0,14	0,16	0,15	0,15	0,15	0,15	0,15	0,15
FANS												
Quantity		N°	4	4	4	4	5	4	5	4	6	4
Air flow		m³/s	47,55	45,45	45,45	51,13	56,81	56,81	62,50	68,18	68,18	93,19
Fans power input		kW	1,17	1,17	1,17	1,17	1,17	1,17	1,17	1,17	1,17	1,17
NOISE LEVEL												
Sound Pressure	(5)	dB(A)	54	54	55	54	54	55	55	55	56	57
Sound power level in cooling	(6)(7)	dB(A)	86	86	87	87	87	88	88	88	89	90
SIZE AND WEIGHT												
A	(8)	mm	5080	5080	5080	6255	6255	6255	7430	7430	7430	9780
B	(8)	mm	2260	2260	2260	2260	2260	2260	2260	2260	2260	2260
H	(8)	mm	2560	2560	2560	2560	2560	2560	2560	2560	2560	2560
Operating weight	(8)	kg	2930	2960	3000	3600	3830	3900	4290	4430	4450	5660

Notes:

- 1 Plant (side) cooling exchanger water (in/out) 12,00°C/7,00°C; Source (side) heat exchanger air (in) 35,0°C.
- 2 Values in compliance with EN14511
- 3 Plant (side) cooling exchanger water (in/out) 12,00°C/7,00°C; Source (side) heat exchanger air (in) 35,0°C; Plant (side) heat exchanger recovery water (in/out) 40,00°C/45,00°C.
- 4 Rated in accordance with AHRI Standard 550/590
- 5 Average sound pressure level at 10m distance, unit in a free field on a reflective surface; non-binding value calculated from the sound power level.
- 6 Sound power on the basis of measurements taken in compliance with ISO 9614.
- 7 Sound power level in cooling, outdoors.
- 8 Unit in standard configuration, without optional accessories.

- Not available

Data certified in EUROVENT

GENERAL TECHNICAL DATA
NX2-G06 / A + NR kit

[SI System]

NX2-G06 / A + NR kit		0808	0848	0898	0928	
Power supply		V/ph/Hz 400/3/50 400/3/50 400/3/50 400/3/50				
PERFORMANCE						
COOLING ONLY (GROSS VALUE)						
Cooling capacity	(1)	kW	760,7	798,7	837,2	868,8
Total power input	(1)	kW	223,9	237,3	250,9	264,5
EER	(1)	kW/kW	3,397	3,366	3,337	3,285
ESEER	(1)	kW/kW				
COOLING ONLY (EN14511 VALUE)						
Cooling capacity	(1)(2)	kW	760,0	798,1	836,5	868,1
EER	(1)(2)	kW/kW	3,340	3,320	3,290	3,240
ESEER	(1)(2)	kW/kW	-	-	-	-
COOLING WITH PARTIAL RECOVERY						
Cooling capacity	(3)	kW	789,2	828,7	868,6	901,4
Total power input	(3)	kW	216,7	229,6	242,7	255,9
Desuperheater heating capacity	(3)	kW	183,1	195,1	207,2	219,4
EXCHANGERS						
HEAT EXCHANGER USER SIDE IN REFRIGERATION						
Water flow	(1)	l/s	36,38	38,20	40,04	41,55
Pressure drop at the heat exchanger	(1)	kPa	63,5	47,3	51,9	55,9
PARTIAL RECOVERY USER SIDE IN REFRIGERATION						
Water flow	(3)	l/s	8,840	9,418	10,00	10,59
Pressure drop at the heat exchanger	(3)	kPa	33,4	35,6	40,2	45,0
REFRIGERANT CIRCUIT						
Compressors nr.		N°	8	8	8	8
Number of capacity steps		N°	8	8	8	8
No. Circuits		N°	4	4	4	4
Regulation			STEPS	STEPS	STEPS	STEPS
Min. capacity step		%	12.5	12.5	12.5	12.5
Refrigerant			R454B	R454B	R454B	R454B
Refrigerant charge		kg	129	129	129	129
Oil charge		kg	42,4	42,4	42,4	42,4
Rc (ASHRAE)	(4)	kg/kW	0,17	0,16	0,16	0,15
FANS						
Quantity		N°	4	4	4	4
Air flow		m³/s	95,10	90,90	90,90	90,90
Fans power input		kW	1,17	1,17	1,17	1,17
NOISE LEVEL						
Sound Pressure	(5)	dB(A)	57	57	57	57
Sound power level in cooling	(6)(7)	dB(A)	90	90	90	90
SIZE AND WEIGHT						
A	(8)	mm	9780	9780	9780	9780
B	(8)	mm	2260	2260	2260	2260
H	(8)	mm	2560	2560	2560	2560
Operating weight	(8)	kg	5720	5770	5810	5850

Notes:

- 1 Plant (side) cooling exchanger water (in/out) 12,00°C/7,00°C; Source (side) heat exchanger air (in) 35,0°C.
- 2 Values in compliance with EN14511
- 3 Plant (side) cooling exchanger water (in/out) 12,00°C/7,00°C; Source (side) heat exchanger air (in) 35,0°C; Plant (side) heat exchanger recovery water (in/out) 40,00°C/45,00°C.
- 4 Rated in accordance with AHRI Standard 550/590
- 5 Average sound pressure level at 10m distance, unit in a free field on a reflective surface; non-binding value calculated from the sound power level.
- 6 Sound power on the basis of measurements taken in compliance with ISO 9614.
- 7 Sound power level in cooling, outdoors.
- 8 Unit in standard configuration, without optional accessories.

- Not available

Data certified in EUROVENT

6.1 TECHNICAL DATA SEASONAL EFFICIENCY IN COOLING (EN14825 VALUE)

[SI System]

ENERGY EFFICIENCY

SEASONAL EFFICIENCY IN COOLING (Reg. EU 2016/2281)

Ambient refrigeration

NX2-G06 / K			0404	0424	0464	0515	0576	0585	0636	0676	0706	0768
Prated,c	(1)	kW	378,6	398,5	436,5	487,5	538,3	546,2	597,3	635,7	655,8	719,8
SEER	(1) (2)	-	4,67	4,68	4,65	4,70	4,70	4,76	4,75	4,73	4,77	4,75
Performance ηs	(1) (3)	%	184,0	184,0	183,0	185,0	185,0	187,0	187,0	186,0	188,0	187,0
NX2-G06 / K			0808	0848	0898	0928						
Prated,c	(1)	kW	758,8	797,4	834,8	866,3						
SEER	(1) (2)	-	4,74	4,75	4,75	4,74						
Performance ηs	(1) (3)	%	187,0	187,0	187,0	187,0						

NX2-G06 / A			0404	0424	0464	0515	0576	0585	0636	0676	0706	0768
Prated,c	(1)	kW	379,6	399,5	439,2	489,7	540,2	548,1	599,1	638,4	658,0	720,5
SEER	(1) (2)	-	4,74	4,77	4,73	4,78	4,72	4,82	4,82	4,86	4,83	4,81
Performance ηs	(1) (3)	%	187,0	188,0	186,0	188,0	186,0	190,0	190,0	191,0	190,0	189,0
NX2-G06 / A			0808	0848	0898	0928						
Prated,c	(1)	kW	761,5	800,4	839,0	871,6						
SEER	(1) (2)	-	4,81	4,83	4,84	4,86						
Performance ηs	(1) (3)	%	189,0	190,0	190,0	191,0						

NX2-G06 / A + NR kit			0404	0424	0464	0515	0576	0585	0636	0676	0706	0768
Prated,c	(1)	kW	379,2	398,7	437,0	487,3	538,1	545,9	596,7	635,9	654,7	719,8
SEER	(1) (2)	-	4,73	4,76	4,72	4,76	4,70	4,81	4,80	4,85	4,81	4,81
Performance ηs	(1) (3)	%	186,0	187,0	186,0	188,0	185,0	190,0	189,0	191,0	189,0	189,0
NX2-G06 / A + NR kit			0808	0848	0898	0928						
Prated,c	(1)	kW	760,0	798,1	836,5	868,1						
SEER	(1) (2)	-	4,81	4,82	4,83	4,85						
Performance ηs	(1) (3)	%	189,0	190,0	190,0	191,0						

Notes:

(1) Parameter calculated according to [REGULATION (EU) N. 2016/2281]

(2) Seasonal energy efficiency ratio

(3) Seasonal space cooling energy efficiency

The units highlighted in this publication contain R454B [GWP₁₀₀ 466] fluorinated greenhouse gases.

Data certified in EUROVENT

7.1 OPERATING LIMITS

Version /K - /K+EC - /A+NR kit - /A+EC+NR kit Size 0404 - 0928

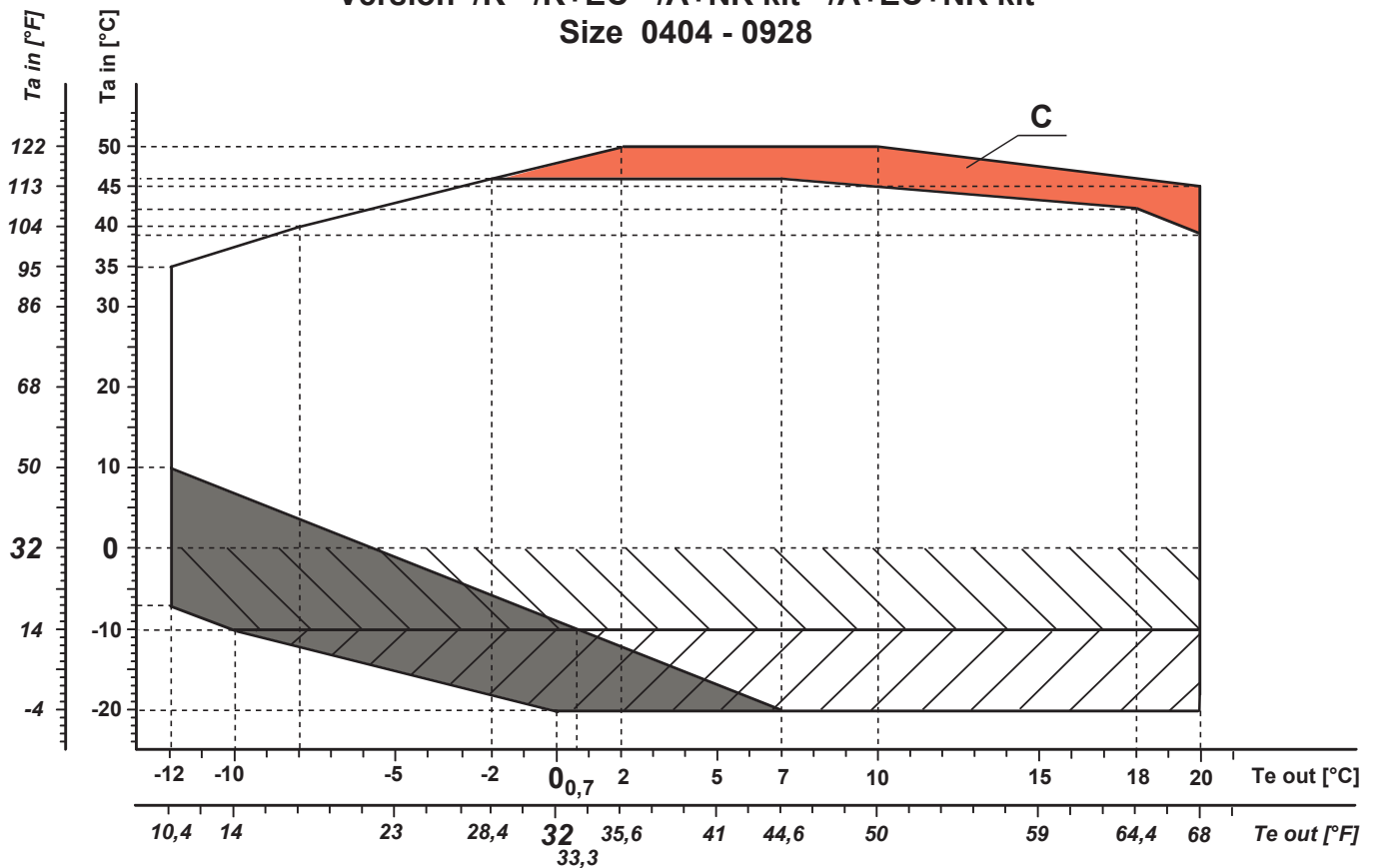



$T_{a\ in}$ Outdoor air temperature [°C]
 $T_{e\ out}$ Evaporator outlet temperature [°C]

 - Version STD

 - EC fans (code 808).

 - Part load operation

 - Antifreeze heaters on pipes, pumps* and buffer tank* (code 2432 o 2433).
(* if present)

 - Operation between -10°C and -20°C of outdoor air temperature is allowed for wind protected installations
(wind speed lower than 2 m/s - 6,56 ft/s)

 - Extra insulation on heat exchangers, pipes, pumps* and buffer tank* (RFQ),
- Extra antifreeze heaters on heat exchangers, pipes, pumps* and buffer tank* (RFQ),
(* if present)

NOTES:

For the temperature limits of each size please refer to the selection software ElcaWorld
(the diagram over 40°C could vary according to the size and the version of the selected unit).

RFQ: Request for quotation

OPERATING LIMITS

Version /A - /A+EC Size 0404 - 0928

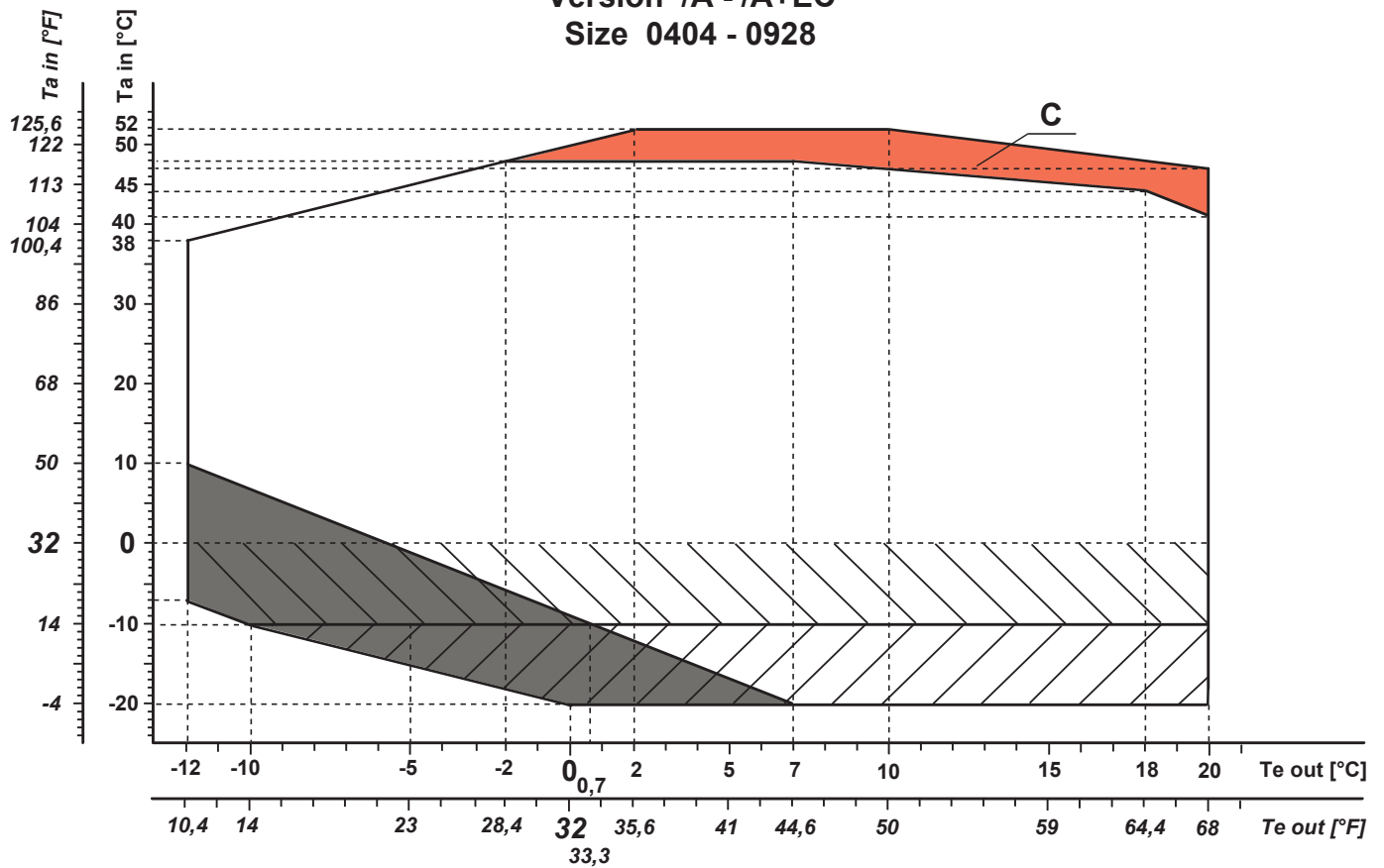

Ta in Outdoor air temperature [°C]
Te out Evaporator outlet temperature [°C]

- Version STD

- EC fans (code 808).

- Part load operation

- Antifreeze heaters on pipes, pumps* and buffer tank* (code 2432 o 2433).
 (* if present)

- Operation between -10°C and -20°C of outdoor air temperature is allowed for wind protected installations
 (wind speed lower than 2 m/s - 6,56 ft/s)

- Extra insulation on heat exchangers, pipes, pumps* and buffer tank* (RFQ),
 - Extra antifreeze heaters on heat exchangers, pipes, pumps* and buffer tank* (RFQ),
 (* if present)

NOTES:

For the temperature limits of each size please refer to the selection software ElcaWorld
 (the diagram over 40°C could vary according to the size and the version of the selected unit).
 RFQ: Request for quotation

OPERATING LIMITS

Version /K/D - /K/D+EC - /A/D+NR kit - /A/D+EC+NR kit Size 0404 - 0928

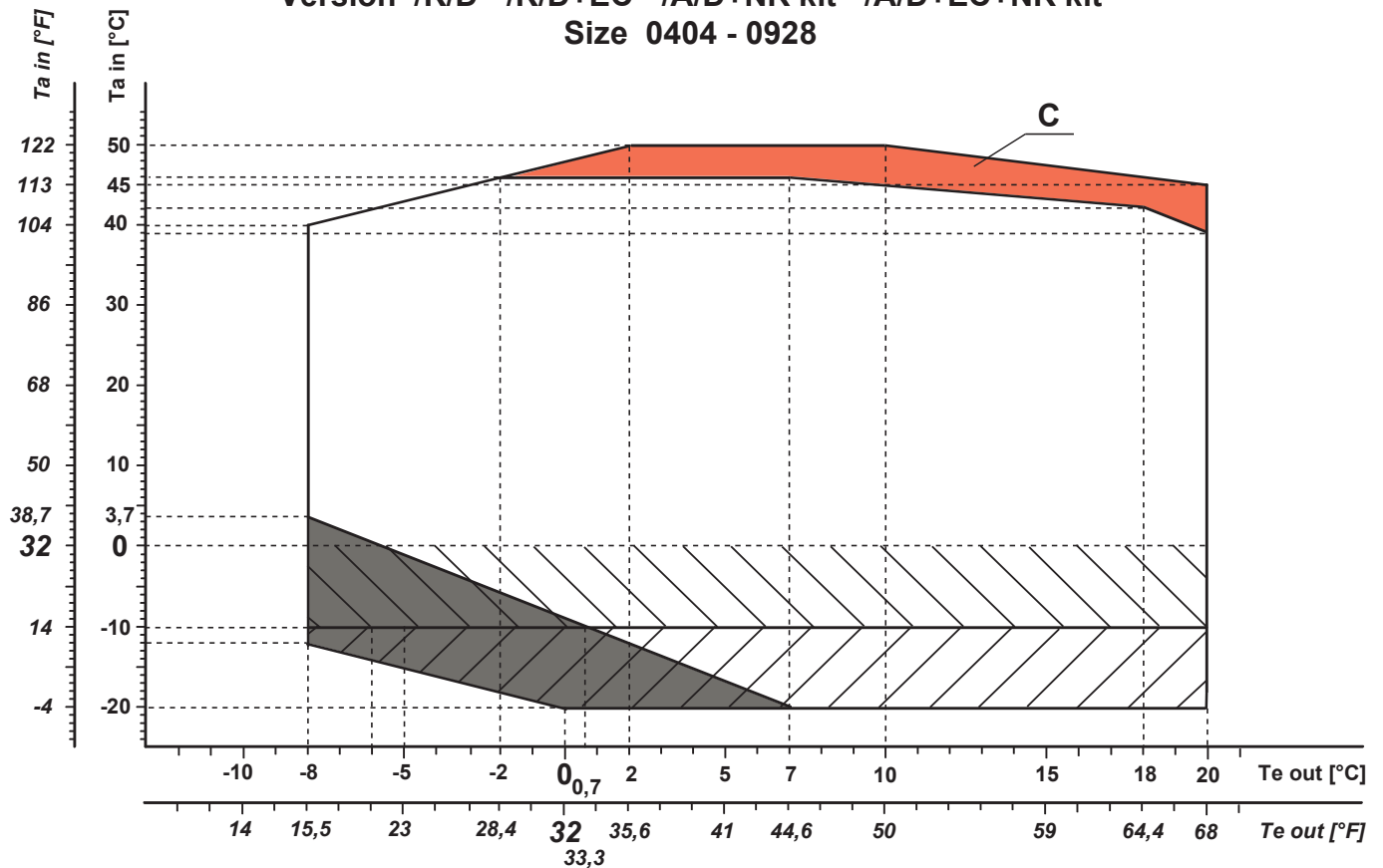



$T_{a\ in}$ Outdoor air temperature [°C]
 $T_{e\ out}$ Evaporator outlet temperature [°C]

 - Version STD

 - EC fans (code 808).

 - Part load operation

 - Antifreeze heaters on pipes, pumps* and buffer tank* (code 2432 o 2433).
 (* if present)

 - Operation between -10°C and -20°C of outdoor air temperature is allowed for wind protected installations
 (wind speed lower than 2 m/s - 6,56 ft/s)

 - Extra insulation on heat exchangers, pipes, pumps* and buffer tank* (RFQ),
 - Extra antifreeze heaters on heat exchangers, pipes, pumps* and buffer tank* (RFQ),
 (* if present)

NOTES:

For the temperature limits of each size please refer to the selection software ElcaWorld
 (the diagram over 40°C could vary according to the size and the version of the selected unit).

RFQ: Request for quotation

OPERATING LIMITS

Version /A/D - /A/D+EC
Size 0404 - 0928

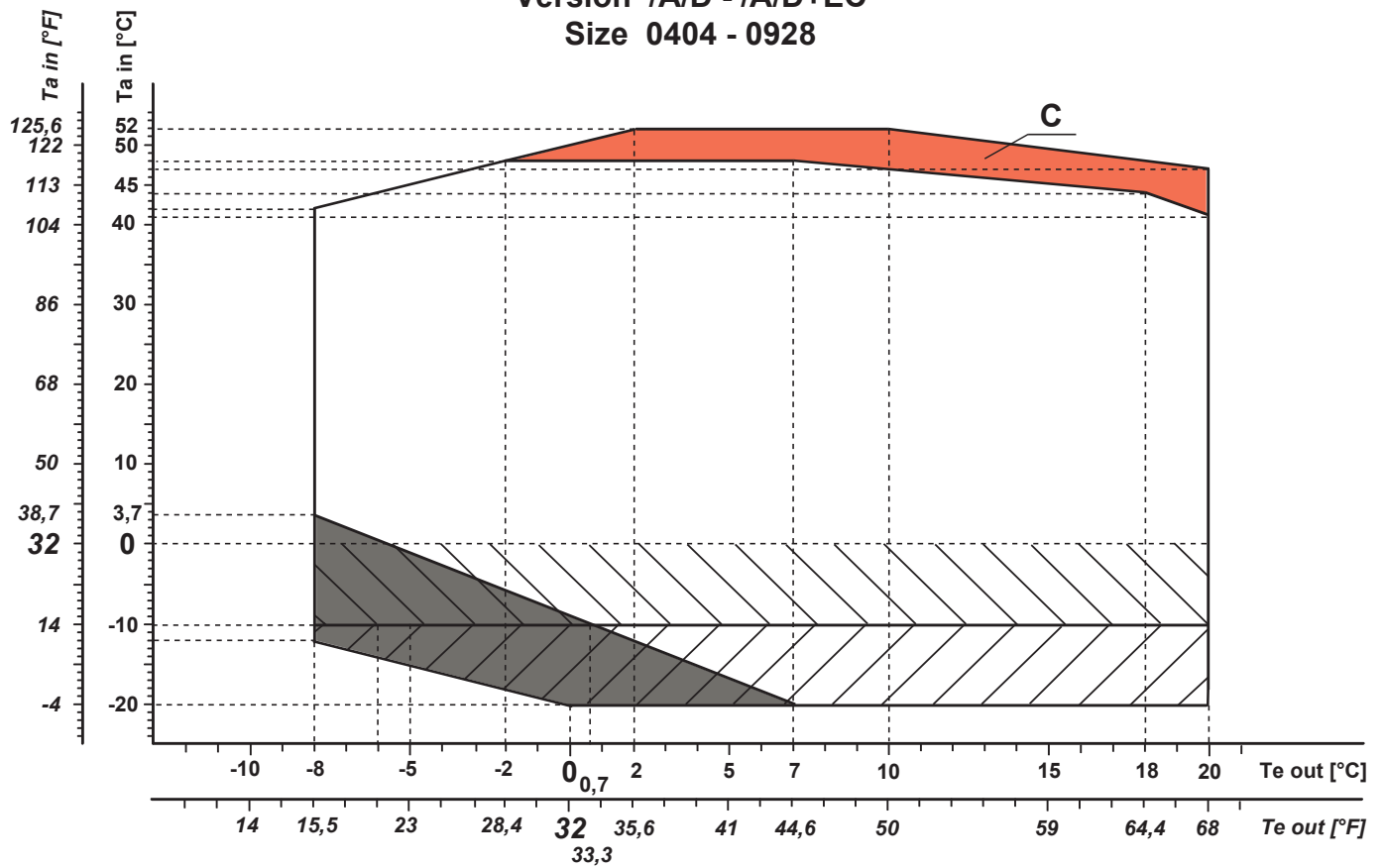

Ta in Outdoor air temperature [°C]
Te out Evaporator outlet temperature [°C]

- Version STD

- EC fans (code 808).

- Part load operation

- Antifreeze heaters on pipes, pumps* and buffer tank* (code 2432 o 2433).
(* if present)

- Operation between -10°C and -20°C of outdoor air temperature is allowed for wind protected installations (wind speed lower than 2 m/s - 6,56 ft/s)

- Extra insulation on heat exchangers, pipes, pumps* and buffer tank* (RFQ),
- Extra antifreeze heaters on heat exchangers, pipes, pumps* and buffer tank* (RFQ),
(* if present)

NOTES:

For the temperature limits of each size please refer to the selection software ElcaWorld (the diagram over 40°C could vary according to the size and the version of the selected unit).
RFQ: Request for quotation

OPERATING LIMITS

NX2-G06 0404 - 0928

SIZE	
NX2-G06 /K /0404	NX2-G06 /D /A /0928
NX2-G06 /K /0424	NX2-G06 /A /NR /0404
NX2-G06 /K /0464	NX2-G06 /A /NR /0424
NX2-G06 /K /0515	NX2-G06 /A /NR /0464
NX2-G06 /K /0576	NX2-G06 /A /NR /0515
NX2-G06 /K /0585	NX2-G06 /A /NR /0576
NX2-G06 /K /0636	NX2-G06 /A /NR /0585
NX2-G06 /K /0676	NX2-G06 /A /NR /0636
NX2-G06 /K /0706	NX2-G06 /A /NR /0676
NX2-G06 /K /0768	NX2-G06 /A /NR /0706
NX2-G06 /K /0808	NX2-G06 /A /NR /0768
NX2-G06 /K /0848	NX2-G06 /A /NR /0808
NX2-G06 /K /0898	NX2-G06 /A /NR /0848
NX2-G06 /K /0928	NX2-G06 /A /NR /0898
NX2-G06 /D /K /0404	NX2-G06 /A /NR /0928
NX2-G06 /D /K /0424	NX2-G06 /D /A /NR /0404
NX2-G06 /D /K /0464	NX2-G06 /D /A /NR /0424
NX2-G06 /D /K /0515	NX2-G06 /D /A /NR /0464
NX2-G06 /D /K /0576	NX2-G06 /D /A /NR /0515
NX2-G06 /D /K /0585	NX2-G06 /D /A /NR /0576
NX2-G06 /D /K /0636	NX2-G06 /D /A /NR /0585
NX2-G06 /D /K /0676	NX2-G06 /D /A /NR /0636
NX2-G06 /D /K /0706	NX2-G06 /D /A /NR /0676
NX2-G06 /D /K /0768	NX2-G06 /D /A /NR /0706
NX2-G06 /D /K /0808	NX2-G06 /D /A /NR /0768
NX2-G06 /D /K /0848	NX2-G06 /D /A /NR /0808
NX2-G06 /D /K /0898	NX2-G06 /D /A /NR /0848
NX2-G06 /D /K /0928	NX2-G06 /D /A /NR /0898
NX2-G06 /A /0404	NX2-G06 /D /A /NR /0928
NX2-G06 /A /0424	
NX2-G06 /A /0464	
NX2-G06 /A /0515	
NX2-G06 /A /0576	
NX2-G06 /A /0585	
NX2-G06 /A /0636	
NX2-G06 /A /0676	
NX2-G06 /A /0706	
NX2-G06 /A /0768	
NX2-G06 /A /0808	
NX2-G06 /A /0848	
NX2-G06 /A /0898	
NX2-G06 /A /0928	
NX2-G06 /D /A /0404	
NX2-G06 /D /A /0424	
NX2-G06 /D /A /0464	
NX2-G06 /D /A /0515	
NX2-G06 /D /A /0576	
NX2-G06 /D /A /0585	
NX2-G06 /D /A /0636	
NX2-G06 /D /A /0676	
NX2-G06 /D /A /0706	
NX2-G06 /D /A /0768	
NX2-G06 /D /A /0808	
NX2-G06 /D /A /0848	
NX2-G06 /D /A /0898	

7.2 ETHYLENE GLYCOL MIXTURE

Ethylene glycol and water mixture, used as a heat-conveying fluid, cause a variation in unit performance. For correct data, use the factors indicated in the following tabel.

	Freezing point (°C)							
	0	-5	-10	-15	-20	-25	-30	-35
	Ethylene glycol percentage by weight							
	0%	12%	20%	30%	35%	40%	45%	50%
cPf	1	0,985	0,98	0,974	0,97	0,965	0,964	0,96
cQ	1	1,02	1,04	1,075	1,11	1,14	1,17	1,2
cdp	1	1,07	1,11	1,18	1,22	1,24	1,27	1,3

cPf: cooling power correction factor
 cQ: flow correction factor
 cdp: pressure drop correction factor

For data concerning other kind of anti-freeze solutions (e.g, propylene glycol) please contact our Sale Department.

7.3 FOULING FACTORS

Performances are based on clean condition of tubes (fouling factor = 1). For different fouling values, performance should be adjusted using the correction factors shown in the following table.

SERIES	FOULING FACTORS	EVAPORATOR			CONDENSER/RECOVERY			DESUPERHEATER
	ff (m ² °CW)	F1	FK1	KE [°C]	F2	FK2	KC [°C]	R3
VARIOUS	0	1,000	1,000	0,0	1,000	1,000	0,0	1,000
VARIOUS	1,80 x 10 ⁻⁵	1,000	1,000	0,0	1,000	1,000	0,0	1,000
VARIOUS	4,40 x 10 ⁻⁵	1,000	1,000	0,0	0,990	1,030	1,0	0,990
VARIOUS	8,80 x 10 ⁻⁵	0,960	0,990	0,7	0,980	1,040	1,5	0,980
VARIOUS	13,20 x 10 ⁻⁵	0,944	0,985	1,0	0,964	1,050	2,3	0,964
VARIOUS	17,20 x 10 ⁻⁵	0,930	0,980	1,5	0,950	1,060	3,0	0,950

ff: fouling factors
 F1 - F2: potential correction factors
 FK1 - FK2: compressor power input correction factors
 R3: capacity correction factors
 KE: minimum evaporator outlet temperature increase
 KC: maximum condenser outlet temperature decrease

8.1 HYDRAULIC DATA

[SI System]

Water flow and pressure drop

Water flow in the plant (side) exchanger is given by:

$$Q = P / (4,186 \times Dt)$$

Q: water flow (l/s)

Dt: difference between inlet and outlet water temp. (°C)

P: heat exchanger capacity (kW)

Pressure drop is given by:

$$Dp = K \times (3,6 \times Q)^2 / 1000$$

Q: water flow (l/s)

Dp: pressure drop (kPa)

K: unit size ratio

SIZE	Power supply V/ph/Hz	HEAT EXCHANGER USER SIDE					HEAT RECOVERY EX. USER SIDE			
		K	Q min l/s	Q max l/s	C.A.S. l	C.a. min l	K	Q min l/s	Q max l/s	C.A.S. l
NX2-G06 /K /0404	400/3/50	14,5	10,58	27,58	79,0	950	-	-	-	-
NX2-G06 /K /0424	400/3/50	10,3	11,31	26,72	67,0	1000	-	-	-	-
NX2-G06 /K /0464	400/3/50	10,3	12,33	29,92	67,0	1090	-	-	-	-
NX2-G06 /K /0515	400/3/50	7,80	13,67	32,83	83,0	1460	-	-	-	-
NX2-G06 /K /0576	400/3/50	7,80	14,97	35,31	83,0	1610	-	-	-	-
NX2-G06 /K /0585	400/3/50	4,80	15,69	38,28	128	1640	-	-	-	-
NX2-G06 /K /0636	400/3/50	4,80	17,00	40,36	128	1790	-	-	-	-
NX2-G06 /K /0676	400/3/50	4,10	18,03	43,17	116	1910	-	-	-	-
NX2-G06 /K /0706	400/3/50	4,10	18,97	44,86	116	1970	-	-	-	-
NX2-G06 /K /0768	400/3/50	3,70	19,86	51,72	169	2160	-	-	-	-
NX2-G06 /K /0808	400/3/50	3,70	21,14	51,72	169	2280	-	-	-	-
NX2-G06 /K /0848	400/3/50	2,50	22,67	56,67	157	2400	-	-	-	-
NX2-G06 /K /0898	400/3/50	2,50	23,72	56,67	157	2500	-	-	-	-
NX2-G06 /K /0928	400/3/50	2,50	24,69	60,36	157	2600	-	-	-	-
NX2-G06 /D /K /0404	400/3/50	14,5	10,58	27,58	79,0	950	117	-	6,000	2,21
NX2-G06 /D /K /0424	400/3/50	10,3	11,31	26,72	67,0	1000	101	-	6,306	2,52
NX2-G06 /D /K /0464	400/3/50	10,3	12,33	29,92	67,0	1090	101	-	7,250	2,52
NX2-G06 /D /K /0515	400/3/50	7,80	13,67	32,83	83,0	1460	79,0	-	7,806	2,84
NX2-G06 /D /K /0576	400/3/50	7,80	14,97	35,31	83,0	1610	73,0	-	8,306	3,15
NX2-G06 /D /K /0585	400/3/50	4,80	15,69	38,28	128	1640	62,0	-	8,944	3,15
NX2-G06 /D /K /0636	400/3/50	4,80	17,00	40,36	128	1790	57,0	-	9,472	3,47
NX2-G06 /D /K /0676	400/3/50	4,10	18,03	43,17	116	1910	57,0	-	10,44	3,78
NX2-G06 /D /K /0706	400/3/50	4,10	18,97	44,86	116	1970	57,0	-	10,58	3,78
NX2-G06 /D /K /0768	400/3/50	3,70	19,86	51,72	169	2160	44,0	-	11,19	3,78
NX2-G06 /D /K /0808	400/3/50	3,70	21,14	51,72	169	2280	33,0	-	12,00	4,41
NX2-G06 /D /K /0848	400/3/50	2,50	22,67	56,67	157	2400	31,0	-	12,61	5,04
NX2-G06 /D /K /0898	400/3/50	2,50	23,72	56,67	157	2500	31,0	-	13,61	5,04
NX2-G06 /D /K /0928	400/3/50	2,50	24,69	60,36	157	2600	31,0	-	14,47	5,04
NX2-G06 /A /0404	400/3/50	14,5	10,58	27,58	79,0	950	-	-	-	-
NX2-G06 /A /0424	400/3/50	10,3	11,31	26,72	67,0	1000	-	-	-	-
NX2-G06 /A /0464	400/3/50	10,3	12,33	29,92	67,0	1090	-	-	-	-
NX2-G06 /A /0515	400/3/50	7,80	13,67	32,83	83,0	1460	-	-	-	-
NX2-G06 /A /0576	400/3/50	7,80	14,97	35,31	83,0	1610	-	-	-	-
NX2-G06 /A /0585	400/3/50	4,80	15,69	38,28	128	1640	-	-	-	-
NX2-G06 /A /0636	400/3/50	4,80	17,00	40,36	128	1790	-	-	-	-
NX2-G06 /A /0676	400/3/50	4,10	18,03	43,17	116	1910	-	-	-	-
NX2-G06 /A /0706	400/3/50	4,10	18,97	44,86	116	1970	-	-	-	-
NX2-G06 /A /0768	400/3/50	3,70	19,86	51,72	169	2160	-	-	-	-
NX2-G06 /A /0808	400/3/50	3,70	21,14	51,72	169	2280	-	-	-	-
NX2-G06 /A /0848	400/3/50	2,50	22,67	56,67	157	2400	-	-	-	-
NX2-G06 /A /0898	400/3/50	2,50	23,72	56,67	157	2500	-	-	-	-

Q min: minimum water flow admitted to the heat exchanger
 Q max: maximum water flow admitted to the heat exchanger
 C.a. min: minimum water content admitted in the plant
 C.A.S.: Exchanger water content

HYDRAULIC DATA

[SI System]

SIZE	Power supply V/ph/Hz	HEAT EXCHANGER USER SIDE					HEAT RECOVERY EX. USER SIDE			
		K	Q min l/s	Q max l/s	C.A.S. l	C.a. min l	K	Q min l/s	Q max l/s	C.A.S. l
NX2-G06 /A /0928	400/3/50	2,50	24,69	60,36	157	2600	-	-	-	-
NX2-G06 /D /A /0404	400/3/50	14,5	10,58	27,58	79,0	950	117	-	6,000	2,21
NX2-G06 /D /A /0424	400/3/50	10,3	11,31	26,72	67,0	1000	101	-	6,306	2,52
NX2-G06 /D /A /0464	400/3/50	10,3	12,33	29,92	67,0	1090	101	-	7,250	2,52
NX2-G06 /D /A /0515	400/3/50	7,80	13,67	32,83	83,0	1460	79,0	-	7,806	2,84
NX2-G06 /D /A /0576	400/3/50	7,80	14,97	35,31	83,0	1610	73,0	-	8,306	3,15
NX2-G06 /D /A /0585	400/3/50	4,80	15,69	38,28	128	1640	62,0	-	8,944	3,15
NX2-G06 /D /A /0636	400/3/50	4,80	17,00	40,36	128	1790	57,0	-	9,472	3,47
NX2-G06 /D /A /0676	400/3/50	4,10	18,03	43,17	116	1910	57,0	-	10,44	3,78
NX2-G06 /D /A /0706	400/3/50	4,10	18,97	44,86	116	1970	57,0	-	10,58	3,78
NX2-G06 /D /A /0768	400/3/50	3,70	19,86	51,72	169	2160	44,0	-	11,19	3,78
NX2-G06 /D /A /0808	400/3/50	3,70	21,14	51,72	169	2280	33,0	-	12,00	4,41
NX2-G06 /D /A /0848	400/3/50	2,50	22,67	56,67	157	2400	31,0	-	12,61	5,04
NX2-G06 /D /A /0898	400/3/50	2,50	23,72	56,67	157	2500	31,0	-	13,61	5,04
NX2-G06 /D /A /0928	400/3/50	2,50	24,69	60,36	157	2600	31,0	-	14,47	5,04
NX2-G06 /A /NR /0404	400/3/50	14,5	10,58	27,58	79,0	950	-	-	-	-
NX2-G06 /A /NR /0424	400/3/50	10,3	11,31	26,72	67,0	1000	-	-	-	-
NX2-G06 /A /NR /0464	400/3/50	10,3	12,33	29,92	67,0	1090	-	-	-	-
NX2-G06 /A /NR /0515	400/3/50	7,80	13,67	32,83	83,0	1460	-	-	-	-
NX2-G06 /A /NR /0576	400/3/50	7,80	14,97	35,31	83,0	1610	-	-	-	-
NX2-G06 /A /NR /0585	400/3/50	4,80	15,69	38,28	128	1640	-	-	-	-
NX2-G06 /A /NR /0636	400/3/50	4,80	17,00	40,36	128	1790	-	-	-	-
NX2-G06 /A /NR /0676	400/3/50	4,10	18,03	43,17	116	1910	-	-	-	-
NX2-G06 /A /NR /0706	400/3/50	4,10	18,97	44,86	116	1970	-	-	-	-
NX2-G06 /A /NR /0768	400/3/50	3,70	19,86	51,72	169	2160	-	-	-	-
NX2-G06 /A /NR /0808	400/3/50	3,70	21,14	51,72	169	2280	-	-	-	-
NX2-G06 /A /NR /0848	400/3/50	2,50	22,67	56,67	157	2400	-	-	-	-
NX2-G06 /A /NR /0898	400/3/50	2,50	23,72	56,67	157	2500	-	-	-	-
NX2-G06 /A /NR /0928	400/3/50	2,50	24,69	60,36	157	2600	-	-	-	-
NX2-G06 /D /A /NR /0404	400/3/50	14,5	10,58	27,58	79,0	950	117	-	6,000	2,21
NX2-G06 /D /A /NR /0424	400/3/50	10,3	11,31	26,72	67,0	1000	101	-	6,306	2,52
NX2-G06 /D /A /NR /0464	400/3/50	10,3	12,33	29,92	67,0	1090	101	-	7,250	2,52
NX2-G06 /D /A /NR /0515	400/3/50	7,80	13,67	32,83	83,0	1460	79,0	-	7,806	2,84
NX2-G06 /D /A /NR /0576	400/3/50	7,80	14,97	35,31	83,0	1610	73,0	-	8,306	3,15
NX2-G06 /D /A /NR /0585	400/3/50	4,80	15,69	38,28	128	1640	62,0	-	8,944	3,15
NX2-G06 /D /A /NR /0636	400/3/50	4,80	17,00	40,36	128	1790	57,0	-	9,472	3,47
NX2-G06 /D /A /NR /0676	400/3/50	4,10	18,03	43,17	116	1910	57,0	-	10,44	3,78
NX2-G06 /D /A /NR /0706	400/3/50	4,10	18,97	44,86	116	1970	57,0	-	10,58	3,78
NX2-G06 /D /A /NR /0768	400/3/50	3,70	19,86	51,72	169	2160	44,0	-	11,19	3,78
NX2-G06 /D /A /NR /0808	400/3/50	3,70	21,14	51,72	169	2280	33,0	-	12,00	4,41
NX2-G06 /D /A /NR /0848	400/3/50	2,50	22,67	56,67	157	2400	31,0	-	12,61	5,04
NX2-G06 /D /A /NR /0898	400/3/50	2,50	23,72	56,67	157	2500	31,0	-	13,61	5,04
NX2-G06 /D /A /NR /0928	400/3/50	2,50	24,69	60,36	157	2600	31,0	-	14,47	5,04

Q min: minimum water flow admitted to the heat exchanger
 Q max: maximum water flow admitted to the heat exchanger
 C.a. min: minimum water content admitted in the plant
 C.A.S.: Exchanger water content

9.1 ELECTRICAL DATA

NX2-G06 / K

[SI System]

SIZE	Power supply V/ph/Hz	Maximum values								
		n	Compressor			Fans (1)		Total (1)(2)		
			F.L.I. [kW]	F.L.A. [A]	L.R.A. [A]	F.L.I. [kW]	F.L.A. [A]	F.L.I. [kW]	F.L.A. [A]	S.A. [A]
0404	400/3/50	4	3x34,5+1x42	3x55,1+1x68,4	3x326+1x298	1,900	4	156,9	257	515
0424	400/3/50	4	2x34,5+2x42	2x55,1+2x68,4	2x326+2x298	1,900	4	164,4	270	528
0464	400/3/50	4	4x42	4x68,4	4x298	1,900	4	179,4	297	527
0515	400/3/50	5	3x34,5+2x42	3x55,1+2x68,4	3x326+2x298	1,900	4	200,8	329	587
0576	400/3/50	6	6x34,5	6x55,1	6x326	1,900	4	222,2	362	633
0585	400/3/50	5	5x42	5x68,4	5x298	1,900	4	225,2	373	603
0636	400/3/50	6	3x34,5+3x42	3x55,1+3x68,4	3x326+3x298	1,900	4	246,6	406	663
0676	400/3/50	6	1x34,5+5x42	1x55,1+5x68,4	1x326+5x298	1,900	4	261,6	432	690
0706	400/3/50	6	6x42	6x68,4	6x298	1,900	4	271,0	449	679
0768	400/3/50	8	8x34,5	8x55,1	8x326	1,900	4	298,8	488	759
0808	400/3/50	8	6x34,5+2x42	6x55,1+2x68,4	6x326+2x298	1,900	4	313,8	514	772
0848	400/3/50	8	4x34,5+4x42	4x55,1+4x68,4	4x326+4x298	1,900	4	328,8	541	798
0898	400/3/50	8	2x34,5+6x42	2x55,1+6x68,4	2x326+6x298	1,900	4	343,8	567	825
0928	400/3/50	8	8x42	8x68,4	8x298	1,900	4	358,8	594	824

F.L.I.: Full load power

F.L.A.: Full load current

L.R.A.: Locked rotor amperes for single compressor

S.A.: Inrush current

(1) Values calculated referring to the version with the maximum number of fans working at the max absorbed current

(1)(2) Safety values to be considered when cabling the unit for power supply and line-protections

Data valid for standard units without any additional option.

Plant (side) cooling exchanger water (in/out) 12,00°C/7,00°C; Source (side) heat exchanger air (in) 35,0°C.

Voltage tolerance: 10%

Maximum voltage unbalance: 3%

Give the typical operating conditions of units designed for outdoor installation, which can be associated (according to reference document IEC 60721) to the following classes:

- climatic conditions class 4K4H: air temperature range from -20 up to 55°C (*), relative humidity range from 4 up to 100%, with possible precipitations, at air pressure from 70 and 106 kPa and a maximum solar radiation of 1120 W/m²

- special climatic conditions negligible

- biological conditions class 4B1 and 4C2: locations in a generic urban area

- mechanically active substances class 4S2: locations in areas with sand or dust representative of urban areas

- mechanical conditions class 4M1: locations protected from significant vibrations or shocks

The required protection level for safe operation, according to reference document IEC 60529, is IP43XW (protection against access, to the most critical unit's parts, of external devices with diameter larger than 1 mm and rain).

The unit can be considered IP44XW protected, i.e. protected against access of external devices (with diameter larger than 1 mm) and water in general.

(*) for the unit's operating limits, see "selection limits" section

ELECTRICAL DATA

NX2-G06 / A

[SI System]

SIZE	Power supply V/ph/Hz	Maximum values								
		n	Compressor			Fans (1)		Total (1)(2)		
			F.L.I. [kW]	F.L.A. [A]	L.R.A. [A]	F.L.I. [kW]	F.L.A. [A]	F.L.I. [kW]	F.L.A. [A]	S.A. [A]
0404	400/3/50	4	3x34,5+1x42	3x55,1+1x68,4	3x326+1x298	1,900	4	160,7	265	523
0424	400/3/50	4	2x34,5+2x42	2x55,1+2x68,4	2x326+2x298	1,900	4	168,2	278	536
0464	400/3/50	4	4x42	4x68,4	4x298	1,900	4	183,2	305	534
0515	400/3/50	5	3x34,5+2x42	3x55,1+2x68,4	3x326+2x298	1,900	4	204,6	337	595
0576	400/3/50	6	6x34,5	6x55,1	6x326	1,900	4	226,0	370	641
0585	400/3/50	5	5x42	5x68,4	5x298	1,900	4	229,0	381	611
0636	400/3/50	6	3x34,5+3x42	3x55,1+3x68,4	3x326+3x298	1,900	4	250,4	413	671
0676	400/3/50	6	1x34,5+5x42	1x55,1+5x68,4	1x326+5x298	1,900	4	267,3	444	702
0706	400/3/50	6	6x42	6x68,4	6x298	1,900	4	274,8	457	687
0768	400/3/50	8	8x34,5	8x55,1	8x326	1,900	4	306,4	503	774
0808	400/3/50	8	6x34,5+2x42	6x55,1+2x68,4	6x326+2x298	1,900	4	321,4	530	787
0848	400/3/50	8	4x34,5+4x42	4x55,1+4x68,4	4x326+4x298	1,900	4	336,4	556	814
0898	400/3/50	8	2x34,5+6x42	2x55,1+6x68,4	2x326+6x298	1,900	4	351,4	583	841
0928	400/3/50	8	8x42	8x68,4	8x298	1,900	4	366,4	610	839

F.L.I.: Full load power

F.L.A.: Full load current

L.R.A.: Locked rotor amperes for single compressor

S.A.: Inrush current

(1) Values calculated referring to the version with the maximum number of fans working at the max absorbed current

(1)(2) Safety values to be considered when cabling the unit for power supply and line-protections

Data valid for standard units without any additional option.

Plant (side) cooling exchanger water (in/out) 12,00°C/7,00°C; Source (side) heat exchanger air (in) 35,0°C.

Voltage tolerance: 10%

Maximum voltage unbalance: 3%

Give the typical operating conditions of units designed for outdoor installation, which can be associated (according to reference document IEC 60721) to the following classes:

- climatic conditions class 4K4H: air temperature range from -20 up to 55°C (*), relative humidity range from 4 up to 100%, with possible precipitations, at air pressure from 70 and 106 kPa and a maximum solar radiation of 1120 W/m2

- special climatic conditions negligible

- biological conditions class 4B1 and 4C2: locations in a generic urban area

- mechanically active substances class 4S2: locations in areas with sand or dust representative of urban areas

- mechanical conditions class 4M1: locations protected from significant vibrations or shocks

The required protection level for safe operation, according to reference document IEC 60529, is IP43XW (protection against access, to the most critical unit's parts, of external devices with diameter larger than 1 mm and rain).

The unit can be considered IP44XW protected, i.e. protected against access of external devices (with diameter larger than 1 mm) and water in general.

(*) for the unit's operating limits, see "selection limits" section

ELECTRICAL DATA

NX2-G06 / A + NR kit

[SI System]

SIZE	Power supply V/ph/Hz	Maximum values								
		n	Compressor			Fans (1)		Total (1)(2)		
			F.L.I. [kW]	F.L.A. [A]	L.R.A. [A]	F.L.I. [kW]	F.L.A. [A]	F.L.I. [kW]	F.L.A. [A]	S.A. [A]
0404	400/3/50	4	3x34,5+1x42	3x55,1+1x68,4	3x326+1x298	1,200	2	155,1	251	509
0424	400/3/50	4	2x34,5+2x42	2x55,1+2x68,4	2x326+2x298	1,200	2	162,6	265	522
0464	400/3/50	4	4x42	4x68,4	4x298	1,200	2	177,6	291	521
0515	400/3/50	5	3x34,5+2x42	3x55,1+2x68,4	3x326+2x298	1,200	2	198,3	322	580
0576	400/3/50	6	6x34,5	6x55,1	6x326	1,200	2	219,0	353	624
0585	400/3/50	5	5x42	5x68,4	5x298	1,200	2	222,0	364	594
0636	400/3/50	6	3x34,5+3x42	3x55,1+3x68,4	3x326+3x298	1,200	2	242,7	395	652
0676	400/3/50	6	1x34,5+5x42	1x55,1+5x68,4	1x326+5x298	1,200	2	258,9	424	681
0706	400/3/50	6	6x42	6x68,4	6x298	1,200	2	266,4	437	666
0768	400/3/50	8	8x34,5	8x55,1	8x326	1,200	2	295,2	476	747
0808	400/3/50	8	6x34,5+2x42	6x55,1+2x68,4	6x326+2x298	1,200	2	310,2	503	760
0848	400/3/50	8	4x34,5+4x42	4x55,1+4x68,4	4x326+4x298	1,200	2	325,2	529	787
0898	400/3/50	8	2x34,5+6x42	2x55,1+6x68,4	2x326+6x298	1,200	2	340,2	556	813
0928	400/3/50	8	8x42	8x68,4	8x298	1,200	2	355,2	582	812

F.L.I.: Full load power

F.L.A.: Full load current

L.R.A.: Locked rotor amperes for single compressor

S.A.: Inrush current

(1) Values calculated referring to the version with the maximum number of fans working at the max absorbed current

(1)(2) Safety values to be considered when cabling the unit for power supply and line-protections

Data valid for standard units without any additional option.

Plant (side) cooling exchanger water (in/out) 12,00°C/7,00°C; Source (side) heat exchanger air (in) 35,0°C.

Voltage tolerance: 10%

Maximum voltage unbalance: 3%

Give the typical operating conditions of units designed for outdoor installation, which can be associated (according to reference document IEC 60721) to the following classes:

- climatic conditions class 4K4H: air temperature range from -20 up to 55°C (*), relative humidity range from 4 up to 100%, with possible precipitations, at air pressure from 70 and 106 kPa and a maximum solar radiation of 1120 W/m2

- special climatic conditions negligible

- biological conditions class 4B1 and 4C2: locations in a generic urban area

- mechanically active substances class 4S2: locations in areas with sand or dust representative of urban areas

- mechanical conditions class 4M1: locations protected from significant vibrations or shocks

The required protection level for safe operation, according to reference document IEC 60529, is IP43XW (protection against access, to the most critical unit's parts, of external devices with diameter larger than 1 mm and rain).

The unit can be considered IP44XW protected, i.e. protected against access of external devices (with diameter larger than 1 mm) and water in general.

(*) for the unit's operating limits, see "selection limits" section

ELECTRICAL DATA

MAXIMUM CABLES/BARS SECTION CONNECTED TO MAIN SWITCH AND SHORT TIME CURRENT STANDARD UNITS

Unit size (all versions)	Main switch type (category AC23A/B)	Cable section	Bar dimensions	Maximum back-up fuse rating	ICW (0,3s) Short time current rms	Further technical data
		∅ [mm ²]	[mm]	[A]	[kA]	
0404	SIRCO 400A	min 185 max 240	max 2x40x5	400	25	https://www.socomec.com/files/live/sites/systemsite/files/SCP/pdf_catalogue/GB/cat_sircosircoac_en.pdf
0424	SIRCO 400A	min 185 max 240	max 2x40x5	400	25	
0464	SIRCO 400A	min 185 max 240	max 2x40x5	400	25	
0515	SIRCO 630A	min 2 x 150 max 2 x 300	min 2x30x5 max 2x50x5	630	25	
0576	SIRCO 630A	min 2 x 150 max 2 x 300	min 2x30x5 max 2x50x5	630	25	
0585	SIRCO 630A	min 2 x 150 max 2 x 300	min 2x30x5 max 2x50x5	630	25	
0636	SIRCO 630A	min 2 x 150 max 2 x 300	min 2x30x5 max 2x50x5	630	25	
0676	SIRCO 630A	min 2 x 150 max 2 x 300	min 2x30x5 max 2x50x5	630	25	
0706	SIRCO 630A	min 2 x 150 max 2 x 300	min 2x30x5 max 2x50x5	630	25	
0768	SIRCO 800A	min 2 x 185 max 2 x 300	min 2x40x5 max 2x63x5	800	27	
0808	SIRCO 800A	min 2 x 185 max 2 x 300	min 2x40x5 max 2x63x5	800	27	
0848	SIRCO 800A	min 2 x 185 max 2 x 300	min 2x40x5 max 2x63x5	800	27	
0898	SIRCO 800A	min 2 x 185 max 2 x 300	min 2x40x5 max 2x63x5	800	27	
0928	SIRCO 800A	min 2 x 185 max 2 x 300	min 2x40x5 max 2x63x5	800	27	

Electrical data valid for standard units without any additional option

Voltage tolerance: 10%

Maximum voltage unbalance: 3%

10.1 FULL LOAD SOUND LEVEL

NX2-G06 / K

SOUND POWER LEVEL IN COOLING									
SIZE	Octave band [Hz]								Total sound level dB(A)
	63	125	250	500	1000	2000	4000	8000	
	Sound power level dB								
0404	97	96	93	91	90	85	79	74	94
0424	97	96	93	91	90	85	79	74	94
0464	97	96	93	91	90	85	79	74	94
0515	97	96	93	91	90	85	79	74	94
0576	98	97	94	92	91	86	80	74	95
0585	98	97	94	92	91	86	80	74	95
0636	98	97	94	92	91	86	80	74	95
0676	98	97	94	92	91	86	80	74	95
0706	98	97	95	93	92	87	81	75	96
0768	98	97	95	93	92	87	81	75	96
0808	98	97	95	93	92	87	81	75	96
0848	99	98	96	94	93	88	82	76	97
0898	99	98	96	94	93	88	82	76	97
0928	99	98	96	94	93	88	82	76	97

Working conditions

Plant (side) cooling exchanger water (in/out) 12,00°C/7,00°C; Source (side) heat exchanger air (in) 35,0°C.

Sound power on the basis of measurements taken in compliance with ISO 9614.

Such certification refers specifically to the sound Power Level in dB(A). This is therefore the only acoustic data to be considered as binding.

Sound power level in cooling, outdoors.

SOUND PRESSURE LEVEL									
SIZE	Octave band [Hz]								Total sound level dB(A)
	63	125	250	500	1000	2000	4000	8000	
	Sound pressure level dB								
0404	65	64	61	59	58	53	47	42	62
0424	65	64	61	59	58	53	47	42	62
0464	65	64	61	59	58	53	47	42	62
0515	65	64	61	59	58	53	47	42	62
0576	66	65	62	60	59	54	48	42	63
0585	66	65	62	60	59	54	48	42	63
0636	65	64	61	59	58	53	47	41	62
0676	65	64	61	59	58	53	47	41	62
0706	65	64	62	60	59	54	48	42	63
0768	65	64	62	60	59	54	48	42	63
0808	65	64	62	60	59	54	48	42	63
0848	66	65	63	61	60	55	49	43	64
0898	66	65	63	61	60	55	49	43	64
0928	66	65	63	61	60	55	49	43	64

Working conditions

Plant (side) cooling exchanger water (in/out) 12,00°C/7,00°C; Source (side) heat exchanger air (in) 35,0°C.

Average sound pressure level at 10m distance, unit in a free field on a reflective surface; non-binding value calculated from the sound power level.

SOUND POWER LEVEL IN COOLING									
SIZE	Octave band [Hz]								Total sound level dB(A)
	63	125	250	500	1000	2000	4000	8000	
	Sound power level dB								
0404	98	97	94	92	91	86	80	74	95
0424	98	97	94	92	91	86	80	74	95
0464	98	97	94	92	91	86	80	74	95
0515	98	97	94	92	91	86	80	74	95
0576	98	97	95	93	92	87	81	75	96
0585	98	97	95	93	92	87	81	75	96
0636	98	97	95	93	92	87	81	75	96
0676	99	98	96	94	93	88	82	76	97
0706	99	98	96	94	93	88	82	76	97
0768	99	98	96	94	93	88	82	76	97
0808	99	98	96	94	93	88	82	76	97
0848	99	99	97	95	94	89	83	76	98
0898	99	99	97	95	94	89	83	76	98
0928	99	99	97	95	94	89	83	76	98

Working conditions

Plant (side) cooling exchanger water (in/out) 12,00°C/7,00°C; Source (side) heat exchanger air (in) 35,0°C.

Sound power on the basis of measurements taken in compliance with ISO 9614.

Such certification refers specifically to the sound Power Level in dB(A). This is therefore the only acoustic data to be considered as binding.

Sound power level in cooling, outdoors.

SOUND PRESSURE LEVEL									
SIZE	Octave band [Hz]								Total sound level dB(A)
	63	125	250	500	1000	2000	4000	8000	
	Sound pressure level dB								
0404	66	65	62	60	59	54	48	42	63
0424	66	65	62	60	59	54	48	42	63
0464	66	65	62	60	59	54	48	42	63
0515	65	64	61	59	58	53	47	41	62
0576	65	64	62	60	59	54	48	42	63
0585	65	64	62	60	59	54	48	42	63
0636	65	64	62	60	59	54	48	42	63
0676	66	65	63	61	60	55	49	43	64
0706	66	65	63	61	60	55	49	43	64
0768	66	65	63	61	60	55	49	43	64
0808	66	65	63	61	60	55	49	43	64
0848	66	66	64	62	61	56	50	43	65
0898	66	66	64	62	61	56	50	43	65
0928	66	66	64	62	61	56	50	43	65

Working conditions

Plant (side) cooling exchanger water (in/out) 12,00°C/7,00°C; Source (side) heat exchanger air (in) 35,0°C.

Average sound pressure level at 10m distance, unit in a free field on a reflective surface; non-binding value calculated from the sound power level.

FULL LOAD SOUND LEVEL

NX2-G06 / A + NR kit

SOUND POWER LEVEL IN COOLING									
SIZE	Octave band [Hz]								Total sound level dB(A)
	63	125	250	500	1000	2000	4000	8000	
	Sound power level dB								
0404	88	87	86	84	81	76	69	63	86
0424	88	87	86	84	81	76	69	63	86
0464	89	88	87	85	82	77	70	64	87
0515	89	88	87	85	82	77	70	64	87
0576	89	88	87	85	82	77	70	64	87
0585	90	89	88	86	83	78	71	65	88
0636	90	89	88	86	83	78	71	65	88
0676	90	89	88	86	83	78	71	65	88
0706	91	90	89	87	84	79	72	66	89
0768	92	91	90	88	85	80	73	67	90
0808	92	91	90	88	85	80	73	67	90
0848	92	91	90	88	85	80	73	67	90
0898	92	91	90	88	85	80	73	67	90
0928	92	91	90	88	85	80	73	67	90

Working conditions

Plant (side) cooling exchanger water (in/out) 12,00°C/7,00°C; Source (side) heat exchanger air (in) 35,0°C.

Sound power on the basis of measurements taken in compliance with ISO 9614.

Such certification refers specifically to the sound Power Level in dB(A). This is therefore the only acoustic data to be considered as binding.

Sound power level in cooling, outdoors.

SOUND PRESSURE LEVEL									
SIZE	Octave band [Hz]								Total sound level dB(A)
	63	125	250	500	1000	2000	4000	8000	
	Sound pressure level dB								
0404	56	55	54	52	49	44	37	31	54
0424	56	55	54	52	49	44	37	31	54
0464	57	56	55	53	50	45	38	32	55
0515	56	55	54	52	49	44	37	31	54
0576	56	55	54	52	49	44	37	31	54
0585	57	56	55	53	50	45	38	32	55
0636	57	56	55	53	50	45	38	32	55
0676	57	56	55	53	50	45	38	32	55
0706	58	57	56	54	51	46	39	33	56
0768	59	58	57	55	52	47	40	34	57
0808	59	58	57	55	52	47	40	34	57
0848	59	58	57	55	52	47	40	34	57
0898	59	58	57	55	52	47	40	34	57
0928	59	58	57	55	52	47	40	34	57

Working conditions

Plant (side) cooling exchanger water (in/out) 12,00°C/7,00°C; Source (side) heat exchanger air (in) 35,0°C.

Average sound pressure level at 10m distance, unit in a free field on a reflective surface; non-binding value calculated from the sound power level.

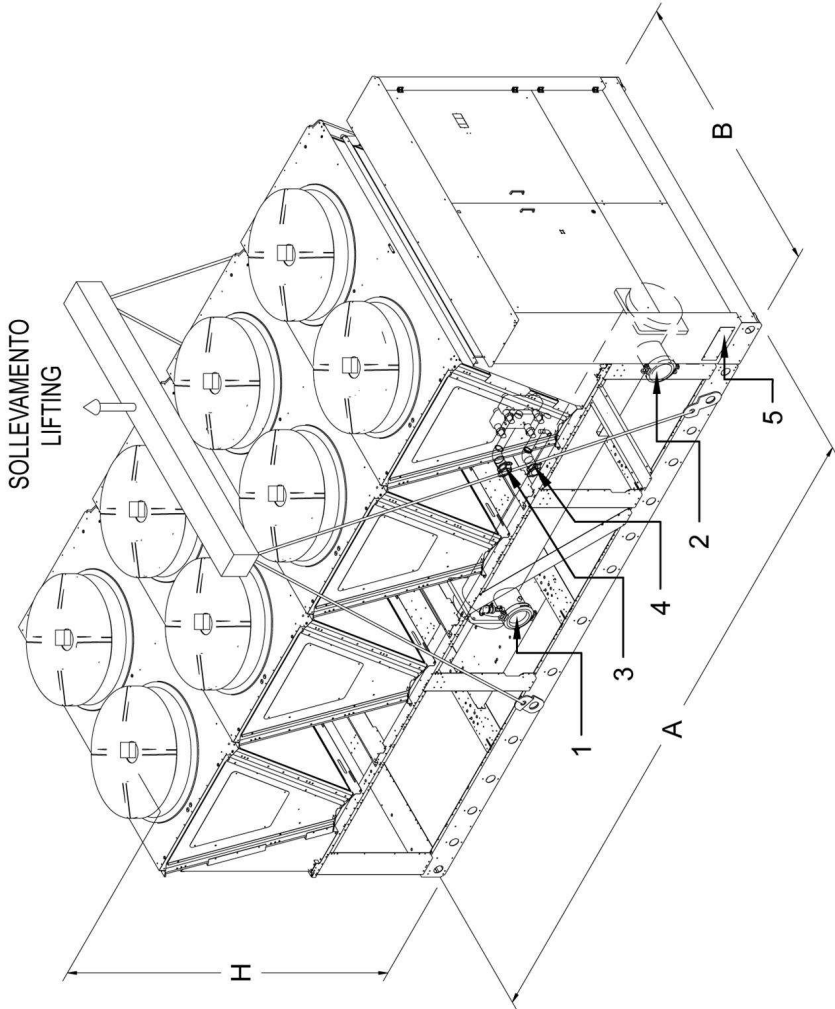

- 1 ENTRATA ACQUA EVAPORATORE
EVAPORATOR WATER INLET
- 2 USCITA ACQUA EVAPORATORE
EVAPORATOR WATER OUTLET
- 3 ENTRATA ACQUA RECUPERATORE
RECUPERATOR WATER INLET
- 4 USCITA ACQUA RECUPERATORE
RECUPERATOR WATER OUTLET
- 5 INGRESSO LINEA ELETTRICA
POWER INLET

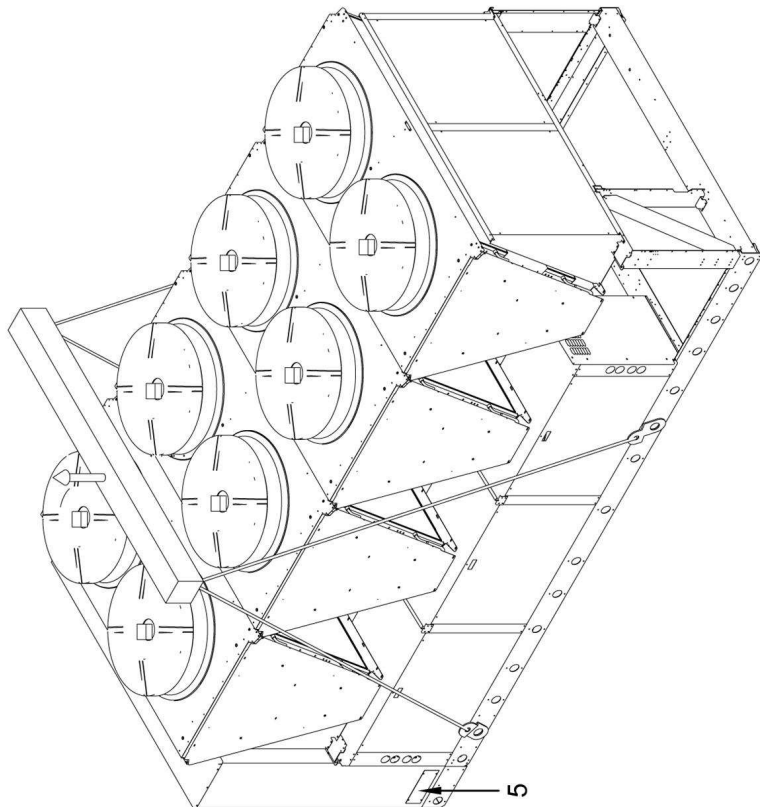

BASE D'APPOGGIO
SUPPORTING BASEMENT

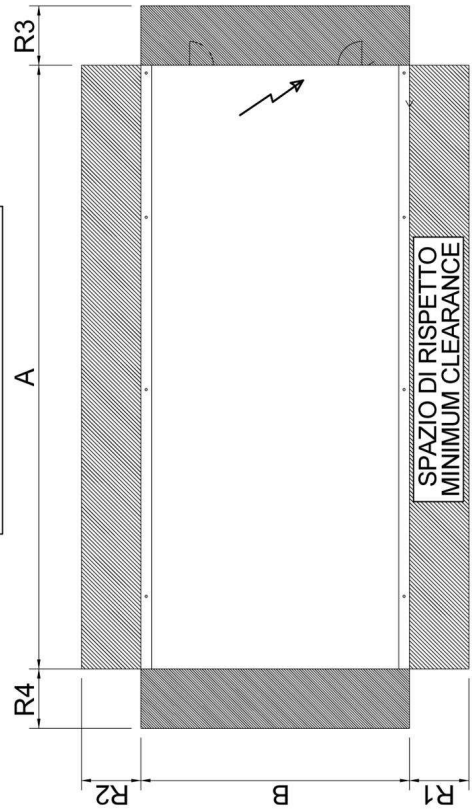

REMARKS: For installation purposes, please refer to the documentation sent after the purchase contract. This technical data should be considered as indicative. Mitsubishi Electric Hydronics & IT Cooling Systems S.p.A. may modify them at any moment. Data valid for standard units without any additional option.

DIMENSIONAL DRAWINGS

NX2-G06 0404 - 0928

[SI System]

SIZE	DIMENSIONS AND WEIGHTS				CLEARANCE				HEAT EXCHANGER USER SIDE		HEAT RECOVERY EX. USER SIDE	
	A	B	H WEIGHT		R1	R2	R3	R4	IN/OUT		IN/OUT	
	[mm]	[mm]	[mm]	[kg]	[mm]	[mm]	[mm]	[mm]	TYPE	Ø	TYPE	Ø
NX2-G06 /K /0404	3905	2260	2560	2590	2000	1500	1500	1500	A	4"	-	-
NX2-G06 /K /0424	3905	2260	2560	2620	2000	1500	1500	1500	A	4"	-	-
NX2-G06 /K /0464	3905	2260	2560	2660	2000	1500	1500	1500	A	4"	-	-
NX2-G06 /K /0515	5080	2260	2560	3190	2000	1500	1500	1500	A	5"	-	-
NX2-G06 /K /0576	5080	2260	2560	3420	2000	1500	1500	1500	A	5"	-	-
NX2-G06 /K /0585	5080	2260	2560	3500	2000	1500	1500	1500	A	5"	-	-
NX2-G06 /K /0636	6255	2260	2560	3940	2000	1500	1500	1500	A	5"	-	-
NX2-G06 /K /0676	6255	2260	2560	3980	2000	1500	1500	1500	A	5"	-	-
NX2-G06 /K /0706	6255	2260	2560	4100	2000	1500	1500	1500	A	5"	-	-
NX2-G06 /K /0768	7430	2260	2560	4970	2000	1500	1500	1500	A	6"	-	-
NX2-G06 /K /0808	7430	2260	2560	5010	2000	1500	1500	1500	A	6"	-	-
NX2-G06 /K /0848	7430	2260	2560	5080	2000	1500	1500	1500	A	6"	-	-
NX2-G06 /K /0898	7430	2260	2560	5120	2000	1500	1500	1500	A	6"	-	-
NX2-G06 /K /0928	7430	2260	2560	5150	2000	1500	1500	1500	A	6"	-	-
NX2-G06 /D /K /0404	3905	2260	2560	2590	2000	1500	1500	1500	A	4"	A	2"
NX2-G06 /D /K /0424	3905	2260	2560	2620	2000	1500	1500	1500	A	4"	A	2"
NX2-G06 /D /K /0464	3905	2260	2560	2660	2000	1500	1500	1500	A	4"	A	2"
NX2-G06 /D /K /0515	5080	2260	2560	3190	2000	1500	1500	1500	A	5"	A	2"1/2
NX2-G06 /D /K /0576	5080	2260	2560	3420	2000	1500	1500	1500	A	5"	A	2"1/2
NX2-G06 /D /K /0585	5080	2260	2560	3500	2000	1500	1500	1500	A	5"	A	2"1/2
NX2-G06 /D /K /0636	6255	2260	2560	3940	2000	1500	1500	1500	A	5"	A	2"1/2
NX2-G06 /D /K /0676	6255	2260	2560	3980	2000	1500	1500	1500	A	5"	A	2"1/2
NX2-G06 /D /K /0706	6255	2260	2560	4100	2000	1500	1500	1500	A	5"	A	2"1/2
NX2-G06 /D /K /0768	7430	2260	2560	4970	2000	1500	1500	1500	A	6"	A	2"1/2
NX2-G06 /D /K /0808	7430	2260	2560	5010	2000	1500	1500	1500	A	6"	A	2"1/2
NX2-G06 /D /K /0848	7430	2260	2560	5080	2000	1500	1500	1500	A	6"	A	2"1/2
NX2-G06 /D /K /0898	7430	2260	2560	5120	2000	1500	1500	1500	A	6"	A	2"1/2
NX2-G06 /D /K /0928	7430	2260	2560	5150	2000	1500	1500	1500	A	6"	A	2"1/2
NX2-G06 /A /0404	5080	2260	2560	2930	2000	1500	1500	1500	A	4"	-	-
NX2-G06 /A /0424	5080	2260	2560	2960	2000	1500	1500	1500	A	4"	-	-
NX2-G06 /A /0464	5080	2260	2560	3000	2000	1500	1500	1500	A	4"	-	-
NX2-G06 /A /0515	6255	2260	2560	3600	2000	1500	1500	1500	A	5"	-	-
NX2-G06 /A /0576	6255	2260	2560	3830	2000	1500	1500	1500	A	5"	-	-
NX2-G06 /A /0585	6255	2260	2560	3900	2000	1500	1500	1500	A	5"	-	-
NX2-G06 /A /0636	7430	2260	2560	4290	2000	1500	1500	1500	A	5"	-	-
NX2-G06 /A /0676	7430	2260	2560	4430	2000	1500	1500	1500	A	5"	-	-
NX2-G06 /A /0706	7430	2260	2560	4450	2000	1500	1500	1500	A	5"	-	-
NX2-G06 /A /0768	9780	2260	2560	5660	2000	1500	1500	1500	A	6"	-	-
NX2-G06 /A /0808	9780	2260	2560	5720	2000	1500	1500	1500	A	6"	-	-
NX2-G06 /A /0848	9780	2260	2560	5770	2000	1500	1500	1500	A	6"	-	-
NX2-G06 /A /0898	9780	2260	2560	5810	2000	1500	1500	1500	A	6"	-	-
NX2-G06 /A /0928	9780	2260	2560	5850	2000	1500	1500	1500	A	6"	-	-
NX2-G06 /D /A /0404	5080	2260	2560	2930	2000	1500	1500	1500	A	4"	A	2"
NX2-G06 /D /A /0424	5080	2260	2560	2960	2000	1500	1500	1500	A	4"	A	2"
NX2-G06 /D /A /0464	5080	2260	2560	3000	2000	1500	1500	1500	A	4"	A	2"
NX2-G06 /D /A /0515	6255	2260	2560	3600	2000	1500	1500	1500	A	5"	A	2"1/2
NX2-G06 /D /A /0576	6255	2260	2560	3830	2000	1500	1500	1500	A	5"	A	2"1/2
NX2-G06 /D /A /0585	6255	2260	2560	3900	2000	1500	1500	1500	A	5"	A	2"1/2
NX2-G06 /D /A /0636	7430	2260	2560	4290	2000	1500	1500	1500	A	5"	A	2"1/2
NX2-G06 /D /A /0676	7430	2260	2560	4430	2000	1500	1500	1500	A	5"	A	2"1/2
NX2-G06 /D /A /0706	7430	2260	2560	4450	2000	1500	1500	1500	A	5"	A	2"1/2
NX2-G06 /D /A /0768	9780	2260	2560	5660	2000	1500	1500	1500	A	6"	A	2"1/2

DIMENSIONAL DRAWINGS

NX2-G06 0404 - 0928

[SI System]

SIZE	DIMENSIONS AND WEIGHTS				CLEARANCE				HEAT EXCHANGER USER SIDE		HEAT RECOVERY EX. USER SIDE	
	A	B	H WEIGHT		R1	R2	R3	R4	IN/OUT		IN/OUT	
	[mm]	[mm]	[mm]	[kg]	[mm]	[mm]	[mm]	[mm]	TYPE	Ø	TYPE	Ø
NX2-G06 /D /A /0808	9780	2260	2560	5720	2000	1500	1500	1500	A	6"	A	2"1/2
NX2-G06 /D /A /0848	9780	2260	2560	5770	2000	1500	1500	1500	A	6"	A	2"1/2
NX2-G06 /D /A /0898	9780	2260	2560	5810	2000	1500	1500	1500	A	6"	A	2"1/2
NX2-G06 /D /A /0928	9780	2260	2560	5850	2000	1500	1500	1500	A	6"	A	2"1/2
NX2-G06 /A /NR /0404	5080	2260	2560	2930	2000	1500	1500	1500	A	4"	-	-
NX2-G06 /A /NR /0424	5080	2260	2560	2960	2000	1500	1500	1500	A	4"	-	-
NX2-G06 /A /NR /0464	5080	2260	2560	3000	2000	1500	1500	1500	A	4"	-	-
NX2-G06 /A /NR /0515	6255	2260	2560	3600	2000	1500	1500	1500	A	5"	-	-
NX2-G06 /A /NR /0576	6255	2260	2560	3830	2000	1500	1500	1500	A	5"	-	-
NX2-G06 /A /NR /0585	6255	2260	2560	3900	2000	1500	1500	1500	A	5"	-	-
NX2-G06 /A /NR /0636	7430	2260	2560	4290	2000	1500	1500	1500	A	5"	-	-
NX2-G06 /A /NR /0676	7430	2260	2560	4430	2000	1500	1500	1500	A	5"	-	-
NX2-G06 /A /NR /0706	7430	2260	2560	4450	2000	1500	1500	1500	A	5"	-	-
NX2-G06 /A /NR /0768	9780	2260	2560	5660	2000	1500	1500	1500	A	6"	-	-
NX2-G06 /A /NR /0808	9780	2260	2560	5720	2000	1500	1500	1500	A	6"	-	-
NX2-G06 /A /NR /0848	9780	2260	2560	5770	2000	1500	1500	1500	A	6"	-	-
NX2-G06 /A /NR /0898	9780	2260	2560	5810	2000	1500	1500	1500	A	6"	-	-
NX2-G06 /A /NR /0928	9780	2260	2560	5850	2000	1500	1500	1500	A	6"	-	-
NX2-G06 /D /A /NR /0404	5080	2260	2560	2930	2000	1500	1500	1500	A	4"	A	2"
NX2-G06 /D /A /NR /0424	5080	2260	2560	2960	2000	1500	1500	1500	A	4"	A	2"
NX2-G06 /D /A /NR /0464	5080	2260	2560	3000	2000	1500	1500	1500	A	4"	A	2"
NX2-G06 /D /A /NR /0515	6255	2260	2560	3600	2000	1500	1500	1500	A	5"	A	2"1/2
NX2-G06 /D /A /NR /0576	6255	2260	2560	3830	2000	1500	1500	1500	A	5"	A	2"1/2
NX2-G06 /D /A /NR /0585	6255	2260	2560	3900	2000	1500	1500	1500	A	5"	A	2"1/2
NX2-G06 /D /A /NR /0636	7430	2260	2560	4290	2000	1500	1500	1500	A	5"	A	2"1/2
NX2-G06 /D /A /NR /0676	7430	2260	2560	4430	2000	1500	1500	1500	A	5"	A	2"1/2
NX2-G06 /D /A /NR /0706	7430	2260	2560	4450	2000	1500	1500	1500	A	5"	A	2"1/2
NX2-G06 /D /A /NR /0768	9780	2260	2560	5660	2000	1500	1500	1500	A	6"	A	2"1/2
NX2-G06 /D /A /NR /0808	9780	2260	2560	5720	2000	1500	1500	1500	A	6"	A	2"1/2
NX2-G06 /D /A /NR /0848	9780	2260	2560	5770	2000	1500	1500	1500	A	6"	A	2"1/2
NX2-G06 /D /A /NR /0898	9780	2260	2560	5810	2000	1500	1500	1500	A	6"	A	2"1/2
NX2-G06 /D /A /NR /0928	9780	2260	2560	5850	2000	1500	1500	1500	A	6"	A	2"1/2

The selection of opt. 9979 - Container packing or 9996 - Container slides decreases the height of the units, thus permitting the transport via container. With these options, the height of the units is 2450 mm.

DIMENSIONAL DRAWINGS

LEGEND OF PIPE CONNECTIONS



TYPE = A
Grooved pipe

NOMINAL PIPE SIZE	PIPE OUTSIDE DIAMETER
ø inches	ø mm
¾	26,7
1	33,7
1 ¼	42,4
1 ½	48,3
2	60,3
2 ½	76,1
3	88,9
3 ½	101,6

NOMINAL PIPE SIZE	PIPE OUTSIDE DIAMETER
ø inches	ø mm
4	114,3
4 ½	127,0
5	139,7
6	168,3
8	219,1
10	273,0
12	323,9
14	355,6

UNI ISO 228/13

Pipe threads where pressure-tight joints are not made on the threads - Designation, dimensions and tolerances

Used terminology:

G: Pipe threads where pressure-tight joints are not made on the threads

A: Close tolerance class for external pipe threads where pressure-tight joints are not made on the threads

B: Wider tolerance class for external pipe threads where pressure-tight joints are not made on the threads

Internal threads: G letter followed by thread mark (only tolerance class)

External threads: G letter followed by thread mark and by A letter for A class external threads or by B letter for B class external threads.

UNI EN 10226-1

Pipe threads where pressure-tight joints are made on the threads - Designation, dimensions and tolerances

Used terminology:

Rp: Internal cylindrical threads where pressure-tight joints are made on the threads

Rc: Internal conical threads where pressure-tight joints are made on the threads

R: External conical threads where pressure-tight joints are made on the threads

Internal cylindrical threads: R letter followed by p letter

Internal conical threads: R letter followed by c letter

External conical threads: R letter

DESIGNATION	DESCRIPTION
UNI EN 10226-1 - Rp 1 1/2	Internal cylindrical threads where pressure-tight joints are made on the threads, defined by standard UNI ISO 7/1 Conventional ø 1 1/2"
UNI EN 10226-1 - Rp 2 1/2	Internal cylindrical threads where pressure-tight joints are made on the threads, defined by standard UNI ISO 7/1 Conventional ø 2 1/2"
UNI EN 10226-1 - Rp 3	Internal cylindrical threads where pressure-tight joints are made on the threads, defined by standard UNI ISO 7/1 Conventional ø 3"
UNI EN 10226-1 - R 3	External conical threads where pressure-tight joints are made on the threads, defined by standard UNI ISO 7/1 Conventional ø 3"
UNI ISO 228/1 - G 4 B	Internal cylindrical threads where pressure-tight joints are not made on the threads, defined by standard UNI ISO 228/1 Tolerance class B for external thread Conventional ø 4"
DN 80 PN 16	Flange Nominal Diameter: 80 mm Nominal Pressure: 16 bar

NOTE:

Conventional diameter value [in inches] identifies short thread designation, based upon the relative standard.

All relative values are defined by standards.

As example, here below some values:

	UNI EN 10226-1	UNI ISO 228/1
Conventional ø	1"	1"
Pitch	2.309 mm	2.309 mm
External ø	33.249 mm	33.249 mm
Core ø	30.291 mm	30.291 mm
Thread height	1.479 mm	1.479 mm

12.1 HYDRONIC GROUP

12.1 HYDRONIC MODULE

The units can be fitted with the hydronic module includes the main water circuit components, thus optimizing water circuit and electrical installation space, times and costs.

The built-in hydronic module is available as option with single or twin in-line pump, for achieving low head or high head, fixed or variable speed and with buffer tank.

The standard configuration of the units feature:

- Terminals for external pumps control (relays + 0-10V signal)
- Differential pressure switch (on heat exchanger)
- discharge valves on exchanger
- purge valve
- safety valve (water side) (10 bar)

For the hydronic modules with pumps, the factory-mounted components are:

- 1 or 2 pumps, 2 poles, low head or high head, fixed or variable speed
- differential pressure switch (on heat exchanger)
- discharge valves on exchanger
- One-way valve (Clapet type for in-line pumps)
- purge valve
- safety valve (10 bar)

For the hydronic modules with pumps and buffer tank, the factory-mounted components are:

- 1 or 2 pumps, 2 poles, low head or high head, fixed or variable speed
- buffer tank covered by a 20 mm thick of insulation lining in closed-cell reticulated foam. Buffer tank capacity: 700 l for sizes 0404 K, 0424 K, 0464 K, 0515 K, 0576 K, 0585 K (for size 0585 K the buffer tank is not available together with dual-pump, high head hydronic module option). Buffer tank capacity 1000 l for all other sizes/versions.
- expansion tank (membrane made of EPDM) of 25 l of capacity (pre-charge: 1.5 bar) with 700 l buffer tank, 40 l of capacity (pre-charge: 1.5 bar) with 1000 l buffer tank
- differential pressure switch (on heat exchanger)
- discharge and suction valves
- One-way valve (Clapet type for in-line pumps)
- purge valve
- safety valve (6 bar)
- pressure gauge

Each of the components of the hydraulic group has been designed to optimise hydraulic and electrical installation space, time and costs.

The second pump operates in stand-by to the first.

The relative operating hours of the two pumps are balanced. In case the operating pump breaks down, the reserve pump is automatically enabled.

The electrical panel of the unit is protected with fuses and contactors with thermals cut-out.

Suction, volute and discharge of each pump and all the water pipes are covered with an insulation lining in closed-cell reticulated foam in PE, CFC and HCFC-free.

In units with opt. acoustical enclosure and NR kit, the hydronic group is protected by a self-ventilated enclosure, acoustically insulated by a 15 mm thick lining of polyester fibers (Fiberform).

12.1 IN-LINE PUMPS

Low or high head pumps

Centrifugal pumps with in-line suction and delivery flanges, in single or twin versions. Pump body in cast iron and impeller in AISI 316L stainless steel or cast-iron, entirely laser technology welded. Mechanical seal with EPDM elastomers. Three-phase electric motor protected to IP55, insulation class F, suitable for continuous service.

12.1 OTHER COMPONENTS

The following components are excluded from the hydronic kit supply, but their use is mandatory for the correct unit and system operation.

These components are available as accessories and supplied loose, it shall be the customer responsibility to install them.

- Unit inlet water filter
- Unit outlet flow-switch

It is also recommended the use of the following components:

- Unit inlet and outlet pressure gauges
- Shut-off valves

- Flexible joints on piping

12.1 SPECIAL PUMPS

For pumps with different configurations, please contact our sales department.

Possible configurations

PUMP GROUP	Versions	
	A	K
EV - 1 PUMP 2P LH (FIX SPEED)(4706)	X	X
EV - 1 PUMP 2P HP (FIX SPEED)(4707)	X	X
EV - 2 PUMPS 2P LH (FIX SPEED)(4711)	X	X
EV - 2 PUMPS 2P HP (FIX SPEED)(4712)	X	X
EV - 1 PUMP 2P LH (VAR SPEED)(4717)	X	X
EV - 1 PUMP 2P HH (VAR SPEED)(4718)	X	X
EV - 2 PUMPS 2P LH (VAR SPEED)(4722)	X	X
EV - 2 PUMPS 2P HH (VAR SPEED)(4723)	X	X

HYDRONIC GROUP

CONFIGURAZIONE GRUPPO IDRONICO CON 1/2 POMPE IN-LINE CONFIGURATION OF HYDRONIC UNIT WITH 1/2 IN-LINE PUMPS

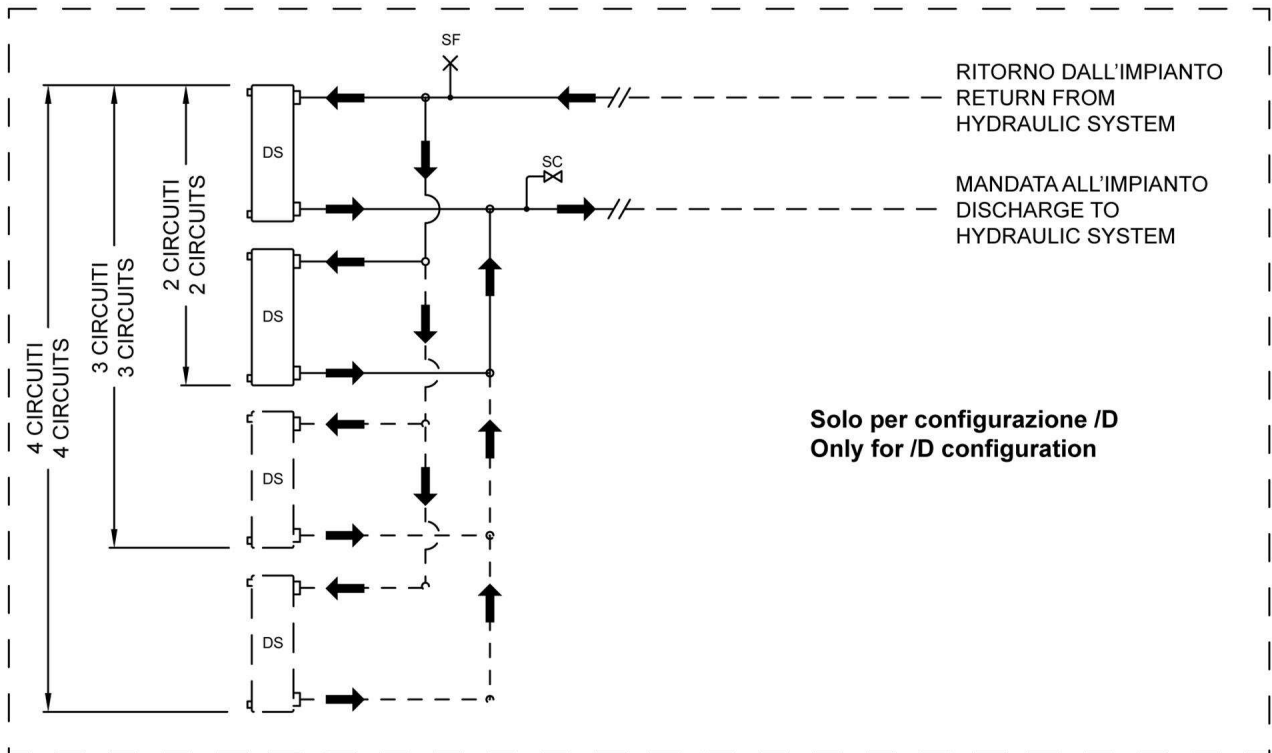
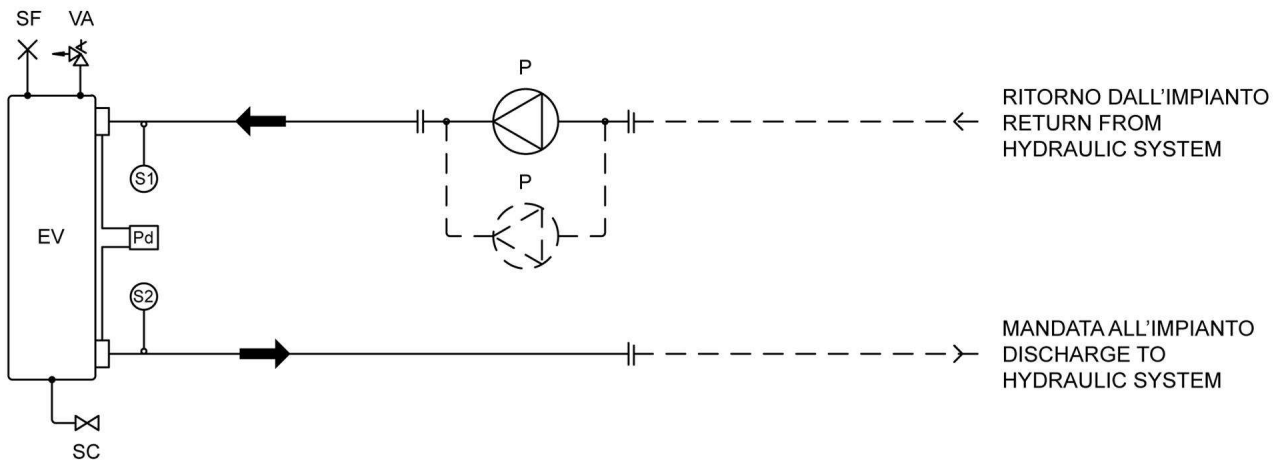

Il gruppo idronico è composto da / The hydronic unit comprises:

- EV Evaporatore (scambiatore a fascio tubiero) / Evaporator (tube exchanger)
- DS Scambiatore ausiliario (opzionale) / Desuperheater (optional)
- P Pompa solo per scambiatore freddo lato utenza / Water pump for only plant (side) cooling exchanger
- Pd Pressostato differenziale lato acqua / Water Differential pressure switch
- SC Valvola di scarico / Drain valve
- SF Valvola di sfiato / Purge valve
- S1 Sonda ingresso acqua scambiatore / Exchanger water inlet probe
- S2 Sonda uscita acqua scambiatore / Exchanger water outlet probe
- VA Valvola di sicurezza / Safety valve

HYDRONIC GROUP

CONFIGURAZIONE GRUPPO IDRONICO CON 1/2 POMPE IN-LINE CON ACCUMULO CONFIGURATION OF HYDRONIC UNIT WITH 1/2 IN-LINE PUMPS AND BUFFER TANK

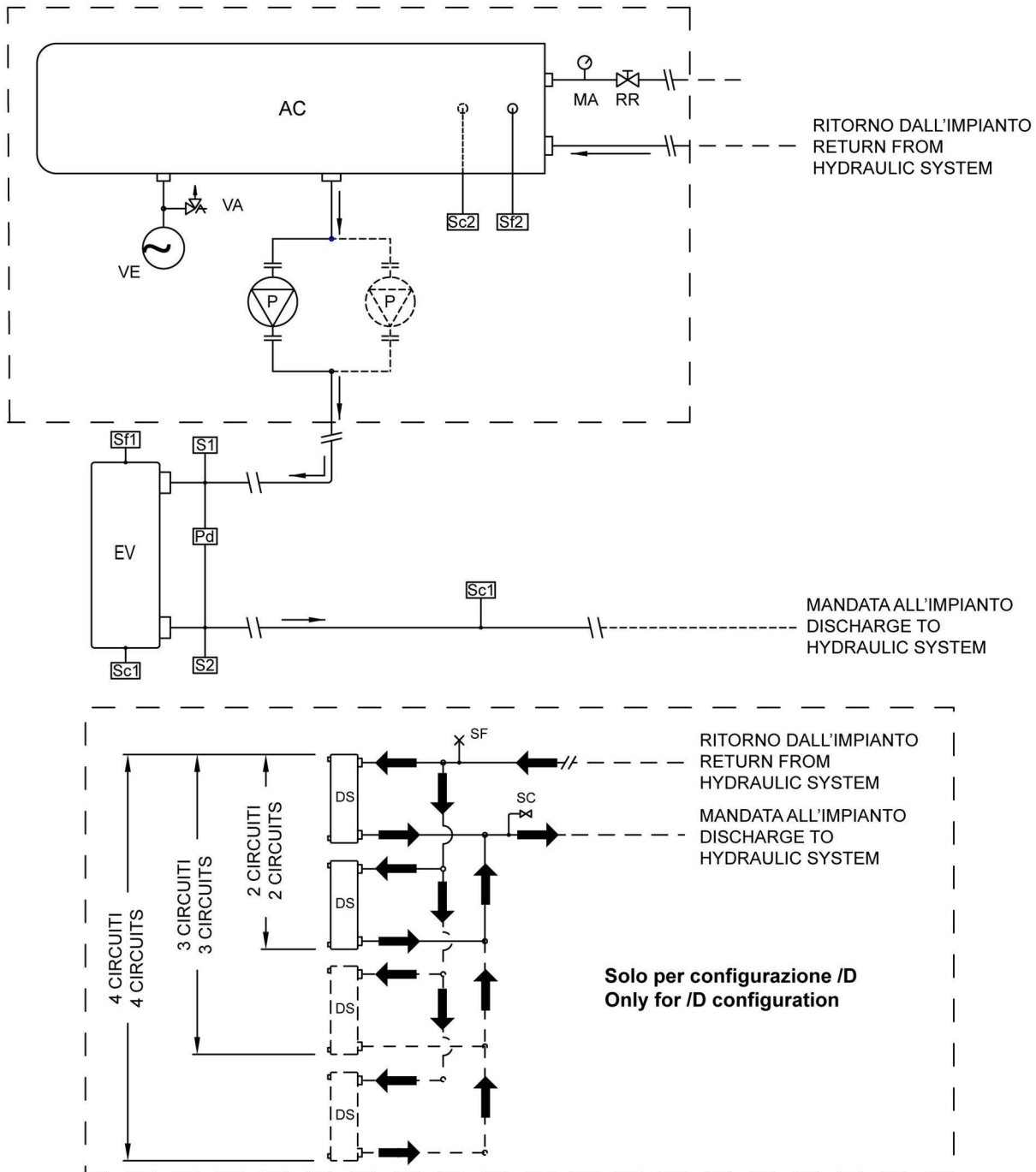

Il gruppo idronico è composto da / The hydronic unit comprises:

- AC Accumulo / Water tank
- EV Evaporatore (scambiatore a fascio tubiero) / Evaporator (tube exchanger)
- MA Manometro / Water pressure gauge
- DS Scambiatore ausiliario (opzionale) / Desuperheater (optional)
- P Pompa solo per scambiatore freddo lato utenza / Water pump for only plant (side) cooling exchanger
- Pd Pressostato differenziale lato acqua / Water Differential pressure switch
- SC Valvola di scarico / Drain valve
- RR Rubinetto reintegro / Filling valve
- SF Valvola di sfi ato / Purge valve
- S1 Sonda ingresso acqua scambiatori / Exchanger water inlet probe
- S2 Sonda uscita acqua scambiatori / Exchanger water outlet probe
- Sc1 Scarico Evaporatore/Condensatore / Evaporator/Condenser drain valve
- Sc2 Scarico acqua accumulato / Water tank drain valve
- Sf1 Sfiato Evaporatore/Condensatore / Evaporator/Condenser breather valve
- Sf2 Sfiato accumulato / Tank breather valve
- VA Valvola di sicurezza / Safety valve
- VE Vaso di espansione / Expansion tank

HYDRONIC GROUP

Hydronic kit positioning

	Version	EV - 1 PUMP 2P LH (FIX SPEED) (4706)				EV - 1 PUMP 2P HP (FIX SPEED) (4707)				EV - 2 PUMPS 2P LH (FIX SPEED) (4711)				EV - 2 PUMPS 2P HP (FIX SPEED) (4712)			
		extra L [mm]	extra W [mm]	extra H [mm]	extra WGT [kg]	extra L [mm]	extra W [mm]	extra H [mm]	extra WGT [kg]	extra L [mm]	extra W [mm]	extra H [mm]	extra WGT [kg]	extra L [mm]	extra W [mm]	extra H [mm]	extra WGT [kg]
0404	A	/	/	/	310	/	/	/	310	/	/	/	310	/	/	/	310
	A	/	/	/	310	/	/	/	310	/	/	/	310	/	/	/	310
	K	/	/	/	300	/	/	/	300	/	/	/	300	/	/	/	300
0424	A	/	/	/	320	/	/	/	320	/	/	/	320	/	/	/	320
	A	/	/	/	320	/	/	/	320	/	/	/	320	/	/	/	320
	K	/	/	/	310	/	/	/	310	/	/	/	310	/	/	/	310
0464	A	/	/	/	320	/	/	/	320	/	/	/	320	/	/	/	320
	A	/	/	/	320	/	/	/	320	/	/	/	320	/	/	/	320
	K	/	/	/	300	/	/	/	300	/	/	/	300	/	/	/	300
0515	A	/	/	/	350	/	/	/	350	/	/	/	350	/	/	/	350
	A	/	/	/	350	/	/	/	350	/	/	/	350	/	/	/	350
	K	/	/	/	330	/	/	/	330	/	/	/	330	/	/	/	330
0576	A	/	/	/	350	/	/	/	350	/	/	/	350	/	/	/	350
	A	/	/	/	350	/	/	/	350	/	/	/	350	/	/	/	350
	K	/	/	/	330	/	/	/	330	/	/	/	330	/	/	/	330
0585	A	/	/	/	370	/	/	/	370	/	/	/	370	/	/	/	370
	A	/	/	/	370	/	/	/	370	/	/	/	370	/	/	/	370
	K	/	/	/	340	/	/	/	340	/	/	/	340	/	/	/	340
0636	A	/	/	/	370	/	/	/	370	/	/	/	370	/	/	/	370
	A	/	/	/	370	/	/	/	370	/	/	/	370	/	/	/	370
	K	/	/	/	360	/	/	/	360	/	/	/	360	/	/	/	360
0676	A	/	/	/	370	/	/	/	370	/	/	/	370	/	/	/	370
	A	/	/	/	370	/	/	/	370	/	/	/	370	/	/	/	370
	K	/	/	/	370	/	/	/	370	/	/	/	370	/	/	/	370
0706	A	/	/	/	460	/	/	/	460	/	/	/	460	/	/	/	460
	A	/	/	/	460	/	/	/	460	/	/	/	460	/	/	/	460
	K	/	/	/	450	/	/	/	450	/	/	/	450	/	/	/	450
0768	A	/	/	/	460	/	/	/	460	/	/	/	460	/	/	/	460
	A	/	/	/	460	/	/	/	460	/	/	/	460	/	/	/	460
	K	/	/	/	460	/	/	/	460	/	/	/	460	/	/	/	460
0808	A	/	/	/	480	/	/	/	480	/	/	/	480	/	/	/	480
	A	/	/	/	480	/	/	/	480	/	/	/	480	/	/	/	480
	K	/	/	/	480	/	/	/	480	/	/	/	480	/	/	/	480
0848	A	/	/	/	490	/	/	/	490	/	/	/	490	/	/	/	490
	A	/	/	/	490	/	/	/	490	/	/	/	490	/	/	/	490
	K	/	/	/	480	/	/	/	480	/	/	/	480	/	/	/	480
0898	A	/	/	/	490	/	/	/	490	/	/	/	490	/	/	/	490
	A	/	/	/	490	/	/	/	490	/	/	/	490	/	/	/	490
	K	/	/	/	480	/	/	/	480	/	/	/	480	/	/	/	480
0928	A	/	/	/	490	/	/	/	490	/	/	/	490	/	/	/	490

extra L	Unit's extra length
extra W	Unit's extra operating width (NOT to be considered for transport)
extra H	Unit's extra height
extra WGT	Unit's extra weight (pumps and piping)
EV - 1 PUMP 2P LH (FIX SPEED)	EV - 1 PUMP 2P LH (FIX SPEED)
EV - 1 PUMP 2P HP (FIX SPEED)	EV - 1 PUMP 2P HP (FIX SPEED)
EV - 2 PUMPS 2P LH (FIX SPEED)	EV - 2 PUMPS 2P LH (FIX SPEED)
EV - 2 PUMPS 2P HP (FIX SPEED)	EV - 2 PUMPS 2P HP (FIX SPEED)
-	Not available

HYDRONIC GROUP

Hydronic kit positioning

	Version	EV - 1 PUMP 2P LH (FIX SPEED) (4706)				EV - 1 PUMP 2P HP (FIX SPEED) (4707)				EV - 2 PUMPS 2P LH (FIX SPEED) (4711)				EV - 2 PUMPS 2P HP (FIX SPEED) (4712)			
		extra L [mm]	extra W [mm]	extra H [mm]	extra WGT [kg]	extra L [mm]	extra W [mm]	extra H [mm]	extra WGT [kg]	extra L [mm]	extra W [mm]	extra H [mm]	extra WGT [kg]	extra L [mm]	extra W [mm]	extra H [mm]	extra WGT [kg]
0928	A	/	/	/	490	/	/	/	490	/	/	/	490	/	/	/	490
	K	/	/	/	490	/	/	/	490	/	/	/	490	/	/	/	490

extra L	Unit's extra length
extra W	Unit's extra operating width (NOT to be considered for transport)
extra H	Unit's extra height
extra WGT	Unit's extra weight (pumps and piping)
EV - 1 PUMP 2P LH (FIX SPEED)	EV - 1 PUMP 2P LH (FIX SPEED)
EV - 1 PUMP 2P HP (FIX SPEED)	EV - 1 PUMP 2P HP (FIX SPEED)
EV - 2 PUMPS 2P LH (FIX SPEED)	EV - 2 PUMPS 2P LH (FIX SPEED)
EV - 2 PUMPS 2P HP (FIX SPEED)	EV - 2 PUMPS 2P HP (FIX SPEED)
-	Not available

HYDRONIC GROUP

Hydronic kit positioning

	Version	EV - 1 PUMP 2P LH (VAR SPEED) (4717)				EV - 1 PUMP 2P HH (VAR SPEED) (4718)				EV - 2 PUMPS 2P LH (VAR SPEED) (4722)				EV - 2 PUMPS 2P HH (VAR SPEED) (4723)			
		extra L [mm]	extra W [mm]	extra H [mm]	extra WGT [kg]	extra L [mm]	extra W [mm]	extra H [mm]	extra WGT [kg]	extra L [mm]	extra W [mm]	extra H [mm]	extra WGT [kg]	extra L [mm]	extra W [mm]	extra H [mm]	extra WGT [kg]
0404	A	/	/	/	310	/	/	/	310	/	/	/	310	/	/	/	310
	A	/	/	/	310	/	/	/	310	/	/	/	310	/	/	/	310
	K	/	/	/	300	/	/	/	300	/	/	/	300	/	/	/	300
0424	A	/	/	/	320	/	/	/	320	/	/	/	320	/	/	/	320
	A	/	/	/	320	/	/	/	320	/	/	/	320	/	/	/	320
	K	/	/	/	310	/	/	/	310	/	/	/	310	/	/	/	310
0464	A	/	/	/	320	/	/	/	320	/	/	/	320	/	/	/	320
	A	/	/	/	320	/	/	/	320	/	/	/	320	/	/	/	320
	K	/	/	/	300	/	/	/	300	/	/	/	300	/	/	/	300
0515	A	/	/	/	350	/	/	/	350	/	/	/	350	/	/	/	350
	A	/	/	/	350	/	/	/	350	/	/	/	350	/	/	/	350
	K	/	/	/	330	/	/	/	330	/	/	/	330	/	/	/	330
0576	A	/	/	/	350	/	/	/	350	/	/	/	350	/	/	/	350
	A	/	/	/	350	/	/	/	350	/	/	/	350	/	/	/	350
	K	/	/	/	330	/	/	/	330	/	/	/	330	/	/	/	330
0585	A	/	/	/	370	/	/	/	370	/	/	/	370	/	/	/	370
	A	/	/	/	370	/	/	/	370	/	/	/	370	/	/	/	370
	K	/	/	/	340	/	/	/	340	/	/	/	340	/	/	/	340
0636	A	/	/	/	370	/	/	/	370	/	/	/	370	/	/	/	370
	A	/	/	/	370	/	/	/	370	/	/	/	370	/	/	/	370
	K	/	/	/	360	/	/	/	360	/	/	/	360	/	/	/	360
0676	A	/	/	/	370	/	/	/	370	/	/	/	370	/	/	/	370
	A	/	/	/	370	/	/	/	370	/	/	/	370	/	/	/	370
	K	/	/	/	370	/	/	/	370	/	/	/	370	/	/	/	370
0706	A	/	/	/	460	/	/	/	460	/	/	/	460	/	/	/	460
	A	/	/	/	460	/	/	/	460	/	/	/	460	/	/	/	460
	K	/	/	/	450	/	/	/	450	/	/	/	450	/	/	/	450
0768	A	/	/	/	460	/	/	/	460	/	/	/	460	/	/	/	460
	A	/	/	/	460	/	/	/	460	/	/	/	460	/	/	/	460
	K	/	/	/	460	/	/	/	460	/	/	/	460	/	/	/	460
0808	A	/	/	/	480	/	/	/	480	/	/	/	480	/	/	/	480
	A	/	/	/	480	/	/	/	480	/	/	/	480	/	/	/	480
	K	/	/	/	480	/	/	/	480	/	/	/	480	/	/	/	480
0848	A	/	/	/	490	/	/	/	490	/	/	/	490	/	/	/	490
	A	/	/	/	490	/	/	/	490	/	/	/	490	/	/	/	490
	K	/	/	/	480	/	/	/	480	/	/	/	480	/	/	/	480
0898	A	/	/	/	490	/	/	/	490	/	/	/	490	/	/	/	490
	A	/	/	/	490	/	/	/	490	/	/	/	490	/	/	/	490
	K	/	/	/	480	/	/	/	480	/	/	/	480	/	/	/	480
0928	A	/	/	/	490	/	/	/	490	/	/	/	490	/	/	/	490

- extra L Unit's extra length
- extra W Unit's extra operating width (NOT to be considered for transport)
- extra H Unit's extra height
- extra WGT Unit's extra weight (pumps and piping)
- EV - 1 PUMP 2P LH (VAR SPEED) EV - 1 PUMP 2P LH (VAR SPEED)
- EV - 1 PUMP 2P HH (VAR SPEED) EV - 1 PUMP 2P HH (VAR SPEED)
- EV - 2 PUMPS 2P LH (VAR SPEED) EV - 2 PUMPS 2P LH (VAR SPEED)
- EV - 2 PUMPS 2P HH (VAR SPEED) EV - 2 PUMPS 2P HH (VAR SPEED)
- Not available



HYDRONIC GROUP

Hydronic kit positioning

	Version	EV - 1 PUMP 2P LH (VAR SPEED) (4717)				EV - 1 PUMP 2P HH (VAR SPEED) (4718)				EV - 2 PUMPS 2P LH (VAR SPEED) (4722)				EV - 2 PUMPS 2P HH (VAR SPEED) (4723)			
		extra L [mm]	extra W [mm]	extra H [mm]	extra WGT [kg]	extra L [mm]	extra W [mm]	extra H [mm]	extra WGT [kg]	extra L [mm]	extra W [mm]	extra H [mm]	extra WGT [kg]	extra L [mm]	extra W [mm]	extra H [mm]	extra WGT [kg]
0928	A	/	/	/	490	/	/	/	490	/	/	/	490	/	/	/	490
	K	/	/	/	490	/	/	/	490	/	/	/	490	/	/	/	490

extra L	Unit's extra length
extra W	Unit's extra operating width (NOT to be considered for transport)
extra H	Unit's extra height
extra WGT	Unit's extra weight (pumps and piping)
EV - 1 PUMP 2P LH (VAR SPEED)	EV - 1 PUMP 2P LH (VAR SPEED)
EV - 1 PUMP 2P HH (VAR SPEED)	EV - 1 PUMP 2P HH (VAR SPEED)
EV - 2 PUMPS 2P LH (VAR SPEED)	EV - 2 PUMPS 2P LH (VAR SPEED)
EV - 2 PUMPS 2P HH (VAR SPEED)	EV - 2 PUMPS 2P HH (VAR SPEED)
-	Not available

HYDRONIC GROUP

HEAT EXCHANGER USER SIDE - EV - 1 PUMP 2P HH (VAR SPEED)

SIZE		CH		PUMP					CH				
		Pfgross	Qfgross	Rif.	Model	N.	F.L.A.	F.L.I.	HU				
		[kW] (1)	[l/s] (1)			Pole	[A]	[kW]	[kPa]				
0404	A	380,1	18,18	A1	LNEE 80-160/75/2	2	14	7,500	176				
	A	379,7	18,16						176				
	K	379,1	18,13						176				
0424	A	400,0	19,13	A2					184				
	A	399,2	19,09						185				
	K	398,9	19,08						185				
0464	A	439,8	21,03	A3		165							
	A	437,6	20,92			166							
	K	437,0	20,90			166							
0515	A	490,2	23,44	B1		LNEE 80-160/92/2	2	17	9,200	196			
	A	487,8	23,33							197			
	K	488,0	23,34							197			
0576	A	540,8	25,86	B2	169								
	A	538,8	25,76		170								
	K	538,9	25,77		170								
0585	A	548,6	26,24	C1	LNEE 80-160/110/2	2	20	11,00	231				
	A	546,4	26,13						232				
	K	546,7	26,14						232				
0636	A	599,7	28,68	C2					207				
	A	597,3	28,56						208				
	K	597,9	28,59						208				
0676	A	639,0	30,56	C3		195							
	A	636,5	30,44			196							
	K	636,3	30,43			197							
0706	A	658,6	31,50	C4		185							
	A	655,3	31,34			187							
	K	656,5	31,39			186							
0768	A	721,1	34,49	D1	LNEE 80-160/150/2	2	27	15,00	251				
	A	720,4	34,45						251				
	K	720,5	34,45						251				
0808	A	762,2	36,45	E1					LNEE 100-160/185/2	2	33	18,50	241
	A	760,7	36,38										242
	K	759,5	36,32										242
0848	A	801,1	38,31	E2	251								
	A	798,7	38,20		252								
	K	798,1	38,17		252								
0898	A	839,7	40,16	E3	240								
	A	837,2	40,04		241								
	K	835,5	39,96		241								
0928	A	872,3	41,72	E4	230								
	A	868,8	41,55		231								
	K	867,1	41,46		232								

(1) Values refer to nominal conditions
 CH Cooling mode
 Pf Cooling capacity unit (Cooling mode)
 Pt Heating capacity unit (Heating mode)

Q Plant (side) exchanger water flow
 F.L.I. Pump power input
 F.L.A. Pump running current
 HU Pump residual pressure head (Units with hydronic group without mains filter)

HEAT EXCHANGER USER SIDE - EV - 1 PUMP 2P HH (VAR SPEED)

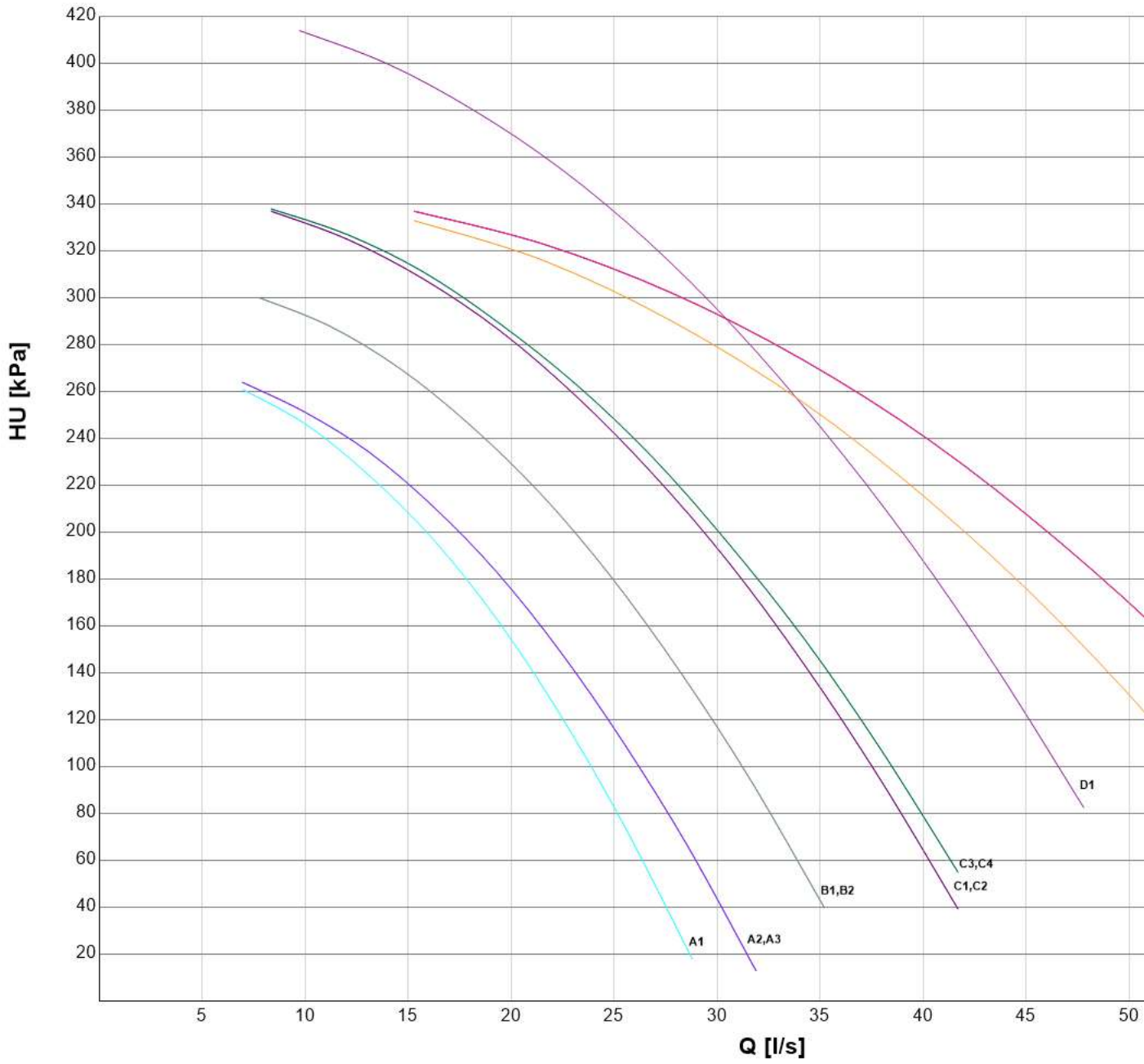

HYDRONIC GROUP

HEAT EXCHANGER USER SIDE - EV - 1 PUMP 2P HP (FIX SPEED)

SIZE		CH		PUMP					CH
		Pfgross	Qfgross	Rif.	Model	N.	F.L.A.	F.L.I.	HU
		[kW] (1)	[l/s] (1)			Pole	[A]	[kW]	[kPa]
0404	A	380,1	18,18	A1					176
	A	379,7	18,16						176
	K	379,1	18,13						176
0424	A	400,0	19,13	A2	LNEE 80-160/75/2	2	14	7,500	184
	A	399,2	19,09						185
	K	398,9	19,08						185
0464	A	439,8	21,03	A3					165
	A	437,6	20,92						166
	K	437,0	20,90						166
0515	A	490,2	23,44	B1	LNEE 80-160/92/2	2	17	9,200	196
	A	487,8	23,33						197
	K	488,0	23,34						197
0576	A	540,8	25,86	B2					169
	A	538,8	25,76						170
	K	538,9	25,77						170
0585	A	548,6	26,24	C1					231
	A	546,4	26,13						232
	K	546,7	26,14						232
0636	A	599,7	28,68	C2	LNEE 80-160/110/2	2	20	11,00	207
	A	597,3	28,56						208
	K	597,9	28,59						208
0676	A	639,0	30,56	C3					195
	A	636,5	30,44						196
	K	636,3	30,43						197
0706	A	658,6	31,50	C4					185
	A	655,3	31,34						187
	K	656,5	31,39						186
0768	A	721,1	34,49	D1	LNEE 80-160/150/2	2	27	15,00	251
	A	720,4	34,45						251
	K	720,5	34,45						251
0808	A	762,2	36,45	E1	LNEE 100-160/185/2	2	33	18,50	241
	A	760,7	36,38						242
	K	759,5	36,32						242
0848	A	801,1	38,31	E2					251
	A	798,7	38,20						252
	K	798,1	38,17						252
0898	A	839,7	40,16	E3					240
	A	837,2	40,04						241
	K	835,5	39,96						241
0928	A	872,3	41,72	E4					230
	A	868,8	41,55						231
	K	867,1	41,46						232

(1) Values refer to nominal conditions
 CH Cooling mode
 Pf Cooling capacity unit (Cooling mode)
 Pt Heating capacity unit (Heating mode)

Q Plant (side) exchanger water flow
 F.L.I. Pump power input
 F.L.A. Pump running current
 HU Pump residual pressure head (Units with hydronic group without mains filter)

HEAT EXCHANGER USER SIDE - EV - 1 PUMP 2P HP (FIX SPEED)

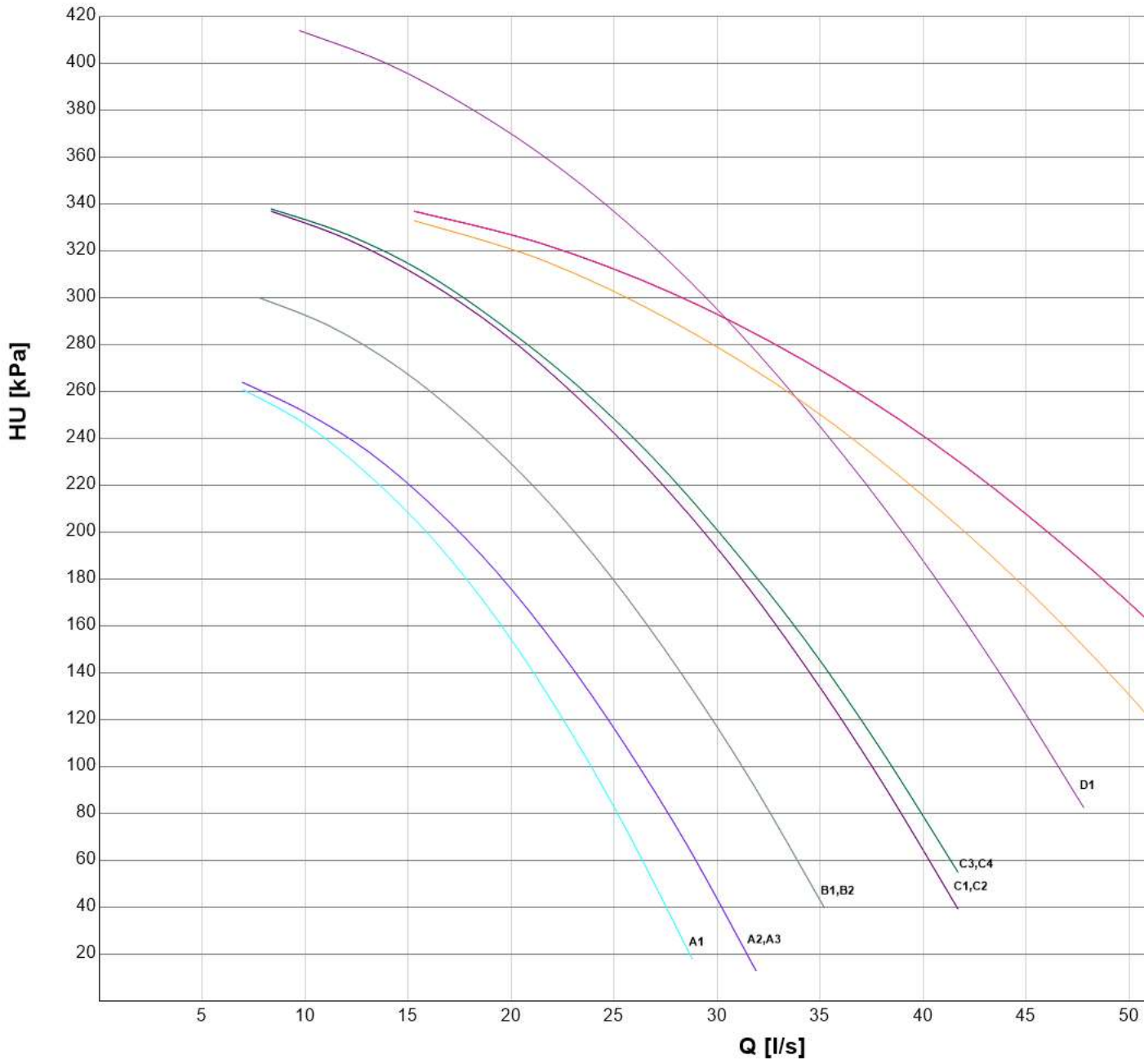

HYDRONIC GROUP

HEAT EXCHANGER USER SIDE - EV - 1 PUMP 2P LH (FIX SPEED)

SIZE		CH		PUMP					CH
		Pfgross	Qfgross	Rif.	Model	N.	F.L.A.	F.L.I.	HU
		[kW] (1)	[l/s] (1)			Pole	[A]	[kW]	[kPa]
0404	A	380,1	18,18	A1					132
	A	379,7	18,16						132
	K	379,1	18,13						132
0424	A	400,0	19,13	A2	LNEE 65-125/55/2	2	11	5,500	135
	A	399,2	19,09						135
	K	398,9	19,08						136
0464	A	439,8	21,03	A3					102
	A	437,6	20,92						104
	K	437,0	20,90						104
0515	A	490,2	23,44	B1	LNEE 65-125/75/2	2	14	7,500	122
	A	487,8	23,33						124
	K	488,0	23,34						124
0576	A	540,8	25,86	C1					127
	A	538,8	25,76						128
	K	538,9	25,77						128
0585	A	548,6	26,24	C2	LNEE 80-160/75/2	2	14	7,500	149
	A	546,4	26,13						150
	K	546,7	26,14						150
0636	A	599,7	28,68	C3					123
	A	597,3	28,56						124
	K	597,9	28,59						124
0676	A	639,0	30,56	D1					106
	A	636,5	30,44						107
	K	636,3	30,43						107
0706	A	658,6	31,50	D2	LNES 100-250/75/4	4	14	7,500	99,0
	A	655,3	31,34						100
	K	656,5	31,39						99,8
0768	A	721,1	34,49	E1					148
	A	720,4	34,45						148
	K	720,5	34,45						148
0808	A	762,2	36,45	E2					134
	A	760,7	36,38						134
	K	759,5	36,32						135
0848	A	801,1	38,31	E3	LNEE 100-160/110/2	2	20	11,00	142
	A	798,7	38,20						143
	K	798,1	38,17						143
0898	A	839,7	40,16	E4					129
	A	837,2	40,04						130
	K	835,5	39,96						131
0928	A	872,3	41,72	E5					118
	A	868,8	41,55						119
	K	867,1	41,46						120

(1) Values refer to nominal conditions
 CH Cooling mode
 Pf Cooling capacity unit (Cooling mode)
 Pt Heating capacity unit (Heating mode)

Q Plant (side) exchanger water flow
 F.L.I. Pump power input
 F.L.A. Pump running current
 HU Pump residual pressure head (Units with hydronic group without mains filter)

HEAT EXCHANGER USER SIDE - EV - 1 PUMP 2P LH (FIX SPEED)

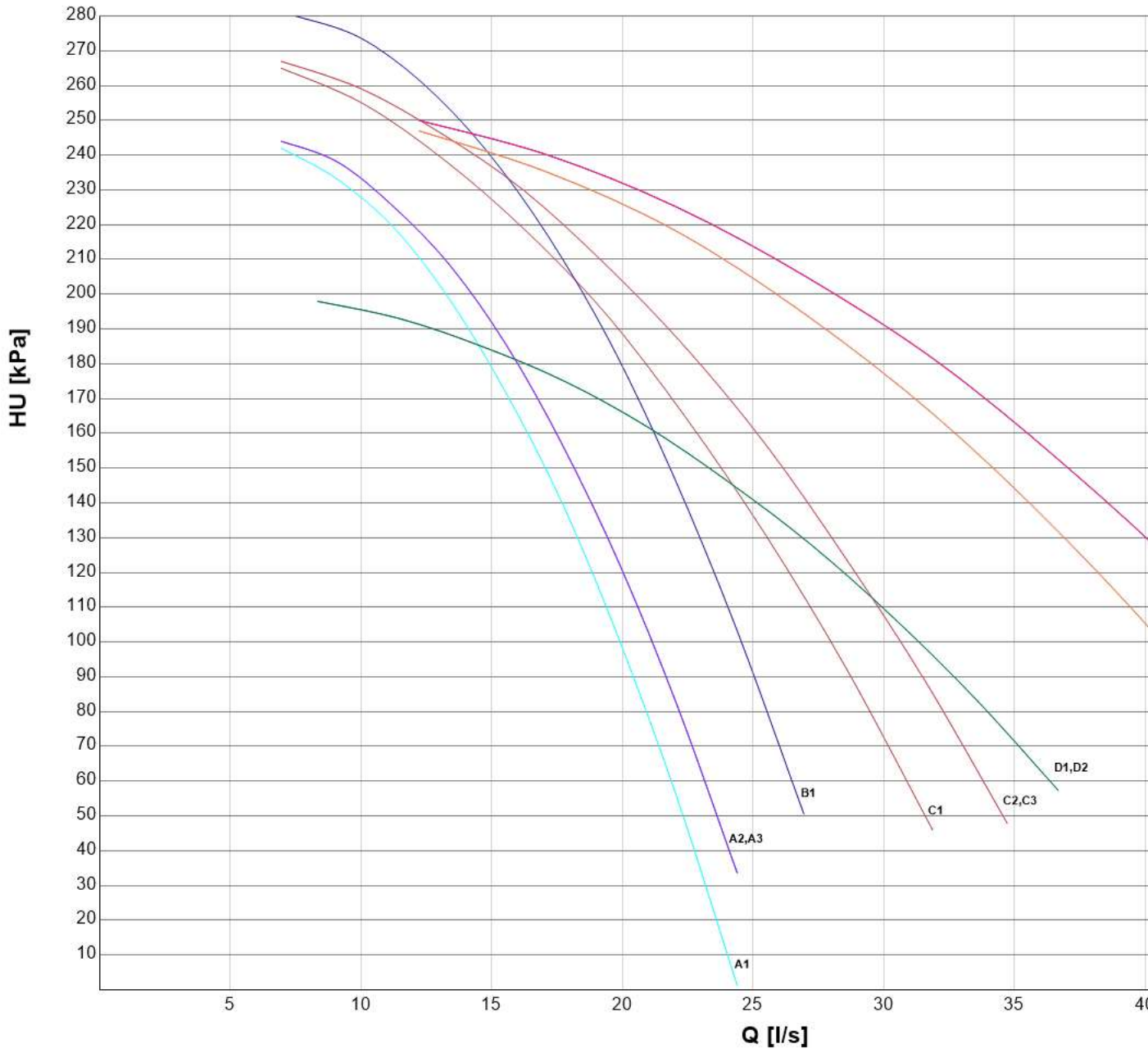

HYDRONIC GROUP

HEAT EXCHANGER USER SIDE - EV - 1 PUMP 2P LH (VAR SPEED)

SIZE		CH		PUMP					CH
		Pfgross	Qfgross	Rif.	Model	N.	F.L.A.	F.L.I.	HU
		[kW] (1)	[l/s] (1)			Pole	[A]	[kW]	[kPa]
0404	A	380,1	18,18	A1					132
	A	379,7	18,16						132
	K	379,1	18,13						132
0424	A	400,0	19,13	A2	LNEE 65-125/55/2	2	11	5,500	135
	A	399,2	19,09						135
	K	398,9	19,08						136
0464	A	439,8	21,03	A3					102
	A	437,6	20,92						104
	K	437,0	20,90						104
0515	A	490,2	23,44	B1	LNEE 65-125/75/2	2	14	7,500	122
	A	487,8	23,33						124
	K	488,0	23,34						124
0576	A	540,8	25,86	C1					127
	A	538,8	25,76						128
	K	538,9	25,77						128
0585	A	548,6	26,24	C2	LNEE 80-160/75/2	2	14	7,500	149
	A	546,4	26,13						150
	K	546,7	26,14						150
0636	A	599,7	28,68	C3					123
	A	597,3	28,56						124
	K	597,9	28,59						124
0676	A	639,0	30,56	D1					106
	A	636,5	30,44						107
	K	636,3	30,43						107
0706	A	658,6	31,50	D2	LNES 100-250/75/4	4	14	7,500	99,0
	A	655,3	31,34						100
	K	656,5	31,39						99,8
0768	A	721,1	34,49	E1					148
	A	720,4	34,45						148
	K	720,5	34,45						148
0808	A	762,2	36,45	E2					134
	A	760,7	36,38						134
	K	759,5	36,32						135
0848	A	801,1	38,31	E3	LNEE 100-160/110/2	2	20	11,00	142
	A	798,7	38,20						143
	K	798,1	38,17						143
0898	A	839,7	40,16	E4					129
	A	837,2	40,04						130
	K	835,5	39,96						131
0928	A	872,3	41,72	E5					118
	A	868,8	41,55						119
	K	867,1	41,46						120

(1) Values refer to nominal conditions
 CH Cooling mode
 Pf Cooling capacity unit (Cooling mode)
 Pt Heating capacity unit (Heating mode)

Q Plant (side) exchanger water flow
 F.L.I. Pump power input
 F.L.A. Pump running current
 HU Pump residual pressure head (Units with hydronic group without mains filter)

HEAT EXCHANGER USER SIDE - EV - 1 PUMP 2P LH (VAR SPEED)

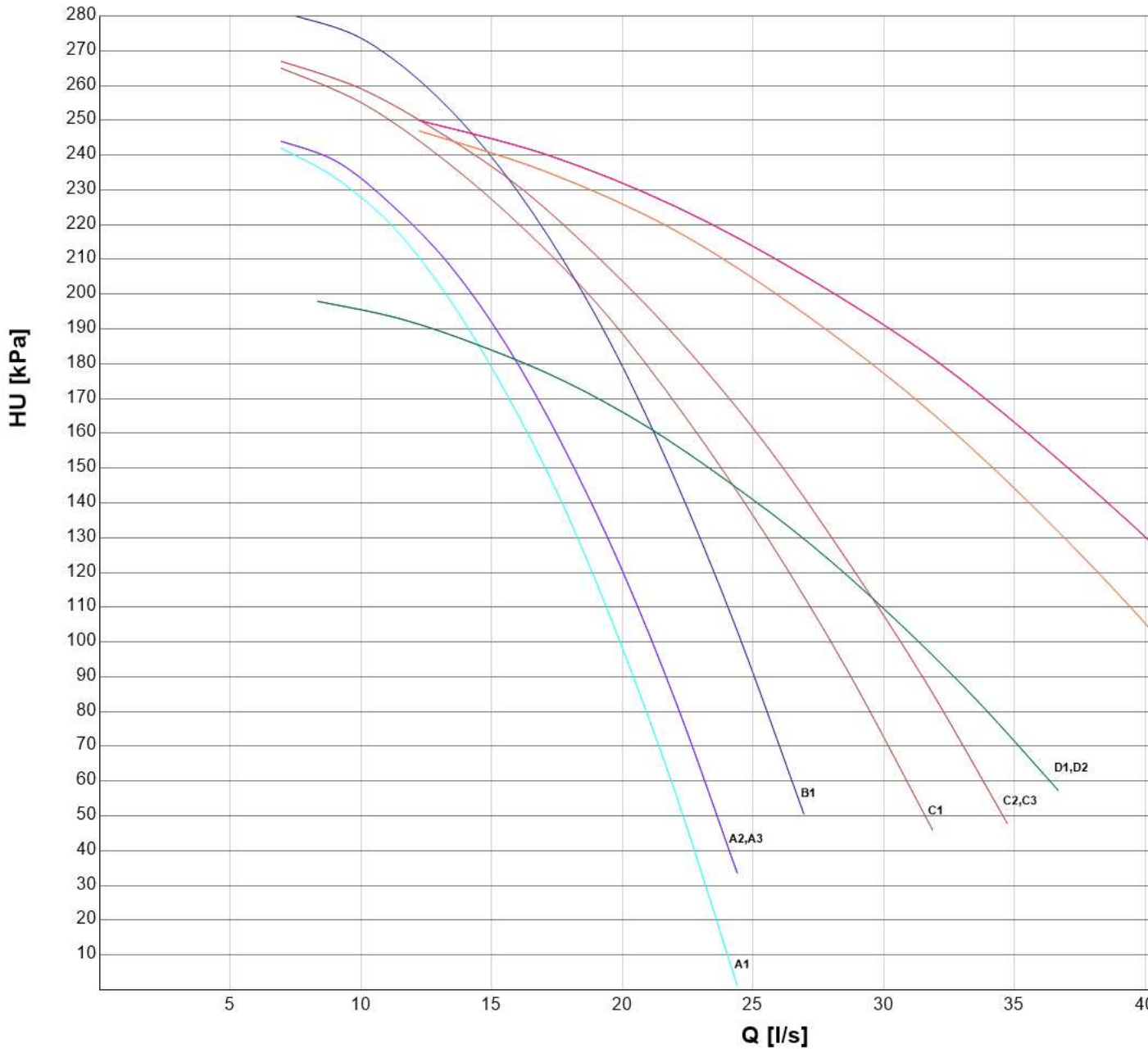

HYDRONIC GROUP

HEAT EXCHANGER USER SIDE - EV - 2 PUMPS 2P HH (VAR SPEED)

SIZE		CH		PUMP					CH
		Pfgross	Qfgross	Rif.	Model	N.	F.L.A.	F.L.I.	HU
		[kW] (1)	[l/s] (1)			Pole	[A]	[kW]	[kPa]
0404	A	380,1	18,18	A1					184
	A	379,7	18,16						184
	K	379,1	18,13						184
0424	A	400,0	19,13	A2	LNTE 80-160/75/2	2	14	7,500	193
	A	399,2	19,09						193
	K	398,9	19,08						193
0464	A	439,8	21,03	A3					172
	A	437,6	20,92						173
	K	437,0	20,90						173
0515	A	490,2	23,44	B1	LNTE 80-160/92/2	2	17	9,200	189
	A	487,8	23,33						190
	K	488,0	23,34						190
0576	A	540,8	25,86	B2					160
	A	538,8	25,76						161
	K	538,9	25,77						161
0585	A	548,6	26,24	C1					222
	A	546,4	26,13						223
	K	546,7	26,14						223
0636	A	599,7	28,68	C2	LNTE 80-160/110/2	2	20	11,00	196
	A	597,3	28,56						197
	K	597,9	28,59						196
0676	A	639,0	30,56	C3					182
	A	636,5	30,44						183
	K	636,3	30,43						183
0706	A	658,6	31,50	D1	LNTE 100-160/150/2	2	27	15,00	211
	A	655,3	31,34						212
	K	656,5	31,39						212
0768	A	721,1	34,49	D2					200
	A	720,4	34,45						200
	K	720,5	34,45						200
0808	A	762,2	36,45	E1					233
	A	760,7	36,38						233
	K	759,5	36,32						234
0848	A	801,1	38,31	E2	LNTE 100-160/185/2	2	33	18,50	242
	A	798,7	38,20						243
	K	798,1	38,17						243
0898	A	839,7	40,16	E3					230
	A	837,2	40,04						230
	K	835,5	39,96						231
0928	A	872,3	41,72	E4					219
	A	868,8	41,55						220
	K	867,1	41,46						221

(1) Values refer to nominal conditions
 CH Cooling mode
 Pf Cooling capacity unit (Cooling mode)
 Pt Heating capacity unit (Heating mode)

Q Plant (side) exchanger water flow
 F.L.I. Pump power input
 F.L.A. Pump running current
 HU Pump residual pressure head (Units with hydronic group without mains filter)

HEAT EXCHANGER USER SIDE - EV - 2 PUMPS 2P HH (VAR SPEED)

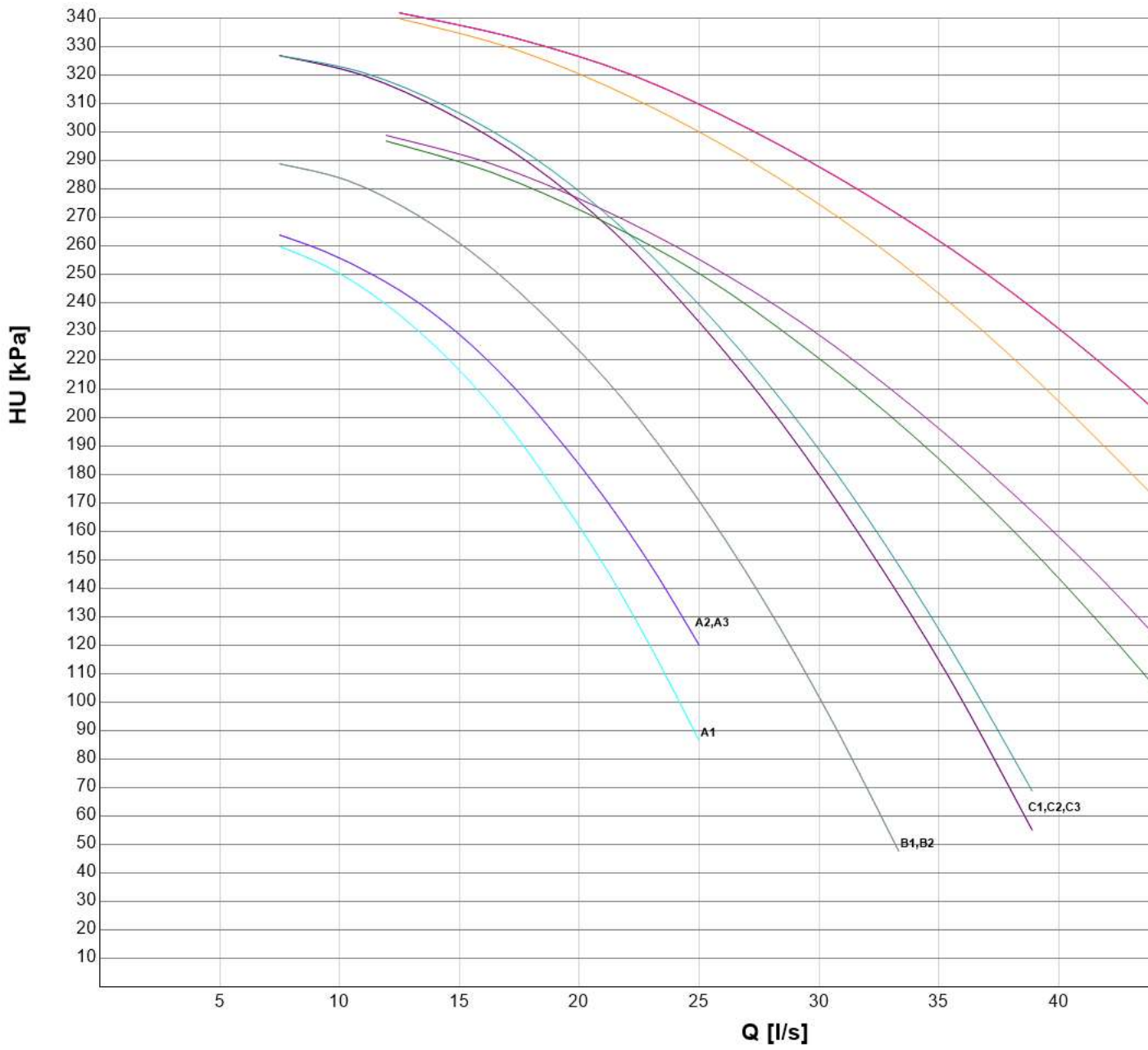

HYDRONIC GROUP

HEAT EXCHANGER USER SIDE - EV - 2 PUMPS 2P HP (FIX SPEED)

SIZE		CH		PUMP					CH
		Pfgross	Qfgross	Rif.	Model	N.	F.L.A.	F.L.I.	HU
		[kW] (1)	[l/s] (1)			Pole	[A]	[kW]	[kPa]
0404	A	380,1	18,18	A1					184
	A	379,7	18,16						184
	K	379,1	18,13						184
0424	A	400,0	19,13	A2	LNTE 80-160/75/2	2	14	7,500	193
	A	399,2	19,09						193
	K	398,9	19,08						193
0464	A	439,8	21,03	A3					172
	A	437,6	20,92						173
	K	437,0	20,90						173
0515	A	490,2	23,44	B1	LNTE 80-160/92/2	2	17	9,200	189
	A	487,8	23,33						190
	K	488,0	23,34						190
0576	A	540,8	25,86	B2					160
	A	538,8	25,76						161
	K	538,9	25,77						161
0585	A	548,6	26,24	C1					222
	A	546,4	26,13						223
	K	546,7	26,14						223
0636	A	599,7	28,68	C2	LNTE 80-160/110/2	2	20	11,00	196
	A	597,3	28,56						197
	K	597,9	28,59						196
0676	A	639,0	30,56	C3					182
	A	636,5	30,44						183
	K	636,3	30,43						183
0706	A	658,6	31,50	D1	LNTE 100-160/150/2	2	27	15,00	211
	A	655,3	31,34						212
	K	656,5	31,39						212
0768	A	721,1	34,49	D2					200
	A	720,4	34,45						200
	K	720,5	34,45						200
0808	A	762,2	36,45	E1					233
	A	760,7	36,38						233
	K	759,5	36,32						234
0848	A	801,1	38,31	E2	LNTE 100-160/185/2	2	33	18,50	242
	A	798,7	38,20						243
	K	798,1	38,17						243
0898	A	839,7	40,16	E3					230
	A	837,2	40,04						230
	K	835,5	39,96						231
0928	A	872,3	41,72	E4					219
	A	868,8	41,55						220
	K	867,1	41,46						221

(1) Values refer to nominal conditions
 CH Cooling mode
 Pf Cooling capacity unit (Cooling mode)
 Pt Heating capacity unit (Heating mode)

Q Plant (side) exchanger water flow
 F.L.I. Pump power input
 F.L.A. Pump running current
 HU Pump residual pressure head (Units with hydronic group without mains filter)

HEAT EXCHANGER USER SIDE - EV - 2 PUMPS 2P HP (FIX SPEED)

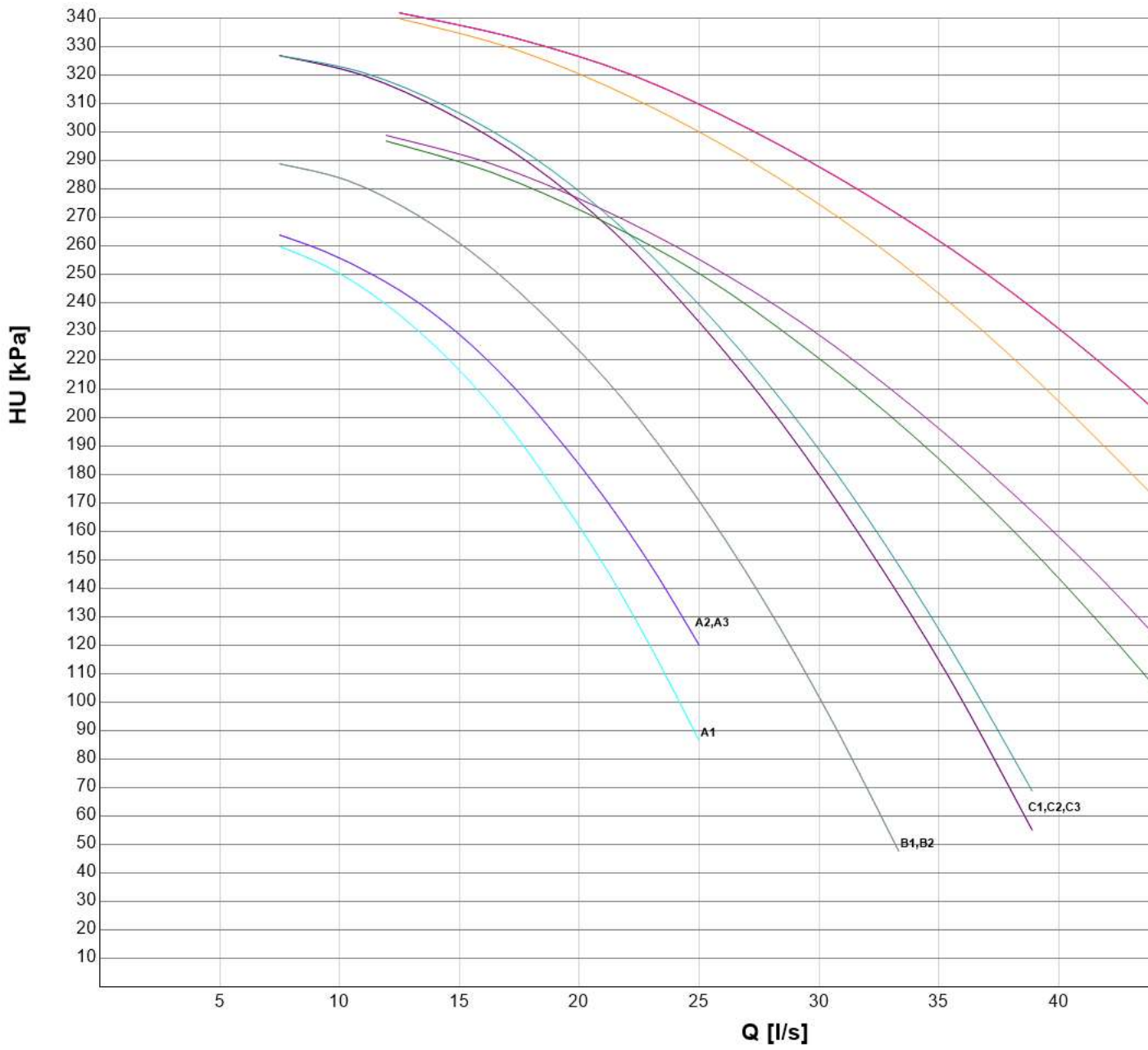

HYDRONIC GROUP

HEAT EXCHANGER USER SIDE - EV - 2 PUMPS 2P LH (FIX SPEED)

SIZE	CH			PUMP					CH
	Pfgross	Qfgross	Rif.	Model	N.	F.L.A.	F.L.I.	HU	
	[kW] (1)	[l/s] (1)			Pole	[A]	[kW]	[kPa]	
0404	A	380,1	18,18	A1	LNTE 65-125/55/2	2	11	5,500	123
	A	379,7	18,16						123
	K	379,1	18,13						124
0424	A	400,0	19,13	A2	LNTE 65-125/55/2	2	11	5,500	127
	A	399,2	19,09						127
	K	398,9	19,08						128
0464	A	439,8	21,03	B1	LNTE 100-250/75/4	4	15	7,500	124
	A	437,6	20,92						124
	K	437,0	20,90						125
0515	A	490,2	23,44	C1	LNTE 100-250/55/4	4	15	5,500	95,4
	A	487,8	23,33						96,3
	K	488,0	23,34						96,2
0576	A	540,8	25,86	D1	LNTE 100-250/75/4	4	15	7,500	102
	A	538,8	25,76						103
	K	538,9	25,77						103
0585	A	548,6	26,24	D2	LNTE 100-250/75/4	4	15	7,500	126
	A	546,4	26,13						126
	K	546,7	26,14						126
0636	A	599,7	28,68	D3	LNTE 100-250/75/4	4	15	7,500	109
	A	597,3	28,56						109
	K	597,9	28,59						109
0676	A	639,0	30,56	D4	LNTE 100-250/75/4	4	15	7,500	103
	A	636,5	30,44						104
	K	636,3	30,43						104
0706	A	658,6	31,50	D5	LNTE 100-250/75/4	4	15	7,500	95,5
	A	655,3	31,34						96,7
	K	656,5	31,39						96,3
0768	A	721,1	34,49	E1	LNTE 100-160/110/2	2	20	11,00	138
	A	720,4	34,45						138
	K	720,5	34,45						138
0808	A	762,2	36,45	E2	LNTE 100-160/110/2	2	20	11,00	123
	A	760,7	36,38						123
	K	759,5	36,32						124
0848	A	801,1	38,31	E3	LNTE 100-160/110/2	2	20	11,00	131
	A	798,7	38,20						131
	K	798,1	38,17						132
0898	A	839,7	40,16	F1	LNTE 100-160/150/2	2	27	15,00	182
	A	837,2	40,04						183
	K	835,5	39,96						183
0928	A	872,3	41,72	F2	LNTE 100-160/150/2	2	27	15,00	171
	A	868,8	41,55						172
	K	867,1	41,46						172

(1) Values refer to nominal conditions
 CH Cooling mode
 Pf Cooling capacity unit (Cooling mode)
 Pt Heating capacity unit (Heating mode)

Q Plant (side) exchanger water flow
 F.L.I. Pump power input
 F.L.A. Pump running current
 HU Pump residual pressure head (Units with hydronic group without mains filter)

HEAT EXCHANGER USER SIDE - EV - 2 PUMPS 2P LH (FIX SPEED)

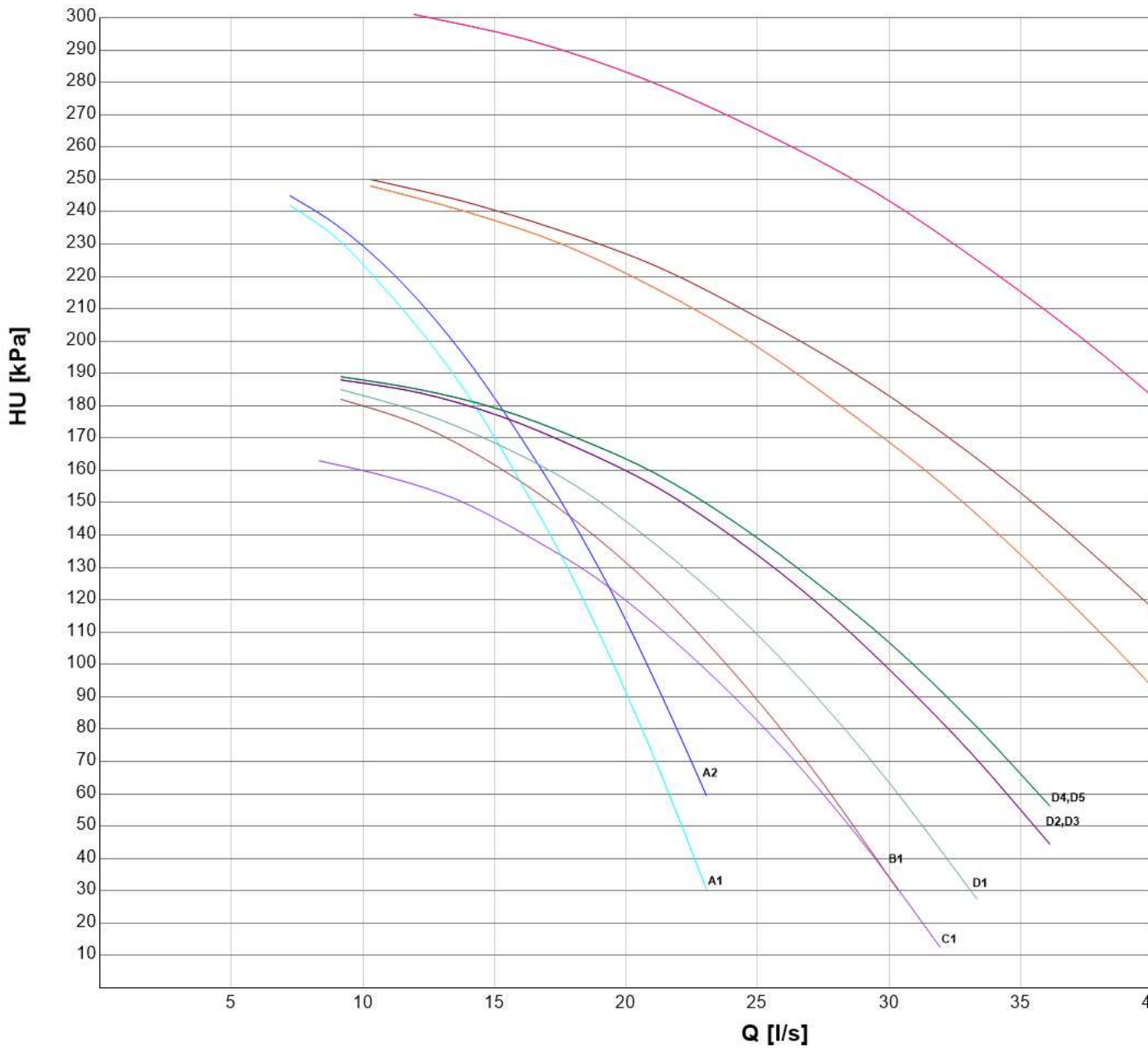

HYDRONIC GROUP

HEAT EXCHANGER USER SIDE - EV - 2 PUMPS 2P LH (VAR SPEED)

SIZE		CH		PUMP					CH
		Pfgross	Qfgross	Rif.	Model	N.	F.L.A.	F.L.I.	HU
		[kW] (1)	[l/s] (1)			Pole	[A]	[kW]	[kPa]
0404	A	380,1	18,18	A1	LNTE 65-125/55/2	2	11	5,500	123
	A	379,7	18,16						123
	K	379,1	18,13						124
0424	A	400,0	19,13	A2	LNTE 65-125/55/2	2	11	5,500	127
	A	399,2	19,09						127
	K	398,9	19,08						128
0464	A	439,8	21,03	B1	LNTE 100-250/75/4	4	15	7,500	124
	A	437,6	20,92						124
	K	437,0	20,90						125
0515	A	490,2	23,44	C1	LNTE 100-250/55/4	4	15	5,500	95,4
	A	487,8	23,33						96,3
	K	488,0	23,34						96,2
0576	A	540,8	25,86	D1	LNTE 100-250/75/4	4	15	7,500	102
	A	538,8	25,76						103
	K	538,9	25,77						103
0585	A	548,6	26,24	D2	LNTE 100-250/75/4	4	15	7,500	126
	A	546,4	26,13						126
	K	546,7	26,14						126
0636	A	599,7	28,68	D3	LNTE 100-250/75/4	4	15	7,500	109
	A	597,3	28,56						109
	K	597,9	28,59						109
0676	A	639,0	30,56	D4	LNTE 100-250/75/4	4	15	7,500	103
	A	636,5	30,44						104
	K	636,3	30,43						104
0706	A	658,6	31,50	D5	LNTE 100-250/75/4	4	15	7,500	95,5
	A	655,3	31,34						96,7
	K	656,5	31,39						96,3
0768	A	721,1	34,49	E1	LNTE 100-160/110/2	2	20	11,00	138
	A	720,4	34,45						138
	K	720,5	34,45						138
0808	A	762,2	36,45	E2	LNTE 100-160/110/2	2	20	11,00	123
	A	760,7	36,38						123
	K	759,5	36,32						124
0848	A	801,1	38,31	E3	LNTE 100-160/110/2	2	20	11,00	131
	A	798,7	38,20						131
	K	798,1	38,17						132
0898	A	839,7	40,16	F1	LNTE 100-160/150/2	2	27	15,00	182
	A	837,2	40,04						183
	K	835,5	39,96						183
0928	A	872,3	41,72	F2	LNTE 100-160/150/2	2	27	15,00	171
	A	868,8	41,55						172
	K	867,1	41,46						172

(1) Values refer to nominal conditions
 CH Cooling mode
 Pf Cooling capacity unit (Cooling mode)
 Pt Heating capacity unit (Heating mode)

Q Plant (side) exchanger water flow
 F.L.I. Pump power input
 F.L.A. Pump running current
 HU Pump residual pressure head (Units with hydronic group without mains filter)

HEAT EXCHANGER USER SIDE - EV - 2 PUMPS 2P LH (VAR SPEED)

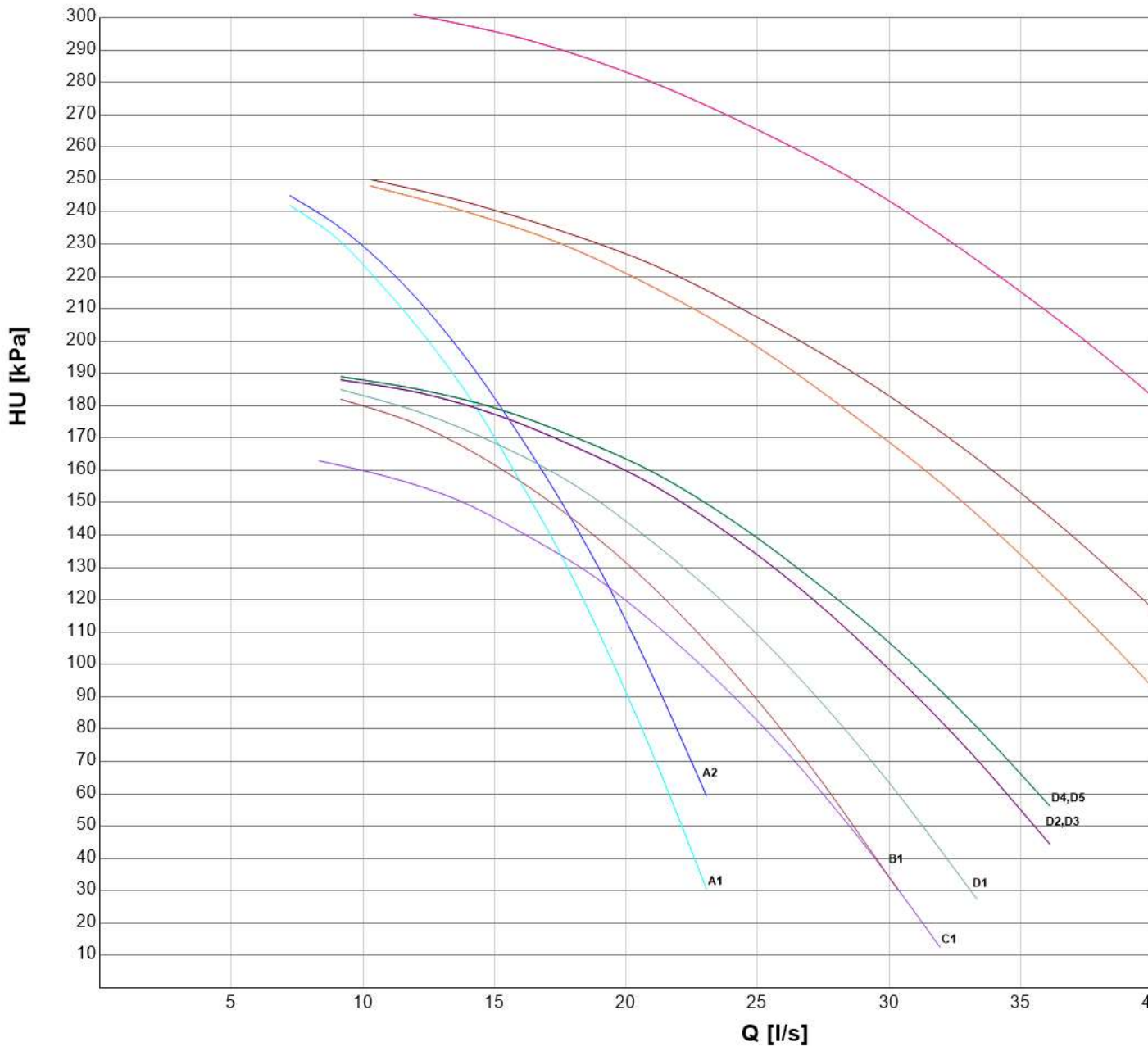

VARIABLE FLOW CONTROL

Pump energy consumption significantly impacts plant running costs, but it can be considerably reduced thanks to the use of variable speed pumps (inverter driven pumps), capable of adjusting the water flow rate according to the actual plant thermal load. Mitsubishi Electric Hydronics & Cooling Systems has developed the VPF control series (Variable Primary Flow), that provides different water flow regulation logics specifically devoted to various hydraulic plant solutions: only a primary circuit, primary and secondary circuits, single

unit or multi-unit systems controlled with external controller (Manager 3000, ClimaPRO) or with 1541, 1542 Multi Manager options. The VPF systems adjust the pump speeds on the basis of the plant's thermal load and optimize the unit's thermoregulation algorithm for variable flow operation, in a dynamic and simultaneous way. This ensures the highest energy savings, stable operation, and complete reliability.

VPF SYSTEM (delta P control) For plants with only a primary circuit

VPF - Plant and unit requirements

The VPF logic provides the variable flow control for the plant's primary circuit.

- Type of plant: primary circuit only, that feeds hydronic terminals fitted with a 2-way regulating valve
- Hydronic module: modulating regulation devices (0-10V signal) or variable speed pumps
- Unit thermoregulation: control of the leaving water temperature
- Monitored parameter: delta P on relevant users' hydronic terminal

Plant diagram for single unit system

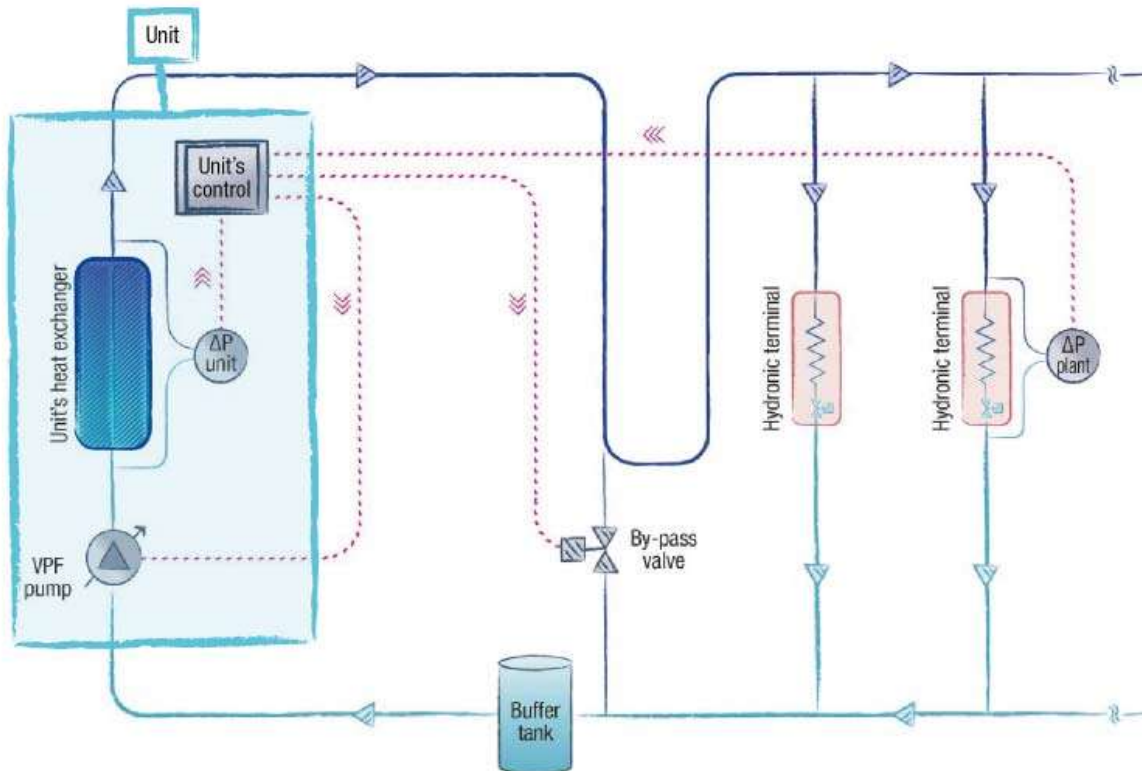

Plant diagram for multi-unit with external control system (Manager3000 or ClimaPRO)

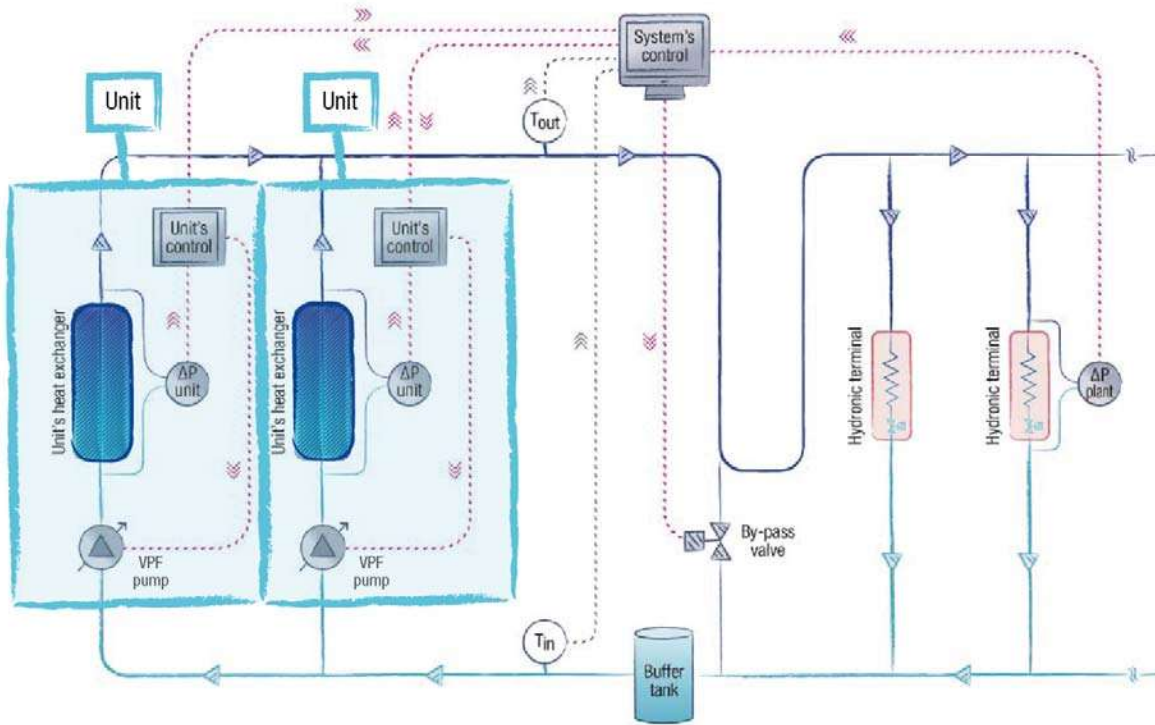

Plant diagram for multi-unit system with Multi Manager

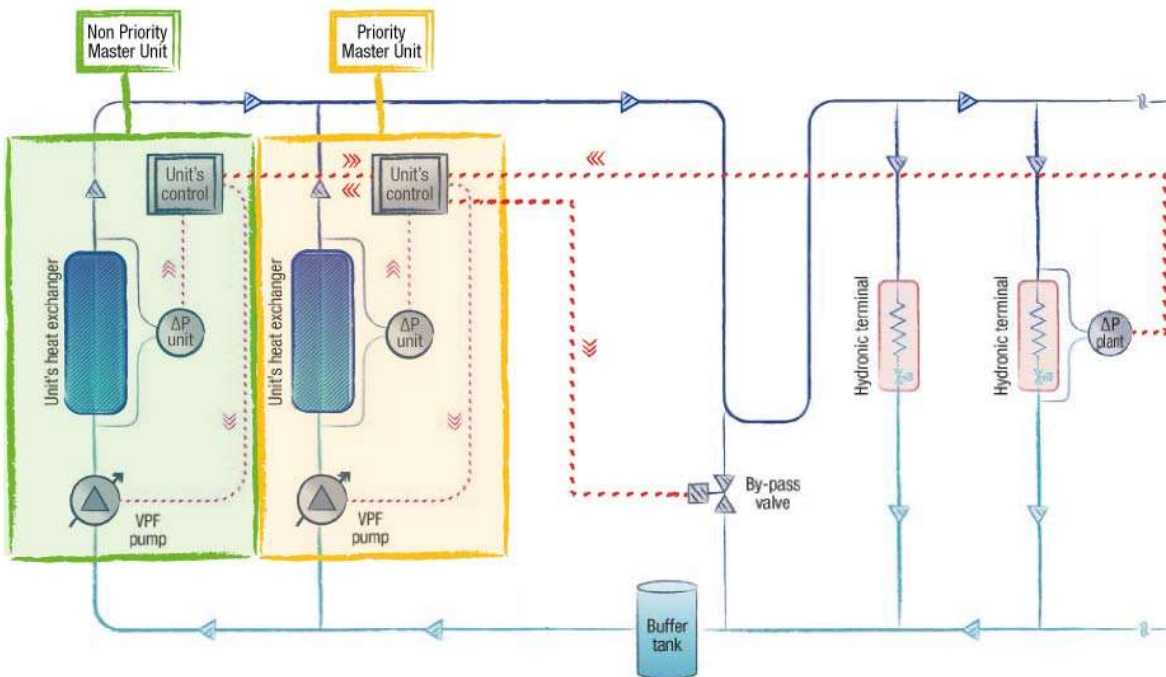

VPF - Operating logic

Water flow regulation

The VPF system monitors the differential pressure on the plant side (ΔP) and adjusts the pump speed in order to keep it within a defined range ($\Delta P_{min} \leftrightarrow \Delta P_{max}$).

- If $\Delta P_{min} \leq \Delta P \leq \Delta P_{max}$

The plant water flow is appropriate to the thermal load, the pump speed is kept constant.

- If $\Delta P > \Delta P_{max}$

The plant water flow exceeds what is necessary to properly cover the thermal load, the pump speed is reduced to save pump energy.

- If $\Delta P < \Delta P_{min}$

The plant water flow is too low to ensure the proper feed to the hydronic terminals, the pump speed is increased.

With the VPF system, the water flow can be reduced to 50% of the unit nominal water flow, with regards to the selection conditions, provided that the minimum water flow required by the unit's heat exchanger is respected (the control of the heat exchanger's minimum water flow is described below).

The pump speed regulation is performed with little progressive adjustments while continuously monitoring the values of both the delta P on the plant side and the water temperature on the heat exchanger. The absence of abrupt water flow changes prevents fluctuation due to possible conflicts with the unit's thermoregulation function (compressor regulation).

Control of the unit's minimum water flow

Under no circumstances can the primary circuit water flow be reduced below the minimum water flow required by the unit's heat exchanger. The monitoring of the unit's water flow is performed through a factory installed differential pressure transducer on the unit's heat exchanger. If the differential pressure on the plant side requests a user's water flow lower than the unit's minimum water flow, the VPF system commands the gradual opening of the hydraulic by-pass valve (safety function). This ensures that the minimum water flow required by the unit's heat exchanger is always provided. As soon as the hydronic terminals request an increase of the water flow ($\Delta P < \Delta P_{min}$), the VPF closes the by-pass valve.

Multi-unit systems

The VPF control logic is also the same for multi-unit systems. The plant side differential pressure transducer reading and the by-pass valve opening are managed by the multi-unit control system (Manager3000, ClimaPRO, Multi Manager Master). Each unit autonomously adjusts its pump speed on the basis of the information provided by the multi-unit control system. When the plant load requests the activation of a stand-by unit, the multi-unit control system calculates the starting speed of its pump in order to avoid excessive water flow variation of the running units.

In case of multi-unit system with Multi Manager, at least one unit must be set as Priority Master (opt 1541). To grant redundancy to the system, more than one unit can be configured as Priority Master. All the Priority Masters must be connected to the differential pressure transducer and the by-pass valve. The Multi Manager system only takes into account the signal read and sent by the Master of the moment (a specific filtering device is part of the supply; see the table below, note (8)).

The Non Priority Master cannot be connected to differential pressure transducer and by-pass valve and cannot manage the VPF function. In the event that a Non Priority Master is elected as the Master of the system, the VPF function is suspended.

VPF - Devices and installation

Device	Accessory name		
	VPF (w/o DP)(SU, MM_PR) ⁽¹⁾	VPF (w DP)(SU, MM_PR) ⁽²⁾	VPF (M3000, CPRO, MM_N-PR) ⁽³⁾
Differential pressure transducer on the unit's heat exchanger and related controller expansion board	Factory installed	Factory installed	Factory installed
Controller expansion board to read the plant side differential pressure transducer (4-20mA signal) and manage the hydraulic by-pass valve opening (0-10V signal)	Factory installed	Factory installed	Factory installed on the multi-unit external control system (Manager3000, ClimaPRO) Not included with option 1542 (Non Priority Master unit) ⁽⁵⁾
Plant side differential pressure transducer	Not included (the supply is the customer's responsibility) ⁽⁴⁾	Factory supplied, installation is the client's responsibility ⁽⁴⁾⁽⁵⁾	Factory supplied with the multi-unit external control system (Manager3000, ClimaPRO); installation is the client's responsibility Not included with option 1542 (Non Priority Master unit) ⁽⁴⁾⁽⁶⁾
Plant side hydraulic by-pass valve	Not included (the supply is the customer's responsibility) ⁽⁷⁾⁽⁸⁾	Not included (the supply is the customer's responsibility) ⁽⁷⁾⁽⁸⁾	Not included (the supply is the customer's responsibility) ⁽⁷⁾

(1) VPF for unit without plant differential pressure transducer included (for single unit plant and Priority Master unit)

(2) VPF for unit with plant differential pressure transducer included (for single unit plant and Priority Master unit)

(3) VPF for multi-unit plant with external controller (Manager3000, ClimaPRO) and Non Priority Master unit

(4) It is recommended to install the differential pressure transducer on the most hydraulically critical hydronic terminal, to ensure it has a proper water flow in any load condition.

(5) Technical features of the differential pressure transducer supplied:

Model: Huba Control 692.9 120071C1

Pressure range: 0 ... + 1 bar

Output: 4-20mA

Electrical connection: DIN EN 175301-803-A (IP 65)

Pressure connection adapters: male threaded G 1/8"

(6) It is the customer's responsibility to configure the multi-unit control system (Manager3000, ClimaPRO or Multi Manager) with option VPF.

(7) See attached table for information on the hydraulic by-pass design.

(8) In case of a multi-unit plant with more than one Master Priority unit (opt 1541) please specify it when emailing our sales. An additional device will be added to manage the multiple signals coming from unit's controller to the by-pass valve.

The following table provides the indications for a correct hydraulic by-pass design.

Heat exchanger minimum flow (m ³ /h) ⁽¹⁾	Minimum by-pass diameter	Minimum by-pass valve diameter	Suggested valve model	Kvs	Suggested actuator model
From 19 to 30	DN50 (2")	DN50 (2")	VVG41.50	40	SKB60
Up to 37	DN65 (2" ½)	DN65 (2" ½)	VVF31.65	49	SKB60
Up to 60	DN80 (3")	DN80 (3")	VVF31.80	78	SKB60
Up to 95	DN100 (4")	DN100 (4")	VVF31.90	124	SKC60
Up to 150	DN125 (5")	DN125 (5")	VVF31.91	200	SKC60
Up to 230	DN150 (6")	DN150 (6")	VVF31.92	300	SKC60

(1) In case of a multi-unit system, the unit with the highest minimum water flow should be the reference.

VPF.D SYSTEM (delta T control)

For plants with primary and secondary circuits separated by a hydraulic decoupler.

VPF.D - Plant and unit requirements

The VPF.D logic provides the variable flow control for the plant's primary circuit.

- Type of plant: primary and secondary circuits separated by a hydraulic decoupler
- Hydronic module: modulating regulation devices (0-10V signal) or variable speed pumps
- Unit thermoregulation: control of the leaving water temperature
- Monitored parameter: delta T on primary circuit

Plant diagram for single unit system

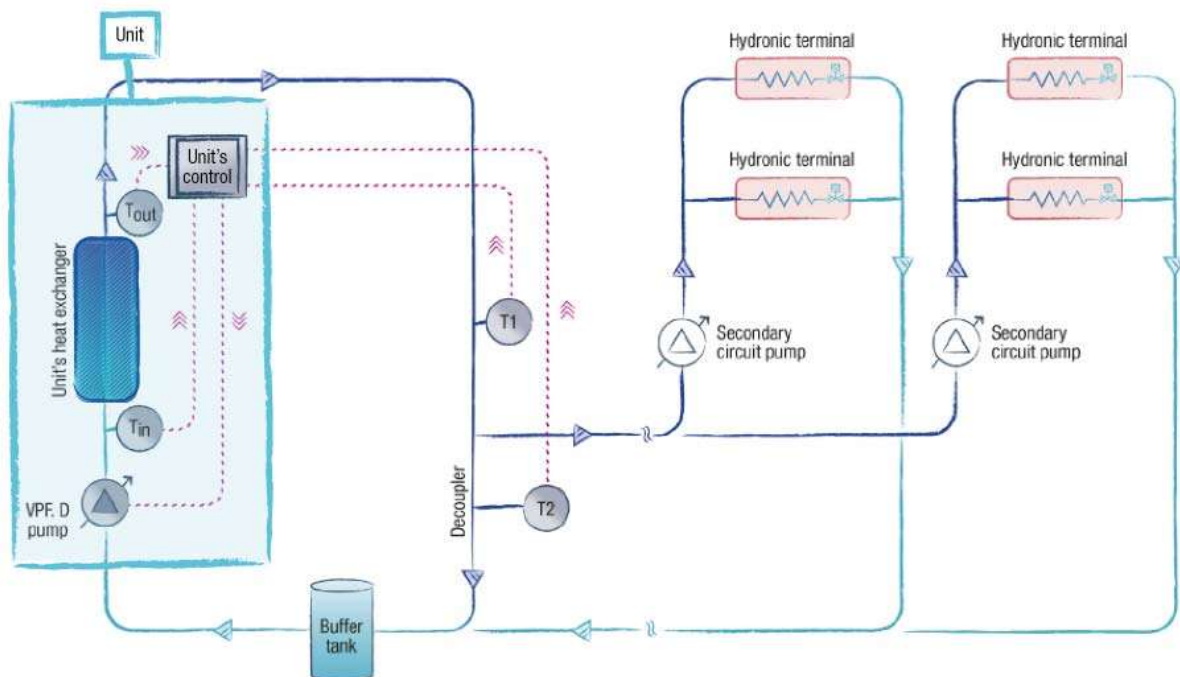

Plant diagram for multi-unit with external control system (Manager3000 or ClimaPRO)

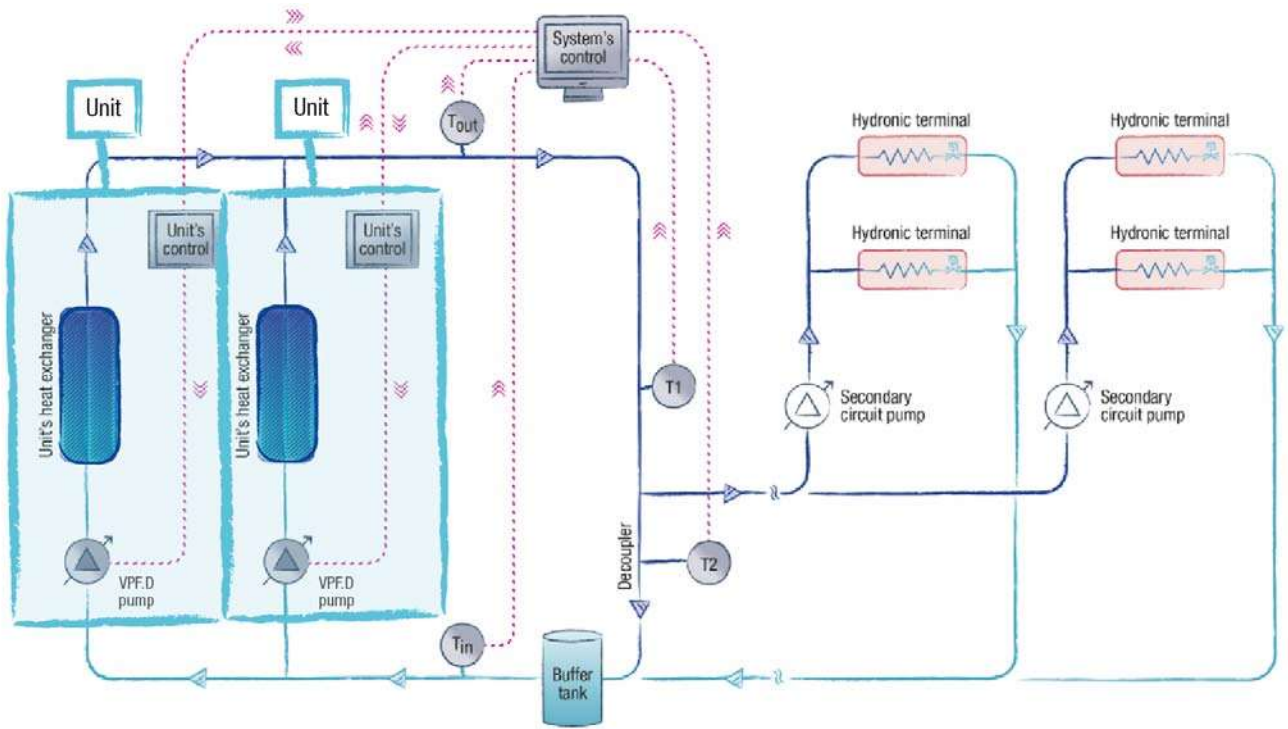

Plant diagram for multi-unit system with Multi Manager

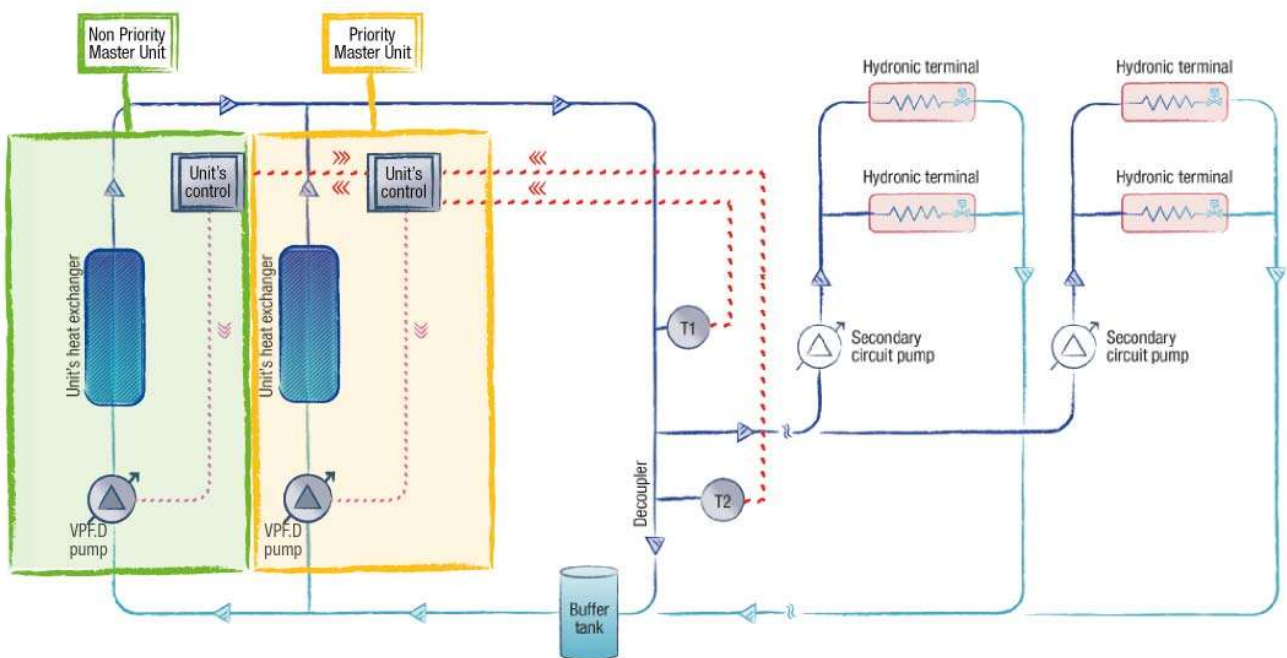

VPF.D - Operating logic

Water flow regulation

The VPF.D system monitors the temperature difference of the primary circuit (ΔT) (that corresponds to the temperature difference of the unit's heat exchanger in the case of a single unit system), and adjusts the primary circuit's pump speed in order to keep it within a defined range ($\Delta T_{min} \leftrightarrow \Delta T_{max}$). The secondary circuit water flow is completely independent and is to be managed by the client.

- If $\Delta T_{min} \leq \Delta T \leq \Delta T_{max}$
The plant water flow is appropriate to the thermal load, the pump speed is kept constant.
- If $\Delta T < \Delta T_{min}$
The plant water flow exceeds what is necessary to properly cover the thermal load, the pump speed is reduced to save pump energy.
- If $\Delta T > \Delta T_{min}$
The plant water flow is too low to ensure the proper feed to the users, the pump speed is increased.

To prevent the returning water of the secondary circuit from recirculating through the decoupler and mixing with the delivery water, which would cause serious plant regulation problems, the VPF.D provides a safety function based on the temperatures, which are detected by two probes on the plant side: T1 on the unit delivery line and T2 on the hydraulic decoupler. If during the water flow regulation of the circuits, the flow direction in the decoupler reverses (detected temperatures $T1 < T2$), the system forces a quick increase of the primary water flow until the correct direction of the flow in the decoupler is restored (detected temperatures $T1 = T2$).

With the VPF.D system, the water flow can be reduced to 50% of the unit nominal water flow, with regards to the selection conditions, provided that the minimum water flow required by the unit's heat exchanger is respected (the control of the heat exchanger's minimum water flow is described below).

The pump speed regulation is performed with little progressive adjustments while continuously monitoring the values of both the temperature difference on the primary circuit and the temperatures of the probes T1 and T2. The absence of abrupt water flow changes prevents fluctuation due to possible conflicts with the unit's thermoregulation function (compressor regulation).

Control of the unit's minimum water flow

Under no circumstances can the primary circuit water flow be reduced below the minimum water flow required by the unit's heat exchanger. The unit's minimum water flow is ensured by setting the minimum pump speed (service menu parameter).

Multi-unit systems

The VPF.D control logic is also the same for multi-unit systems. The reading of the temperature difference on the primary circuit and the reading of the temperature probes T1 and T2 is managed by the multi-unit control system (Manager3000, ClimaPRO, Multi Manager Master).

Each unit autonomously adjusts its pump speed on the basis of the information provided by the multi-unit control system.

When the plant load requests the activation of a stand-by unit, the multi-unit control system calculates the starting speed of its pump in order to avoid excessive water flow variation of the running units.

In case of multi-unit system with Multi Manager, at least one unit must be set as Priority Master (opt 1541). To grant redundancy to the system, more than one unit can be configured as Priority Master. All the Priority Masters must be connected to the temperature probes T1 and T2. The Multi Manager system only takes into account the signal read and sent by the Master of the moment.

The Non Priority Master cannot be connected to the temperature probes T1 and T2, and cannot managed the VPF.D function. In the event that a Non Priority Master is elected as the Master of the system, the VPF.D function is suspended.

VPF.D - Devices and installation

Dispositivo	Accessory name	
	VPF.D (SU, MM_PR) ⁽¹⁾	VPF.D(M3000, CPRO, MM_N-PR) ⁽²⁾
2 plant side NTC temperature sensors and related controller expansion board	Factory supplied (probes supplied without wells), installation is the client's responsibility ⁽³⁾	Factory supplied with the multi-unit external control system, Manager3000 or ClimaPRO (probes supplied without wells); installation is the client's responsibility Not included with option 1542 (Non Priority Master unit) ⁽³⁾⁽⁴⁾

(1) VPF.D for single unit plant and Priority Master unit

(2) VPF.D for multi-unit plant with external controller (Manager3000, ClimaPRO) and Non Priority Master unit

(3) It is recommended to install the temperature probes as shown in the enclosed plant diagrams (T1 on the unit delivery line, T2 on the hydraulic decoupler)

(4) It is the customer's responsibility to configure the multi-unit control system (Manager3000, ClimaPRO or Multi Manager) with option VPF.D.

The following table provides the indications for a correct hydraulic decoupler design.

Heat exchanger minimum flow (m ³ /h) ⁽¹⁾	Minimum hydraulic decoupler diameter
From 25 to 40	DN65 (2" ½)
Up to 60	DN80 (3")
Up to 100	DN100 (4")
Up to 150	DN125 (5")
Up to 225	DN150 (6")
Up to 375	DN200 (8")

(2) In case of a multi-unit system, the unit with the highest minimum water flow should be the reference.



for a greener tomorrow

Eco Changes is the Mitsubishi Electric Group's environmental statement, and expresses the Group's stance on environmental management. Through a wide range of businesses, we are helping contribute to the realization of a sustainable society.



MITSUBISHI ELECTRIC HYDRONICS & IT COOLING SYSTEMS S.p.A.

Head Office: Via Caduti di Cefalonia 1 - 36061 Bassano del Grappa (VI) - Italy
Tel (+39) 0424 509 500 - Fax (+39) 0424 509 509
www.melcohit.com

