

Data Book



NX2-G06 0042 - 0222_202009_EN R454B
ELCA_Engine ver.4.4.5.0

NX2-G06 0042 - 0222

40,1-212 kW

Chiller, air source for outdoor installation



R R454B

SCROLL

P PLATES



(The photo of the unit is indicative and may vary depending on the model)

- ✓ **ErP COMPLIANT 2021**
- ✓ **LOW GWP REFRIGERANT**
- ✓ **ALUMINIUM MICRO-CHANNEL HEAT EXCHANGERS**

- ✓ **INTEGRATED HYDRONIC MODULE**
- ✓ **EXTREMELY SILENT OPERATION**
- ✓ **HIGH EFFICIENCY**
- ✓ **GROUP CONTROLS WITH DYNAMIC MASTER**

CERTIFICATIONS

Product certifications



Voluntary product certifications



Check ongoing validity of certificate:

www.eurovent-certification.com

or

www.certiflash.com

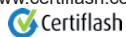

System certifications



MITSUBISHI ELECTRIC HYDRONICS & IT COOLING SYSTEMS S.p.A.

Quality System complying with the requirements of UNI EN ISO 9001:2008 regulation
Environmental Management System complying with the requirements of UNI EN ISO 14001:2004 regulation
Occupational Health and Safety Management System complying with the requirements of BS OHSAS 18001:2007

1.1	PRODUCT PRESENTATION	pg.1.1.1 / 1.1.3
2.1	INCIPIIT	pg.2.1.1 / 2.1.1
3.1	UNIT STANDARD COMPOSITION	pg.3.1.1 / 3.1.3
4.1	OPTIONS	pg.4.1.1 / 4.1.12
5.1	GENERAL TECHNICAL DATA	pg.5.1.1 / 5.1.6
6.1	TECHNICAL DATA SEASONAL EFFICIENCY IN COOLING (EN14825 VALUE)	pg.6.1.1 / 6.1.0
7.1	OPERATING LIMITS	pg.7.1.1 / 7.1.6
8.1	HYDRAULIC DATA	pg.8.1.1 / 8.1.2
9.1	ELECTRICAL DATA	pg.9.1.1 / 9.1.4
10.1	FULL LOAD SOUND LEVEL	pg.10.1.1 / 10.1.3
11.1	DIMENSIONAL DRAWINGS	pg.11.1.1 / 11.1.4
12.1	HYDRONIC GROUP	pg.12.1.1 / 12.1.23

Liability disclaimer

The present publication is drawn up by of information only and does not constitute an offer binding upon Mitsubishi Electric Hydronics & IT Cooling Systems S.p.A.

Mitsubishi Electric Hydronics & IT Cooling Systems S.p.A. has compiled the content of this publication to the best of its knowledge. The data contained herein are subject to change without notice. Mitsubishi Electric Hydronics & IT Cooling Systems S.p.A. explicitly rejects any liability for any direct or indirect damage, in the broadest sense, arising from or related to the use and/or interpretation of this publication. All content is copyrighted by Mitsubishi Electric Hydronics & IT Cooling Systems S.p.A.

The units highlighted in this publication contain R454B [GWP₁₀₀ 466] fluorinated greenhouse gases.

Functions



Cooling

Refrigerant



R454B

Compressors



Scroll compressor

Fan



Axial fan

Exchangers



Plates heat exchanger

Other features



Eurovent



VPF



Electronic Expansion Valve

1.1 PRODUCT PRESENTATION

GREEN CERTIFICATION RELEVANT

Mitsubishi Electric Hydronics & IT Cooling Systems S.p.A., as a major player in the world HVAC market and a leading manufacturer of energy efficient, sustainable HVAC solutions, recognizes and supports the diffusion of green certification systems, as an effective way to deliver high performance buildings and improve the quality and the sustainability of the built environment.

Since the first certification system was introduced at the beginning of the 1990s, the demand for certified buildings has grown considerably, as well as the number of standards, rating and certification programs. Operating worldwide Mitsubishi Electric Hydronics & IT Cooling Systems S.p.A., has extensive experience with many of them and is active member of Green Building Council Italy.

Mitsubishi Electric Hydronics & IT Cooling Systems S.p.A., commitment to develop responsible and sustainable HVAC solutions, is reflected by a full range of premium efficiency products and systems, designed with special care to improve building energy performance ratings, according to major certification protocols, including LEED, BREAM, GREENSTAR, BCA, NABERS, DNGB, HQE and BEAM.

To find out more about how our products contribute to enhanced green certification rating and energy performance of a building, please refer to:

https://www.melcohit.com/EN/Environment/green_certifications/



PRODUCT PRESENTATION

Outdoor unit for the production of chilled water with hermetic rotary Scroll compressors, ozone-friendly refrigerant R454B, axial-flow fans, micro-channel full-aluminum condensing coils, braze-welded plate heat exchanger and electronic expansion valve. The range is composed by units equipped with two compressors in single circuit configuration.

1.3 ErP COMPLIANT 2021

The units comply and exceed the minimum seasonal energy efficiency requirements that will start from 2021, imposed by the eco-sustainable design Directive 2009/125/EC. The seasonal efficiency can be further raised thanks to the optional EC fans from size 0102P.

1.4 LOW GWP REFRIGERANT

The new generation refrigerant R454B is the most eco-sustainable alternative to traditional refrigerant R410A, offering a 76% reduction in terms of GWP (Global Warming Potential GWP of R454B = 467, GWP of R410A = 1924 as per IPCC rev. 5th) and zero impact on the ozone layer.

1.5 ALUMINIUM MICRO-CHANNEL HEAT EXCHANGERS

The full aluminium micro-channel condenser coils deliver high efficiency while ensuring a reduced refrigerant volume and a lower unit weight. The e-coating protection (optional) grants the highest level of corrosion resistance in any condition, even in the most aggressive environments.

1.6 INTEGRATED HYDRONIC MODULE

The built-in hydronic module already contains the main water circuit components; it is available as option with single or twin in-line pump, for achieving low or high head, fixed or variable speed and buffer tank.

1.7 EXTREMELY SILENT OPERATION

The best compromise between silence and efficiency, as result of a systematic design oriented to minimize noise levels.

1.8 HIGH EFFICIENCY

Very high efficiency at full and partial loads, at the highest market levels, thanks to the adopted technological solutions. These units ensure low operating costs and therefore a quick payback time.

1.9 GROUP CONTROLS WITH DYNAMIC MASTER

Load sharing, sequencing, active redundancy, priority of resource activation, alarm management, these are only some of the LAN functions that the unit is able to manage when connected to a group of chillers. Besides, the system's stability is ensured even in case of alarm or malfunctioning thanks to the Dynamic Master logic.

1.10 VARIABLE PRIMARY FLOW

Energy savings due to variable pump speed management based on load demand and the variable flow ensures the units also function in critical working conditions.

NX2-G06 / D / 0222

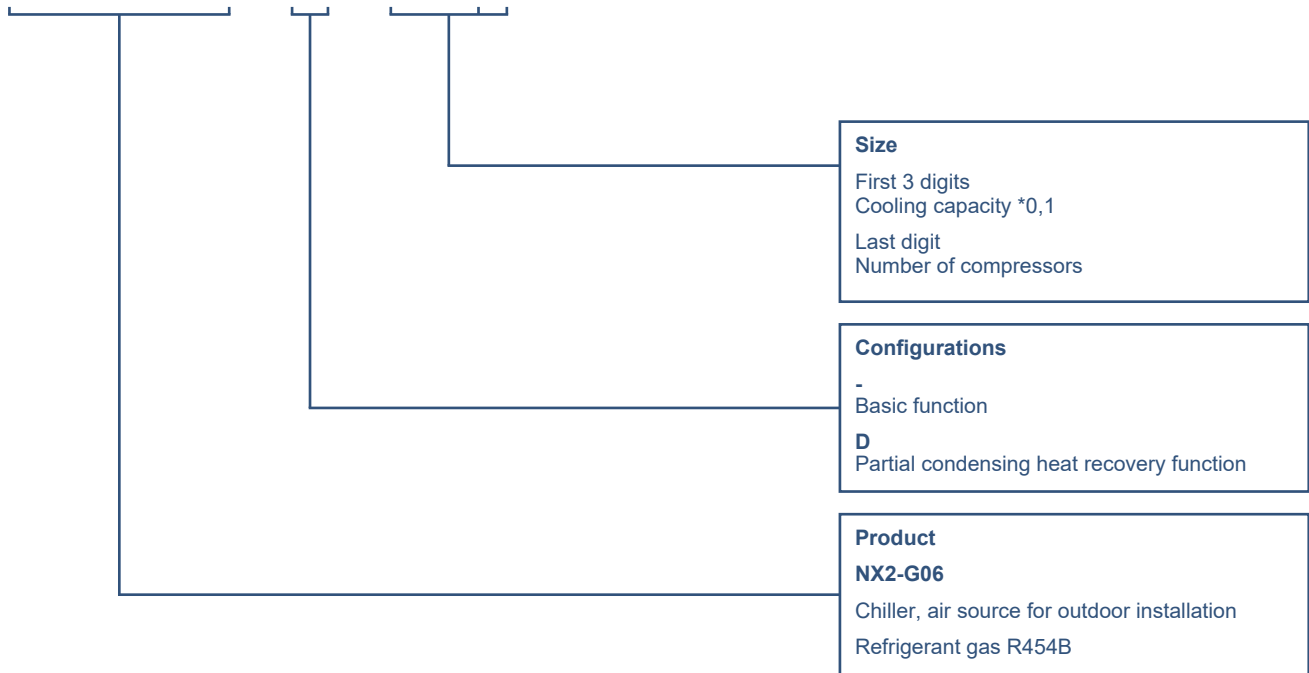

3.1 UNIT STANDARD COMPOSITION

CONFIGURATIONS

- , standard unit

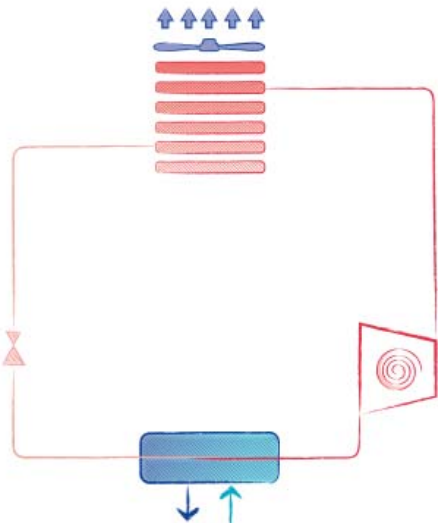

No heat recovery is possible.

/D, unit with partial heat recovery

Heat recovery: ON

Heat recovery: OFF (water flow stopped)

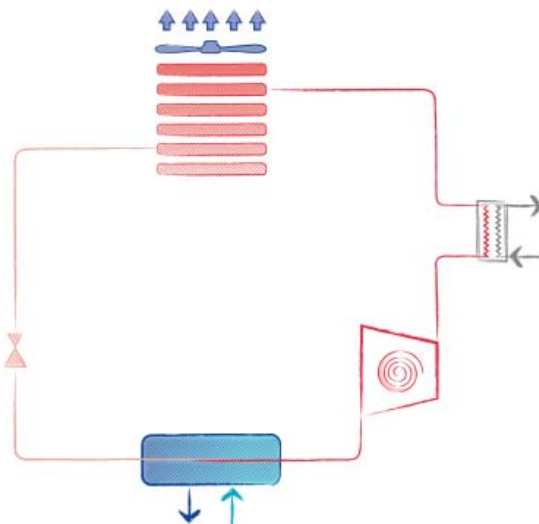
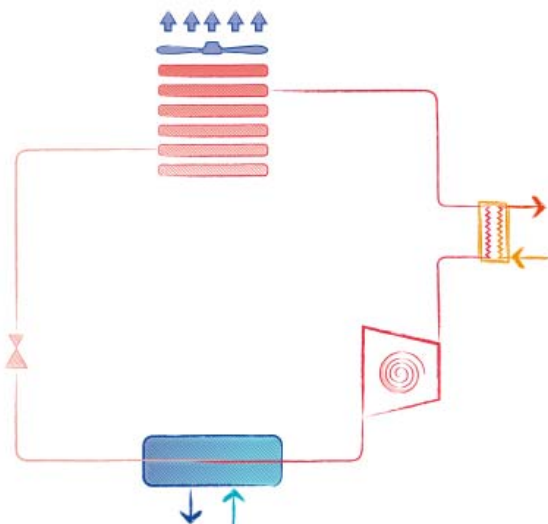

Each refrigerant circuit is fitted with a desuperheater.

The superheating heat recovery is only possible when the temperature of the hot water circuit is lower than the compressor discharge temperature. The heat recovery and its amount depends on the unit's operating conditions, in particular the outdoor air temperature and the load percentage. It is advised to interrupt the water flow to the desuperheater when the conditions for an actual heat recovery are not met.

The smart management of the desuperheater pump(s) is possible with the option 3371 D – RELAY 1 PUMP (ON/OFF), further information is available in the bulletin section dedicated to accessories.

Partial heat recovery operating limits:

	MIN temperature	MAX temperature
Inlet water	25°C (77°F)	56°C (132,8°F)
Outlet water	30°C (86°F)	60°C (140°F)

UNIT STANDARD COMPOSITION

3.2 Chiller, air source for outdoor installation

Outdoor unit for the production of chilled water with hermetic rotary Scroll compressors, ozone-friendly refrigerant R454B, axial-flow fans, micro-channel full-aluminum condensing coils, braze-welded plate heat exchanger and electronic expansion valve. The range is composed by units equipped with two compressors in single circuit configuration.

- The unit is supplied fully refrigerant charged and factory tested. On site installation only requires power and hydraulic connection.

3.3 Structure

Structure specifically designed for outdoor installation. Base and frame in hot-galvanised steel sheet of suitable thickness. All parts polyester-powder painted to assure total weather resistance. Painting: RAL 7035 textured finish. The self-supporting frame is built to guarantee maximum accessibility for servicing and maintenance operations.

3.4 Refrigerant circuit

Unit designed with 2 compressors in a single refrigerant circuit optimizing the heat exchange's process, especially in part load mode. The units feature an internally designed, patent-pending device, able to optimize the thermodynamic cycle.

In addition to the main components described in the following sections, the refrigerant circuit is fitted as standard with:

- drier filter (with replaceable cartridge from size 0102)
- refrigerant line sight glass with humidity indicator
- safety switching device for limiting the pressure
- liquid line shut-off valve (only on sizes with drier filter with replaceable cartridge, from sizes 0102)
- high and low pressure transducers
- electronic expansion valve
- Liquid line solenoid valve
- High and low pressure safety valve
- visualization of the pressure's level directly from the controller's interface
- Antifreeze electric heater for heat exchanger
- crankcase heater on each compressor

3.5 Compressor

Hermetic scroll compressors complete with an oil sump heater, electronic overheating protection with centralised manual reset and a two-pole electric motor.

3.6 Plant side heat exchanger

Braze welded AISI 316 plate heat exchanger. The heat exchanger is lined on the outside with 9 mm thick closed-cell neoprene lagging to prevent condensation, with a thermal conductivity of 0,33 W/mK at 0°C. The heat exchanger is fitted with a differential pressure switch to monitor the correct flow of water when the unit is operating, thus preventing ice form forming inside; if no flow is detected, the frost protection function is activated using a special heater.

3.7 Source side heat exchanger

Microchannel coils ideally positioned on an open-angle Longitudinal V-shaped structure to optimize airflow and heat transfer. Made entirely in aluminum, the coils are not subjected to galvanic corrosion.

Fins and manifolds are made of aluminum AA3003, while the channels are made of a new aluminum alloy so defined Long Life Alloy (LLA). LLA alloy has a very fine grain microstructure that guarantees higher mechanical properties and a higher resistance to the inter-granular corrosion.

3.8 Features of the optional silenced units

Units with optional "compressor soundproofing insulation" feature:

- Compressor enclosure with soundproofing insulation in polyester fiber mat (thickness of 30 mm)
- If the hydronic is present, the pump enclosure is acoustically insulated: 30 mm thick Fiberform (polyester fibres)

Units with optional "NR kit" (Noise Reducer kit) feature:

- Reduced fan speed (the fan speed is automatically increased in case of particularly tough environmental conditions)
- Compressor enclosure with soundproofing insulation in polyester fiber mat (thickness of 30 mm) and compressor sound jackets
- If the hydronic is present, the pump enclosure is acoustically insulated: 30 mm thick Fiberform (polyester fibres)

3.9 Electrical and control panel

Electrical and control panel built to EN60204-1 and EC204-1 standards, complete with:

- Electronic control W3000+
- electric circuit breakers for compressors and fans
- terminals for cumulative alarm block

- remote ON/OFF terminals
- general door lock isolator
- numbered cables
- Outdoor air temperature probe
- Pump control relay + 0-10V modulating signal to control an external variable speed pump with the VPF.E control logic (plant-side constant ΔT for plants with primary circuit only and terminals with bypass)
- control circuit transformer
- spring-type control circuit terminal board
- Phases sequence control
- auxiliary 4-20mA analogue input
- Power supply 400V/3ph/50Hz+N+PE for units:
 - from size 0042 to size 0092
- Power supply 400V/3ph/50Hz+PE for units:
 - from size 0102 to size 0222

3.10 Fan section source side

Axial electric fans protected to IP54 and with insulation class 'F', featuring an external rotor and profiled blades. Housed in an aerodynamic hood complete with safety guard. The fan + outlet set satisfies the efficiency requirements provided for by EcoDesign directive 327/11.

Fans diameter: 450 mm from size 0042P to 0092P; 800 mm from size 0102P to 0222P.

4-pole ($\varnothing 450$ fans) or 6-pole ($\varnothing 800$ fans) electric motor with built-in thermal protection. Condensation control with adjustment of the fan speed with single fractioning (DVVF with phase-cut device for $\varnothing 450$ fans, DVVF with autotransformer for $\varnothing 800$ fans).

- EC fans (available as option): Axial electronically commutated fans (EC fans), with external rotor, profiled die-cast aluminium blades, housed in aerodynamic hoods complete with guard grille. The brushless motor, governed by a special controller, continuously adjust fans' speed to minimize energy consumption, electromagnetic noises and current's absorption even during start-up phase.

3.11 Certification and applicable directives

The unit complies with the following directives and relative amendments:

- CE Declaration of conformity certificate for the European Union
- 2014/35/EC Low Voltage Directive
- 2014/30/EC EMC Directive
- ErP Directive 2009/125/EC
- Machinery Directive 2006/42/EC
- PED Directive 2014/68/EC
- EAC Product quality certificate for Russian Federation
- ISO 14001 Company Environmental Management System certification
- ISO 9001 Company Quality Management System certification

3.12 Tests

Tests performed throughout the production process, as indicated in ISO9001.

Performance or noise tests can be performed by highly qualified staff in the presence of customers.

Performance tests comprise the measurement of:

- electrical data
- water flow rates
- working temperatures
- power input
- power output
- pressure drops on the water-side exchanger both at full load (at the conditions of selection and at the most critical conditions for the condenser) and at part load conditions.

During performance testing it is also possible to simulate the main alarm states.

Noise tests are performed to check noise emissions according to ISO9614.

3.13 Electronic control W3000+

W3000+ features an easy-to-use interface and a complete LCD display that allows one to consult and intervene by means of a multi-language menu (19 languages are available). The diagnostics includes a complete alarm management, with the "black-box" and the alarm history display for enhanced analysis of the unit operation. The programmable timer manages a weekly schedule organized into time bands to optimize unit performance by minimizing power consumption during periods of inactivity. Up to 10 daily time bands can be associated with different operating set points. As option, KIPLink is available - Keyboard In Your Pocket. KIPLink is the innovative user interface based on WiFi technology that allows one to operate on the unit directly from the smartphone or tablet.

The regulation is based on the patented "Quickmind" water temperature regulation logic uses self-adapting control to maintain flow temperatures

UNIT STANDARD COMPOSITION

and optimize performance even in low water content scenarios. As an alternative, the proportional or proportional-integral regulations are also available.

Optional proprietary devices can perform the adjustment of resources in systems made of several units. Consumption metering and performance measurement are possible as well. The variable primary flow control is always available as per standard (VPF.E function).

Supervision can be easily developed via proprietary devices or the integration in third party systems by means of the most common protocols as ModBus, Echelon, Bacnet-over-IP, Bacnet MS/TP RS485, Konnex, ModBus TCP/IP, SNMP. Compatibility with the remote keyboard (up to 8 units).



3.13 KIPlink - Keyboard In your Pocket (option 6196)

KIPlink - Keyboard In Your Pocket - is the innovative user interface based on WiFi technology that allows one to operate on the unit directly from the smartphone or tablet. Using KIPlink, it is possible to turn the unit on and off, adjust the set-point, plot the main operating variables, monitor in detail the status of the refrigerant circuits, the compressors, the fans (if present) and the pumps (if present) and display and reset the possible alarms.



3.13 Night mode (option 1430)

The night mode function allows to reduce the sound power of the unit, reducing the speed of the fans and the number of active compressors.

3.13 U.L.C. - User limit control (option 4960)

Guaranteed the start-up of the units with the option U.L.C. even when the critical working condition could generate an alarm.

The controller can manage a 3way mixing valve (not provided) by 0-10V signal for ensuring a dynamic control of the water temperature on user heat exchanger according to the operating limits allowed. This ensures the start-up and correct functioning of the unit into the envelope, also even critical whether condition.

3.13 LAN Multi Manager (option 1540)

Up to 8 units (chillers or free-cooling chillers, with the same firmware version) can communicate via serial connection.

All the group functions are implemented with master/slave logic, with dynamic master.

Hereunder is a brief description of the main group functions, further details are available in the dedicated user manual.

- Load management

There are two possible load management logics: load sharing and sequencing.

- Load sharing: the load is distributed equally among the active units of the group.

- Sequencing: the units are activated one after the other. When the first unit is saturated (all the available resources are used), the second unit is activated, and so forth until the load is fully covered.

- Dynamic master

In case of disconnection of the master unit, a new master is automatically elected among the other units, and the group functions remain active. The dynamic master function grants a backup solution to the net, overcoming the single point of failure typical of the static master architecture. Besides, it is possible to set the "master succession priority": in case of the master unit disconnection, the new master is elected among the units set as priority.

- Stand-by unit management

It is possible to set the number of unit that remain in stand-by, the load will be managed (with load sharing or sequencing) among the other units of the group. The stand-by unit rotation is automatic, according to the running hours equalization. A stand-by unit is immediately activated in case of total failure or disconnection of one of the active units of the group, or in case the water temperature exceeds the safety threshold.

- Restart in sequence

After a power black-out, this group function coordinates the compressor activation time of the different units and prevents from dangerous current picks due to simultaneous start-ups. Besides, it is possible to set the activation sequence of the units.

- Resource priority management

To make the most of the available cooling resources, it is possible to set the usage priority of each unit. The load management function will be adjusted accordingly. When available, the free-cooling is always given priority and is fully exploited before activating any compressor. Then the activation of the compressors follows the priority level assigned to the units.

- Auxiliary input

The auxiliary inputs are applied at a group level:

- 4-20 mA: remote set-point adjustments (analog input).

- Double set-point: remote switch between 2 set-points (digital input).

- Demand limit: remote signal to limit the unit's activable resources (digital input).

3.14 Versions

- Standard Version

Key efficiency units grant the best cooling capacity/footprint ratio.

3.15 Configurations

/D, unit with partial heat recovery

Unit for the production of chilled water, equipped with an auxiliary heat exchanger (desuperheater) on the compressor discharge for superheat recovery. The recovered heat is approximately the 20% of the total cooling capacity and can be used for domestic hot water production or other secondary uses, such as the integration of an existing boiler.

4.1 OPTIONS

OPTIONS	DESCRIPTIONS	BENEFITS	AVAILABLE FOR MODELS
2280 EQUIPMENT KIT:			
2281 UP KIT	The dedicated unit components setting permits a significant energy efficiency increase.	This option boosts the unit's energy efficiency at both full and part load.	ALL
2282 NR KIT	The option includes the fan speed reduction and the compressors' acoustical enclosure	The dedicated fans' speed calibration together with the soundproofing of the most critical components permit a significant noise reduction.	ALL
1440 USER INTERFACE			
1441 KIPLink + COMPACT KEYBOARD	In addition to KIPLink, the innovative user interface based on WiFi technology, the unit is equipped with the Compact keyboard with LCD display and buttons.		ALL
6196 KIPLink	The unit is equipped with KIPLink, the innovative user interface based on WiFi technology		ALL
6310 VISUAL DISPLAY PROTECTION			
6311 WITH DISPLAY PROTECTION	Display protection sealed panel	Provide complete protection against UV rays, atmospheric agents, sand storms.	ALL
380 NUMBERED WIRING			
382 PWR WIRINGS ACC.TO UK REQUEST		Facilitate maintenance interventions to the electrical board connections.	ALL
383 NUMBERED WIRINGS+UK REQUESTS	Electrical board wires are identified by numbered labels. The reference numbers are indicated in the unit's wiring scheme.	Facilitate maintenance interventions to the electrical board connections.	ALL
3410 AUTOMATIC CIRCUIT BREAKERS			
3412 AUTOM. CIRCUIT BREAK. ON LOADS	Over-current switch on the major electrical loads.	In case of overcurrent allows resetting of the switch without the replacement of relative fuses.	ALL
2410 PHASE SEQUENCE RELAY			
2411 WITH EXTERNAL PHASE SEQUENCE RELAY	Relay for checking mains phase-sequence	Protects loads against faults due to incorrect connection of mains	ALL
2412 PHASE SEQU. RELAY + OVER/UNDER VOLT. MONIT.	Relay for checking mains phase-sequence and voltage	The monitoring relay protects loads against faults due to incorrect connection of mains, and it monitors whether it exceeds or falls below a specified voltage in a three-phase network.	ALL
3600 COMPRESSOR RUN STATUS SIGNAL			
3601 COMPRESSOR OPERATION SIGNAL	Auxiliary contacts providing a voltage-free signal.	Allows remote signalling of compressor's activation or remote control of any auxiliary loads.	ALL
6160 AUXILIARY INPUT			
6161 AUXILIARY SIGNAL 4-20mA	4-20 mA analog input	Allows to change the operating set-point according to the value of current applied to the analogue input.	ALL
6170 DEMAND LIMIT			
6171 INPUT REMOTE DEMAND LIMIT	Digital input (voltage free)	It permits to limit the unit's power absorption for safety reasons or in temporary situation.	ALL

OPTIONS

OPTIONS	DESCRIPTIONS	BENEFITS	AVAILABLE FOR MODELS
4500 FAST RESTART (UPS EXCLUDED)			
4501 FAST RESTART (UPS EXCLUDED)	Unit fast restart management after power failure	The management of the fast restart allows to minimize downtimes in case of power failure, keeping all the necessary unit safeties. This option requires an external 203V AC 300VA UPS power supply, by customer.	ALL
1510 SOFT-STARTER			
1511 UNIT WITH SOFT-START	Electronic device adopted to manage the inrush current. The device controls 2 phases.	Break down of the inrush current compared to the direct motor start, lower motor windings' mechanical wear, avoidance of mains voltage fluctuations during starting, favourable sizing for the electrical system.	ALL
3300 COMPRESSOR REPHASING			
3301 COMPR.POWER FACTOR CORR.	Capacitors on the compressors' power inlet line.	The unit's average cos(phi) increases.	ALL
4180 REMOTE CONNECTION ARRANGEMENT			
4181 SERIAL CARD MODBUS	Interface module for ModBUS protocols.	Allows integration with BMS operating with ModBUS protocol.	ALL
4182 SERIAL CARD FOR LONWORKS	Interface module for Echelon systems.	Allows integration with BMS operating with LonWorks protocols	ALL
4184 SERIAL CARD BACNET MS/TP RS485	Interface module for BACnet protocols.	Allows integration with BMS operating with BACnet protocol.	ALL
4185 SERIAL CARD FOR BACNET OVER IP	Interface module for BACnet OVER-IP protocols.	Allows to interconnect BACnet devices over Internet Protocol within wide-area networks.	ALL
4186 SERIAL CARD FOR KONNEX	Protocol for KNX system	Allows integration with BMS operating with KNX protocol	ALL
4187 M-Net W3000 INTERFACE KIT	Interface kit for M-Net protocol.	Interface module to allow the integration of the unit with Mitsubishi Electric proprietary communication protocol M-Net.	ALL
4188 SERIAL CARD MODBUS TCP/IP	Interface module for ModBus TCP/IP protocol	Allows integration with BMS operating with ModBus TCP/IP protocol.	ALL
4189 SERIAL CARD SNMP	Interface module for SNMP protocol	Allows integration with BMS operating with SNMP protocol.	ALL
1470 MULTIFUNCTION CARD			
1431 NIGHT MODE	The option includes a related controller expansion board and dedicated terminal block.	Night mode is a system setting to limit maximum noise level of the unit. Noise level is reduced limiting maximum compressor frequency and fan speed.	ALL
1471 4951 + 1431	The option includes a related controller expansion board and dedicated terminal block.	Enables the functions corresponding to the indicated accessory codes.	ALL
1472 4951 + 1431 + 4961	The option includes a related controller expansion board and dedicated terminal block (it is necessary to install a 3 way valve).	Enables the functions corresponding to the indicated accessory codes.	ALL
1473 4951 + 4961	The option includes a related controller expansion board and dedicated terminal block (it is necessary to install a 3 way valve).	Enables the functions corresponding to the indicated accessory codes.	ALL

OPTIONS

OPTIONS	DESCRIPTIONS	BENEFITS	AVAILABLE FOR MODELS
1474 1431 + 4961	The option includes a related controller expansion board and dedicated terminal block (it is necessary to install a 3 way valve).	Enables the functions corresponding to the indicated accessory codes.	ALL
4951 WITH HYDRAULIC DECOUPLER PROBE	Water temperature probe on hydraulic decoupler.	The pump activation can be set by parameter according to the water temperature on buffer tank measuring by the sensor (in the systems with the primary and secondary circuits separated by a hydraulic decoupler), thus bringing significant pump consumption reduction during unit's stand-by.	ALL
4961 U.L.C.F. - WITH OR WITHOUT FIX SPEED PUMP	Option to be selected with the unit without pump/s or with fix speed pump/s (4703,4706,4707,4711,4712). The option includes a related controller expansion board and dedicated terminal block.	Guaranteed the start-up of the units with the option U.L.C. even when the critical working condition could generate an alarm. The W3000+ controller can manage a 3 way mixing valve (not provided from MEHITS) by 0-10V signal for ensuring a dynamic control of the water temperature on user heat exchanger according to the operating limits allowed. This ensures the start-up and correct functioning of the unit into the envelope, also even critical whether condition.	ALL
1540 ON BOARD MULTI MANAGER			
1541 MM PRIORITY MASTER MM_PR	Multi Manager - Priority Master: integrated control of a group of chillers and chillers with free-cooling with up to 8 units with LAN logics and dynamic master. The unit is identified and parameterized as a Priority Master; therefore it is given preference in case of election of a new Master (in case of a failure of the current Master). At least one Priority Master must be present in the group. The maximum number of Priority Master units coincides with the number of connected units (up to 8). If you want to equip the group of chiller with auxiliary functions (e.g. 4-20 mA set point variation, pressure transducer for VPF system), each Priority Master requires auxiliary input signals. Consequently, for each Priority Master it is necessary to select these accessories from the price list and proceed with their wiring onsite. More details can be found in the data book and in the controls technical documentation.	It allows the management of a group of chillers and chillers with free-cooling (up to 8 units) via LAN with master/slave operating logic with dynamic master which always guarantees a back-up function to the network. The system makes other functions available such as load and stand-by unit management, resource use priority, unit start-up in sequence and group fast restart (when Fast Restart option is available). For more details refer to the dedicated section of the data book.	ALL
1542 MM NON PRIORITY MASTER MM_N-PR	Multi Manager - Non Priority Master: integrated control of a group of chillers and chillers with free-cooling with up to 8 units with LAN logics and dynamic master. The unit is identified and parameterized as a Non-Priority Master. Non-Priority Master units can become Masters (in case of a failure of the current Master) if there are no more Priority Master units available. In this case, the functions provided by the auxiliary signals are suspended (e.g. 4-20 mA set point variation, VPF); these signals can only be processed by Priority Master units. More details can be found in the data book and in the controls technical documentation.	It allows the management of a group of chillers and chillers with free-cooling (up to 8 units) via LAN with master/slave operating logic with dynamic master which always guarantees a back-up function to the network. The system makes other functions available such as load and stand-by unit management, resource use priority, unit start-up in sequence and group fast restart (when Fast Restart option is available). For more details refer to the dedicated section of the data book.	ALL

OPTIONS

OPTIONS	DESCRIPTIONS	BENEFITS	AVAILABLE FOR MODELS
5920 MANAGEMENT & CONTROL SYSTEMS			
5922 ClimaPRO ModBUS RS485 - MID	This option includes the following devices on-board the unit panel: - MID certified network analyzer operating on ModBUS over RS-485 - Current transformers - Software release LA09 or later version.	This accessory allows to acquire the electrical data and the power absorbed by the unit and communicate with ClimaPRO via high level communication interface based on ModBUS over EIA RS-485. More specifically, the data collected are: power supply, current, frequency, power factor ($\cos\phi$), electrical power consumption, energy consumption. This specific energy meter model is MID certified and can therefore be used for billing applications. This option also ensures the compatibility between the units and ClimaPRO, thus allowing ClimaPRO to acquire all the main unit's operating variables and status by means of a high level communication interface to the controller installed onboard the unit panel.	ALL
5923 ClimaPRO BacNET over IP	This option includes the following devices on-board the unit panel: - network analyzer operating on BACnet over IP - Current transformers - Software release LA09 or later version.	This accessory allows to acquire the electrical data and the power absorbed by the unit and communicate with ClimaPRO via high level communication interface based on BACnet over IP. More specifically, the data collected are: power supply, current, frequency, power factor ($\cos\phi$), electrical power consumption, energy consumption. This network analyzer is not MID certified and cannot therefore be used for billing applications. This option also ensures the compatibility between the units and ClimaPRO, thus allowing ClimaPRO to acquire all the main unit's operating variables and status by means of a high level communication interface to the controller installed onboard the unit panel.	ALL
5924 ENERGY METER FOR BMS	This option includes the following devices on-board the unit panel: - network analyzer with display operating on ModBUS protocol over RS-485 (without certification MID) - current transformers.	This accessory allows to acquire the electrical data and the power absorbed by the unit and send them via RS-485 bus to the BMS for energy metering.	ALL
5925 ENERGY METER FOR W3000	This option includes all following devices on-board the unit panel: - network analyzer with display, already cabled to unit's controller - current transformers.	This option allows to acquire the electrical data and the power absorbed by the unit. The figures are accessible through the unit's W3000 interface, and be sent to the BMS via several protocols by selecting the dedicated serial card in the option list.	ALL
3430 REFRIGERANT LEAK DETECTOR			
3431 REFRIG. LEAK DETECTOR	Refrigerant leak detection system, supplied factory mounted and wired in the electrical board. In case of leak detection it will raise an alarm.	It promptly detects gas leakages	ALL
3433 GAS LEAK CONTACT + COMPR. OFF	Refrigerant leak detection system, supplied factory mounted and wired in the electrical board. In case of leak detection it will raise an alarm and stop the unit.	It promptly detects gas leakages and stops the unit	ALL

OPTIONS

OPTIONS	DESCRIPTIONS	BENEFITS	AVAILABLE FOR MODELS
5940 SETP. COMPENSATION OUT. TEMP.			
5941 WITH SETPOINT COMPENSATION	This option includes an outside air sensor to be installed outside the building and enable the climatic curve function.	An outside air temperature probe, available as option, controls the system water temperature set point based on heating and cooling (reversible units) climatic curves. Delivering water at different temperatures to the terminals based on the outside air temperature achieves high seasonal efficiency ratios and provides considerable savings in running costs.	ALL
3390 ANTICONDENSATE HEATER EL.BOARD			
3391 ELECTRIC HEATER ON EL. BOARD	Electrical heater fed directly from the unit, is automatically activated at temperatures internal QE below 30 ° C (off state at T higher than 40 ° C).	It avoids the risk of humidity condensation on the electrical panel.	ALL
990 CONDENSING COIL			
876 E-COATING MICROCHANNEL COILS	The heat exchanger is completely treated by electrolysis so as to create a protective layer of epoxy polymer on the surface, with the following characteristics: - over 3120 hours of salt spray protection as per ASTM G85-02 A3 (SWAAT); - polyurethane surface protection against UV rays.	Provides a very high resistance against corrosion, also in very aggressive environments. For further information please refer to the Guidelines "Finned coil heat exchangers and protection against corrosion", available in the download section of the website www.melcohit.com/EN/Download/Corporate/GUIDELINES or contact our sales department.	ALL
820 FAN CONTROL			
808 EC FANS	Electronically commutated fans (EC fans). The brushless motor, governed by a special controller, continuously adjust fans' speed.	Reduced energy consumption and minimized current's absorption during start-up phase. The efficiency is increased by approximately: +1% of EER and +4/5% of ESEER. The noise reduces proportionally to the unit's partialization.	ALL
818 OVERSIZED EC FANS	Fans with oversized EC motor	Extends the operating limits of the unit. Further information in the dedicated databook section.	ALL
821 DVV2F	Fan speed control according to the condensing pressure; the use of this device is mandatory in case the unit operates with low evaporator leaving water temperature combined with low outdoor air temperatures	Extension of the unit operating range (see the section dedicated to the operating limits). The device allows the unit to operate in the most extreme conditions avoiding any risk of low pressure alarm intervention. The enhanced air flow management delivers also benefits in terms of both efficiency and quietness.	ALL
1400 HP AND LP GAUGES			
1401 HP AND LP GAUGES	High and low pressure gauges	Allows immediate reading of the pressure values on both low and high pressure circuits	ALL
5040 COMPRESSOR SUCTION AND DISCHARGE VALVE			
5042 COMPRESSOR SUCTION AND DISCHARGE VALVE	Shut-off valve on compressor's suction and discharge circuit.	Simplifies maintenance activities	ALL
1960 PRESSURE RELIEF VALVES			
1961 DUAL RELIEF VALVES WITH SWITCH	Dual relief valve with switch	Allows to unselect a relief valve in order to service the unit avoiding medium or long inoperative periods	ALL
2660 HEAT-EXCHANGER INSULATION			
2641 EXTRA INSULATATION ON EXCHANGERS	Increased thermal insulation on the heat exchanger: 20 mm thick closed-cell expanded polyurethane.	Reduces heat losses and prevent from condensate problems.	ALL

OPTIONS

OPTIONS	DESCRIPTIONS	BENEFITS	AVAILABLE FOR MODELS
4700 EV - HYDRONIC MODULE			
4706 EV - 1 PUMP 2P LH (FIX SPEED)	Evaporator hydronic module, compatible with constant flow control. The unit is provided with 1 fixed speed pump, with 2-pole motor. Residual head of 100 kPa approximately. Specifications and characteristic curves are available in the dedicated bulletin section.	The hydronic module includes the pumps and the main water circuit components, thus optimizing hydraulic and electrical installation space, time and costs.	ALL
4707 EV - 1 PUMP 2P HH (FIX SPEED)	Evaporator hydronic module, compatible with constant flow control. The unit is provided with 1 fixed speed pump, with 2-pole motor. Residual head of 200 kPa approximately. Specifications and characteristic curves are available in the dedicated bulletin section.	The hydronic module includes the pumps and the main water circuit components, thus optimizing hydraulic and electrical installation space, time and costs.	ALL
4711 EV - 2 PUMPS 2P LH (FIX SPEED)	Evaporator hydronic module, compatible with constant flow control. The unit is provided with 2 fixed speed pumps, with 2-pole motor. Residual head of 100 kPa approximately. The pumps are controlled in duty/standby, with running hours equalization and changeover on device failure. Specifications and characteristic curves are available in the dedicated bulletin section.	The hydronic module includes the pumps and the main water circuit components, thus optimizing hydraulic and electrical installation space, time and costs.	ALL
4712 EV - 2 PUMPS 2P HH (FIX SPEED)	Evaporator hydronic module, compatible with constant flow control. The unit is provided with 2 fixed speed pumps, with 2-pole motor. Residual head of 200 kPa approximately. The pumps are controlled in duty/standby, with running hours equalization and changeover on device failure. Specifications and characteristic curves are available in the dedicated bulletin section.	The hydronic module includes the pumps and the main water circuit components, thus optimizing hydraulic and electrical installation space, time and costs.	ALL
4713 EV - RELAY 1 PUMP + 0-10V SIG	Evaporator hydronic module, compatible with constant or variable flow control. The unit is provided with 1 relay and a 0-10V signal terminal to control the activation and the speed of 1 external variable speed pump.	The hydronic module controls the external pumps with the unit controller logic.	ALL
4714 EV - RELAY 2 PUMPS + 0-10V SIG	Evaporator hydronic module, compatible with constant or variable flow control. The unit is provided with 2 relays and a 0-10V signal terminal to control the activation and the speed of 2 external variable speed pump. The pumps are controlled in duty/standby, with running hours equalization and changeover on device failure.	The hydronic module controls the external pumps with the unit controller logic.	ALL
4717 EV - 1 PUMP 2P LH (VAR SPEED)	Evaporator hydronic module, compatible with constant or variable flow control. The unit is provided with 1 variable speed pump, with 2-pole motor. Residual head of 100 kPa approximately. Specifications and characteristic curves are available in the dedicated bulletin section.	The hydronic module includes the pumps and the main water circuit components, thus optimizing hydraulic and electrical installation space, time and costs.	ALL
4718 EV - 1 PUMP 2P HH (VAR SPEED)	Evaporator hydronic module, compatible with constant or variable flow control. The unit is provided with 1 variable speed pump, with 2-pole motor. Residual head of 200 kPa approximately. Specifications and characteristic curves are available in the dedicated bulletin section.	The hydronic module includes the pumps and the main water circuit components, thus optimizing hydraulic and electrical installation space, time and costs.	ALL

OPTIONS

OPTIONS	DESCRIPTIONS	BENEFITS	AVAILABLE FOR MODELS
4722 EV - 2 PUMPS 2P LH (VAR SPEED)	Evaporator hydronic module, compatible with constant or variable flow control. The unit is provided with 2 variable speed pumps, with 2-pole motor. Residual head of 100 kPa approximately. The pumps are controlled in duty/standby, with running hours equalization and changeover on device failure. Specifications and characteristic curves are available in the dedicated bulletin section.	The hydronic module includes the pumps and the main water circuit components, thus optimizing hydraulic and electrical installation space, time and costs.	ALL
4723 EV - 2 PUMPS 2P HH (VAR SPEED)	Evaporator hydronic module, compatible with constant or variable flow control. The unit is provided with 2 variable speed pumps, with 2-pole motor. Residual head of 200 kPa approximately. The pumps are controlled in duty/standby, with running hours equalization and changeover on device failure. Specifications and characteristic curves are available in the dedicated bulletin section.	The hydronic module includes the pumps and the main water circuit components, thus optimizing hydraulic and electrical installation space, time and costs.	ALL
4860 EV - PRIMARY FLOW CONTROL			
4861 EV - CONSTANT FLOW	Evaporator water flow control (plant primary circuit): constant flow. Compatible with hydronic modules without regulation devices (no pumps, no contacts), with ON/OFF regulation devices (relays) or with fixed speed pumps (codes: 4701, 4702, 4703, 4704, 4705, 4706, 4707, 4708, 4709, 4711, 4712 - hydronic modules availability depends on unit model).	The unit is set up to operate with a constant water flow in the heat exchanger (plant primary circuit). This is the only option available in case of unit without any water flow regulation devices (no pumps, no contacts), which means with water flow control provided by others. In case of unit with ON/OFF regulation devices or fixed speed pumps, the unit controller manages the pump activation to reduce pump consumption.	ALL
4862 EV - CONSTANT FLOW (PARAMETER)	Evaporator water flow control (plant primary circuit): constant flow (parameter set). Compatible with hydronic modules with modulating regulation devices (0-10V signal) or with variable speed pumps (codes: 4713, 4714, 4715, 4716, 4717, 4718, 4719, 4721, 4722, 4723 - hydronic modules availability depends on unit model).	The unit is set up to operate with a constant water flow in the heat exchanger (plant primary circuit). The unit controller manages the pump activation to reduce pump consumption. The pump speed is adjusted via 0-10V signal. The option provides the possibility to set the pump speed with a controller parameter. Once set, the speed pump remains constant until the next parameter adjustment. The parameter set constant flow control is useful during the unit installation and commissioning, to adjust water flow and pressure head according to the real plant characteristics.	ALL

OPTIONS

OPTIONS	DESCRIPTIONS	BENEFITS	AVAILABLE FOR MODELS
4864 EV – VPF (w/o DP)(SU, MM_PR)	<p>Evaporator water flow control (plant primary circuit): variable flow (delta P control). Only for single unit systems or unit with option 1541 (Multi Manager - Priority Master) if available.</p> <p>Compatible with hydronic modules with modulating regulation devices (0-10V signal) or with variable speed pumps (codes: 4713, 4714, 4715, 4716, 4717, 4718, 4719, 4721, 4722, 4723 - hydronic modules availability depends on unit model).</p> <p>The option includes: differential pressure transducer on the unit's heat exchanger and related controller expansion board, controller expansion board to read the plant side differential pressure transducer (4-20mA signal) and manage the hydraulic by-pass valve opening (0-10V signal).</p> <p>Compulsory equipment, supplied by others: plant side differential pressure transducer, plant side hydraulic by-pass valve.</p>	<p>The unit is set up to operate with a variable water flow in the heat exchanger (plant primary circuit).</p> <p>The unit controller manages the pump activation to reduce pump consumption. The pump speed is adjusted via 0-10V signal.</p> <p>The option provides a pump speed management based on the VPF (Variable Primary Flow) function. It keeps the delta P constant on the plant side (primary circuit), thus bringing significant pump consumption reduction during part load operation.</p> <p>The VPF function is applicable in systems with only the primary circuit.</p> <p>Further information available in the dedicated bulletin section.</p>	ALL
4865 EV – VPF (w DP)(SU, MM_PR)	<p>Evaporator water flow control (plant primary circuit): variable flow (delta P control). Only for single unit systems or unit with option 1541 (Multi Manager - Priority Master) if available.</p> <p>Compatible with hydronic modules with modulating regulation devices (0-10V signal) or with variable speed pumps (codes: 4713, 4714, 4715, 4716, 4717, 4718, 4719, 4721, 4722, 4723 - hydronic modules availability depends on unit model).</p> <p>The option includes: differential pressure transducer on the unit's heat exchanger and related controller expansion board, plant side differential pressure transducer (installation by others), controller expansion board to read the plant side differential pressure transducer (4-20mA signal) and manage the hydraulic by-pass valve opening (0-10V signal).</p> <p>Compulsory equipment, supplied by others: plant side hydraulic by-pass valve.</p>	<p>The unit is set up to operate with a variable water flow in the heat exchanger (plant primary circuit).</p> <p>The unit controller manages the pump activation to reduce pump consumption. The pump speed is adjusted via 0-10V signal.</p> <p>The option provides a pump speed management based on the VPF (Variable Primary Flow) function. It keeps the delta P constant on the plant side (primary circuit), thus bringing significant pump consumption reduction during part load operation.</p> <p>The VPF function is applicable in systems with only the primary circuit.</p> <p>Further information available in the dedicated bulletin section.</p>	ALL
4866 EV – VPF (M3000, CPRO, MM_N-PR)	<p>Evaporator water flow control (plant primary circuit): variable flow (delta P control). Only for multi-unit systems with external controller (Manager3000 or ClimaPRO) or unit with option 1542 (Multi Manager - Non Priority Master) if available.</p> <p>Compatible with hydronic modules with modulating regulation devices (0-10V signal) or with variable speed pumps (codes: 4713, 4714, 4715, 4716, 4717, 4718, 4719, 4721, 4722, 4723 - hydronic modules availability depends on unit model).</p> <p>The option includes: differential pressure transducer on the unit's heat exchanger and related controller expansion board.</p> <p>It shall be the customer responsibility to configure the multi-unit control system (Manager3000, ClimaPRO or Multi Manager Priority Master) with option VPF.</p>	<p>The unit is set up to operate with a variable water flow in the heat exchanger (plant primary circuit).</p> <p>The unit controller manages the pump activation to reduce pump consumption. The pump speed is adjusted via 0-10V signal.</p> <p>The option provides a pump speed management based on the VPF (Variable Primary Flow) function. It keeps the delta P constant on the plant side (primary circuit), thus bringing significant pump consumption reduction during part load operation.</p> <p>The VPF function is applicable in systems with only the primary circuit.</p> <p>Further information available in the dedicated bulletin section.</p>	ALL

OPTIONS

OPTIONS	DESCRIPTIONS	BENEFITS	AVAILABLE FOR MODELS
4867 EV - VPF.D (SU, MM_PR)	Evaporator water flow control (plant primary circuit): variable flow (delta T control). Only for single unit systems or unit with option 1541 (Multi Manager - Priority Master) if available. Compatible with hydronic modules with modulating regulation devices (0-10V signal) or with variable speed pumps (codes: 4713, 4714, 4715, 4716, 4717, 4718, 4719, 4721, 4722, 4723 - hydronic modules availability depends on unit model). The option includes: 2 plant side NTC temperature sensors (installation by others).	The unit is set up to operate with a variable water flow in the heat exchanger (plant primary circuit). The unit controller manages the pump activation to reduce pump consumption. The pump speed is adjusted via 0-10V signal. The option provides a pump speed management based on the VPF.D (Variable Primary Flow with Decoupler) function. It keeps the delta T constant on the plant side (primary circuit), thus bringing significant pump consumption reduction during part load operation. The VPF.D function is applicable in systems with the primary and secondary circuits separated by a hydraulic decoupler. Further information available in the dedicated bulletin section.	ALL
4868 EV - VPF.D(M3000, CPRO, MM_N-PR)	Evaporator water flow control (plant primary circuit): variable flow (delta T control). Only for multi-unit systems with external controller (Manager3000 or ClimaPRO) or unit with option 1542 (Multi Manager - Non Priority Master) if available. Compatible with hydronic modules with modulating regulation devices (0-10V signal) or with variable speed pumps (codes: 4713, 4714, 4715, 4716, 4717, 4718, 4719, 4721, 4722, 4723 - hydronic modules availability depends on unit model). It shall be the customer responsibility to configure the multi-unit control system (Manager3000, ClimaPRO or Multi Manager - Priority Master) with option VPF.D.	The unit is set up to operate with a variable water flow in the heat exchanger (plant primary circuit). The unit controller manages the pump activation to reduce pump consumption. The pump speed is adjusted via 0-10V signal. The option provides a pump speed management based on the VPF.D (Variable Primary Flow with Decoupler) function. It keeps the delta T constant on the plant side (primary circuit), thus bringing significant pump consumption reduction during part load operation. The VPF.D function is applicable in systems with the primary and secondary circuits separated by a hydraulic decoupler. Further information available in the dedicated bulletin section.	ALL
4869 EV - VPF.E	Evaporator water flow control (plant primary circuit): variable flow (delta T control). Compatible with hydronic modules with modulating regulation devices (0-10V signal) or with variable speed pumps (codes: 4713, 4714, 4715, 4716, 4717, 4718, 4719, 4721, 4722, 4723 - hydronic modules availability depends on unit model).	The unit is set up to operate with a variable water flow in the heat exchanger (plant primary circuit). The unit controller manages the pump activation to reduce pump consumption. The pump speed is adjusted via 0-10V signal. The option provides a pump speed management based on the VPF.E function. It keeps the delta T constant on the plant side (primary circuit), thus bringing significant pump consumption reduction during part load operation. The VPF.E function is applicable in systems with only the primary circuit and with the hydraulic terminals equipped 3 way valve (by-pass). Further information available in the dedicated bulletin section.	ALL
4940 BUFFER TANK			
4941 EV - WITH BUFFER TANK	Buffer tank covered by a 20 mm thick of insulation lining in closed-cell reticulated foam, which capacity depends on the unit size (see the dedicated table). In the dedicated section are described all the factory-mounted components included in the buffer tank system.	It helps to reach the plant water content required for the correct unit operation (see dedicated section "Hydraulic Data").	ALL
2430 PIPING KIT ANTIFREEZE HEATER			
2431 ANTIFREEZE PIPING	Electrical heaters on pipes .This option is mandatory if the unit is supposed to work with outdoor temperature below 0°C	It protects the unit against ice formation on its hydraulic components.	ALL

OPTIONS

OPTIONS	DESCRIPTIONS	BENEFITS	AVAILABLE FOR MODELS
2432 ANTIFREEZE PIPING, PUMPS	Electrical heaters on pipes and other hydraulic unit's components. This option is mandatory if the unit is supposed to work with outdoor temperature below 0°C. Only for units provided with on-board pumps.	It protects the unit against ice formation on its hydraulic components.	ALL
2433 ANTIFREEZE PIPING, PUMPS, TANK	Electrical heaters on pipes and other hydraulic unit's components. This option is mandatory if the unit is supposed to work with outdoor temperature below 0°C. Only for units provided with on-board pumps.		ALL
2910 HYDRAULIC CONNECTIONS			
2911 FLANGED HYDRAULIC CONNECTIONS	Grooved coupling with flanged counter-pipe user/source side.		ALL
2020 ANTI-INTRUSION GRILLS			
2021 ANTI-INTRUSION GRILLS	Anti-intrusions grills	Avoid the intrusion of solid bodies into the unit's structure.	ALL
2590 SOUNDPROOFING INSULATION			
2591 COMPRESSOR SOUNDPROOFING INSULATION	Compressor enclosure with soundproofing insulation in polyester fiber mat	Noise emission reduction	ALL
9970 PACKING			
9969 NYLON + WOODEN CRATE PACKING	Unit provided with wooden cage and covered with nylon		ALL
9971 WITHOUT PACKAGING	Unit provided with plastic supports		ALL
9974 MARINE PACKING	Unit provided with barrier bag and wooden cage		ALL
9979 CONTAINER PACKING	Unit provided with container slides and covered with nylon		ALL
9996 CONTAINER SLIDES	Unit provided with container slides		ALL
9999 SUPPORTS AND NYLON	Unit provided with plastic supports and covered with nylon		ALL
9920 BRACKETS FOR LATERAL LIFTING			
9921 BRACKETS FOR LATERAL LIFTING	Metal brackets to forklift the unit	This option allows easy lifting and handling of the unit.	ALL
AC01 ACCESSOR. SUPPLIED SEPARATELY			
AC01 EVAPORATOR WATER FLOWSWITCH	Flow switch with stainless scoop AISI 316L and IP65 protection suitable for installation in industrial plant pipes. It should be installed in a straight pipe without filters, valves, etc., long at least 5 times its diameter, both upstream and downstream.	Signaling of lack of or excessive reduction of flow, it generates an alarm that is in automatic or manual reset depending on n ° alarms per hour and the maximum time of operation of the pump under conditions of low flow rate.	ALL
AC03 LIFTING BARS			ALL
AC04 RUBBER TYPE ANTIVIBR.MOUNTING			ALL

OPTIONS

Additional information - IMPORTANT -

1015 - Heat exchangers NSW certified

The certification is available for the evaporator only. If the certification is required also for the recovery heat exchanger (versions /D), please contact our sales department.

3301 - Compressor power factor correction

1511 - Unit with soft start

There is a mutual exclusion rule between the compressor rephrasing capacitors and the soft-start device. When both accessories are required together, a feasibility analysis is needed. If the configuration is available as a special execution, an extra-price may be quoted.

2591 – Compressor soundproofing insulation

Compressor compartment soundproofing insulation

characteristics: polyester fiber mat (thickness of 30 mm).

Pump/s soundproofing insulation characteristics: 30 mm thick

Fiberform (polyester fibers).

Sound power reduction: -1 dB(A).

This option is not compatible with opt. 2282 – NR kit.

1431 - Night mode

With factory settings, the noise reduction achieved is: -3 dB(A)

818 – Oversized EC fans

This option allows to provide an available static pressure at the air discharge of the fans. Units with this option are suitable to win maximum air pressure drop of 150 Pa. From 100 Pa to 150 Pa there is a reduction of the maximum outdoor air ambient temperature. The maximum reduction at 150 Pa is 3°C.

This option is not compatible with opt. 2282 – NR kit.

1541 – Multi Manager – Priority Master

1542 – Multi Manager – Non-Priority Master

These options are not compatible with options:

5922 - ClimaPRO ModBUS RS485 – MID

5923 - ClimaPRO BacNET over IP

4864 – EV-VPF (w/o DP)(SU, MM PR) (VPF option for plants with a Single Unit or for Priority Master units – plant side differential pressure transducer non included)

4865 – EV-VPF (w DP)(SU, MM PR) (VPF option for plants with a Single Unit or for Priority Master units – plant side differential pressure transducer excluded)

4866 – EV-VPF (M3000, CPRO, MM N-PR) (VPF option for plants with Manager3000, ClimaPro, and for Non-Priority Master units)

4867 – EV-VPF.D (SU, MM PR) (VPF.D option for plants with a Single Unit or for Priority Master units)

4868 – EV-VPF.D(M3000, CPRO, MM N-PR) (VPF.D option for plants with Manager3000, ClimaPro, and for Non-Priority Master units)

4868 – EV-VPF.D(M3000, CPRO, MM N-PR) (VPF.D option for plants with Manager3000, ClimaPro, and for Non-Priority Master units)

OPTIONS

Chiller Plant Control with Active Optimization System

ClimaPRO System Manager

ClimaPRO System Manager represents the state-of-the-art platform for chiller plant management and control.

ClimaPRO ensures to actively optimize the entire chiller plant by managing and adjusting each component directly involved in the production and the distribution of the heating and the cooling energies, therefore involving chillers and heat pumps, pumping groups as well as the source-side devices like, for example, the cooling towers.

In particular, ClimaPRO measures in real-time all the operating variables from the for each individual device and each of the main system branche, by using serial communication lines as well as dedicated analogue signals.

The acquired data are then compared with the design data of each single unit at any working conditions, thus allowing to implement control strategies based on dynamic algorithms which take into account the real operating conditions.

On the basis of these values, an advanced diagnostic module also allows to assess the level of for each individual unit, translating data into easy-to-read information in order to simplify and optimize the maintenance activities.

The "Chart Builder" software module allows to display the trends of the main operating variables. The "Reporting" module allows to send reports to selected users, including data and system's status of the main devices as well as to perform calculation of the energy indexes for each single unit and for the entire chiller plant.

The accessibility to ClimaPRO System Manager is ensured by an integrated web server that makes it visible from any computer equipped with a web browser, either locally or remotely.



5.1 GENERAL TECHNICAL DATA

NX2-G06

[SI System]

NX2-G06		0042	0052	0062	0072	0082	0092	0102	0112	0122	0142	
Power supply		V/ph/Hz 400/3+N/50 400/3+N/50 400/3+N/50 400/3+N/50 400/3+N/50 400/3+N/50 400/3/50 400/3/50 400/3/50 400/3/50										
PERFORMANCE												
COOLING ONLY (GROSS VALUE)												
Cooling capacity	(1)	kW	40,53	48,58	54,16	60,98	68,18	79,82	93,31	103,8	116,5	129,6
Total power input	(1)	kW	13,64	16,10	17,02	17,66	20,47	25,36	27,94	32,74	38,27	44,42
EER	(1)	kW/kW	2,978	3,019	3,188	3,446	3,327	3,142	3,344	3,174	3,042	2,919
ESEER	(1)	kW/kW										
COOLING ONLY (EN14511 VALUE)												
Cooling capacity	(2)(3)	kW	40,40	48,50	54,00	60,80	68,00	79,60	93,10	103,5	116,2	129,3
EER	(2)(3)	kW/kW	2,920	2,970	3,120	3,380	3,260	3,090	3,290	3,110	2,990	2,870
ESEER	(2)(3)	kW/kW	-	-	-	-	-	-	-	-	-	-
COOLING WITH PARTIAL RECOVERY												
Cooling capacity	(4)	kW	42,05	50,40	56,20	63,27	70,74	82,81	96,81	107,7	120,9	134,5
Total power input	(4)	kW	13,21	15,58	16,47	17,10	19,82	24,54	27,05	31,68	37,02	42,95
Desuperheater heating capacity	(4)	kW	11,11	13,30	14,12	14,16	16,66	21,03	22,80	27,08	32,02	37,50
EXCHANGERS												
HEAT EXCHANGER USER SIDE IN COOLING												
Water flow	(1)	l/s	1,938	2,323	2,590	2,916	3,261	3,817	4,462	4,965	5,573	6,198
Pressure drop at the heat exchanger	(2)	kPa	44,8	33,3	41,4	45,4	46,2	45,3	36,6	45,4	45,5	42,6
PARTIAL RECOVERY USER SIDE IN REFRIGERATION												
Water flow	(4)	l/s	0,536	0,642	0,682	0,683	0,804	1,015	1,101	1,307	1,546	1,810
Pressure drop at the heat exchanger	(4)	kPa	6,58	9,44	10,6	10,7	14,8	11,6	13,7	19,3	19,0	26,0
REFRIGERANT CIRCUIT												
Compressors nr.		N°	2	2	2	2	2	2	2	2	2	2
Number of capacity steps		N°	2	2	2	2	2	2	2	2	2	2
No. Circuits		N°	1	1	1	1	1	1	1	1	1	1
Regulation			STEPS	STEPS	STEPS	STEPS	STEPS	STEPS	STEPS	STEPS	STEPS	STEPS
Min. capacity step		%	50	50	50	50	50	50	50	50	50	50
Refrigerant			R454B	R454B	R454B	R454B	R454B	R454B	R454B	R454B	R454B	R454B
Refrigerant charge		kg	7,60	7,60	8,00	9,90	10,0	11,1	13,1	14,3	15,5	15,8
Oil charge		kg	6,00	6,60	5,40	5,40	5,40	5,40	8,00	10,6	10,6	10,6
Rc (ASHRAE)	(5)	kg/kW	0,19	0,16	0,15	0,16	0,15	0,14	0,14	0,14	0,13	0,12
FANS												
Quantity		N°	4	4	4	6	6	6	2	2	2	2
Air flow		m³/s	3,75	3,75	3,75	5,66	5,66	5,66	8,49	8,49	8,49	8,49
Fans power input		kW	0,30	0,30	0,30	0,30	0,30	0,30	1,20	1,20	1,20	1,20
NOISE LEVEL												
Sound Pressure	(6)	dB(A)	49	50	49	51	52	52	52	52	52	53
Sound power level in cooling	(7)(8)	dB(A)	81	82	81	83	84	84	84	84	84	85
SIZE AND WEIGHT												
A	(9)	mm	1825	1825	1825	2395	2395	2395	2825	2825	2825	2825
B	(9)	mm	1195	1195	1195	1195	1195	1195	1195	1195	1195	1195
H	(9)	mm	1865	1865	1865	1865	1865	1865	1980	1980	1980	1980
Operating weight	(9)	kg	500	510	550	630	630	640	770	770	850	920

Notes:

- 1 Plant (side) cooling exchanger water (in/out) 12,00°C/7,00°C; Source (side) heat exchanger air (in) 35,0°C.
- 2 Plant (side) cooling exchanger water (in/out) 12,00°C/7,00°C; Source (side) heat exchanger air (in) 35,0°C.
- 3 Values in compliance with EN14511
- 4 Plant (side) cooling exchanger water (in/out) 12,00°C/7,00°C; Source (side) heat exchanger air (in) 35,0°C; Plant (side) heat exchanger recovery water (in/out) 40,00°C/45,00°C.
- 5 Rated in accordance with AHRI Standard 550/590
- 6 Average sound pressure level at 10m distance, unit in a free field on a reflective surface; non-binding value calculated from the sound power level.
- 7 Sound power on the basis of measurements taken in compliance with ISO 9614.
- 8 Sound power level in cooling, outdoors.
- 9 Unit in standard configuration, without optional accessories.

- Not available

Data certified in EUROVENT

GENERAL TECHNICAL DATA

NX2-G06

[SI System]

NX2-G06		0162	0182	0202	0222	
Power supply		V/ph/Hz 400/3/50 400/3/50 400/3/50 400/3/50				
PERFORMANCE						
COOLING ONLY (GROSS VALUE)						
Cooling capacity	(1)	kW	152,0	174,2	186,9	208,7
Total power input	(1)	kW	47,39	55,37	61,54	70,86
EER	(1)	kW/kW	3,207	3,144	3,039	2,944
ESEER	(1)	kW/kW				
COOLING ONLY (EN14511 VALUE)						
Cooling capacity	(2)(3)	kW	151,7	173,9	186,6	208,3
EER	(2)(3)	kW/kW	3,150	3,100	3,000	2,900
ESEER	(2)(3)	kW/kW	-	-	-	-
COOLING WITH PARTIAL RECOVERY						
Cooling capacity	(4)	kW	157,7	180,7	193,9	216,5
Total power input	(4)	kW	45,85	53,56	59,51	68,51
Desuperheater heating capacity	(4)	kW	39,08	46,21	51,72	60,04
EXCHANGERS						
HEAT EXCHANGER USER SIDE IN COOLING						
Water flow	(1)	l/s	7,268	8,331	8,937	9,979
Pressure drop at the heat exchanger	(2)	kPa	47,9	44,1	38,5	48,0
PARTIAL RECOVERY USER SIDE IN REFRIGERATION						
Water flow	(4)	l/s	1,887	2,231	2,496	2,898
Pressure drop at the heat exchanger	(4)	kPa	19,0	26,6	22,4	30,2
REFRIGERANT CIRCUIT						
Compressors nr.		N°	2	2	2	2
Number of capacity steps		N°	2	2	2	2
No. Circuits		N°	1	1	1	1
Regulation			STEPS	STEPS	STEPS	STEPS
Min. capacity step		%	50	50	50	50
Refrigerant			R454B	R454B	R454B	R454B
Refrigerant charge		kg	21,9	22,7	22,8	22,9
Oil charge		kg	10,6	10,6	10,6	10,6
Rc (ASHRAE)	(5)	kg/kW	0,15	0,13	0,12	0,11
FANS						
Quantity		N°	3	3	3	3
Air flow		m³/s	12,83	12,83	12,83	12,83
Fans power input		kW	1,20	1,20	1,20	1,20
NOISE LEVEL						
Sound Pressure	(6)	dB(A)	54	55	55	56
Sound power level in cooling	(7)(8)	dB(A)	86	87	87	88
SIZE AND WEIGHT						
A	(9)	mm	3980	3980	3980	3980
B	(9)	mm	1195	1195	1195	1195
H	(9)	mm	1980	1980	1980	1980
Operating weight	(9)	kg	1130	1170	1180	1220

Notes:

- 1 Plant (side) cooling exchanger water (in/out) 12,00°C/7,00°C; Source (side) heat exchanger air (in) 35,0°C.
- 2 Plant (side) cooling exchanger water (in/out) 12,00°C/7,00°C; Source (side) heat exchanger air (in) 35,0°C.
- 3 Values in compliance with EN14511
- 4 Plant (side) cooling exchanger water (in/out) 12,00°C/7,00°C; Source (side) heat exchanger air (in) 35,0°C; Plant (side) heat exchanger recovery water (in/out) 40,00°C/45,00°C.
- 5 Rated in accordance with AHRI Standard 550/590
- 6 Average sound pressure level at 10m distance, unit in a free field on a reflective surface; non-binding value calculated from the sound power level.
- 7 Sound power on the basis of measurements taken in compliance with ISO 9614.
- 8 Sound power level in cooling, outdoors.
- 9 Unit in standard configuration, without optional accessories.

- Not available

Data certified in EUROVENT

GENERAL TECHNICAL DATA

NX2-G06 + UP kit

[SI System]

NX2-G06 + UP kit		0042	0052	0062	0072	0082	0092	0102	0112	0122	0142	
Power supply	V/ph/Hz	400/3+N/50	400/3+N/50	400/3+N/50	400/3+N/50	400/3+N/50	400/3+N/50	400/3/50	400/3/50	400/3/50	400/3/50	
PERFORMANCE												
COOLING ONLY (GROSS VALUE)												
Cooling capacity	(1)	kW	41,19	49,35	54,80	61,64	69,02	80,86	94,36	104,7	118,1	131,8
Total power input	(1)	kW	12,75	14,92	15,72	16,66	19,18	23,44	28,06	32,41	37,17	42,39
EER	(1)	kW/kW	3,244	3,309	3,490	3,689	3,594	3,457	3,359	3,231	3,175	3,108
ESEER	(1)	kW/kW										
COOLING ONLY (EN14511 VALUE)												
Cooling capacity	(2)(3)	kW	41,10	49,20	54,60	61,40	68,80	80,60	94,10	104,4	117,8	131,4
EER	(2)(3)	kW/kW	3,160	3,250	3,420	3,620	3,520	3,380	3,310	3,170	3,120	3,050
ESEER	(2)(3)	kW/kW	-	-	-	-	-	-	-	-	-	-
COOLING WITH PARTIAL RECOVERY												
Cooling capacity	(4)	kW	42,73	51,20	56,85	63,95	71,61	83,89	97,89	108,7	122,6	136,7
Total power input	(4)	kW	12,34	14,44	15,22	16,14	18,57	22,68	27,22	31,41	36,01	41,04
Desuperheater heating capacity	(4)	kW	10,31	12,25	12,96	13,26	15,52	19,31	21,48	25,36	29,61	34,27
EXCHANGERS												
HEAT EXCHANGER USER SIDE IN COOLING												
Water flow	(1)	l/s	1,970	2,360	2,621	2,948	3,301	3,867	4,512	5,009	5,650	6,301
Pressure drop at the heat exchanger	(2)	kPa	46,3	34,4	42,4	46,4	47,3	46,5	37,5	46,2	46,7	44,0
PARTIAL RECOVERY USER SIDE IN REFRIGERATION												
Water flow	(4)	l/s	0,498	0,591	0,626	0,640	0,749	0,932	1,037	1,224	1,429	1,654
Pressure drop at the heat exchanger	(4)	kPa	5,67	8,00	8,97	9,38	12,8	9,81	12,1	16,9	16,2	21,7
REFRIGERANT CIRCUIT												
Compressors nr.		N°	2	2	2	2	2	2	2	2	2	2
Number of capacity steps		N°	2	2	2	2	2	2	2	2	2	2
No. Circuits		N°	1	1	1	1	1	1	1	1	1	1
Regulation			STEPS	STEPS	STEPS	STEPS	STEPS	STEPS	STEPS	STEPS	STEPS	STEPS
Min. capacity step		%	50	50	50	50	50	50	50	50	50	50
Refrigerant			R454B	R454B	R454B	R454B	R454B	R454B	R454B	R454B	R454B	R454B
Refrigerant charge		kg	7,60	7,60	8,00	9,90	10,0	11,1	13,1	14,3	15,5	15,8
Oil charge		kg	6,00	6,60	5,40	5,40	5,40	5,40	8,00	10,6	10,6	10,6
Rc (ASHRAE)	(5)	kg/kW	0,19	0,16	0,15	0,16	0,15	0,14	0,14	0,14	0,13	0,12
FANS												
Quantity		N°	4	4	4	6	6	6	2	2	2	2
Air flow		m³/s	4,84	4,84	4,84	7,28	7,28	7,28	10,98	10,98	10,98	10,98
Fans power input		kW	0,30	0,30	0,30	0,30	0,30	0,30	2,00	2,00	2,00	2,00
NOISE LEVEL												
Sound Pressure	(6)	dB(A)	53	53	53	54	55	55	57	57	57	58
Sound power level in cooling	(7)(8)	dB(A)	85	85	85	86	87	87	89	89	89	90
SIZE AND WEIGHT												
A	(9)	mm	1825	1825	1825	2395	2395	2395	2825	2825	2825	2825
B	(9)	mm	1195	1195	1195	1195	1195	1195	1195	1195	1195	1195
H	(9)	mm	1865	1865	1865	1865	1865	1865	1980	1980	1980	1980
Operating weight	(9)	kg	500	510	550	630	630	640	770	770	850	920

Notes:

- 1 Plant (side) cooling exchanger water (in/out) 12,00°C/7,00°C; Source (side) heat exchanger air (in) 35,0°C.
- 2 Plant (side) cooling exchanger water (in/out) 12,00°C/7,00°C; Source (side) heat exchanger air (in) 35,0°C.
- 3 Values in compliance with EN14511
- 4 Plant (side) cooling exchanger water (in/out) 12,00°C/7,00°C; Source (side) heat exchanger air (in) 35,0°C; Plant (side) heat exchanger recovery water (in/out) 40,00°C/45,00°C.
- 5 Rated in accordance with AHRI Standard 550/590
- 6 Average sound pressure level at 10m distance, unit in a free field on a reflective surface; non-binding value calculated from the sound power level.
- 7 Sound power on the basis of measurements taken in compliance with ISO 9614.
- 8 Sound power level in cooling, outdoors.
- 9 Unit in standard configuration, without optional accessories.
- Not available

Data certified in EUROVENT

GENERAL TECHNICAL DATA

NX2-G06 + UP kit

[SI System]

NX2-G06 + UP kit		0162	0182	0202	0222	
Power supply		V/ph/Hz 400/3/50 400/3/50 400/3/50 400/3/50				
PERFORMANCE						
COOLING ONLY (GROSS VALUE)						
Cooling capacity	(1)	kW	154,0	176,4	189,8	211,8
Total power input	(1)	kW	46,81	53,86	59,15	67,23
EER	(1)	kW/kW	3,291	3,273	3,206	3,152
ESEER	(1)	kW/kW				
COOLING ONLY (EN14511 VALUE)						
Cooling capacity	(2)(3)	kW	153,6	176,1	189,5	211,4
EER	(2)(3)	kW/kW	3,230	3,220	3,160	3,100
ESEER	(2)(3)	kW/kW	-	-	-	-
COOLING WITH PARTIAL RECOVERY						
Cooling capacity	(4)	kW	159,7	183,1	196,9	219,7
Total power input	(4)	kW	45,38	52,19	57,29	65,09
Desuperheater heating capacity	(4)	kW	36,43	42,72	47,45	54,66
EXCHANGERS						
HEAT EXCHANGER USER SIDE IN COOLING						
Water flow	(1)	l/s	7,363	8,438	9,077	10,13
Pressure drop at the heat exchanger	(2)	kPa	49,2	45,2	39,7	49,4
PARTIAL RECOVERY USER SIDE IN REFRIGERATION						
Water flow	(4)	l/s	1,758	2,062	2,290	2,638
Pressure drop at the heat exchanger	(4)	kPa	16,5	22,7	18,8	25,0
REFRIGERANT CIRCUIT						
Compressors nr.		N°	2	2	2	2
Number of capacity steps		N°	2	2	2	2
No. Circuits		N°	1	1	1	1
Regulation			STEPS	STEPS	STEPS	STEPS
Min. capacity step		%	50	50	50	50
Refrigerant			R454B	R454B	R454B	R454B
Refrigerant charge		kg	21,9	22,7	22,8	22,9
Oil charge		kg	10,6	10,6	10,6	10,6
Rc (ASHRAE)	(5)	kg/kW	0,14	0,13	0,12	0,11
FANS						
Quantity		N°	3	3	3	3
Air flow		m³/s	16,54	16,54	16,54	16,54
Fans power input		kW	2,00	2,00	2,00	2,00
NOISE LEVEL						
Sound Pressure	(6)	dB(A)	59	59	59	60
Sound power level in cooling	(7)(8)	dB(A)	91	91	91	92
SIZE AND WEIGHT						
A	(9)	mm	3980	3980	3980	3980
B	(9)	mm	1195	1195	1195	1195
H	(9)	mm	1980	1980	1980	1980
Operating weight	(9)	kg	1130	1170	1180	1220

Notes:

- 1 Plant (side) cooling exchanger water (in/out) 12,00°C/7,00°C; Source (side) heat exchanger air (in) 35,0°C.
- 2 Plant (side) cooling exchanger water (in/out) 12,00°C/7,00°C; Source (side) heat exchanger air (in) 35,0°C.
- 3 Values in compliance with EN14511
- 4 Plant (side) cooling exchanger water (in/out) 12,00°C/7,00°C; Source (side) heat exchanger air (in) 35,0°C; Plant (side) heat exchanger recovery water (in/out) 40,00°C/45,00°C.
- 5 Rated in accordance with AHRI Standard 550/590
- 6 Average sound pressure level at 10m distance, unit in a free field on a reflective surface; non-binding value calculated from the sound power level.
- 7 Sound power on the basis of measurements taken in compliance with ISO 9614.
- 8 Sound power level in cooling, outdoors.
- 9 Unit in standard configuration, without optional accessories.

- Not available

Data certified in EUROVENT

GENERAL TECHNICAL DATA

NX2-G06 + NR kit

[SI System]

NX2-G06 + NR kit		0042	0052	0062	0072	0082	0092	0102	0112	0122	0142	
Power supply		V/ph/Hz 400/3+N/50 400/3+N/50 400/3+N/50 400/3+N/50 400/3+N/50 400/3+N/50 400/3/50 400/3/50 400/3/50 400/3/50										
PERFORMANCE												
COOLING ONLY (GROSS VALUE)												
Cooling capacity	(1)	kW	40,06	47,85	53,66	60,58	67,63	78,81	92,45	102,8	115,2	127,7
Total power input	(1)	kW	13,55	16,11	17,09	17,38	20,28	25,38	28,33	33,31	39,14	45,66
EER	(1)	kW/kW	2,949	2,969	3,140	3,483	3,330	3,102	3,265	3,087	2,946	2,794
ESEER	(1)	kW/kW										
COOLING ONLY (EN14511 VALUE)												
Cooling capacity	(2)(3)	kW	39,90	47,70	53,50	60,40	67,40	78,60	92,20	102,5	114,9	127,4
EER	(2)(3)	kW/kW	2,900	2,930	3,090	3,410	3,270	3,050	3,210	3,030	2,890	2,760
ESEER	(2)(3)	kW/kW	-	-	-	-	-	-	-	-	-	-
COOLING WITH PARTIAL RECOVERY												
Cooling capacity	(4)	kW	41,56	49,64	55,67	62,85	70,17	81,77	95,91	106,7	119,5	132,5
Total power input	(4)	kW	13,11	15,57	16,52	16,82	19,62	24,54	27,41	32,22	37,85	44,14
Desuperheater heating capacity	(4)	kW	11,38	13,66	14,54	14,44	17,04	21,59	23,32	27,77	32,98	38,79
EXCHANGERS												
HEAT EXCHANGER USER SIDE IN COOLING												
Water flow	(1)	l/s	1,916	2,288	2,566	2,897	3,234	3,769	4,421	4,918	5,508	6,109
Pressure drop at the heat exchanger	(2)	kPa	43,8	32,3	40,6	44,8	45,4	44,2	36,0	44,5	44,4	41,4
PARTIAL RECOVERY USER SIDE IN REFRIGERATION												
Water flow	(4)	l/s	0,550	0,660	0,702	0,697	0,822	1,042	1,126	1,340	1,592	1,873
Pressure drop at the heat exchanger	(4)	kPa	6,92	9,96	11,3	11,1	15,5	12,3	14,3	20,3	20,1	27,9
REFRIGERANT CIRCUIT												
Compressors nr.		N°	2	2	2	2	2	2	2	2	2	2
Number of capacity steps		N°	2	2	2	2	2	2	2	2	2	2
No. Circuits		N°	1	1	1	1	1	1	1	1	1	1
Regulation			STEPS	STEPS	STEPS	STEPS	STEPS	STEPS	STEPS	STEPS	STEPS	STEPS
Min. capacity step		%	50	50	50	50	50	50	50	50	50	50
Refrigerant			R454B	R454B	R454B	R454B	R454B	R454B	R454B	R454B	R454B	R454B
Refrigerant charge		kg	7,60	7,60	8,00	9,90	10,0	11,1	13,1	14,3	15,5	15,8
Oil charge		kg	6,00	6,60	5,40	5,40	5,40	5,40	8,00	10,6	10,6	10,6
Rc (ASHRAE)	(5)	kg/kW	0,19	0,16	0,15	0,16	0,15	0,14	0,14	0,14	0,14	0,12
FANS												
Quantity		N°	4	4	4	6	6	6	2	2	2	2
Air flow		m³/s	3,51	3,51	3,51	5,34	5,34	5,34	7,89	7,89	7,89	7,89
Fans power input		kW	0,20	0,20	0,20	0,20	0,20	0,20	1,10	1,10	1,10	1,10
NOISE LEVEL												
Sound Pressure	(6)	dB(A)	45	46	45	47	48	48	48	48	48	50
Sound power level in cooling	(7)(8)	dB(A)	77	78	77	79	80	80	80	80	80	82
SIZE AND WEIGHT												
A	(9)	mm	1825	1825	1825	2395	2395	2395	2825	2825	2825	2825
B	(9)	mm	1195	1195	1195	1195	1195	1195	1195	1195	1195	1195
H	(9)	mm	1865	1865	1865	1865	1865	1865	1980	1980	1980	1980
Operating weight	(9)	kg	500	510	550	630	630	640	770	770	850	920

Notes:

- 1 Plant (side) cooling exchanger water (in/out) 12,00°C/7,00°C; Source (side) heat exchanger air (in) 35,0°C.
- 2 Plant (side) cooling exchanger water (in/out) 12,00°C/7,00°C; Source (side) heat exchanger air (in) 35,0°C.
- 3 Values in compliance with EN14511
- 4 Plant (side) cooling exchanger water (in/out) 12,00°C/7,00°C; Source (side) heat exchanger air (in) 35,0°C; Plant (side) heat exchanger recovery water (in/out) 40,00°C/45,00°C.
- 5 Rated in accordance with AHRI Standard 550/590
- 6 Average sound pressure level at 10m distance, unit in a free field on a reflective surface; non-binding value calculated from the sound power level.
- 7 Sound power on the basis of measurements taken in compliance with ISO 9614.
- 8 Sound power level in cooling, outdoors.
- 9 Unit in standard configuration, without optional accessories.

- Not available

Data certified in EUROVENT

GENERAL TECHNICAL DATA

NX2-G06 + NR kit

[SI System]

NX2-G06 + NR kit		0162	0182	0202	0222	
Power supply		V/ph/Hz 400/3/50 400/3/50 400/3/50 400/3/50				
PERFORMANCE						
COOLING ONLY (GROSS VALUE)						
Cooling capacity	(1)	kW	150,4	171,9	184,2	206,4
Total power input	(1)	kW	48,39	56,79	63,35	73,22
EER	(1)	kW/kW	3,107	3,026	2,905	2,820
ESEER	(1)	kW/kW				
COOLING ONLY (EN14511 VALUE)						
Cooling capacity	(2)(3)	kW	150,1	171,6	183,9	206,1
EER	(2)(3)	kW/kW	3,050	2,980	2,870	2,780
ESEER	(2)(3)	kW/kW	-	-	-	-
COOLING WITH PARTIAL RECOVERY						
Cooling capacity	(4)	kW	156,0	178,4	191,1	214,2
Total power input	(4)	kW	46,82	54,92	61,25	70,77
Desuperheater heating capacity	(4)	kW	40,25	47,75	53,60	62,41
EXCHANGERS						
HEAT EXCHANGER USER SIDE IN COOLING						
Water flow	(1)	l/s	7,191	8,223	8,809	9,871
Pressure drop at the heat exchanger	(2)	kPa	46,9	42,9	37,4	47,0
PARTIAL RECOVERY USER SIDE IN REFRIGERATION						
Water flow	(4)	l/s	1,943	2,305	2,587	3,013
Pressure drop at the heat exchanger	(4)	kPa	20,2	28,4	24,0	32,6
REFRIGERANT CIRCUIT						
Compressors nr.		N°	2	2	2	2
Number of capacity steps		N°	2	2	2	2
No. Circuits		N°	1	1	1	1
Regulation			STEPS	STEPS	STEPS	STEPS
Min. capacity step		%	50	50	50	50
Refrigerant			R454B	R454B	R454B	R454B
Refrigerant charge		kg	21,9	22,7	22,8	22,9
Oil charge		kg	10,6	10,6	10,6	10,6
Rc (ASHRAE)	(5)	kg/kW	0,15	0,13	0,12	0,11
FANS						
Quantity		N°	3	3	3	3
Air flow		m³/s	11,83	11,83	11,83	11,83
Fans power input		kW	1,10	1,10	1,10	1,10
NOISE LEVEL						
Sound Pressure	(6)	dB(A)	50	51	51	52
Sound power level in cooling	(7)(8)	dB(A)	82	83	83	84
SIZE AND WEIGHT						
A	(9)	mm	3980	3980	3980	3980
B	(9)	mm	1195	1195	1195	1195
H	(9)	mm	1980	1980	1980	1980
Operating weight	(9)	kg	1130	1170	1180	1220

Notes:

- 1 Plant (side) cooling exchanger water (in/out) 12,00°C/7,00°C; Source (side) heat exchanger air (in) 35,0°C.
- 2 Plant (side) cooling exchanger water (in/out) 12,00°C/7,00°C; Source (side) heat exchanger air (in) 35,0°C.
- 3 Values in compliance with EN14511
- 4 Plant (side) cooling exchanger water (in/out) 12,00°C/7,00°C; Source (side) heat exchanger air (in) 35,0°C; Plant (side) heat exchanger recovery water (in/out) 40,00°C/45,00°C.
- 5 Rated in accordance with AHRI Standard 550/590
- 6 Average sound pressure level at 10m distance, unit in a free field on a reflective surface; non-binding value calculated from the sound power level.
- 7 Sound power on the basis of measurements taken in compliance with ISO 9614.
- 8 Sound power level in cooling, outdoors.
- 9 Unit in standard configuration, without optional accessories.

- Not available

Data certified in EUROVENT

6.1 TECHNICAL DATA SEASONAL EFFICIENCY IN COOLING (EN14825 VALUE)

[SI System]

ENERGY EFFICIENCY

SEASONAL EFFICIENCY IN COOLING (Reg. EU 2016/2281)

Ambient refrigeration

NX2-G06			0042	0052	0062	0072	0082	0092	0102	0112	0122	0142
Prated,c	(1)	kW	40,4	48,5	54,0	60,8	68,0	79,6	93,1	103,5	116,2	129,3
SEER	(1) (2)	-	4,61	4,72	4,56	4,65	4,57	4,60	4,53	4,29	4,32	4,38
Performance ηs	(1) (3)	%	181,0	186,0	179,0	183,0	180,0	181,0	178,0	168,0	170,0	172,0
NX2-G06			0162	0182	0202	0222						
Prated,c	(1)	kW	151,7	173,9	186,6	208,3						
SEER	(1) (2)	-	4,48	4,49	4,48	4,46						
Performance ηs	(1) (3)	%	176,0	177,0	176,0	175,0						

NX2-G06 + UP kit			0042	0052	0062	0072	0082	0092	0102	0112	0122	0142
Prated,c	(1)	kW	41,1	49,2	54,6	61,4	68,8	80,6	94,1	104,4	117,8	131,4
SEER	(1) (2)	-	4,70	4,83	4,65	4,72	4,65	4,69	4,54	4,31	4,37	4,44
Performance ηs	(1) (3)	%	185,0	190,0	183,0	186,0	183,0	185,0	179,0	169,0	172,0	175,0
NX2-G06 + UP kit			0162	0182	0202	0222						
Prated,c	(1)	kW	153,6	176,1	189,5	211,4						
SEER	(1) (2)	-	4,51	4,54	4,53	4,52						
Performance ηs	(1) (3)	%	177,0	179,0	178,0	178,0						

NX2-G06 + NR kit			0042	0052	0062	0072	0082	0092	0102	0112	0122	0142
Prated,c	(1)	kW	39,9	47,7	53,5	60,4	67,4	78,6	92,2	102,5	114,9	127,4
SEER	(1) (2)	-	4,60	4,71	4,54	4,66	4,57	4,59	4,54	4,27	4,29	4,34
Performance ηs	(1) (3)	%	181,0	185,0	179,0	184,0	180,0	180,0	179,0	168,0	169,0	171,0
NX2-G06 + NR kit			0162	0182	0202	0222						
Prated,c	(1)	kW	150,1	171,6	183,9	206,1						
SEER	(1) (2)	-	4,48	4,47	4,45	4,40						
Performance ηs	(1) (3)	%	176,0	176,0	175,0	173,0						

Notes:

(1) Parameter calculated according to [REGULATION (EU) N. 2016/2281]

(2) Seasonal energy efficiency ratio

(3) Seasonal space cooling energy efficiency

The units highlighted in this publication contain R454B [GWP₁₀₀ 466] fluorinated greenhouse gases.

Data certified in EUROVENT

7.1 OPERATING LIMITS

All versions Sizes 0042 - 0092

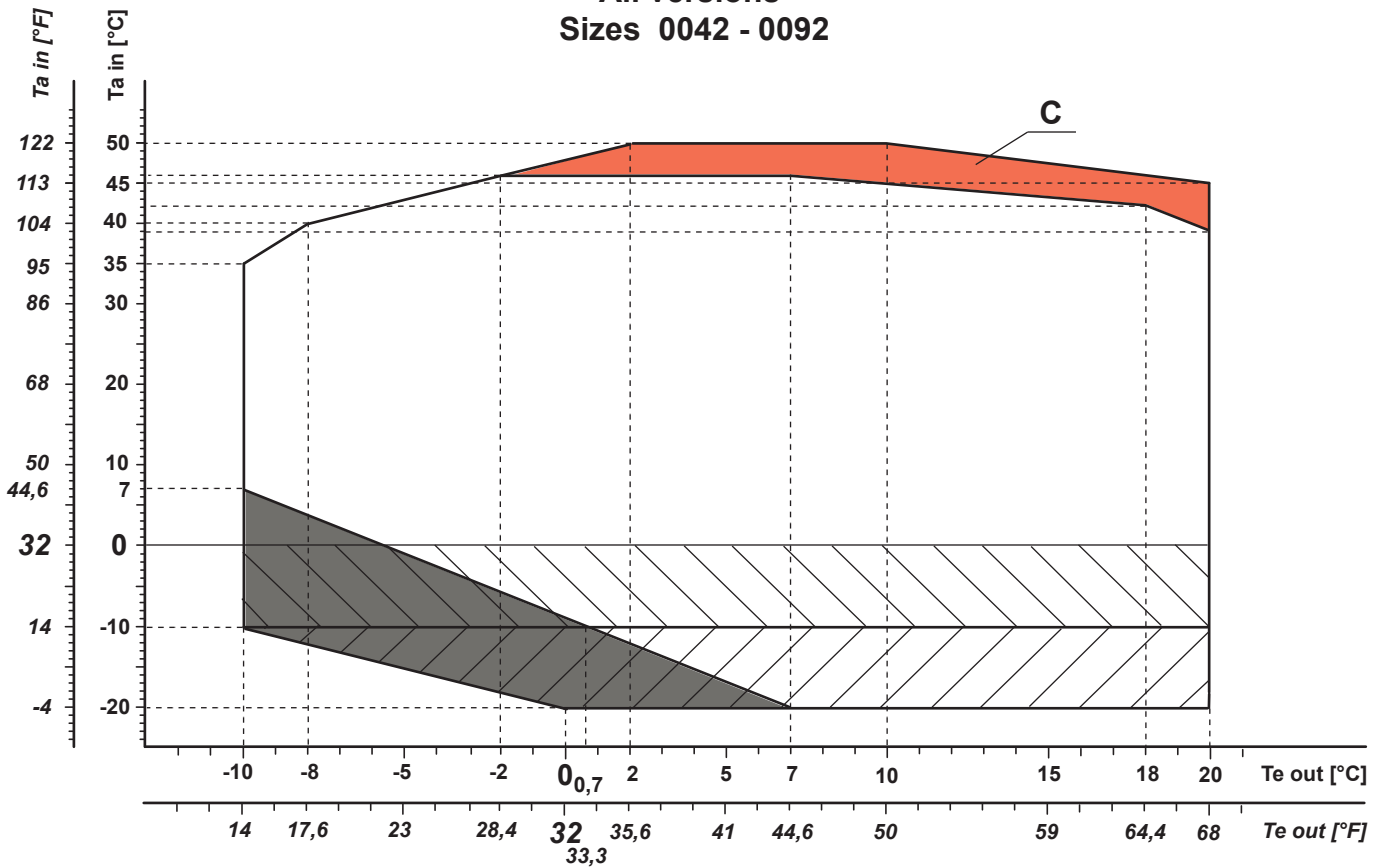

$T_{a\ in}$ Outdoor air temperature [°C]
 $T_{e\ out}$ Evaporator outlet temperature [°C]

 - Version STD

 - DVV2F (code 821) or EC fans (code 808)

 - Part load operation

 - Antifreeze heaters on pipes, pumps* and buffer tank* (code 2432 o 2433).
 (* if present)

- Operation between -10°C and -20°C of outdoor air temperature is allowed for wind protected installations (wind speed lower than 2 m/s - 6,56 ft/s)

 - Extra insulation on heat exchangers, pipes, pumps* and buffer tank* (RFQ),
 - Extra antifreeze heaters on heat exchangers, pipes, pumps* and buffer tank* (RFQ),
 (* if present)

NOTES:

For the temperature limits of each size please refer to the selection software ElcaWorld (the diagram over 40°C could vary according to the size and the version of the selected unit).

RFQ: Request for quotation

OPERATING LIMITS

**All versions
Sizes 0102 - 0222**

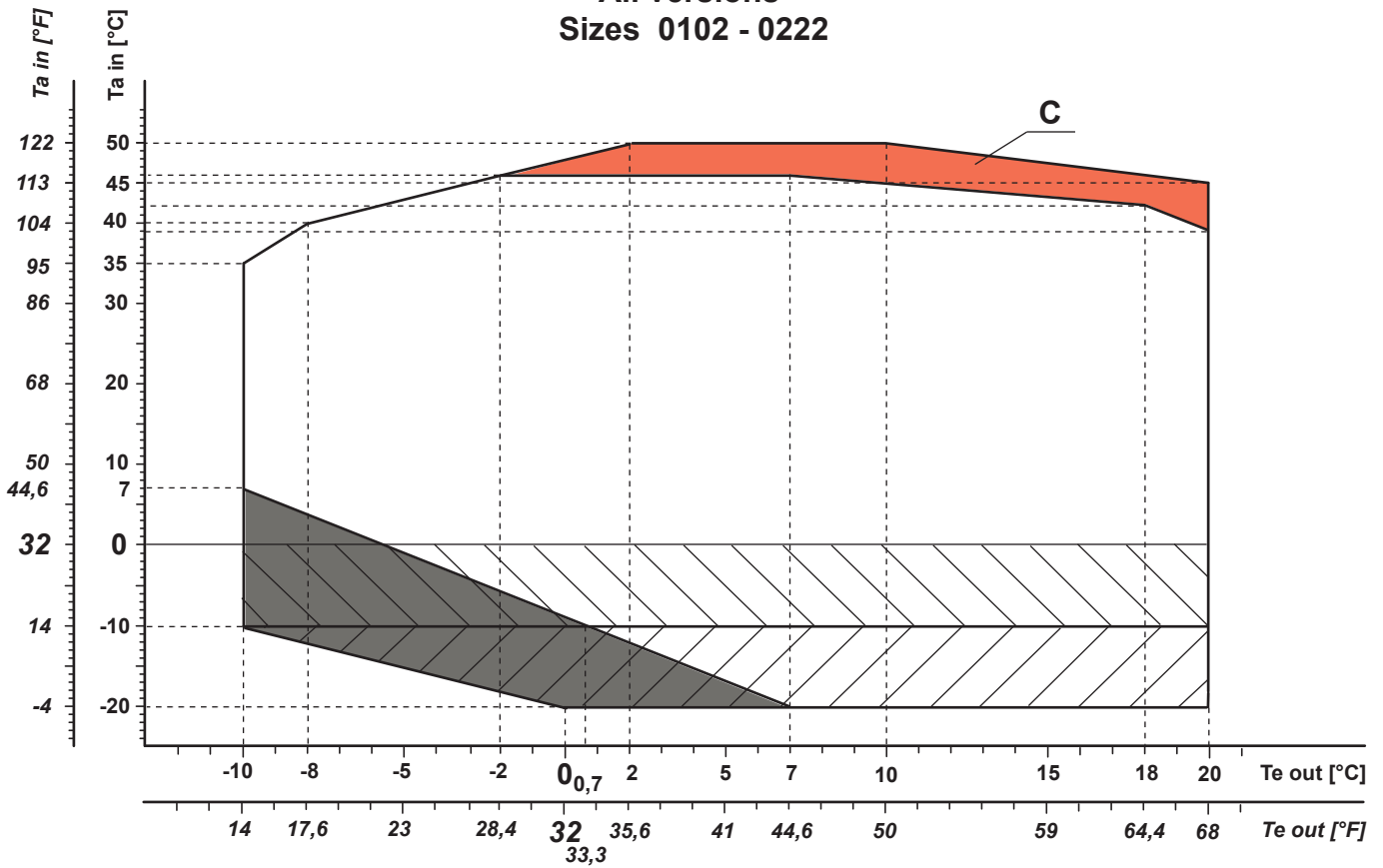

Ta in Outdoor air temperature [°C]
Te out Evaporator outlet temperature [°C]

- Version STD

- EC fans (code 808)

- Part load operation

- Antifreeze heaters on pipes, pumps* and buffer tank* (code 2432 o 2433).
(* if present)

- Operation between -10°C and -20°C of outdoor air temperature is allowed for wind protected installations (wind speed lower than 2 m/s - 6,56 ft/s)

- Extra insulation on heat exchangers, pipes, pumps* and buffer tank* (RFQ),
- Extra antifreeze heaters on heat exchangers, pipes, pumps* and buffer tank* (RFQ),
(* if present)

NOTES:

For the temperature limits of each size please refer to the selection software ElcaWorld (the diagram over 40°C could vary according to the size and the version of the selected unit).

RFQ: Request for quotation

OPERATING LIMITS

**All versions /D
Sizes 0042 - 0092**

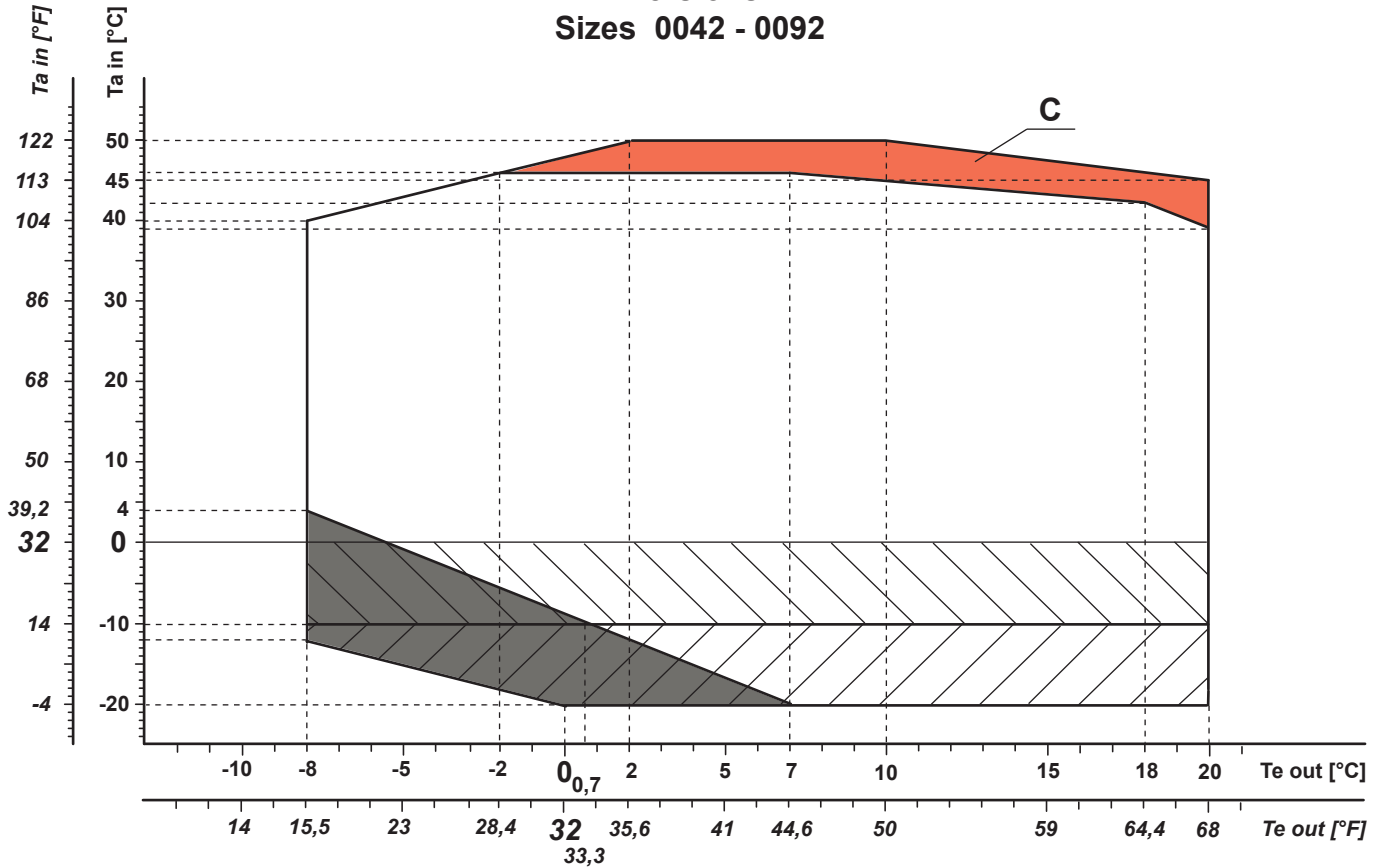

Ta in Outdoor air temperature [°C]
Te out Evaporator outlet temperature [°C]

- Version STD

- DVV2F (code 821) or EC fans (code 808)

- Part load operation

- Antifreeze heaters on pipes, pumps* and buffer tank* (code 2432 o 2433).
 (* if present)

- Operation between -10°C and -20°C of outdoor air temperature is allowed for wind protected installations
 (wind speed lower than 2 m/s - 6,56 ft/s)

- Extra insulation on heat exchangers, pipes, pumps* and buffer tank* (RFQ),
 - Extra antifreeze heaters on heat exchangers, pipes, pumps* and buffer tank* (RFQ),
 (* if present)

NOTES:

For the temperature limits of each size please refer to the selection software ElcaWorld
 (the diagram over 40°C could vary according to the size and the version of the selected unit).
 RFQ: Request for quotation

OPERATING LIMITS

**All versions /D
Sizes 0102 - 0222**

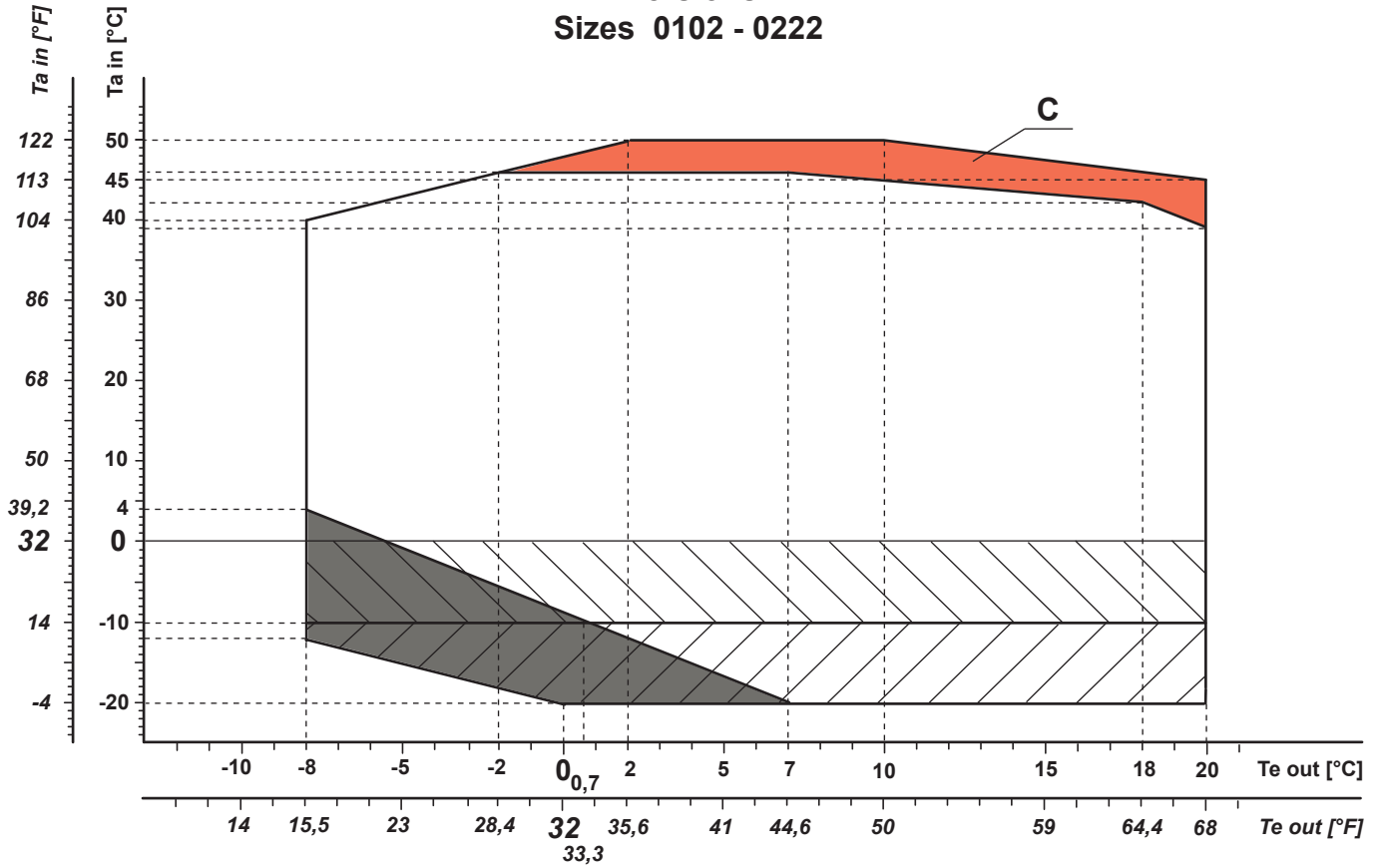

Ta in Outdoor air temperature [°C]
Te out Evaporator outlet temperature [°C]

- Version STD

- EC fans (code 808)

- Part load operation

- Antifreeze heaters on pipes, pumps* and buffer tank* (code 2432 o 2433).
 (* if present)

- Operation between -10°C and -20°C of outdoor air temperature is allowed for wind protected installations (wind speed lower than 2 m/s - 6,56 ft/s)

- Extra insulation on heat exchangers, pipes, pumps* and buffer tank* (RFQ),
 - Extra antifreeze heaters on heat exchangers, pipes, pumps* and buffer tank* (RFQ),
 (* if present)

NOTES:

For the temperature limits of each size please refer to the selection software ElcaWorld (the diagram over 40°C could vary according to the size and the version of the selected unit).
 RFQ: Request for quotation

OPERATING LIMITS

NX2-G06 0042 - 0222

SIZE	
NX2-G06 /0042	NX2-G06 /D /0222
NX2-G06 /0052	NX2-G06 /0042
NX2-G06 /0062	NX2-G06 /0052
NX2-G06 /0072	NX2-G06 /0062
NX2-G06 /0082	NX2-G06 /0072
NX2-G06 /0092	NX2-G06 /0082
NX2-G06 /0102	NX2-G06 /0092
NX2-G06 /0112	NX2-G06 /0102
NX2-G06 /0122	NX2-G06 /0112
NX2-G06 /0142	NX2-G06 /0122
NX2-G06 /0162	NX2-G06 /0142
NX2-G06 /0182	NX2-G06 /0162
NX2-G06 /0202	NX2-G06 /0182
NX2-G06 /0222	NX2-G06 /0202
NX2-G06 /D /0042	NX2-G06 /0222
NX2-G06 /D /0052	NX2-G06 /D /0042
NX2-G06 /D /0062	NX2-G06 /D /0052
NX2-G06 /D /0072	NX2-G06 /D /0062
NX2-G06 /D /0082	NX2-G06 /D /0072
NX2-G06 /D /0092	NX2-G06 /D /0082
NX2-G06 /D /0102	NX2-G06 /D /0092
NX2-G06 /D /0112	NX2-G06 /D /0102
NX2-G06 /D /0122	NX2-G06 /D /0112
NX2-G06 /D /0142	NX2-G06 /D /0122
NX2-G06 /D /0162	NX2-G06 /D /0142
NX2-G06 /D /0182	NX2-G06 /D /0162
NX2-G06 /D /0202	NX2-G06 /D /0182
NX2-G06 /D /0222	NX2-G06 /D /0202
NX2-G06 /0042	NX2-G06 /D /0222
NX2-G06 /0052	
NX2-G06 /0062	
NX2-G06 /0072	
NX2-G06 /0082	
NX2-G06 /0092	
NX2-G06 /0102	
NX2-G06 /0112	
NX2-G06 /0122	
NX2-G06 /0142	
NX2-G06 /0162	
NX2-G06 /0182	
NX2-G06 /0202	
NX2-G06 /0222	
NX2-G06 /D /0042	
NX2-G06 /D /0052	
NX2-G06 /D /0062	
NX2-G06 /D /0072	
NX2-G06 /D /0082	
NX2-G06 /D /0092	
NX2-G06 /D /0102	
NX2-G06 /D /0112	
NX2-G06 /D /0122	
NX2-G06 /D /0142	
NX2-G06 /D /0162	
NX2-G06 /D /0182	
NX2-G06 /D /0202	

7.2 ETHYLENE GLYCOL MIXTURE

Ethylene glycol and water mixture, used as a heat-conveying fluid, cause a variation in unit performance. For correct data, use the factors indicated in the following tabel.

	Freezing point (°C)							
	0	-5	-10	-15	-20	-25	-30	-35
	Ethylene glycol percentage by weight							
	0%	12%	20%	30%	35%	40%	45%	50%
cPf	1	0,985	0,98	0,974	0,97	0,965	0,964	0,96
cQ	1	1,02	1,04	1,075	1,11	1,14	1,17	1,2
cdp	1	1,07	1,11	1,18	1,22	1,24	1,27	1,3

cPf: cooling power correction factor
cQ: flow correction factor
cdp: pressure drop correction factor

For data concerning other kind of anti-freeze solutions (e.g. propylene glycol) please contact our Sale Department.

7.3 FOULING FACTORS

Performances are based on clean condition of tubes (fouling factor = 1). For different fouling values, performance should be adjusted using the correction factors shown in the following table.

SERIES	FOULING FACTORS	EVAPORATOR			CONDENSER/RECOVERY			DESUPERHEATER
	ff (m ² °CW)	F1	FK1	KE [°C]	F2	FK2	KC [°C]	R3
VARIOUS	0	1,000	1,000	0,0	1,000	1,000	0,0	1,000
VARIOUS	1,80 x 10 ⁻⁵	1,000	1,000	0,0	1,000	1,000	0,0	1,000
VARIOUS	4,40 x 10 ⁻⁵	1,000	1,000	0,0	0,990	1,030	1,0	0,990
VARIOUS	8,80 x 10 ⁻⁵	0,960	0,990	0,7	0,980	1,040	1,5	0,980
VARIOUS	13,20 x 10 ⁻⁵	0,944	0,985	1,0	0,964	1,050	2,3	0,964
VARIOUS	17,20 x 10 ⁻⁵	0,930	0,980	1,5	0,950	1,060	3,0	0,950

ff: fouling factors

F1 - F2: potential correction factors

FK1 - FK2: compressor power input correction factors

R3: capacity correction factors

KE: minimum evaporator outlet temperature increase

KC: maximum condenser outlet temperature decrease

8.1 HYDRAULIC DATA

[SI System]

Water flow and pressure drop

Water flow in the plant (side) exchanger is given by:

$$Q = P / (4,186 \times Dt)$$

Q: water flow (l/s)

Dt: difference between inlet and outlet water temp. (°C)

P: heat exchanger capacity (kW)

Pressure drop is given by:

$$Dp = K \times (3,6 \times Q)^2 / 1000$$

Q: water flow (l/s)

Dp: pressure drop (kPa)

K: unit size ratio

SIZE	Power supply V/ph/Hz	HEAT EXCHANGER USER SIDE					HEAT RECOVERY EX. USER SIDE			
		K	Q min l/s	Q max l/s	C.A.S. l	C.a. min l	K	Q min l/s	Q max l/s	C.A.S. l
NX2-G06 /0042	400/3+N/50	920	1,167	3,500	2,40	109	-	-	-	-
NX2-G06 /0052	400/3+N/50	476	1,389	4,111	3,50	130	-	-	-	-
NX2-G06 /0062	400/3+N/50	476	1,583	4,667	3,50	145	-	-	-	-
NX2-G06 /0072	400/3+N/50	412	1,778	5,278	3,80	165	-	-	-	-
NX2-G06 /0082	400/3+N/50	335	2,000	5,833	4,30	182	-	-	-	-
NX2-G06 /0092	400/3+N/50	240	2,333	6,111	5,20	216	-	-	-	-
NX2-G06 /0102	400/3/50	142	2,722	7,917	6,80	251	-	-	-	-
NX2-G06 /0112	400/3/50	142	3,056	8,889	6,80	278	-	-	-	-
NX2-G06 /0122	400/3/50	113	3,417	10,03	7,60	314	-	-	-	-
NX2-G06 /0142	400/3/50	85,5	3,778	11,22	8,80	351	-	-	-	-
NX2-G06 /0162	400/3/50	70,0	4,472	13,06	9,80	409	-	-	-	-
NX2-G06 /0182	400/3/50	49,0	5,111	14,17	12,0	468	-	-	-	-
NX2-G06 /0202	400/3/50	37,2	5,472	14,17	14,2	502	-	-	-	-
NX2-G06 /0222	400/3/50	37,2	6,139	14,17	14,2	565	-	-	-	-
NX2-G06 /D /0042	400/3+N/50	920	1,167	3,500	2,40	109	1767	-	0,778	0,44
NX2-G06 /D /0052	400/3+N/50	476	1,389	4,111	3,50	130	1767	-	0,944	0,44
NX2-G06 /D /0062	400/3+N/50	476	1,583	4,667	3,50	145	1767	-	1,028	0,44
NX2-G06 /D /0072	400/3+N/50	412	1,778	5,278	3,80	165	1767	-	1,056	0,44
NX2-G06 /D /0082	400/3+N/50	335	2,000	5,833	4,30	182	1767	-	1,222	0,44
NX2-G06 /D /0092	400/3+N/50	240	2,333	6,111	5,20	216	871	-	1,500	0,63
NX2-G06 /D /0102	400/3/50	142	2,722	7,917	6,80	251	871	-	1,583	0,63
NX2-G06 /D /0112	400/3/50	142	3,056	8,889	6,80	278	871	-	1,861	0,63
NX2-G06 /D /0122	400/3/50	113	3,417	10,03	7,60	314	613	-	2,222	0,76
NX2-G06 /D /0142	400/3/50	85,5	3,778	11,22	8,80	351	613	-	2,667	0,76
NX2-G06 /D /0162	400/3/50	70,0	4,472	13,06	9,80	409	412	-	2,750	0,95
NX2-G06 /D /0182	400/3/50	49,0	5,111	14,17	12,0	468	412	-	3,250	0,95
NX2-G06 /D /0202	400/3/50	37,2	5,472	14,17	14,2	502	277	-	3,611	1,26
NX2-G06 /D /0222	400/3/50	37,2	6,139	14,17	14,2	565	277	-	4,306	1,26
NX2-G06 /0042	400/3+N/50	920	1,167	3,500	2,40	109	-	-	-	-
NX2-G06 /0052	400/3+N/50	476	1,389	4,111	3,50	130	-	-	-	-
NX2-G06 /0062	400/3+N/50	476	1,583	4,667	3,50	145	-	-	-	-
NX2-G06 /0072	400/3+N/50	412	1,778	5,278	3,80	165	-	-	-	-
NX2-G06 /0082	400/3+N/50	335	2,000	5,833	4,30	182	-	-	-	-
NX2-G06 /0092	400/3+N/50	240	2,333	6,111	5,20	216	-	-	-	-
NX2-G06 /0102	400/3/50	142	2,722	7,917	6,80	251	-	-	-	-
NX2-G06 /0112	400/3/50	142	3,056	8,889	6,80	278	-	-	-	-
NX2-G06 /0122	400/3/50	113	3,417	10,03	7,60	314	-	-	-	-
NX2-G06 /0142	400/3/50	85,5	3,778	11,22	8,80	351	-	-	-	-
NX2-G06 /0162	400/3/50	70,0	4,472	13,06	9,80	409	-	-	-	-
NX2-G06 /0182	400/3/50	49,0	5,111	14,17	12,0	468	-	-	-	-
NX2-G06 /0202	400/3/50	37,2	5,472	14,17	14,2	502	-	-	-	-

Q min: minimum water flow admitted to the heat exchanger
 Q max: maximum water flow admitted to the heat exchanger
 C.a. min: minimum water content admitted in the plant
 C.A.S.: Exchanger water content

HYDRAULIC DATA

[SI System]

SIZE	Power supply V/ph/Hz	HEAT EXCHANGER USER SIDE					HEAT RECOVERY EX. USER SIDE			
		K	Q min l/s	Q max l/s	C.A.S. l	C.a. min l	K	Q min l/s	Q max l/s	C.A.S. l
NX2-G06 /0222	400/3/50	37,2	6,139	14,17	14,2	565	-	-	-	-
NX2-G06 /D /0042	400/3+N/50	920	1,167	3,500	2,40	109	1767	-	0,778	0,44
NX2-G06 /D /0052	400/3+N/50	476	1,389	4,111	3,50	130	1767	-	0,944	0,44
NX2-G06 /D /0062	400/3+N/50	476	1,583	4,667	3,50	145	1767	-	1,028	0,44
NX2-G06 /D /0072	400/3+N/50	412	1,778	5,278	3,80	165	1767	-	1,056	0,44
NX2-G06 /D /0082	400/3+N/50	335	2,000	5,833	4,30	182	1767	-	1,222	0,44
NX2-G06 /D /0092	400/3+N/50	240	2,333	6,111	5,20	216	871	-	1,500	0,63
NX2-G06 /D /0102	400/3/50	142	2,722	7,917	6,80	251	871	-	1,583	0,63
NX2-G06 /D /0112	400/3/50	142	3,056	8,889	6,80	278	871	-	1,861	0,63
NX2-G06 /D /0122	400/3/50	113	3,417	10,03	7,60	314	613	-	2,222	0,76
NX2-G06 /D /0142	400/3/50	85,5	3,778	11,22	8,80	351	613	-	2,667	0,76
NX2-G06 /D /0162	400/3/50	70,0	4,472	13,06	9,80	409	412	-	2,750	0,95
NX2-G06 /D /0182	400/3/50	49,0	5,111	14,17	12,0	468	412	-	3,250	0,95
NX2-G06 /D /0202	400/3/50	37,2	5,472	14,17	14,2	502	277	-	3,611	1,26
NX2-G06 /D /0222	400/3/50	37,2	6,139	14,17	14,2	565	277	-	4,306	1,26
NX2-G06 /0042	400/3+N/50	920	1,167	3,500	2,40	109	-	-	-	-
NX2-G06 /0052	400/3+N/50	476	1,389	4,111	3,50	130	-	-	-	-
NX2-G06 /0062	400/3+N/50	476	1,583	4,667	3,50	145	-	-	-	-
NX2-G06 /0072	400/3+N/50	412	1,778	5,278	3,80	165	-	-	-	-
NX2-G06 /0082	400/3+N/50	335	2,000	5,833	4,30	182	-	-	-	-
NX2-G06 /0092	400/3+N/50	240	2,333	6,111	5,20	216	-	-	-	-
NX2-G06 /0102	400/3/50	142	2,722	7,917	6,80	251	-	-	-	-
NX2-G06 /0112	400/3/50	142	3,056	8,889	6,80	278	-	-	-	-
NX2-G06 /0122	400/3/50	113	3,417	10,03	7,60	314	-	-	-	-
NX2-G06 /0142	400/3/50	85,5	3,778	11,22	8,80	351	-	-	-	-
NX2-G06 /0162	400/3/50	70,0	4,472	13,06	9,80	409	-	-	-	-
NX2-G06 /0182	400/3/50	49,0	5,111	14,17	12,0	468	-	-	-	-
NX2-G06 /0202	400/3/50	37,2	5,472	14,17	14,2	502	-	-	-	-
NX2-G06 /0222	400/3/50	37,2	6,139	14,17	14,2	565	-	-	-	-
NX2-G06 /D /0042	400/3+N/50	920	1,167	3,500	2,40	109	1767	-	0,778	0,44
NX2-G06 /D /0052	400/3+N/50	476	1,389	4,111	3,50	130	1767	-	0,944	0,44
NX2-G06 /D /0062	400/3+N/50	476	1,583	4,667	3,50	145	1767	-	1,028	0,44
NX2-G06 /D /0072	400/3+N/50	412	1,778	5,278	3,80	165	1767	-	1,056	0,44
NX2-G06 /D /0082	400/3+N/50	335	2,000	5,833	4,30	182	1767	-	1,222	0,44
NX2-G06 /D /0092	400/3+N/50	240	2,333	6,111	5,20	216	871	-	1,500	0,63
NX2-G06 /D /0102	400/3/50	142	2,722	7,917	6,80	251	871	-	1,583	0,63
NX2-G06 /D /0112	400/3/50	142	3,056	8,889	6,80	278	871	-	1,861	0,63
NX2-G06 /D /0122	400/3/50	113	3,417	10,03	7,60	314	613	-	2,222	0,76
NX2-G06 /D /0142	400/3/50	85,5	3,778	11,22	8,80	351	613	-	2,667	0,76
NX2-G06 /D /0162	400/3/50	70,0	4,472	13,06	9,80	409	412	-	2,750	0,95
NX2-G06 /D /0182	400/3/50	49,0	5,111	14,17	12,0	468	412	-	3,250	0,95
NX2-G06 /D /0202	400/3/50	37,2	5,472	14,17	14,2	502	277	-	3,611	1,26
NX2-G06 /D /0222	400/3/50	37,2	6,139	14,17	14,2	565	277	-	4,306	1,26

Q min: minimum water flow admitted to the heat exchanger
 Q max: maximum water flow admitted to the heat exchanger
 C.a. min: minimum water content admitted in the plant
 C.A.S.: Exchanger water content

9.1 ELECTRICAL DATA

NX2-G06

[SI System]

SIZE	Power supply V/ph/Hz	Maximum values								
		n	Compressor			Fans (1)		Total (1)(2)		
			F.L.I. [kW]	F.L.A. [A]	L.R.A. [A]	F.L.I. [kW]	F.L.A. [A]	F.L.I. [kW]	F.L.A. [A]	S.A. [A]
0042	400/3+N/50	2	2 x 9,1	2 x 15,6	2 x 98	0,300	1	19,40	36	118
0052	400/3+N/50	2	2 x 10,5	2 x 18,1	2 x 142	0,300	1	22,20	41	165
0062	400/3+N/50	2	2 x 11,5	2 x 18,1	2 x 123	0,300	1	24,20	41	146
0072	400/3+N/50	2	2 x 12,9	2 x 20,4	2 x 138	0,300	1	27,60	47	165
0082	400/3+N/50	2	2 x 14,4	2 x 22,9	2 x 145	0,300	1	30,60	52	175
0092	400/3+N/50	2	2 x 16,7	2 x 26,9	2 x 172	0,300	1	35,20	60	206
0102	400/3/50	2	1 x 16,7 + 1 x 22,4	1 x 26,9 + 1 x 35,6	1 x 172 + 1 x 211	2,000	4	43,10	71	246
0112	400/3/50	2	2 x 22,4	2 x 35,6	2 x 211	2,000	4	48,80	79	255
0122	400/3/50	2	1 x 22,4 + 1 x 30,5	1 x 35,6 + 1 x 48	1 x 211 + 1 x 210	2,000	4	56,90	92	255
0142	400/3/50	2	2 x 30,5	2 x 48	2 x 210	2,000	4	65,00	104	266
0162	400/3/50	2	1 x 30,5 + 1 x 38	1 x 48 + 1 x 61	1 x 210 + 1 x 326	2,000	4	74,50	121	386
0182	400/3/50	2	2 x 38	2 x 61	2 x 326	2,000	4	82,00	134	399
0202	400/3/50	2	2 x 42,8	2 x 70,2	2 x 326	2,000	4	91,60	152	408
0222	400/3/50	2	2 x 46,4	2 x 75,6	2 x 295	2,000	4	98,80	163	383

F.L.I.: Full load power

F.L.A.: Full load current

L.R.A.: Locked rotor amperes for single compressor

S.A.: Inrush current

(1) Values calculated referring to the version with the maximum number of fans working at the max absorbed current

(1)(2) Safety values to be considered when cabling the unit for power supply and line-protections

Data valid for standard units without any additional option.

Plant (side) cooling exchanger water (in/out) 12,00°C/7,00°C; Source (side) heat exchanger air (in) 35,0°C.

Voltage tolerance: 10%

Maximum voltage unbalance: 2%

Give the typical operating conditions of units designed for outdoor installation, which can be associated (according to reference document IEC 60721) to the following classes:

- climatic conditions class 4K4H: air temperature range from -20 up to 55°C (*), relative humidity range from 4 up to 100%, with possible precipitations, at air pressure from 70 and 106 kPa and a maximum solar radiation of 1120 W/m²

- special climatic conditions negligible

- biological conditions class 4B1 and 4C2: locations in a generic urban area

- mechanically active substances class 4S2: locations in areas with sand or dust representative of urban areas

- mechanical conditions class 4M1: locations protected from significant vibrations or shocks

The required protection level for safe operation, according to reference document IEC 60529, is IP43XW (protection against access, to the most critical unit's parts, of external devices with diameter larger than 1 mm and rain).

The unit can be considered IP44XW protected, i.e. protected against access of external devices (with diameter larger than 1 mm) and water in general.

(*) for the unit's operating limits, see "selection limits" section

ELECTRICAL DATA

NX2-G06 + UP kit

[SI System]

SIZE	Power supply V/ph/Hz	Maximum values								
		n	Compressor			Fans (1)		Total (1)(2)		
			F.L.I. [kW]	F.L.A. [A]	L.R.A. [A]	F.L.I. [kW]	F.L.A. [A]	F.L.I. [kW]	F.L.A. [A]	S.A. [A]
0042	400/3+N/50	2	2 x 9,1	2 x 15,6	2 x 98	0,300	1	19,40	36	118
0052	400/3+N/50	2	2 x 10,5	2 x 18,1	2 x 142	0,300	1	22,20	41	165
0062	400/3+N/50	2	2 x 11,5	2 x 18,1	2 x 123	0,300	1	24,20	41	146
0072	400/3+N/50	2	2 x 12,9	2 x 20,4	2 x 138	0,300	1	27,60	47	165
0082	400/3+N/50	2	2 x 14,4	2 x 22,9	2 x 145	0,300	1	30,60	52	175
0092	400/3+N/50	2	2 x 16,7	2 x 26,9	2 x 172	0,300	1	35,20	60	206
0102	400/3/50	2	1 x 16,7 + 1 x 22,4	1 x 26,9 + 1 x 35,6	1 x 172 + 1 x 211	2,000	4	43,10	71	246
0112	400/3/50	2	2 x 22,4	2 x 35,6	2 x 211	2,000	4	48,80	79	255
0122	400/3/50	2	1 x 22,4 + 1 x 30,5	1 x 35,6 + 1 x 48	1 x 211 + 1 x 210	2,000	4	56,90	92	255
0142	400/3/50	2	2 x 30,5	2 x 48	2 x 210	2,000	4	65,00	104	266
0162	400/3/50	2	1 x 30,5 + 1 x 38	1 x 48 + 1 x 61	1 x 210 + 1 x 326	2,000	4	74,50	121	386
0182	400/3/50	2	2 x 38	2 x 61	2 x 326	2,000	4	82,00	134	399
0202	400/3/50	2	2 x 42,8	2 x 70,2	2 x 326	2,000	4	91,60	152	408
0222	400/3/50	2	2 x 46,4	2 x 75,6	2 x 295	2,000	4	98,80	163	383

F.L.I.: Full load power

F.L.A.: Full load current

L.R.A.: Locked rotor amperes for single compressor

S.A.: Inrush current

(1) Values calculated referring to the version with the maximum number of fans working at the max absorbed current

(1)(2) Safety values to be considered when cabling the unit for power supply and line-protections

Data valid for standard units without any additional option.

Plant (side) cooling exchanger water (in/out) 12,00°C/7,00°C; Source (side) heat exchanger air (in) 35,0°C.

Voltage tolerance: 10%

Maximum voltage unbalance: 2%

Give the typical operating conditions of units designed for outdoor installation, which can be associated (according to reference document IEC 60721) to the following classes:

- climatic conditions class 4K4H: air temperature range from -20 up to 55°C (*), relative humidity range from 4 up to 100%, with possible precipitations, at air pressure from 70 and 106 kPa and a maximum solar radiation of 1120 W/m2

- special climatic conditions negligible

- biological conditions class 4B1 and 4C2: locations in a generic urban area

- mechanically active substances class 4S2: locations in areas with sand or dust representative of urban areas

- mechanical conditions class 4M1: locations protected from significant vibrations or shocks

The required protection level for safe operation, according to reference document IEC 60529, is IP43XW (protection against access, to the most critical unit's parts, of external devices with diameter larger than 1 mm and rain).

The unit can be considered IP44XW protected, i.e. protected against access of external devices (with diameter larger than 1 mm) and water in general.

(*) for the unit's operating limits, see "selection limits" section

ELECTRICAL DATA

NX2-G06 + NR kit

[SI System]

SIZE	Power supply V/ph/Hz	Maximum values								
		n	Compressor			Fans (1)		Total (1)(2)		
			F.L.I. [kW]	F.L.A. [A]	L.R.A. [A]	F.L.I. [kW]	F.L.A. [A]	F.L.I. [kW]	F.L.A. [A]	S.A. [A]
0042	400/3+N/50	2	2 x 9,1	2 x 15,6	2 x 98	0,300	1	19,40	36	118
0052	400/3+N/50	2	2 x 10,5	2 x 18,1	2 x 142	0,300	1	22,20	41	165
0062	400/3+N/50	2	2 x 11,5	2 x 18,1	2 x 123	0,300	1	24,20	41	146
0072	400/3+N/50	2	2 x 12,9	2 x 20,4	2 x 138	0,300	1	27,60	47	165
0082	400/3+N/50	2	2 x 14,4	2 x 22,9	2 x 145	0,300	1	30,60	52	175
0092	400/3+N/50	2	2 x 16,7	2 x 26,9	2 x 172	0,300	1	35,20	60	206
0102	400/3/50	2	1 x 16,7 + 1 x 22,4	1 x 26,9 + 1 x 35,6	1 x 172 + 1 x 211	2,000	4	43,10	71	246
0112	400/3/50	2	2 x 22,4	2 x 35,6	2 x 211	2,000	4	48,80	79	255
0122	400/3/50	2	1 x 22,4 + 1 x 30,5	1 x 35,6 + 1 x 48	1 x 211 + 1 x 210	2,000	4	56,90	92	255
0142	400/3/50	2	2 x 30,5	2 x 48	2 x 210	2,000	4	65,00	104	266
0162	400/3/50	2	1 x 30,5 + 1 x 38	1 x 48 + 1 x 61	1 x 210 + 1 x 326	2,000	4	74,50	121	386
0182	400/3/50	2	2 x 38	2 x 61	2 x 326	2,000	4	82,00	134	399
0202	400/3/50	2	2 x 42,8	2 x 70,2	2 x 326	2,000	4	91,60	152	408
0222	400/3/50	2	2 x 46,4	2 x 75,6	2 x 295	2,000	4	98,80	163	383

F.L.I.: Full load power

F.L.A.: Full load current

L.R.A.: Locked rotor amperes for single compressor

S.A.: Inrush current

(1) Values calculated referring to the version with the maximum number of fans working at the max absorbed current

(1)(2) Safety values to be considered when cabling the unit for power supply and line-protections

Data valid for standard units without any additional option.

Plant (side) cooling exchanger water (in/out) 12,00°C/7,00°C; Source (side) heat exchanger air (in) 35,0°C.

Voltage tolerance: 10%

Maximum voltage unbalance: 2%

Give the typical operating conditions of units designed for outdoor installation, which can be associated (according to reference document IEC 60721) to the following classes:

- climatic conditions class 4K4H: air temperature range from -20 up to 55°C (*), relative humidity range from 4 up to 100%, with possible precipitations, at air pressure from 70 and 106 kPa and a maximum solar radiation of 1120 W/m2

- special climatic conditions negligible

- biological conditions class 4B1 and 4C2: locations in a generic urban area

- mechanically active substances class 4S2: locations in areas with sand or dust representative of urban areas

- mechanical conditions class 4M1: locations protected from significant vibrations or shocks

The required protection level for safe operation, according to reference document IEC 60529, is IP43XW (protection against access, to the most critical unit's parts, of external devices with diameter larger than 1 mm and rain).

The unit can be considered IP44XW protected, i.e. protected against access of external devices (with diameter larger than 1 mm) and water in general.

(*) for the unit's operating limits, see "selection limits" section

ELECTRICAL DATA

MAIN SWITCH TYPE AND SHORT TIME CURRENT STANDARD UNITS

Unit size	Main switch type	lcw (0,25s) Short time current rms
		[kA]
0042	VC1P 4x63A	10
0052	VC1P 4x63A	10
0062	VC1P 4x100A	10
0072	VC1P 4x100A	10
0082	VC1P 4x100A	10
0092	VC1P 4x100A	10
0102	VC1P 3x125A	10
0112	VC2P 3x160A	16
0122	VC2P 3x160A	16
0142	VC2P 3x160A	16
0162	VC2P 3x160A	16
0182	VC2P 3x200A	16
0202	VC2P 3x200A	16
0222	VC2P 3x200A	16

Electrical data valid for standard units without any additional option

Voltage tolerance: 10%

Maximum voltage unbalance: 2%

10.1 FULL LOAD SOUND LEVEL

NX2-G06

SOUND POWER LEVEL IN COOLING									
SIZE	Octave band [Hz]								Total sound level dB(A)
	63	125	250	500	1000	2000	4000	8000	
	Sound power level dB								
0042	82	82	79	78	77	73	67	52	81
0052	83	83	80	79	78	74	68	53	82
0062	82	82	79	78	77	73	67	52	81
0072	84	84	81	80	79	75	69	54	83
0082	85	85	82	81	80	76	70	55	84
0092	85	85	82	81	80	76	70	55	84
0102	86	84	85	84	78	73	67	61	84
0112	86	84	85	84	78	73	67	61	84
0122	86	84	85	84	78	73	67	61	84
0142	87	85	86	85	79	74	68	62	85
0162	87	88	86	85	81	76	69	64	86
0182	88	89	87	86	82	77	70	65	87
0202	88	89	87	86	82	77	70	65	87
0222	89	90	88	87	83	78	71	66	88

Working conditions

Plant (side) cooling exchanger water (in/out) 12,00°C/7,00°C; Source (side) heat exchanger air (in) 35,0°C.

Sound power on the basis of measurements taken in compliance with ISO 9614.

Such certification refers specifically to the sound Power Level in dB(A). This is therefore the only acoustic data to be considered as binding.

Sound power level in cooling, outdoors.

SOUND PRESSURE LEVEL									
SIZE	Octave band [Hz]								Total sound level dB(A)
	63	125	250	500	1000	2000	4000	8000	
	Sound pressure level dB								
0042	50	50	47	46	45	41	35	20	49
0052	51	51	48	47	46	42	36	21	50
0062	50	50	47	46	45	41	35	20	49
0072	52	52	49	48	47	43	37	22	51
0082	53	53	50	49	48	44	38	23	52
0092	53	53	50	49	48	44	38	23	52
0102	54	52	53	52	46	41	35	29	52
0112	54	52	53	52	46	41	35	29	52
0122	54	52	53	52	46	41	35	29	52
0142	55	53	54	53	47	42	36	30	53
0162	55	56	54	53	49	44	37	32	54
0182	56	57	55	54	50	45	38	33	55
0202	56	57	55	54	50	45	38	33	55
0222	57	58	56	55	51	46	39	34	56

Working conditions

Plant (side) cooling exchanger water (in/out) 12,00°C/7,00°C; Source (side) heat exchanger air (in) 35,0°C.

Average sound pressure level at 10m distance, unit in a free field on a reflective surface; non-binding value calculated from the sound power level.

FULL LOAD SOUND LEVEL

NX2-G06 + UP kit

SOUND POWER LEVEL IN COOLING									
SIZE	Octave band [Hz]								Total sound level dB(A)
	63	125	250	500	1000	2000	4000	8000	
	Sound power level dB								
0042	86	86	82	81	81	78	70	58	85
0052	86	86	82	81	81	78	70	58	85
0062	86	86	82	81	81	78	70	58	85
0072	91	85	84	83	82	79	72	63	86
0082	92	86	85	84	83	80	73	64	87
0092	92	86	85	84	83	80	73	64	87
0102	90	90	86	85	85	82	74	62	89
0112	90	90	86	85	85	82	74	62	89
0122	90	90	86	85	85	82	74	62	89
0142	91	91	87	86	86	83	75	63	90
0162	91	93	89	88	87	83	76	68	91
0182	91	93	89	88	87	83	76	68	91
0202	91	93	89	88	87	83	76	68	91
0222	92	94	90	89	88	84	77	69	92

Working conditions

Plant (side) cooling exchanger water (in/out) 12,00°C/7,00°C; Source (side) heat exchanger air (in) 35,0°C.

Sound power on the basis of measurements taken in compliance with ISO 9614.

Such certification refers specifically to the sound Power Level in dB(A). This is therefore the only acoustic data to be considered as binding.

Sound power level in cooling, outdoors.

SOUND PRESSURE LEVEL									
SIZE	Octave band [Hz]								Total sound level dB(A)
	63	125	250	500	1000	2000	4000	8000	
	Sound pressure level dB								
0042	54	54	50	49	49	46	38	26	53
0052	54	54	50	49	49	46	38	26	53
0062	54	54	50	49	49	46	38	26	53
0072	59	53	52	51	50	47	40	31	54
0082	60	54	53	52	51	48	41	32	55
0092	60	54	53	52	51	48	41	32	55
0102	58	58	54	53	53	50	42	30	57
0112	58	58	54	53	53	50	42	30	57
0122	58	58	54	53	53	50	42	30	57
0142	59	59	55	54	54	51	43	31	58
0162	59	61	57	56	55	51	44	36	59
0182	59	61	57	56	55	51	44	36	59
0202	59	61	57	56	55	51	44	36	59
0222	60	62	58	57	56	52	45	37	60

Working conditions

Plant (side) cooling exchanger water (in/out) 12,00°C/7,00°C; Source (side) heat exchanger air (in) 35,0°C.

Average sound pressure level at 10m distance, unit in a free field on a reflective surface; non-binding value calculated from the sound power level.

FULL LOAD SOUND LEVEL

NX2-G06 + NR kit

SOUND POWER LEVEL IN COOLING									
SIZE	Octave band [Hz]								Total sound level dB(A)
	63	125	250	500	1000	2000	4000	8000	
	Sound power level dB								
0042	78	78	75	74	73	69	63	48	77
0052	79	79	76	75	74	70	64	49	78
0062	78	78	75	74	73	69	63	48	77
0072	80	80	77	76	75	71	65	50	79
0082	81	81	78	77	76	72	66	51	80
0092	81	81	78	77	76	72	66	51	80
0102	82	80	81	80	74	69	63	57	80
0112	82	80	81	80	74	69	63	57	80
0122	82	80	81	80	74	69	63	57	80
0142	84	82	83	82	76	71	65	59	82
0162	85	87	83	81	76	72	66	62	82
0182	86	88	84	82	77	73	67	63	83
0202	86	88	84	82	77	73	67	63	83
0222	87	89	85	83	78	74	68	64	84

Working conditions

Plant (side) cooling exchanger water (in/out) 12,00°C/7,00°C; Source (side) heat exchanger air (in) 35,0°C.

Sound power on the basis of measurements taken in compliance with ISO 9614.

Such certification refers specifically to the sound Power Level in dB(A). This is therefore the only acoustic data to be considered as binding.

Sound power level in cooling, outdoors.

SOUND PRESSURE LEVEL									
SIZE	Octave band [Hz]								Total sound level dB(A)
	63	125	250	500	1000	2000	4000	8000	
	Sound pressure level dB								
0042	46	46	43	42	41	37	31	16	45
0052	47	47	44	43	42	38	32	17	46
0062	46	46	43	42	41	37	31	16	45
0072	48	48	45	44	43	39	33	18	47
0082	49	49	46	45	44	40	34	19	48
0092	49	49	46	45	44	40	34	19	48
0102	50	48	49	48	42	37	31	25	48
0112	50	48	49	48	42	37	31	25	48
0122	50	48	49	48	42	37	31	25	48
0142	52	50	51	50	44	39	33	27	50
0162	53	55	51	49	44	40	34	30	50
0182	54	56	52	50	45	41	35	31	51
0202	54	56	52	50	45	41	35	31	51
0222	55	57	53	51	46	42	36	32	52

Working conditions

Plant (side) cooling exchanger water (in/out) 12,00°C/7,00°C; Source (side) heat exchanger air (in) 35,0°C.

Average sound pressure level at 10m distance, unit in a free field on a reflective surface; non-binding value calculated from the sound power level.

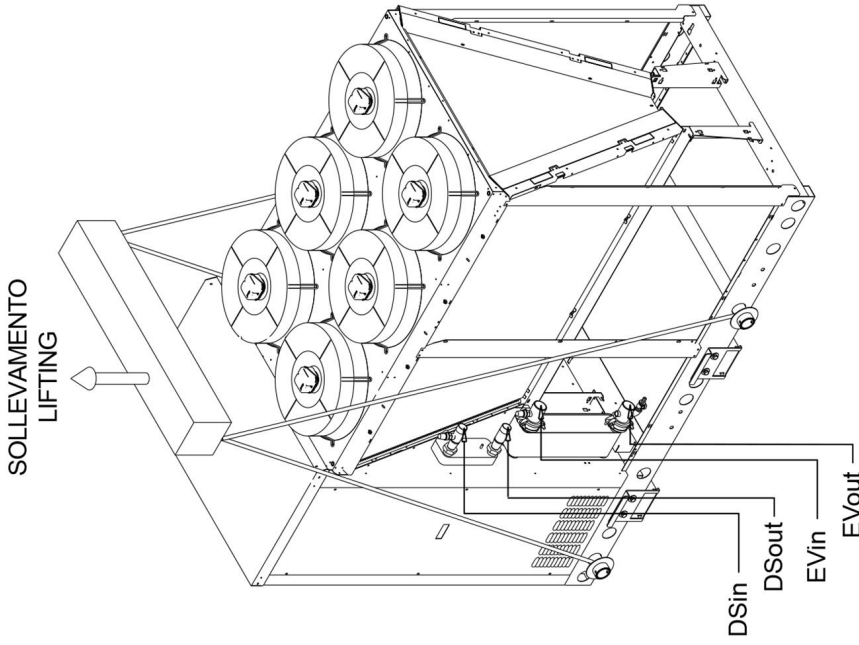

- EVin Entrata acqua evaporatore
Evaporator water inlet
- EVout Uscita acqua evaporatore
Evaporator water outlet
- DSin Entrata acqua desurriscaldatore (solo per versione /D)
Desuperheater water inlet (only for "/D" version)
- DSout Uscita acqua desurriscaldatore (solo per versione /D)
Desuperheater water outlet (only for "/D" version)

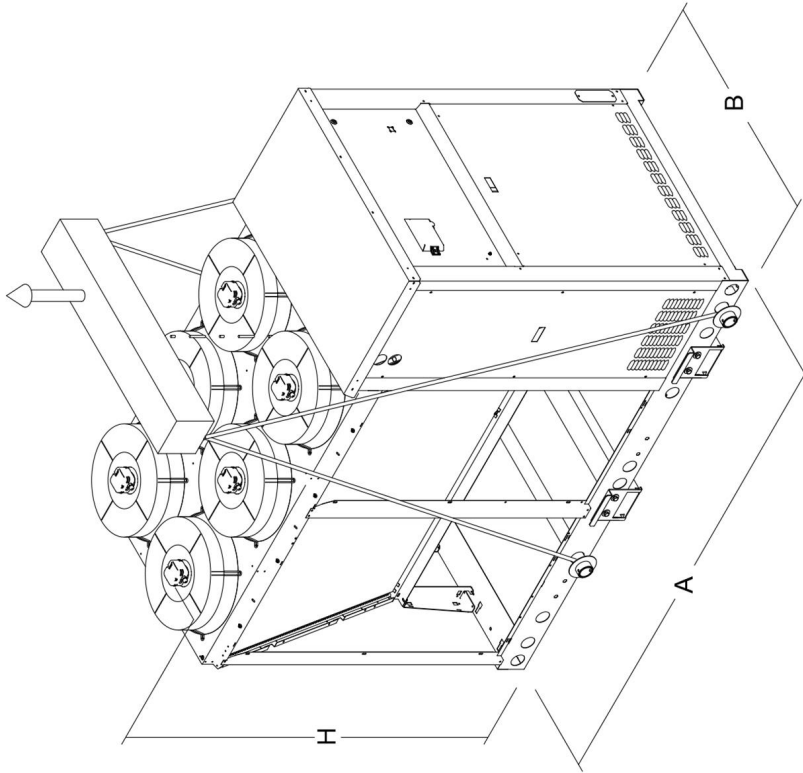

BASE D'APPOGGIO
SUPPORTING BASEMENT

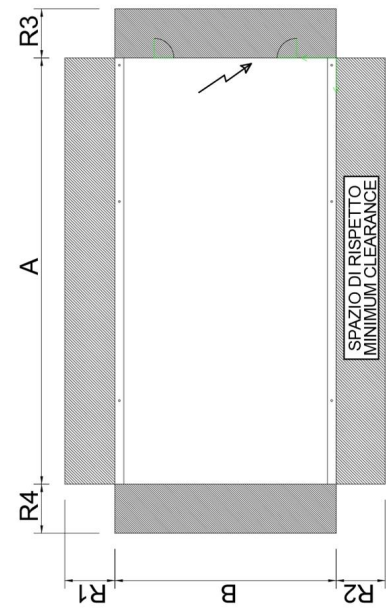

REMARKS: For installation purposes, please refer to the documentation sent after the purchase-contract. This technical data should be considered as indicative. Mitsubishi Electric Hydraulics & IT Cooling Systems S.p.A. may modify them at any moment. Data valid for standard units without any additional option.

DIMENSIONAL DRAWINGS

NX2-G06 0042 - 0222

[SI System]

SIZE	DIMENSIONS AND WEIGHTS				CLEARANCE				HEAT EXCHANGER USER SIDE		HEAT RECOVERY EX. USER SIDE	
	A	B	H	WEIGHT	R1	R2	R3	R4	IN/OUT		IN/OUT	
	[mm]	[mm]	[mm]	[kg]	[mm]	[mm]	[mm]	[mm]	TYPE	Ø	TYPE	Ø
NX2-G06 /0042	1825	1195	1865	500	1000	1000	1000	1000	B1	1"1/2	-	-
NX2-G06 /0052	1825	1195	1865	510	1000	1000	1000	1000	B1	1"1/2	-	-
NX2-G06 /0062	1825	1195	1865	550	1000	1000	1000	1000	B1	1"1/2	-	-
NX2-G06 /0072	2395	1195	1865	630	1000	1000	1000	1000	B1	2"	-	-
NX2-G06 /0082	2395	1195	1865	630	1000	1000	1000	1000	B1	2"	-	-
NX2-G06 /0092	2395	1195	1865	640	1000	1000	1000	1000	B1	2"	-	-
NX2-G06 /0102	2825	1195	1980	770	1000	1000	1000	1000	B1	2"1/2	-	-
NX2-G06 /0112	2825	1195	1980	770	1000	1000	1000	1000	B1	2"1/2	-	-
NX2-G06 /0122	2825	1195	1980	850	1000	1000	1000	1000	B1	2"1/2	-	-
NX2-G06 /0142	2825	1195	1980	920	1000	1000	1000	1000	B1	2"1/2	-	-
NX2-G06 /0162	3980	1195	1980	1130	1000	1000	1000	1000	B1	2"1/2	-	-
NX2-G06 /0182	3980	1195	1980	1170	1000	1000	1000	1000	B1	2"1/2	-	-
NX2-G06 /0202	3980	1195	1980	1180	1000	1000	1000	1000	B1	2"1/2	-	-
NX2-G06 /0222	3980	1195	1980	1220	1000	1000	1000	1000	B1	2"1/2	-	-
NX2-G06 /D /0042	1825	1195	1865	500	1000	1000	1000	1000	B1	1"1/2	B1	1"1/4
NX2-G06 /D /0052	1825	1195	1865	510	1000	1000	1000	1000	B1	1"1/2	B1	1"1/4
NX2-G06 /D /0062	1825	1195	1865	550	1000	1000	1000	1000	B1	1"1/2	B1	1"1/4
NX2-G06 /D /0072	2395	1195	1865	630	1000	1000	1000	1000	B1	2"	B1	1"1/4
NX2-G06 /D /0082	2395	1195	1865	630	1000	1000	1000	1000	B1	2"	B1	1"1/4
NX2-G06 /D /0092	2395	1195	1865	640	1000	1000	1000	1000	B1	2"	B1	1"1/4
NX2-G06 /D /0102	2825	1195	1980	770	1000	1000	1000	1000	B1	2"1/2	B1	1"1/4
NX2-G06 /D /0112	2825	1195	1980	770	1000	1000	1000	1000	B1	2"1/2	B1	1"1/4
NX2-G06 /D /0122	2825	1195	1980	850	1000	1000	1000	1000	B1	2"1/2	B1	1"1/4
NX2-G06 /D /0142	2825	1195	1980	920	1000	1000	1000	1000	B1	2"1/2	B1	1"1/4
NX2-G06 /D /0162	3980	1195	1980	1130	1000	1000	1000	1000	B1	2"1/2	B1	1"1/4
NX2-G06 /D /0182	3980	1195	1980	1170	1000	1000	1000	1000	B1	2"1/2	B1	1"1/4
NX2-G06 /D /0202	3980	1195	1980	1180	1000	1000	1000	1000	B1	2"1/2	B1	1"1/4
NX2-G06 /D /0222	3980	1195	1980	1220	1000	1000	1000	1000	B1	2"1/2	B1	1"1/4
NX2-G06 /0042	1825	1195	1865	500	1000	1000	1000	1000	B1	1"1/2	-	-
NX2-G06 /0052	1825	1195	1865	510	1000	1000	1000	1000	B1	1"1/2	-	-
NX2-G06 /0062	1825	1195	1865	550	1000	1000	1000	1000	B1	1"1/2	-	-
NX2-G06 /0072	2395	1195	1865	630	1000	1000	1000	1000	B1	2"	-	-
NX2-G06 /0082	2395	1195	1865	630	1000	1000	1000	1000	B1	2"	-	-
NX2-G06 /0092	2395	1195	1865	640	1000	1000	1000	1000	B1	2"	-	-
NX2-G06 /0102	2825	1195	1980	770	1000	1000	1000	1000	B1	2"1/2	-	-
NX2-G06 /0112	2825	1195	1980	770	1000	1000	1000	1000	B1	2"1/2	-	-
NX2-G06 /0122	2825	1195	1980	850	1000	1000	1000	1000	B1	2"1/2	-	-
NX2-G06 /0142	2825	1195	1980	920	1000	1000	1000	1000	B1	2"1/2	-	-
NX2-G06 /0162	3980	1195	1980	1130	1000	1000	1000	1000	B1	2"1/2	-	-
NX2-G06 /0182	3980	1195	1980	1170	1000	1000	1000	1000	B1	2"1/2	-	-
NX2-G06 /0202	3980	1195	1980	1180	1000	1000	1000	1000	B1	2"1/2	-	-
NX2-G06 /0222	3980	1195	1980	1220	1000	1000	1000	1000	B1	2"1/2	-	-
NX2-G06 /D /0042	1825	1195	1865	500	1000	1000	1000	1000	B1	1"1/2	B1	1"1/4
NX2-G06 /D /0052	1825	1195	1865	510	1000	1000	1000	1000	B1	1"1/2	B1	1"1/4
NX2-G06 /D /0062	1825	1195	1865	550	1000	1000	1000	1000	B1	1"1/2	B1	1"1/4
NX2-G06 /D /0072	2395	1195	1865	630	1000	1000	1000	1000	B1	2"	B1	1"1/4
NX2-G06 /D /0082	2395	1195	1865	630	1000	1000	1000	1000	B1	2"	B1	1"1/4
NX2-G06 /D /0092	2395	1195	1865	640	1000	1000	1000	1000	B1	2"	B1	1"1/4
NX2-G06 /D /0102	2825	1195	1980	770	1000	1000	1000	1000	B1	2"1/2	B1	1"1/4
NX2-G06 /D /0112	2825	1195	1980	770	1000	1000	1000	1000	B1	2"1/2	B1	1"1/4
NX2-G06 /D /0122	2825	1195	1980	850	1000	1000	1000	1000	B1	2"1/2	B1	1"1/4
NX2-G06 /D /0142	2825	1195	1980	920	1000	1000	1000	1000	B1	2"1/2	B1	1"1/4

DIMENSIONAL DRAWINGS

NX2-G06 0042 - 0222

[SI System]

SIZE	DIMENSIONS AND WEIGHTS				CLEARANCE				HEAT EXCHANGER USER SIDE		HEAT RECOVERY EX. USER SIDE	
	A	B	H	WEIGHT	R1	R2	R3	R4	IN/OUT		IN/OUT	
	[mm]	[mm]	[mm]	[kg]	[mm]	[mm]	[mm]	[mm]	TYPE	Ø	TYPE	Ø
NX2-G06 /D /0162	3980	1195	1980	1130	1000	1000	1000	1000	B1	2"1/2	B1	1"1/4
NX2-G06 /D /0182	3980	1195	1980	1170	1000	1000	1000	1000	B1	2"1/2	B1	1"1/4
NX2-G06 /D /0202	3980	1195	1980	1180	1000	1000	1000	1000	B1	2"1/2	B1	1"1/4
NX2-G06 /D /0222	3980	1195	1980	1220	1000	1000	1000	1000	B1	2"1/2	B1	1"1/4
NX2-G06 /0042	1825	1195	1865	500	1000	1000	1000	1000	B1	1"1/2	-	-
NX2-G06 /0052	1825	1195	1865	510	1000	1000	1000	1000	B1	1"1/2	-	-
NX2-G06 /0062	1825	1195	1865	550	1000	1000	1000	1000	B1	1"1/2	-	-
NX2-G06 /0072	2395	1195	1865	630	1000	1000	1000	1000	B1	2"	-	-
NX2-G06 /0082	2395	1195	1865	630	1000	1000	1000	1000	B1	2"	-	-
NX2-G06 /0092	2395	1195	1865	640	1000	1000	1000	1000	B1	2"	-	-
NX2-G06 /0102	2825	1195	1980	770	1000	1000	1000	1000	B1	2"1/2	-	-
NX2-G06 /0112	2825	1195	1980	770	1000	1000	1000	1000	B1	2"1/2	-	-
NX2-G06 /0122	2825	1195	1980	850	1000	1000	1000	1000	B1	2"1/2	-	-
NX2-G06 /0142	2825	1195	1980	920	1000	1000	1000	1000	B1	2"1/2	-	-
NX2-G06 /0162	3980	1195	1980	1130	1000	1000	1000	1000	B1	2"1/2	-	-
NX2-G06 /0182	3980	1195	1980	1170	1000	1000	1000	1000	B1	2"1/2	-	-
NX2-G06 /0202	3980	1195	1980	1180	1000	1000	1000	1000	B1	2"1/2	-	-
NX2-G06 /0222	3980	1195	1980	1220	1000	1000	1000	1000	B1	2"1/2	-	-
NX2-G06 /D /0042	1825	1195	1865	500	1000	1000	1000	1000	B1	1"1/2	B1	1"1/4
NX2-G06 /D /0052	1825	1195	1865	510	1000	1000	1000	1000	B1	1"1/2	B1	1"1/4
NX2-G06 /D /0062	1825	1195	1865	550	1000	1000	1000	1000	B1	1"1/2	B1	1"1/4
NX2-G06 /D /0072	2395	1195	1865	630	1000	1000	1000	1000	B1	2"	B1	1"1/4
NX2-G06 /D /0082	2395	1195	1865	630	1000	1000	1000	1000	B1	2"	B1	1"1/4
NX2-G06 /D /0092	2395	1195	1865	640	1000	1000	1000	1000	B1	2"	B1	1"1/4
NX2-G06 /D /0102	2825	1195	1980	770	1000	1000	1000	1000	B1	2"1/2	B1	1"1/4
NX2-G06 /D /0112	2825	1195	1980	770	1000	1000	1000	1000	B1	2"1/2	B1	1"1/4
NX2-G06 /D /0122	2825	1195	1980	850	1000	1000	1000	1000	B1	2"1/2	B1	1"1/4
NX2-G06 /D /0142	2825	1195	1980	920	1000	1000	1000	1000	B1	2"1/2	B1	1"1/4
NX2-G06 /D /0162	3980	1195	1980	1130	1000	1000	1000	1000	B1	2"1/2	B1	1"1/4
NX2-G06 /D /0182	3980	1195	1980	1170	1000	1000	1000	1000	B1	2"1/2	B1	1"1/4
NX2-G06 /D /0202	3980	1195	1980	1180	1000	1000	1000	1000	B1	2"1/2	B1	1"1/4
NX2-G06 /D /0222	3980	1195	1980	1220	1000	1000	1000	1000	B1	2"1/2	B1	1"1/4

DIMENSIONAL DRAWINGS

LEGEND OF PIPE CONNECTIONS

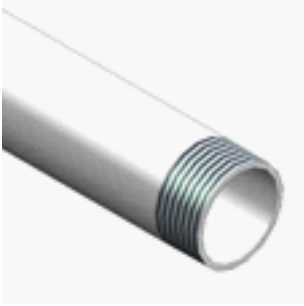

TYPE = B
Male threaded pipe

NOMINAL PIPE SIZE	PIPE OUTSIDE DIAMETER
ø inches	ø mm
¾	26,7
1	33,7
1 ¼	42,4
1 ½	48,3
2	60,3
2 ½	76,1
3	88,9
3 ½	101,6

NOMINAL PIPE SIZE	PIPE OUTSIDE DIAMETER
ø inches	ø mm
4	114,3
4 ½	127,0
5	139,7
6	168,3
8	219,1
10	273,0
12	323,9
14	355,6

UNI ISO 228/13

Pipe threads where pressure-tight joints are not made on the threads - Designation, dimensions and tolerances

Used terminology:

G: Pipe threads where pressure-tight joints are not made on the threads

A: Close tolerance class for external pipe threads where pressure-tight joints are not made on the threads

B: Wider tolerance class for external pipe threads where pressure-tight joints are not made on the threads

Internal threads: G letter followed by thread mark (only tolerance class)

External threads: G letter followed by thread mark and by A letter for A class external threads or by B letter for B class external threads.

UNI EN 10226-1

Pipe threads where pressure-tight joints are made on the threads - Designation, dimensions and tolerances

Used terminology:

Rp: Internal cylindrical threads where pressure-tight joints are made on the threads

Rc: Internal conical threads where pressure-tight joints are made on the threads

R: External conical threads where pressure-tight joints are made on the threads

Internal cylindrical threads: R letter followed by p letter

Internal conical threads: R letter followed by c letter

External conical threads: R letter

DESIGNATION	DESCRIPTION
UNI EN 10226-1 - Rp 1 1/2	Internal cylindrical threads where pressure-tight joints are made on the threads, defined by standard UNI ISO 7/1 Conventional ø 1 1/2"
UNI EN 10226-1 - Rp 2 1/2	Internal cylindrical threads where pressure-tight joints are made on the threads, defined by standard UNI ISO 7/1 Conventional ø 2 1/2"
UNI EN 10226-1 - Rp 3	Internal cylindrical threads where pressure-tight joints are made on the threads, defined by standard UNI ISO 7/1 Conventional ø 3"
UNI EN 10226-1 - R 3	External conical threads where pressure-tight joints are made on the threads, defined by standard UNI ISO 7/1 Conventional ø 3"
UNI ISO 228/1 - G 4 B	Internal cylindrical threads where pressure-tight joints are not made on the threads, defined by standard UNI ISO 228/1 Tolerance class B for external thread Conventional ø 4"
DN 80 PN 16	Flange Nominal Diameter: 80 mm Nominal Pressure: 16 bar

NOTE:

Conventional diameter value [in inches] identifies short thread designation, based upon the relative standard.

All relative values are defined by standards.

As example, here below some values:

	UNI EN 10226-1	UNI ISO 228/1
Conventional ø	1"	1"
Pitch	2.309 mm	2.309 mm
External ø	33.249 mm	33.249 mm
Core ø	30.291 mm	30.291 mm
Thread height	1.479 mm	1.479 mm

12.1 HYDRONIC GROUP

12.1 HYDRONIC MODULE

The units can be fitted with the hydronic module includes the main water circuit components, thus optimizing water circuit and electrical installation space, times and costs.

The built-in hydronic module is available as option with single or twin in-line pump, for achieving low head or high head, fixed or variable speed and with buffer tank.

The standard configuration of the units feature:

- terminals for external pumps control (relays + 0-10V signal)
- differential pressure switch (on heat exchanger)
- discharge valves on exchanger
- purge valve
- safety valve (10 bar)

For the hydronic modules with pumps, the factory-mounted components are:

- 1 or 2 pumps, 2 poles, low head or high head, fixed or variable speed
- differential pressure switch (on heat exchanger)
- discharge valves on exchanger
- purge valve
- safety valve (10 bar)

For the hydronic modules with pumps and buffer tank, the factory-mounted components are:

- 1 or 2 pumps, 2 poles, low head or high head, fixed or variable speed
- buffer tank covered by a 20 mm thick of insulation lining in closed-cell reticulated foam. Buffer tank capacity 90 l for sizes 0042, 0052, 0062. Buffer tank capacity 140 l for sizes 0072, 0082, 0092, 0102, 0112, 0122, 0142. Buffer tank capacity 250 l for sizes 0162, 0182, 0202, 0222.
- expansion tank (membrane made of EPDM) of 12 l of capacity (pre-charge: 2.5 bar) with buffer tank
- differential pressure switch (on heat exchanger)
- discharge and suction valves
- purge valve
- safety valve (8 bar)
- pressure gauge

Each of the components of the hydraulic group has been designed to optimise hydraulic and electrical installation space, time and costs.

The second pump operates in stand-by to the first.

The relative operating hours of the two pumps are balanced. In case the operating pump breaks down, the reserve pump is automatically enabled.

The electrical panel of the unit is protected with fuses and contactors with thermals cut-out.

Suction, volute and discharge of each pump and all the water pipes are covered with an insulation lining in closed-cell reticulated foam in PE, CFC and HCFC-free.

In units with opt. acoustical enclosure and NR kit, the hydronic group is protected by a self-ventilated enclosure, acoustically insulated by a 30 mm thick lining of polyester fibers (Fiberform).

Note: the use of ON/OFF pumps in units with opt. NR kit increases the sound power by 1 dB(A).

PUMP GROUP	Versions
EV - 2 PUMPS 2P LH (VAR SPEED)(4722)	X
EV - 2 PUMPS 2P HH (VAR SPEED)(4723)	X

Possible configurations

PUMP GROUP	Versions
EV - 1 PUMP 2P LH (FIX SPEED)(4706)	X
EV - 1 PUMP 2P HP (FIX SPEED)(4707)	X
EV - 2 PUMPS 2P LH (FIX SPEED)(4711)	X
EV - 2 PUMPS 2P HP (FIX SPEED)(4712)	X
EV - 1 PUMP 2P LH (VAR SPEED)(4717)	X
EV - 1 PUMP 2P HH (VAR SPEED)(4718)	X

SCHEMA IDRAULICO CON 1-2 POMPE
HYDRAULIC DIAGRAM WITH 1-2 PUMPS

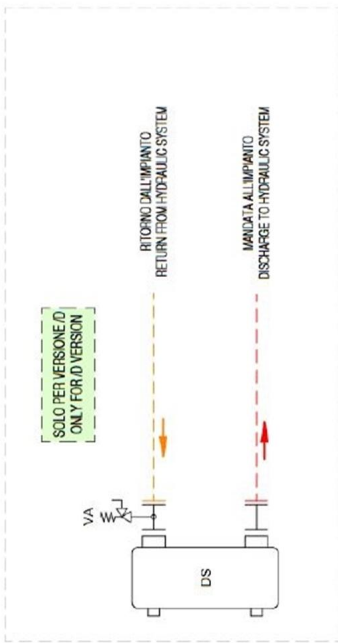
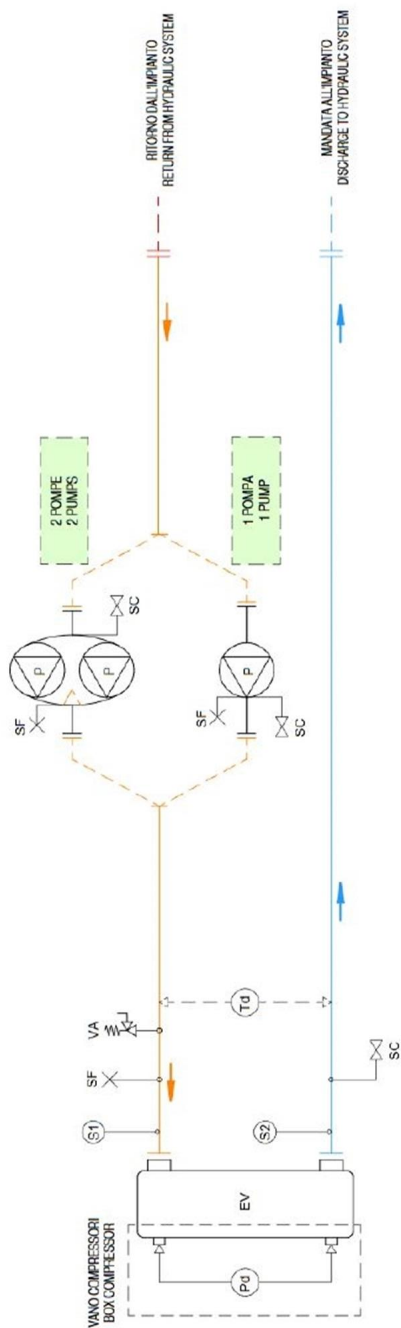

LEGENDA - LEGEND

DS	Desuriscaldatore (scambiatore a piastre - opzionale) Desuperheater (plate exchanger - optional)
EV	Evaporatore (scambiatore a piastre) Evaporator (plate exchanger)
P	Pompa di circolazione Circulation pump
Pd	Pressostato differenziale Differential pressure switch
SC	Valvola di scarico Drain valve
SF	Valvola di sfiato aria Air vent valve
S1/2	Sonda temperatura acqua Water temperature probe
Td	Trasduttore di pressione differenziale (solo con VPE) Differential pressure transducer (only with VPE)
VA	Valvola di sicurezza Safety valve

SCHEMA IDRAULICO CON 1-2 POMPE + ACCUMULO
HYDRAULIC DIAGRAM WITH 1-2 PUMPS + BUFFER TANK

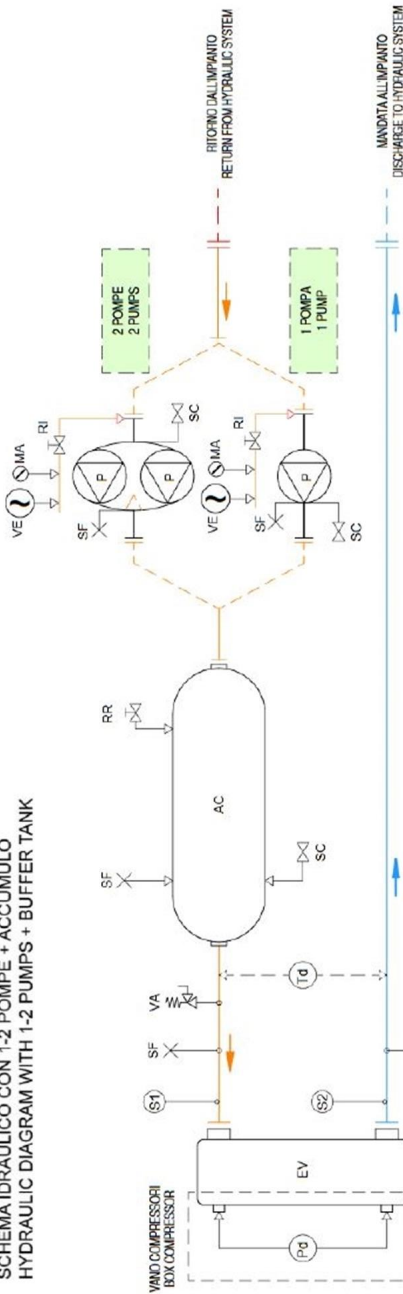

LEGENDA - LEGEND

AC	Accumulo Nucleus
DS	Disidratatore (a cambiabile o a rete - opzionale) Dehydrator (plate exchanger - optional)
EV	Evaporatore (a cambiabile o a rete) Evaporator (plate exchanger)
MA	Motore Motor
P	Pompa di circolazione Circulation pump
Pd	Pressostato differenziale Differential pressure switch
RI	Ritorno di refrigerante Refrigerant return
RR	Rifornimento Filling valve
SC	Valvola di scatto Drain valve
SF	Valvola di stato aria Air state valve
S1/S2	Sonda temperatura acqua Water temperature probe
Td	Trasduttore di pressione differenziale (solo con VPF) Differential pressure transducer (only with VPF)
VA	Valvola di sovrappressione Safety valve
VE	Impianto di refrigerazione Refrigeration system

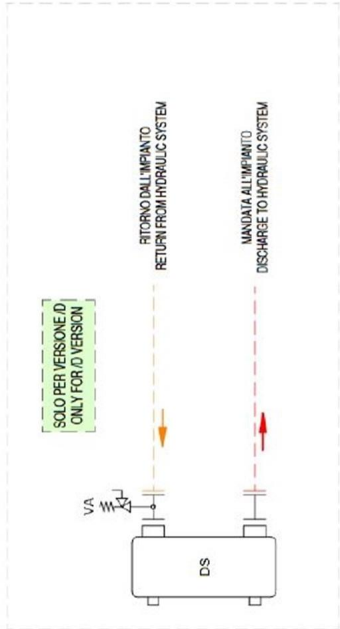

HYDRONIC GROUP

Hydronic kit positioning

	Version	EV - 1 PUMP 2P LH (FIX SPEED) (4706)				EV - 1 PUMP 2P HP (FIX SPEED) (4707)				EV - 2 PUMPS 2P LH (FIX SPEED) (4711)				EV - 2 PUMPS 2P HP (FIX SPEED) (4712)			
		extra L [mm]	extra W [mm]	extra H [mm]	extra WGT [kg]	extra L [mm]	extra W [mm]	extra H [mm]	extra WGT [kg]	extra L [mm]	extra W [mm]	extra H [mm]	extra WGT [kg]	extra L [mm]	extra W [mm]	extra H [mm]	extra WGT [kg]
0042		/	/	/	130	/	/	/	130	/	/	/	130	/	/	/	130
		/	/	/	130	/	/	/	130	/	/	/	130	/	/	/	130
		/	/	/	130	/	/	/	130	/	/	/	130	/	/	/	130
0052		/	/	/	130	/	/	/	130	/	/	/	130	/	/	/	130
		/	/	/	130	/	/	/	130	/	/	/	130	/	/	/	130
		/	/	/	130	/	/	/	130	/	/	/	130	/	/	/	130
0062		/	/	/	130	/	/	/	130	/	/	/	130	/	/	/	130
		/	/	/	130	/	/	/	130	/	/	/	130	/	/	/	130
		/	/	/	130	/	/	/	130	/	/	/	130	/	/	/	130
0072		/	/	/	140	/	/	/	140	/	/	/	140	/	/	/	140
		/	/	/	140	/	/	/	140	/	/	/	140	/	/	/	140
		/	/	/	140	/	/	/	140	/	/	/	140	/	/	/	140
0082		/	/	/	150	/	/	/	150	/	/	/	150	/	/	/	150
		/	/	/	150	/	/	/	150	/	/	/	150	/	/	/	150
		/	/	/	150	/	/	/	150	/	/	/	150	/	/	/	150
0092		/	/	/	150	/	/	/	150	/	/	/	150	/	/	/	150
		/	/	/	150	/	/	/	150	/	/	/	150	/	/	/	150
		/	/	/	150	/	/	/	150	/	/	/	150	/	/	/	150
0102		/	/	/	160	/	/	/	160	/	/	/	160	/	/	/	160
		/	/	/	160	/	/	/	160	/	/	/	160	/	/	/	160
		/	/	/	160	/	/	/	160	/	/	/	160	/	/	/	160
0112		/	/	/	160	/	/	/	160	/	/	/	160	/	/	/	160
		/	/	/	160	/	/	/	160	/	/	/	160	/	/	/	160
		/	/	/	160	/	/	/	160	/	/	/	160	/	/	/	160
0122		/	/	/	160	/	/	/	160	/	/	/	160	/	/	/	160
		/	/	/	160	/	/	/	160	/	/	/	160	/	/	/	160
		/	/	/	160	/	/	/	160	/	/	/	160	/	/	/	160
0142		/	/	/	160	/	/	/	160	/	/	/	160	/	/	/	160
		/	/	/	160	/	/	/	160	/	/	/	160	/	/	/	160
		/	/	/	160	/	/	/	160	/	/	/	160	/	/	/	160
0162		/	/	/	220	/	/	/	220	/	/	/	220	/	/	/	220
		/	/	/	220	/	/	/	220	/	/	/	220	/	/	/	220
		/	/	/	220	/	/	/	220	/	/	/	220	/	/	/	220
0182		/	/	/	210	/	/	/	210	/	/	/	210	/	/	/	210
		/	/	/	210	/	/	/	210	/	/	/	210	/	/	/	210
		/	/	/	210	/	/	/	210	/	/	/	210	/	/	/	210
0202		/	/	/	220	/	/	/	220	/	/	/	220	/	/	/	220
		/	/	/	220	/	/	/	220	/	/	/	220	/	/	/	220
		/	/	/	220	/	/	/	220	/	/	/	220	/	/	/	220
0222		/	/	/	210	/	/	/	210	/	/	/	210	/	/	/	210

- extra L Unit's extra length
- extra W Unit's extra operating width (NOT to be considered for transport)
- extra H Unit's extra height
- extra WGT Unit's extra weight (pumps and piping)
- EV - 1 PUMP 2P LH (FIX SPEED) EV - 1 PUMP 2P LH (FIX SPEED)
- EV - 1 PUMP 2P HP (FIX SPEED) EV - 1 PUMP 2P HP (FIX SPEED)
- EV - 2 PUMPS 2P LH (FIX SPEED) EV - 2 PUMPS 2P LH (FIX SPEED)
- EV - 2 PUMPS 2P HP (FIX SPEED) EV - 2 PUMPS 2P HP (FIX SPEED)
- Not available

HYDRONIC GROUP

Hydronic kit positioning

	Version	EV - 1 PUMP 2P LH (FIX SPEED) (4706)				EV - 1 PUMP 2P HP (FIX SPEED) (4707)				EV - 2 PUMPS 2P LH (FIX SPEED) (4711)				EV - 2 PUMPS 2P HP (FIX SPEED) (4712)			
		extra L [mm]	extra W [mm]	extra H [mm]	extra WGT [kg]	extra L [mm]	extra W [mm]	extra H [mm]	extra WGT [kg]	extra L [mm]	extra W [mm]	extra H [mm]	extra WGT [kg]	extra L [mm]	extra W [mm]	extra H [mm]	extra WGT [kg]
0222		/	/	/	210	/	/	/	210	/	/	/	210	/	/	/	210
		/	/	/	210	/	/	/	210	/	/	/	210	/	/	/	210

extra L	Unit's extra length
extra W	Unit's extra operating width (NOT to be considered for transport)
extra H	Unit's extra height
extra WGT	Unit's extra weight (pumps and piping)
EV - 1 PUMP 2P LH (FIX SPEED)	EV - 1 PUMP 2P LH (FIX SPEED)
EV - 1 PUMP 2P HP (FIX SPEED)	EV - 1 PUMP 2P HP (FIX SPEED)
EV - 2 PUMPS 2P LH (FIX SPEED)	EV - 2 PUMPS 2P LH (FIX SPEED)
EV - 2 PUMPS 2P HP (FIX SPEED)	EV - 2 PUMPS 2P HP (FIX SPEED)
-	Not available

HYDRONIC GROUP

Hydronic kit positioning

	Version	EV - 1 PUMP 2P LH (VAR SPEED) (4717)				EV - 1 PUMP 2P HH (VAR SPEED) (4718)				EV - 2 PUMPS 2P LH (VAR SPEED) (4722)				EV - 2 PUMPS 2P HH (VAR SPEED) (4723)			
		extra L [mm]	extra W [mm]	extra H [mm]	extra WGT [kg]	extra L [mm]	extra W [mm]	extra H [mm]	extra WGT [kg]	extra L [mm]	extra W [mm]	extra H [mm]	extra WGT [kg]	extra L [mm]	extra W [mm]	extra H [mm]	extra WGT [kg]
0042		/	/	/	130	/	/	/	130	/	/	/	130	/	/	/	130
		/	/	/	130	/	/	/	130	/	/	/	130	/	/	/	130
		/	/	/	130	/	/	/	130	/	/	/	130	/	/	/	130
0052		/	/	/	130	/	/	/	130	/	/	/	130	/	/	/	130
		/	/	/	130	/	/	/	130	/	/	/	130	/	/	/	130
		/	/	/	130	/	/	/	130	/	/	/	130	/	/	/	130
0062		/	/	/	130	/	/	/	130	/	/	/	130	/	/	/	130
		/	/	/	130	/	/	/	130	/	/	/	130	/	/	/	130
		/	/	/	130	/	/	/	130	/	/	/	130	/	/	/	130
0072		/	/	/	140	/	/	/	140	/	/	/	140	/	/	/	140
		/	/	/	140	/	/	/	140	/	/	/	140	/	/	/	140
		/	/	/	140	/	/	/	140	/	/	/	140	/	/	/	140
0082		/	/	/	150	/	/	/	150	/	/	/	150	/	/	/	150
		/	/	/	150	/	/	/	150	/	/	/	150	/	/	/	150
		/	/	/	150	/	/	/	150	/	/	/	150	/	/	/	150
0092		/	/	/	150	/	/	/	150	/	/	/	150	/	/	/	150
		/	/	/	150	/	/	/	150	/	/	/	150	/	/	/	150
		/	/	/	150	/	/	/	150	/	/	/	150	/	/	/	150
0102		/	/	/	160	/	/	/	160	/	/	/	160	/	/	/	160
		/	/	/	160	/	/	/	160	/	/	/	160	/	/	/	160
		/	/	/	160	/	/	/	160	/	/	/	160	/	/	/	160
0112		/	/	/	160	/	/	/	160	/	/	/	160	/	/	/	160
		/	/	/	160	/	/	/	160	/	/	/	160	/	/	/	160
		/	/	/	160	/	/	/	160	/	/	/	160	/	/	/	160
0122		/	/	/	160	/	/	/	160	/	/	/	160	/	/	/	160
		/	/	/	160	/	/	/	160	/	/	/	160	/	/	/	160
		/	/	/	160	/	/	/	160	/	/	/	160	/	/	/	160
0142		/	/	/	160	/	/	/	160	/	/	/	160	/	/	/	160
		/	/	/	160	/	/	/	160	/	/	/	160	/	/	/	160
		/	/	/	160	/	/	/	160	/	/	/	160	/	/	/	160
0162		/	/	/	220	/	/	/	220	/	/	/	220	/	/	/	220
		/	/	/	220	/	/	/	220	/	/	/	220	/	/	/	220
		/	/	/	220	/	/	/	220	/	/	/	220	/	/	/	220
0182		/	/	/	210	/	/	/	210	/	/	/	210	/	/	/	210
		/	/	/	210	/	/	/	210	/	/	/	210	/	/	/	210
		/	/	/	210	/	/	/	210	/	/	/	210	/	/	/	210
0202		/	/	/	220	/	/	/	220	/	/	/	220	/	/	/	220
		/	/	/	220	/	/	/	220	/	/	/	220	/	/	/	220
		/	/	/	220	/	/	/	220	/	/	/	220	/	/	/	220
0222		/	/	/	210	n.a.	n.a.	n.a.	n.a.	/	/	/	210	n.a.	n.a.	n.a.	n.a.

- extra L** Unit's extra length
- extra W** Unit's extra operating width (NOT to be considered for transport)
- extra H** Unit's extra height
- extra WGT** Unit's extra weight (pumps and piping)
- EV - 1 PUMP 2P LH (VAR SPEED)** EV - 1 PUMP 2P LH (VAR SPEED)
- EV - 1 PUMP 2P HH (VAR SPEED)** EV - 1 PUMP 2P HH (VAR SPEED)
- EV - 2 PUMPS 2P LH (VAR SPEED)** EV - 2 PUMPS 2P LH (VAR SPEED)
- EV - 2 PUMPS 2P HH (VAR SPEED)** EV - 2 PUMPS 2P HH (VAR SPEED)
- Not available

HYDRONIC GROUP

Hydronic kit positioning

	Version	EV - 1 PUMP 2P LH (VAR SPEED) (4717)				EV - 1 PUMP 2P HH (VAR SPEED) (4718)				EV - 2 PUMPS 2P LH (VAR SPEED) (4722)				EV - 2 PUMPS 2P HH (VAR SPEED) (4723)			
		extra L [mm]	extra W [mm]	extra H [mm]	extra WGT [kg]	extra L [mm]	extra W [mm]	extra H [mm]	extra WGT [kg]	extra L [mm]	extra W [mm]	extra H [mm]	extra WGT [kg]	extra L [mm]	extra W [mm]	extra H [mm]	extra WGT [kg]
0222		/	/	/	210	n.a.	n.a.	n.a.	n.a.	/	/	/	210	n.a.	n.a.	n.a.	n.a.
		/	/	/	210	n.a.	n.a.	n.a.	n.a.	/	/	/	210	n.a.	n.a.	n.a.	n.a.

extra L	Unit's extra length
extra W	Unit's extra operating width (NOT to be considered for transport)
extra H	Unit's extra height
extra WGT	Unit's extra weight (pumps and piping)
EV - 1 PUMP 2P LH (VAR SPEED)	EV - 1 PUMP 2P LH (VAR SPEED)
EV - 1 PUMP 2P HH (VAR SPEED)	EV - 1 PUMP 2P HH (VAR SPEED)
EV - 2 PUMPS 2P LH (VAR SPEED)	EV - 2 PUMPS 2P LH (VAR SPEED)
EV - 2 PUMPS 2P HH (VAR SPEED)	EV - 2 PUMPS 2P HH (VAR SPEED)
-	Not available

HYDRONIC GROUP

HEAT EXCHANGER USER SIDE - EV - 1 PUMP 2P HH (VAR SPEED)

SIZE		CH		PUMP					CH
		Pfgross	Qfgross	Rif.	Model	N.	F.L.A.	F.L.I.	HU
		[kW] (1)	[l/s] (1)			Pole	[A]	[kW]	[kPa]
0042		40,53	1,938	A1	TPE2 40-240-N	0	3	1,500	192
		41,19	1,970						190
		40,06	1,916						193
0052		48,58	2,323	A2					201
		49,35	2,360						200
		47,85	2,288						203
0062		54,16	2,590	A3					191
		54,80	2,621						190
		53,66	2,566						192
0072		60,98	2,916	B1					TPE2 50-240-N
		61,64	2,948		184				
		60,58	2,897		185				
0082		68,18	3,261	B2	184				
		69,02	3,301		182				
		67,63	3,234		184				
0092		79,82	3,817	B3	183				
		80,86	3,867		182				
		78,81	3,769		185				
0102		93,31	4,462	B4	195				
		94,36	4,512		194				
		92,45	4,421		196				
0112		103,8	4,965	B5	185				
		104,7	5,009		185				
		102,8	4,918		186				
0122		116,5	5,573	B6	184				
		118,1	5,650		182				
		115,2	5,508		185				
0142		129,6	6,198	B7	185				
		131,8	6,301		183				
		127,7	6,109		187				
0162		152,0	7,268	B8	175				
		154,0	7,363		173				
		150,4	7,191		176				
0182		174,2	8,331	B9	158				
		176,4	8,438		155				
		171,9	8,223		161				
0202		186,9	8,937	B10	151				
		189,8	9,077		147				
		184,2	8,809		155				

(1) Values refer to nominal conditions
 CH Cooling mode
 Pf Cooling capacity unit (Cooling mode)
 Pt Heating capacity unit (Heating mode)

Q Plant (side) exchanger water flow
 F.L.I. Pump power input
 F.L.A. Pump running current
 HU Pump residual pressure head (Units with hydronic group without mains filter)

HEAT EXCHANGER USER SIDE - EV - 1 PUMP 2P HH (VAR SPEED)

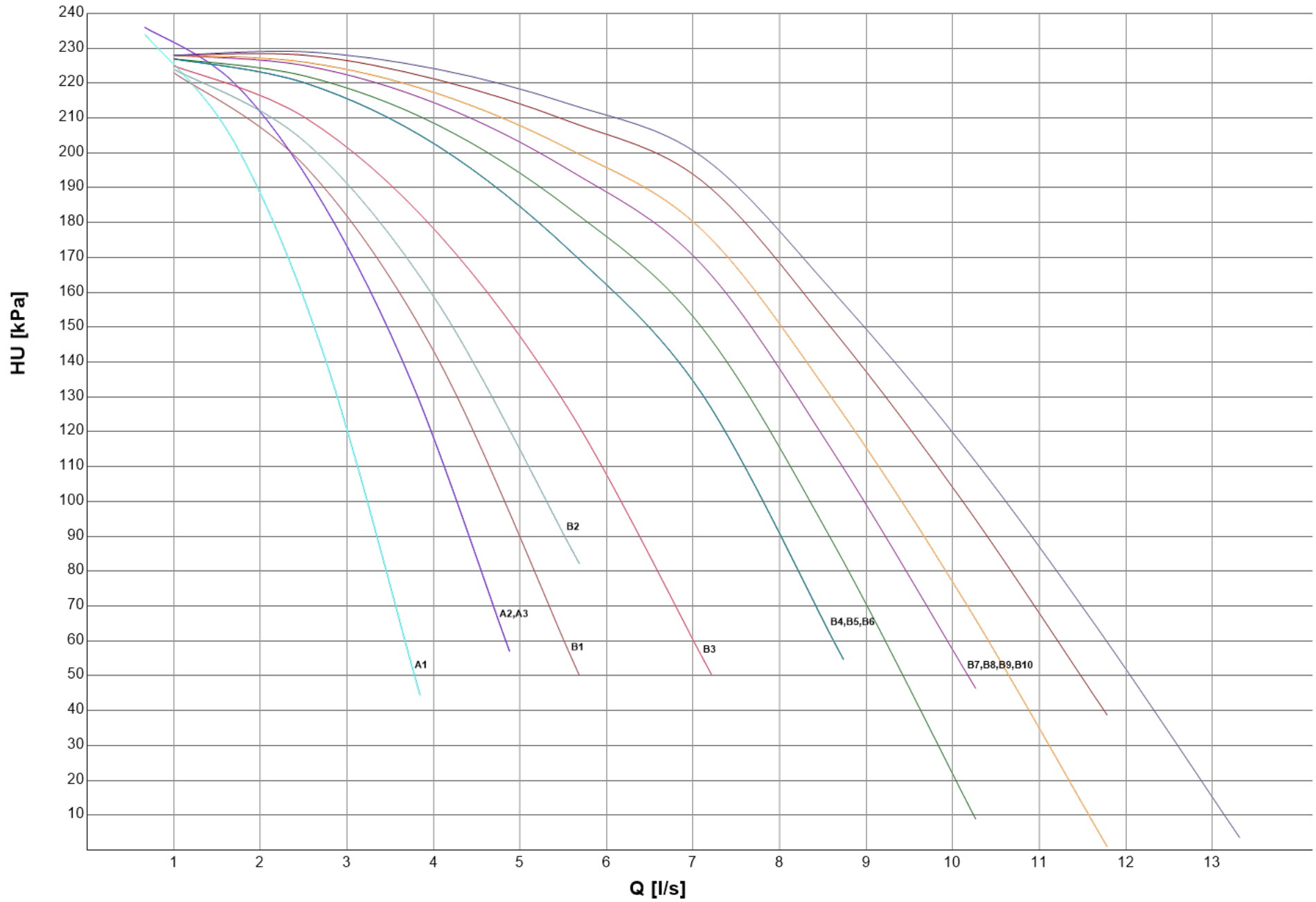

HYDRONIC GROUP

HEAT EXCHANGER USER SIDE - EV - 1 PUMP 2P HP (FIX SPEED)

SIZE		CH		PUMP					CH
		Pfgross	Qfgross	Rif.	Model	N.	F.L.A.	F.L.I.	HU
		[kW] (1)	[l/s] (1)			Pole	[A]	[kW]	[kPa]
0042		40,53	1,938	A1					217
		41,19	1,970						216
		40,06	1,916						219
0052		48,58	2,323	A2	LNEE 32-160/22	2	5	2,200	227
		49,35	2,360						225
		47,85	2,288						228
0062		54,16	2,590	A3					216
		54,80	2,621						215
		53,66	2,566						217
0072		60,98	2,916	B1					249
		61,64	2,948						248
		60,58	2,897						250
0082		68,18	3,261	B2	LNEE 40-160/30/2	2	6	3,000	246
		69,02	3,301						245
		67,63	3,234						247
0092		79,82	3,817	B3					243
		80,86	3,867						241
		78,81	3,769						245
0102		93,31	4,462	C1					231
		94,36	4,512						230
		92,45	4,421						232
0112		103,8	4,965	C2					218
		104,7	5,009						217
		102,8	4,918						219
0122		116,5	5,573	C3	LNEE 40-125/30	2	6	3,000	211
		118,1	5,650						209
		115,2	5,508						213
0142		129,6	6,198	C4					205
		131,8	6,301						201
		127,7	6,109						207
0162		152,0	7,268	D1					265
		154,0	7,363						263
		150,4	7,191						266
0182		174,2	8,331	D2					262
		176,4	8,438						260
		171,9	8,223						264
0202		186,9	8,937	D3	LNEE 50-160/55/2	2	11	5,500	263
		189,8	9,077						261
		184,2	8,809						265
0222		208,7	9,979	D4					244
		211,8	10,13						241
		206,4	9,871						246

(1) Values refer to nominal conditions
 CH Cooling mode
 Pf Cooling capacity unit (Cooling mode)
 Pt Heating capacity unit (Heating mode)

Q Plant (side) exchanger water flow
 F.L.I. Pump power input
 F.L.A. Pump running current
 HU Pump residual pressure head (Units with hydronic group without mains filter)

HEAT EXCHANGER USER SIDE - EV - 1 PUMP 2P HP (FIX SPEED)

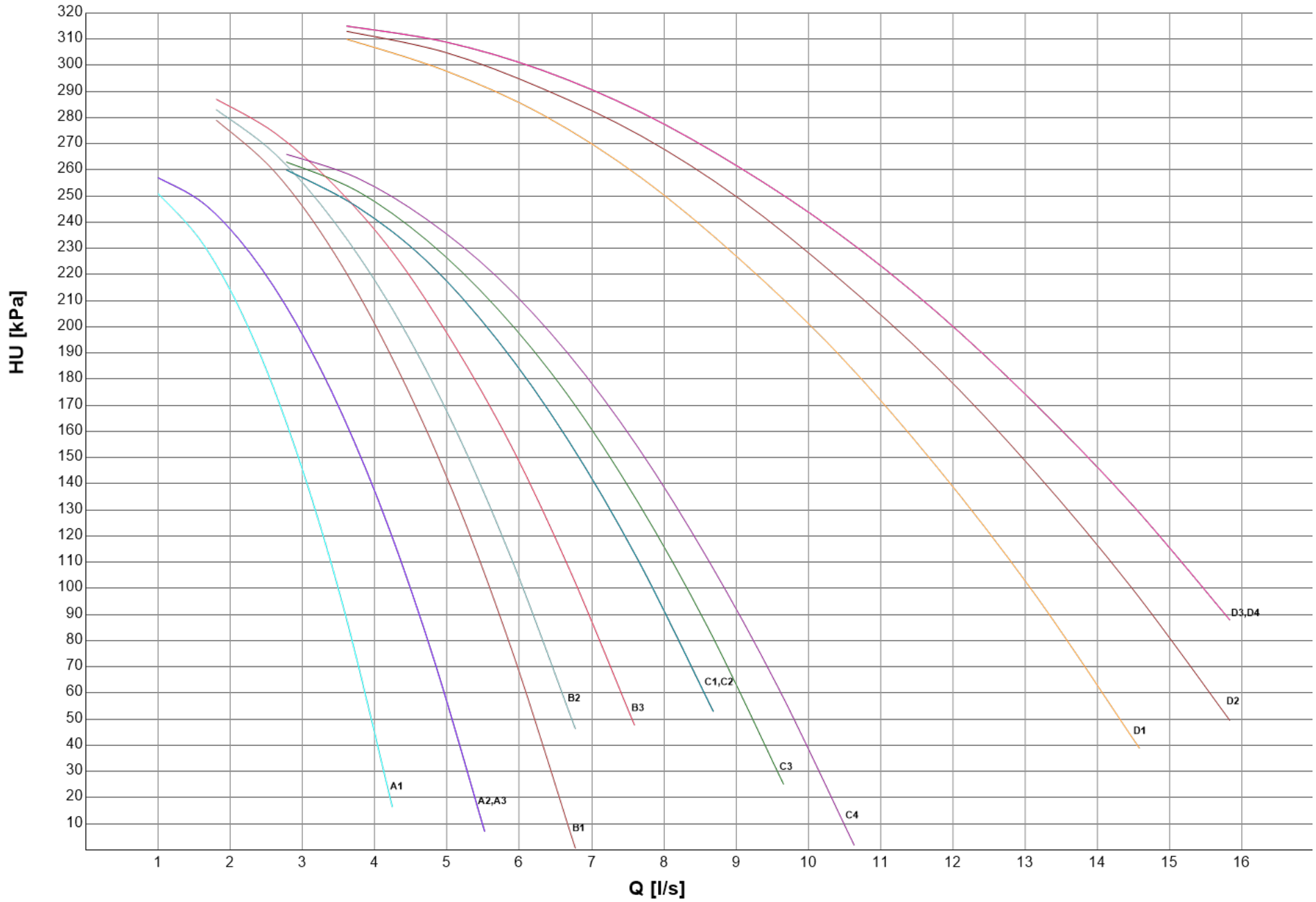

HYDRONIC GROUP

HEAT EXCHANGER USER SIDE - EV - 1 PUMP 2P LH (FIX SPEED)

SIZE	CH		PUMP				CH	
	Pfgross	Qfgross	Rif.	Model	N.	F.L.A.	F.L.I.	HU
	[kW] (1)	[l/s] (1)			Pole	[A]	[kW]	
0042	40,53	1,938	A1	LNEE 32-160/11	2	2	1,100	117
	41,19	1,970						116
	40,06	1,916						119
0052	48,58	2,323	A2	LNEE 32-160/11	2	2	1,100	125
	49,35	2,360						124
	47,85	2,288						127
0062	54,16	2,590	A3	LNEE 32-160/11	2	2	1,100	114
	54,80	2,621						112
	53,66	2,566						115
0072	60,98	2,916	B1	LNEE 40-125/15/2	2	3	1,500	126
	61,64	2,948						125
	60,58	2,897						127
0082	68,18	3,261	B2	LNEE 40-125/15/2	2	3	1,500	123
	69,02	3,301						122
	67,63	3,234						124
0092	79,82	3,817	B3	LNEE 40-125/15/2	2	3	1,500	119
	80,86	3,867						117
	78,81	3,769						120
0102	93,31	4,462	C1	LNEE 50-125/22/2	2	5	2,200	135
	94,36	4,512						134
	92,45	4,421						135
0112	103,8	4,965	C2	LNEE 50-125/22/2	2	5	2,200	124
	104,7	5,009						123
	102,8	4,918						125
0122	116,5	5,573	C3	LNEE 50-125/22/2	2	5	2,200	120
	118,1	5,650						118
	115,2	5,508						122
0142	129,6	6,198	C4	LNEE 50-125/22/2	2	5	2,200	119
	131,8	6,301						117
	127,7	6,109						121
0162	152,0	7,268	D1	LNEE 50-125/30/2	2	6	3,000	146
	154,0	7,363						144
	150,4	7,191						147
0182	174,2	8,331	D2	LNEE 50-125/30/2	2	6	3,000	140
	176,4	8,438						137
	171,9	8,223						142
0202	186,9	8,937	D3	LNEE 50-125/30/2	2	6	3,000	139
	189,8	9,077						136
	184,2	8,809						141
0222	208,7	9,979	D4	LNEE 50-125/30/2	2	6	3,000	116
	211,8	10,13						112
	206,4	9,871						118

(1) Values refer to nominal conditions
 CH Cooling mode
 Pf Cooling capacity unit (Cooling mode)
 Pt Heating capacity unit (Heating mode)

Q Plant (side) exchanger water flow
 F.L.I. Pump power input
 F.L.A. Pump running current
 HU Pump residual pressure head (Units with hydronic group without mains filter)

HEAT EXCHANGER USER SIDE - EV - 1 PUMP 2P LH (FIX SPEED)

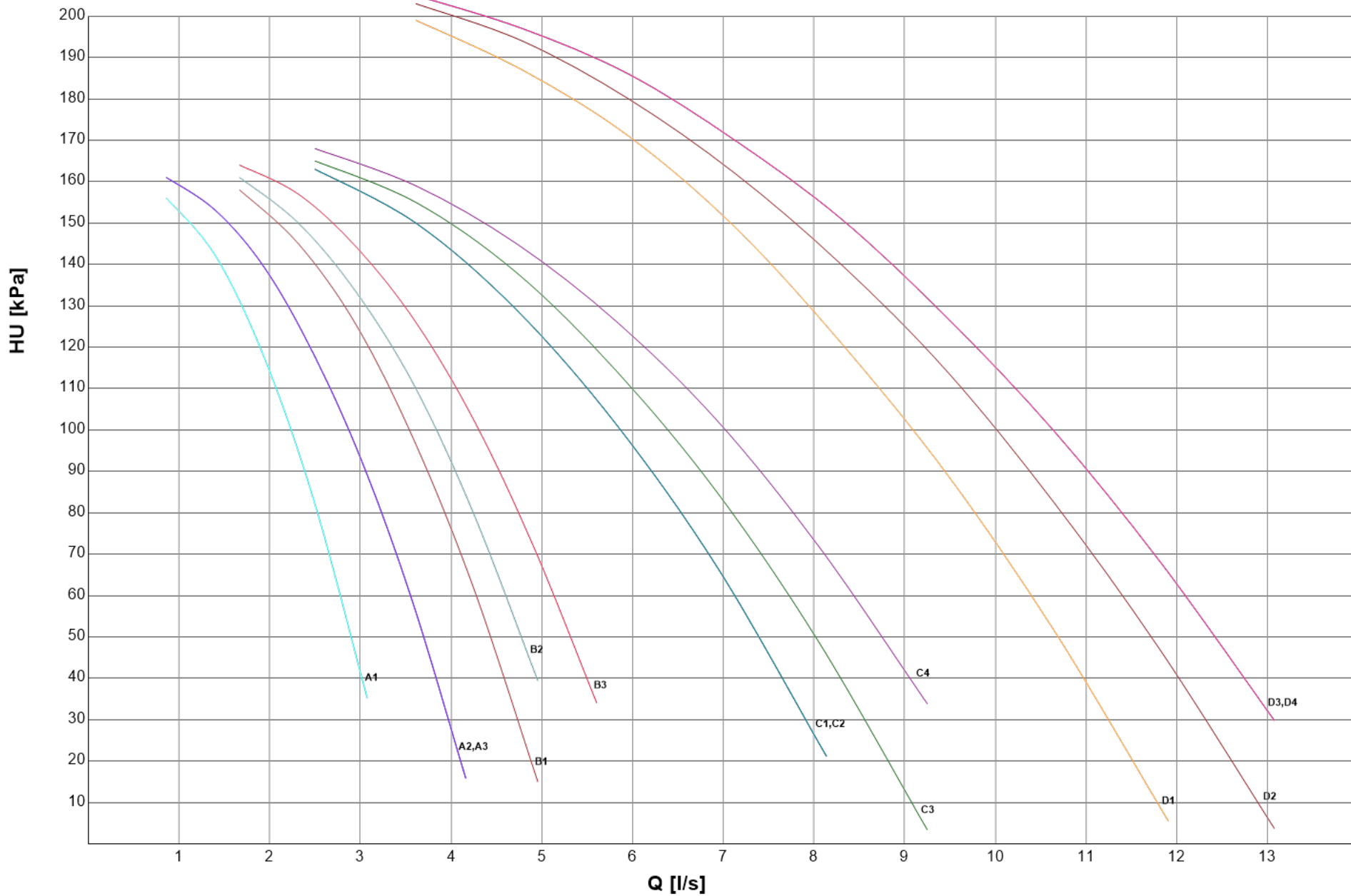

HYDRONIC GROUP

HEAT EXCHANGER USER SIDE - EV - 1 PUMP 2P LH (VAR SPEED)

SIZE	CH		PUMP				CH					
	Pfgross	Qfgross	Rif.	Model	N.	F.L.A.	F.L.I.	HU				
	[kW] (1)	[l/s] (1)			Pole	[A]	[kW]		[kPa]			
0042	40,53	1,938	A1	TPE2 40-180-N	2	2	0,750	136				
	41,19	1,970						134				
	40,06	1,916						137				
0052	48,58	2,323	A2					134				
	49,35	2,360						132				
	47,85	2,288						135				
0062	54,16	2,590	A3					119				
	54,80	2,621						117				
	53,66	2,566						120				
0072	60,98	2,916	B1					TPE2 50-180-N	2	2	1,100	126
	61,64	2,948										125
	60,58	2,897										127
0082	68,18	3,261	B2	125								
	69,02	3,301		124								
	67,63	3,234		126								
0092	79,82	3,817	B3	118								
	80,86	3,867		116								
	78,81	3,769		120								
0102	93,31	4,462	B4	121								
	94,36	4,512		119								
	92,45	4,421		122								
0112	103,8	4,965	B5	105								
	104,7	5,009		104								
	102,8	4,918		107								
0122	116,5	5,573	B6	96,1								
	118,1	5,650		93,7								
	115,2	5,508		98,1								
0142	129,6	6,198	B7	89,6								
	131,8	6,301		86,5								
	127,7	6,109		92,1								
0162	152,0	7,268	C1	TPE2 65-200-N	2	4	2,200					123
	154,0	7,363										121
	150,4	7,191										124
0182	174,2	8,331	C2					117				
	176,4	8,438						115				
	171,9	8,223						119				
0202	186,9	8,937	C3					116				
	189,8	9,077						113				
	184,2	8,809						119				
0222	208,7	9,979	C4					94,0				
	211,8	10,13						90,6				
	206,4	9,871						96,4				

(1) Values refer to nominal conditions
 CH Cooling mode
 Pf Cooling capacity unit (Cooling mode)
 Pt Heating capacity unit (Heating mode)

Q Plant (side) exchanger water flow
 F.L.I. Pump power input
 F.L.A. Pump running current
 HU Pump residual pressure head (Units with hydronic group without mains filter)

HEAT EXCHANGER USER SIDE - EV - 1 PUMP 2P LH (VAR SPEED)

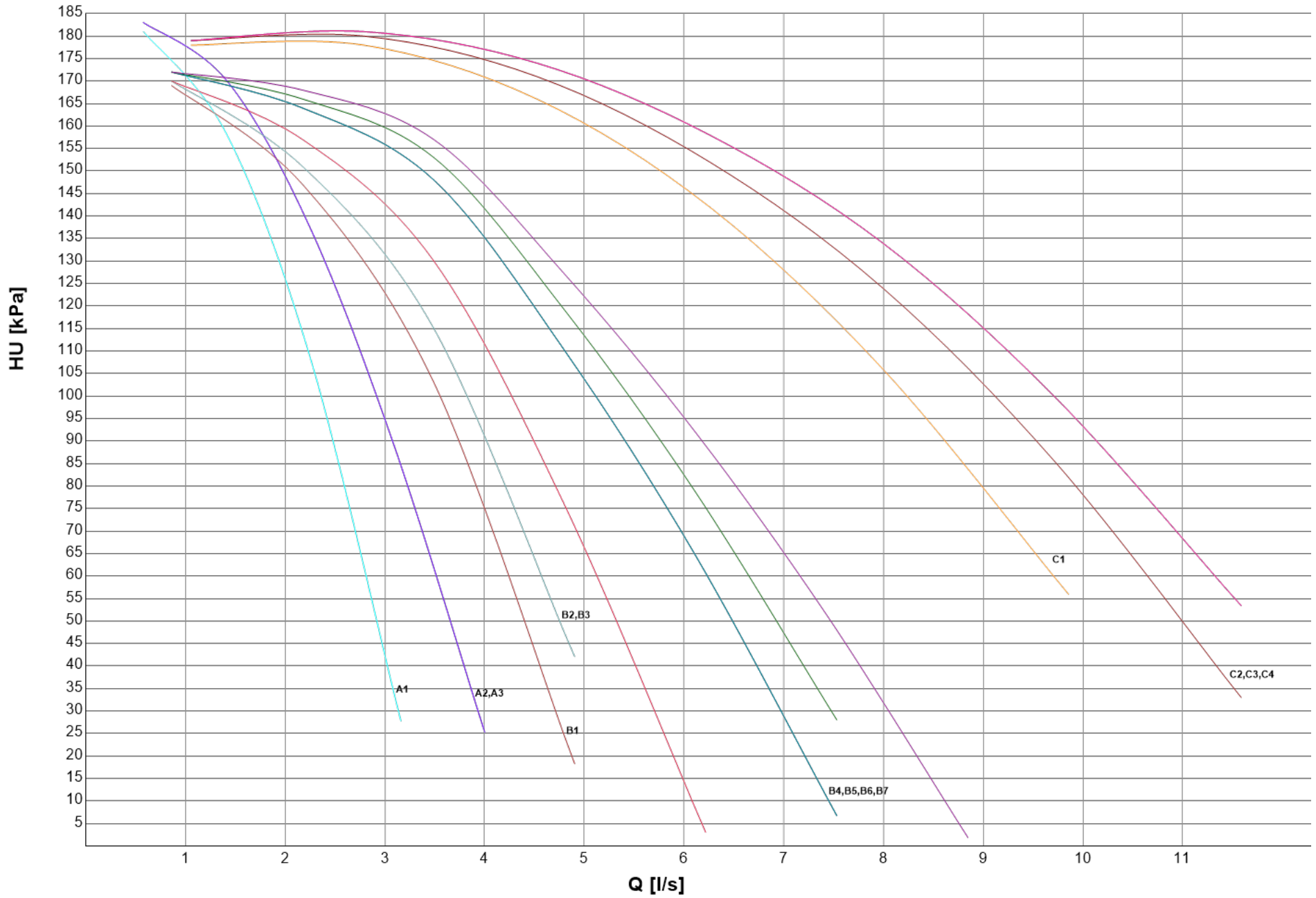

HYDRONIC GROUP

HEAT EXCHANGER USER SIDE - EV - 2 PUMPS 2P HH (VAR SPEED)

SIZE	CH		PUMP				CH	
	Pfgross	Qfgross	Rif.	Model	N.	F.L.A.	F.L.I.	HU
	[kW] (1)	[l/s] (1)			Pole	[A]	[kW]	
0042	40,53	1,938	A1	TPE2 D 40-240-N	0	3	1,500	193
	41,19	1,970						191
	40,06	1,916						194
0052	48,58	2,323	A2					202
	49,35	2,360						201
	47,85	2,288						203
0062	54,16	2,590	A3					192
	54,80	2,621						191
	53,66	2,566						193
0072	60,98	2,916	B1					187
	61,64	2,948		187				
	60,58	2,897		188				
0082	68,18	3,261	B2	186				
	69,02	3,301		185				
	67,63	3,234		187				
0092	79,82	3,817	B3	187				
	80,86	3,867		185				
	78,81	3,769		188				
0102	93,31	4,462	B4	199				
	94,36	4,512		198				
	92,45	4,421		199				
0112	103,8	4,965	B5	190				
	104,7	5,009		189				
	102,8	4,918		191				
0122	116,5	5,573	B6	189				
	118,1	5,650		188				
	115,2	5,508		191				
0142	129,6	6,198	B7	192				
	131,8	6,301		190				
	127,7	6,109		193				
0162	152,0	7,268	B8	169				
	154,0	7,363		166				
	150,4	7,191		172				
0182	174,2	8,331	B9	150				
	176,4	8,438		146				
	171,9	8,223		153				
0202	186,9	8,937	B10	141				
	189,8	9,077		137				
	184,2	8,809		146				

(1) Values refer to nominal conditions
 CH Cooling mode
 Pf Cooling capacity unit (Cooling mode)
 Pt Heating capacity unit (Heating mode)

Q Plant (side) exchanger water flow
 F.L.I. Pump power input
 F.L.A. Pump running current
 HU Pump residual pressure head (Units with hydronic group without mains filter)

HEAT EXCHANGER USER SIDE - EV - 2 PUMPS 2P HH (VAR SPEED)

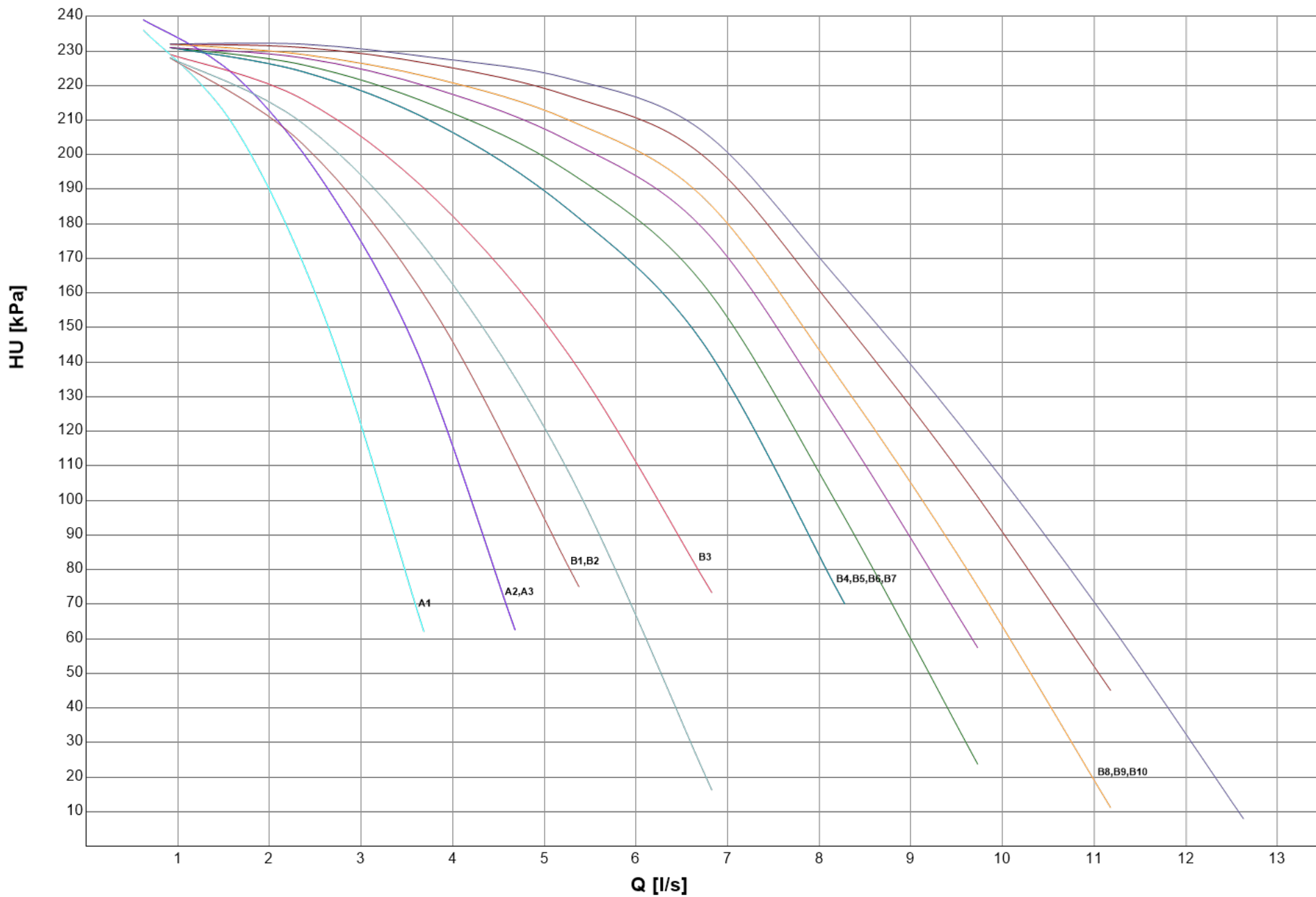

HYDRONIC GROUP

HEAT EXCHANGER USER SIDE - EV - 2 PUMPS 2P HP (FIX SPEED)

SIZE	CH		PUMP					CH				
	Pfgross	Qfgross	Rif.	Model	N.	F.L.A.	F.L.I.	HU				
	[kW] (1)	[l/s] (1)			Pole	[A]	[kW]	[kPa]				
0042	40,53	1,938	A1	LNTE 32-160/22/2	2	5	2,200	218				
	41,19	1,970						216				
	40,06	1,916						219				
0052	48,58	2,323	A2					225				
	49,35	2,360						223				
	47,85	2,288						226				
0062	54,16	2,590	A3					213				
	54,80	2,621						211				
	53,66	2,566						214				
0072	60,98	2,916	B1					LNTE 40-160/30/2	2	6	3,000	244
	61,64	2,948										243
	60,58	2,897										245
0082	68,18	3,261	B2	241								
	69,02	3,301		240								
	67,63	3,234		242								
0092	79,82	3,817	B3	238								
	80,86	3,867		236								
	78,81	3,769		239								
0102	93,31	4,462	C1	LNTE 40-125/30	2	6	3,000					225
	94,36	4,512										224
	92,45	4,421										226
0112	103,8	4,965	C2					210				
	104,7	5,009						209				
	102,8	4,918						212				
0122	116,5	5,573	C3					201				
	118,1	5,650						199				
	115,2	5,508						203				
0142	129,6	6,198	C4					194				
	131,8	6,301						190				
	127,7	6,109						196				
0162	152,0	7,268	D1	LNTE 50-160/55/2	2	11	5,500	268				
	154,0	7,363						266				
	150,4	7,191						270				
0182	174,2	8,331	D2					264				
	176,4	8,438						262				
	171,9	8,223						266				
0202	186,9	8,937	D3					264				
	189,8	9,077						261				
	184,2	8,809						266				
0222	208,7	9,979	D4					242				
	211,8	10,13						239				
	206,4	9,871						245				

(1) Values refer to nominal conditions
 CH Cooling mode
 Pf Cooling capacity unit (Cooling mode)
 Pt Heating capacity unit (Heating mode)

Q Plant (side) exchanger water flow
 F.L.I. Pump power input
 F.L.A. Pump running current
 HU Pump residual pressure head (Units with hydronic group without mains filter)

HEAT EXCHANGER USER SIDE - EV - 2 PUMPS 2P HP (FIX SPEED)

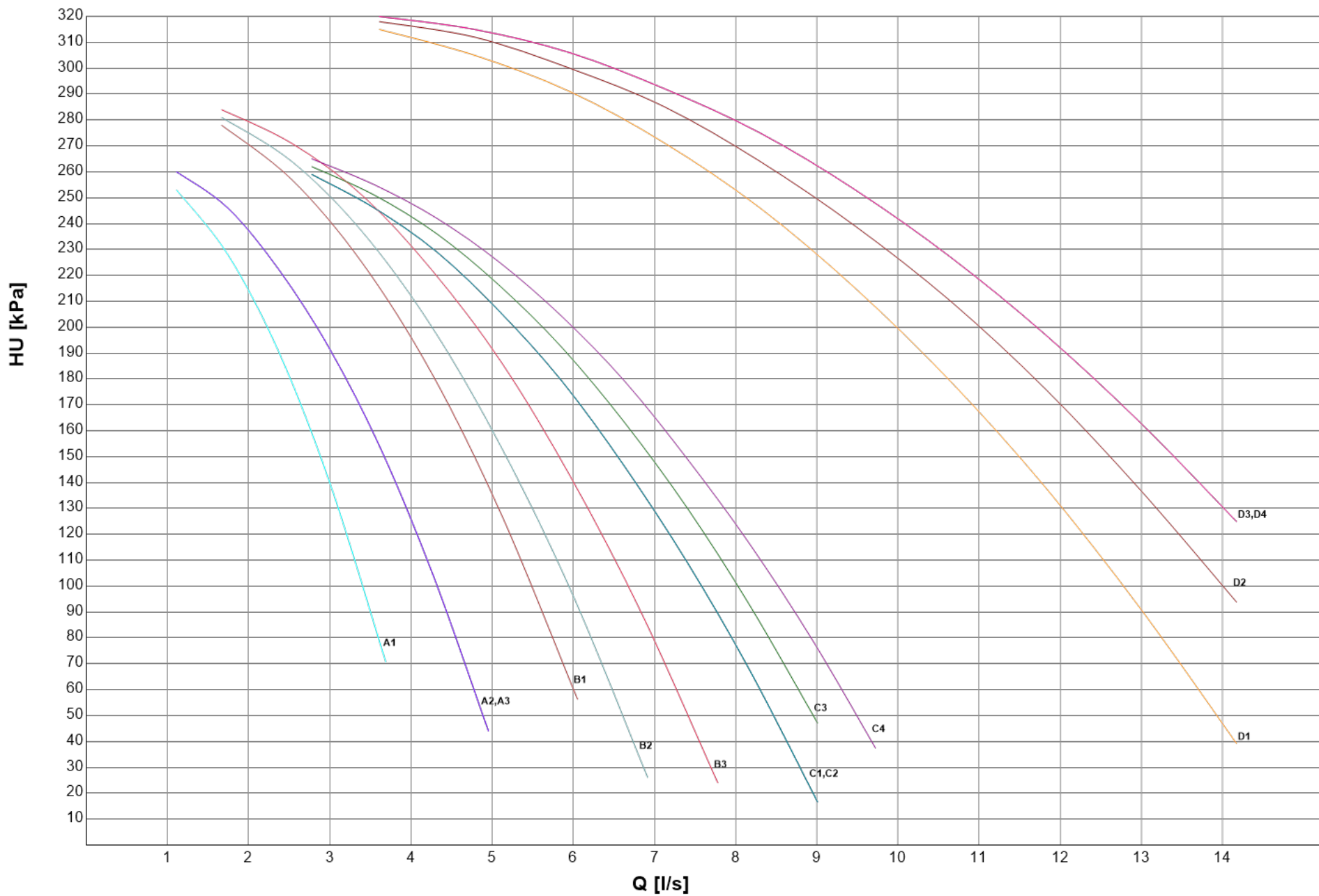

HYDRONIC GROUP

HEAT EXCHANGER USER SIDE - EV - 2 PUMPS 2P LH (FIX SPEED)

SIZE	CH		PUMP					CH
	Pfgross	Qfgross	Rif.	Model	N.	F.L.A.	F.L.I.	HU
	[kW] (1)	[l/s] (1)			Pole	[A]	[kW]	[kPa]
0042	40,53	1,938	A1	LNTE 32-160/11/2	2	2	1,100	116
	41,19	1,970						114
	40,06	1,916						117
0052	48,58	2,323	A2					123
	49,35	2,360						121
	47,85	2,288						124
0062	54,16	2,590	A3					110
	54,80	2,621						109
	53,66	2,566						111
0072	60,98	2,916	B1					125
	61,64	2,948						124
	60,58	2,897						126
0082	68,18	3,261	B2	120				
	69,02	3,301		118				
	67,63	3,234		121				
0092	79,82	3,817	B3	111				
	80,86	3,867		109				
	78,81	3,769		113				
0102	93,31	4,462	C1	128				
	94,36	4,512		127				
	92,45	4,421		129				
0112	103,8	4,965	C2	116				
	104,7	5,009		115				
	102,8	4,918		117				
0122	116,5	5,573	C3	111				
	118,1	5,650		110				
	115,2	5,508		113				
0142	129,6	6,198	C4	109				
	131,8	6,301		107				
	127,7	6,109		111				
0162	152,0	7,268	D1	134				
	154,0	7,363		132				
	150,4	7,191		136				
0182	174,2	8,331	D2	126				
	176,4	8,438		124				
	171,9	8,223		129				
0202	186,9	8,937	D3	125				
	189,8	9,077		121				
	184,2	8,809		127				
0222	208,7	9,979	D4	100				
	211,8	10,13		96,8				
	206,4	9,871		103				

(1) Values refer to nominal conditions
 CH Cooling mode
 Pf Cooling capacity unit (Cooling mode)
 Pt Heating capacity unit (Heating mode)

Q Plant (side) exchanger water flow
 F.L.I. Pump power input
 F.L.A. Pump running current
 HU Pump residual pressure head (Units with hydronic group without mains filter)

HEAT EXCHANGER USER SIDE - EV - 2 PUMPS 2P LH (FIX SPEED)

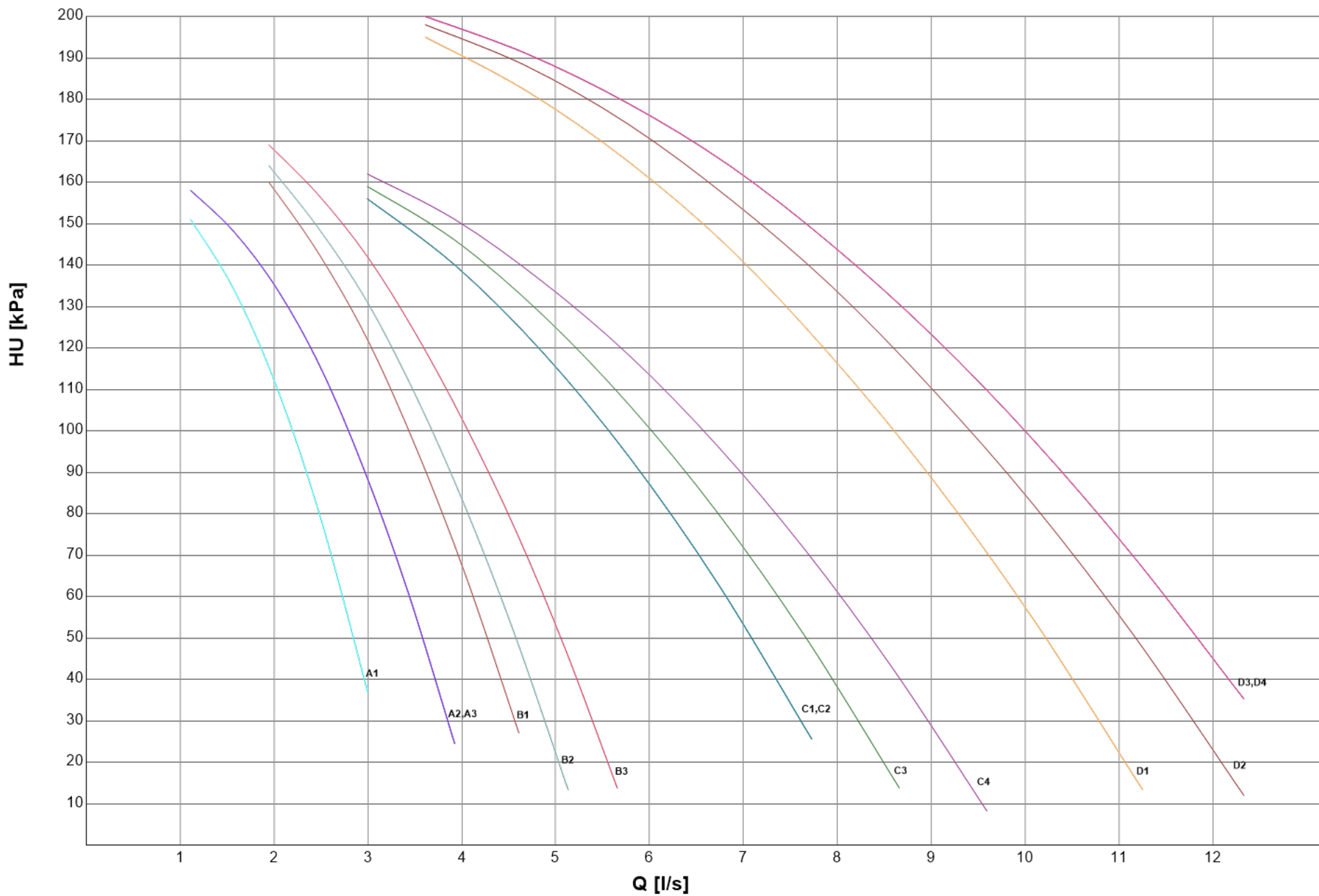

HYDRONIC GROUP

HEAT EXCHANGER USER SIDE - EV - 2 PUMPS 2P LH (VAR SPEED)

SIZE	CH		PUMP					CH				
	Pfgross	Qfgross	Rif.	Model	N.	F.L.A.	F.L.I.	HU				
	[kW] (1)	[l/s] (1)			Pole	[A]	[kW]	[kPa]				
0042	40,53	1,938	A1	TPE2 D 40-180-N	2	2	0,750	137				
	41,19	1,970						136				
	40,06	1,916						138				
0052	48,58	2,323	A2					135				
	49,35	2,360						133				
	47,85	2,288						137				
0062	54,16	2,590	A3					119				
	54,80	2,621						117				
	53,66	2,566						121				
0072	60,98	2,916	B1					TPE2 D 50-180-N	2	2	1,100	128
	61,64	2,948										127
	60,58	2,897										129
0082	68,18	3,261	B2									127
	69,02	3,301										126
	67,63	3,234										128
0092	79,82	3,817	B3	118								
	80,86	3,867		116								
	78,81	3,769		120								
0102	93,31	4,462	B4	120								
	94,36	4,512		118								
	92,45	4,421		121								
0112	103,8	4,965	B5	103								
	104,7	5,009		102								
	102,8	4,918		105								
0122	116,5	5,573	B6	93,1								
	118,1	5,650		90,5								
	115,2	5,508		95,2								
0142	129,6	6,198	B7	85,1								
	131,8	6,301		81,8								
	127,7	6,109		87,9								
0162	152,0	7,268	C1	TPE2 D 65-200	2	4	2,200	126				
	154,0	7,363						124				
	150,4	7,191						127				
0182	174,2	8,331	C2					121				
	176,4	8,438						118				
	171,9	8,223						123				
0202	186,9	8,937	C3					120				
	189,8	9,077						117				
	184,2	8,809						123				
0222	208,7	9,979	C4					98,5				
	211,8	10,13						95,1				
	206,4	9,871						101				

(1) Values refer to nominal conditions
 CH Cooling mode
 Pf Cooling capacity unit (Cooling mode)
 Pt Heating capacity unit (Heating mode)

Q Plant (side) exchanger water flow
 F.L.I. Pump power input
 F.L.A. Pump running current
 HU Pump residual pressure head (Units with hydronic group without mains filter)

HEAT EXCHANGER USER SIDE - EV - 2 PUMPS 2P LH (VAR SPEED)

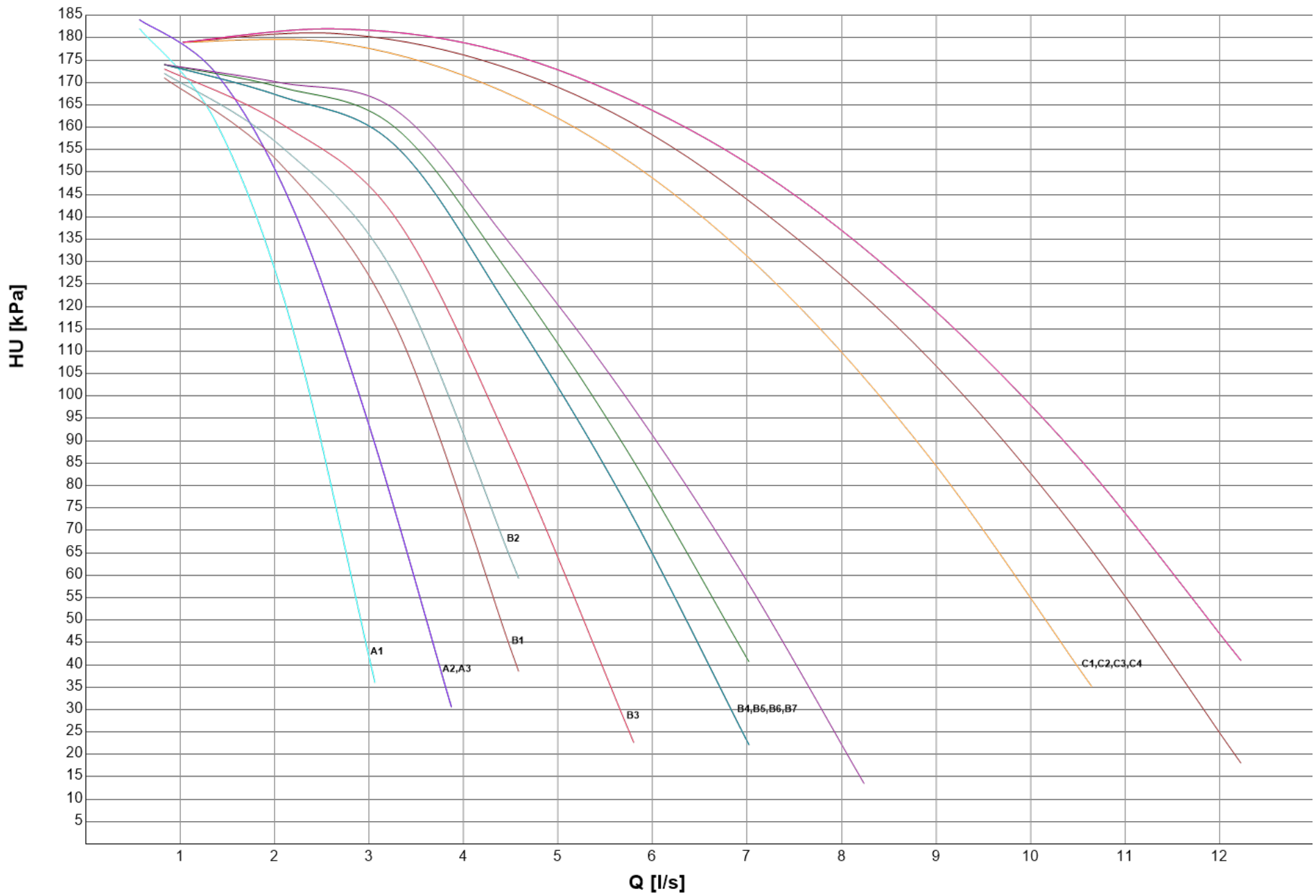

VARIABLE FLOW CONTROL

Pump energy consumption significantly impacts plant running costs, but it can be considerably reduced thanks to the use of variable speed pumps (inverter driven pumps), capable of adjusting the water flow rate according to the actual plant thermal load.

Mitsubishi Electric Hydronics & Cooling Systems has developed the VPF control series (Variable Primary Flow), that provides different water flow regulation logics specifically devoted to various hydraulic plant solutions: only a primary circuit, primary and secondary circuits, single

unit or multi-unit systems controlled with external controller (Manager 3000, ClimaPRO) or with 1541, 1542 Multi Manager options. The VPF systems adjust the pump speeds on the basis of the plant's thermal load and optimize the unit's thermoregulation algorithm for variable flow operation, in a dynamic and simultaneous way. This ensures the highest energy savings, stable operation, and complete reliability.

VPF SYSTEM (delta P control) For plants with only a primary circuit

VPF - Plant and unit requirements

The VPF logic provides the variable flow control for the plant's primary circuit.

- Type of plant: primary circuit only, that feeds hydronic terminals fitted with a 2-way regulating valve
- Hydronic module: modulating regulation devices (0-10V signal) or variable speed pumps
- Unit thermoregulation: control of the leaving water temperature
- Monitored parameter: delta P on relevant users' hydronic terminal

Plant diagram for single unit system

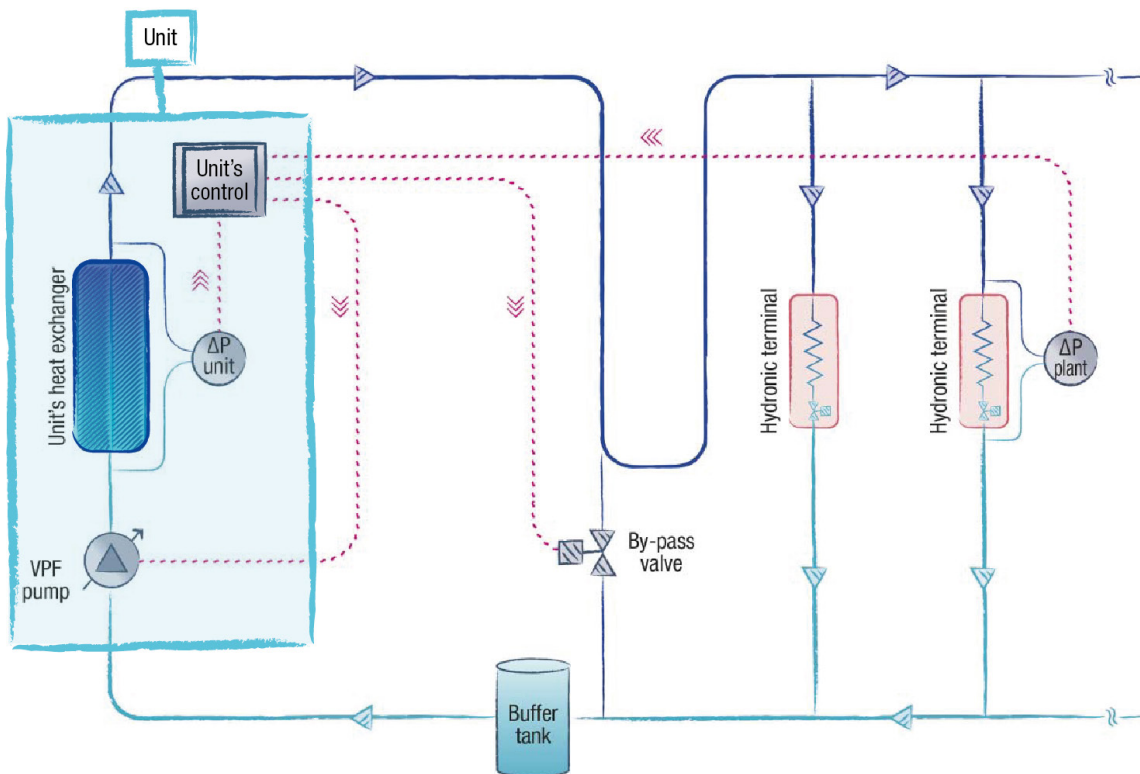

Plant diagram for multi-unit with external control system (Manager3000 or ClimaPRO)

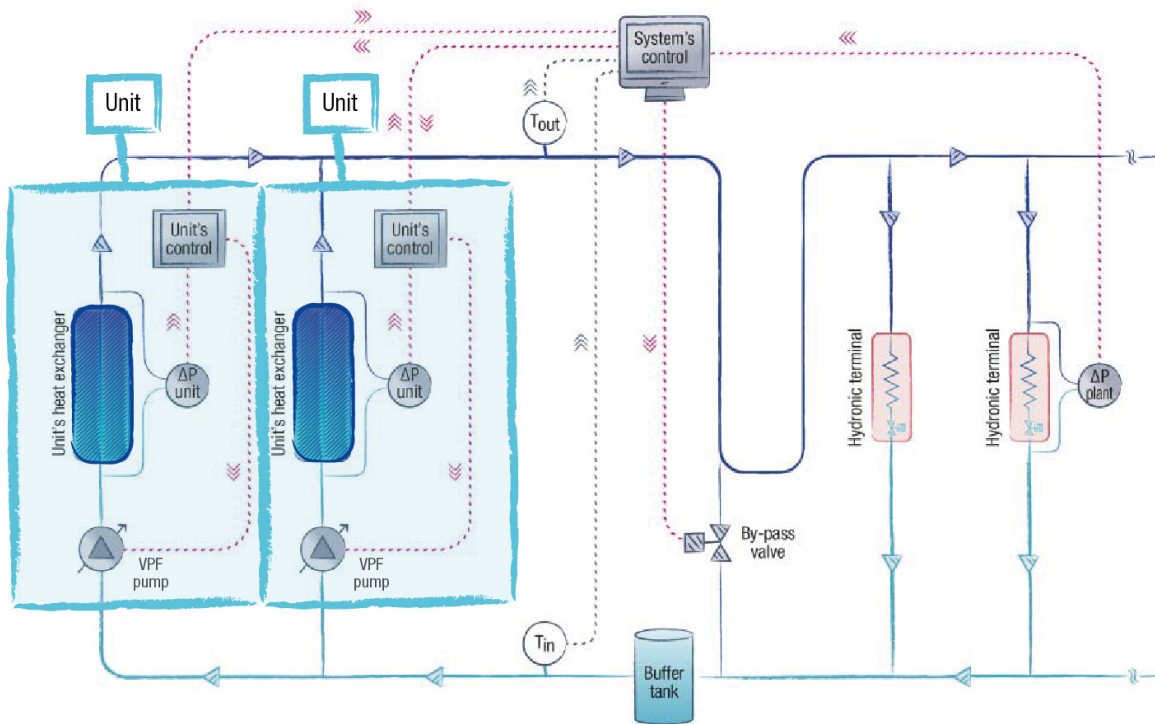

Plant diagram for multi-unit system with Multi Manager

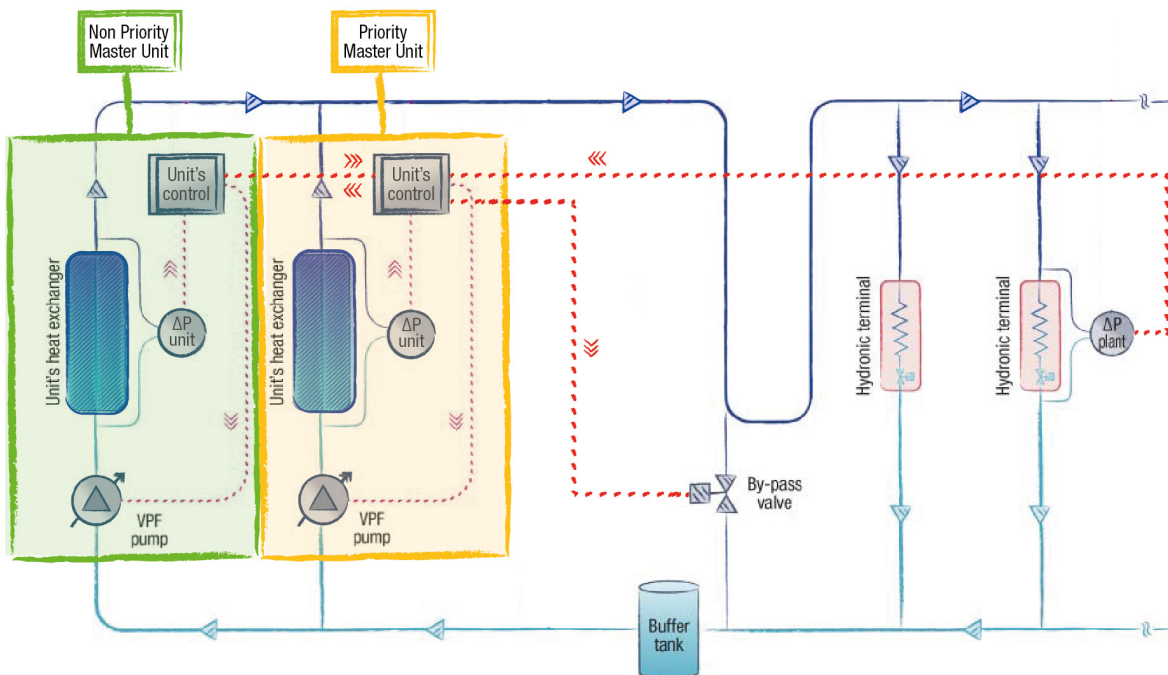

VPF - Operating logic

Water flow regulation

The VPF system monitors the differential pressure on the plant side (ΔP) and adjusts the pump speed in order to keep it within a defined range ($\Delta P_{min} \leftrightarrow \Delta P_{max}$).

- If $\Delta P_{min} \leq \Delta P \leq \Delta P_{max}$

The plant water flow is appropriate to the thermal load, the pump speed is kept constant.

- If $\Delta P > \Delta P_{max}$

The plant water flow exceeds what is necessary to properly cover the thermal load, the pump speed is reduced to save pump energy.

- If $\Delta P < \Delta P_{min}$

The plant water flow is too low to ensure the proper feed to the hydronic terminals, the pump speed is increased.

With the VPF system, the water flow can be reduced to 50% of the unit nominal water flow, with regards to the selection conditions, provided that the minimum water flow required by the unit's heat exchanger is respected (the control of the heat exchanger's minimum water flow is described below).

The pump speed regulation is performed with little progressive adjustments while continuously monitoring the values of both the delta P on the plant side and the water temperature on the heat exchanger. The absence of abrupt water flow changes prevents fluctuation due to possible conflicts with the unit's thermoregulation function (compressor regulation).

Control of the unit's minimum water flow

Under no circumstances can the primary circuit water flow be reduced below the minimum water flow required by the unit's heat exchanger. The monitoring of the unit's water flow is performed through a factory installed differential pressure transducer on the unit's heat exchanger. If the differential pressure on the plant side requests a users' water flow lower than the unit's minimum water flow, the VPF system commands the gradual opening of the hydraulic by-pass valve (safety function). This ensures that the minimum water flow required by the unit's heat exchanger is always provided. As soon as the hydronic terminals request an increase of the water flow ($\Delta P < \Delta P_{min}$), the VPF closes the by-pass valve.

Multi-unit systems

The VPF control logic is also the same for multi-unit systems. The plant side differential pressure transducer reading and the by-pass valve opening are managed by the multi-unit control system (Manager3000, ClimaPRO, Multi Manager Master). Each unit autonomously adjusts its pump speed on the basis of the information provided by the multi-unit control system. When the plant load requests the activation of a stand-by unit, the multi-unit control system calculates the starting speed of its pump in order to avoid excessive water flow variation of the running units.

In case of multi-unit system with Multi Manager, at least one unit must be set as Priority Master (opt 1541). To grant redundancy to the system, more than one unit can be configured as Priority Master. All the Priority Masters must be connected to the differential pressure transducer and the by-pass valve. The Multi Manager system only takes into account the signal read and sent by the Master of the moment (a specific filtering device is part of the supply; see the table below, note (8)).

The Non Priority Master cannot be connected to differential pressure transducer and by-pass valve and cannot managed the VPF function. In the event that a Non Priority Master is elected as the Master of the system, the VPF function is suspended.

VPF - Devices and installation

Device	Accessory name		
	VPF (w/o DP)(SU, MM_PR) ⁽¹⁾	VPF (w DP)(SU, MM_PR) ⁽²⁾	VPF (M3000, CPRO, MM_N-PR) ⁽³⁾
Differential pressure transducer on the unit's heat exchanger and related controller expansion board	Factory installed	Factory installed	Factory installed
Controller expansion board to read the plant side differential pressure transducer (4-20mA signal) and manage the hydraulic by-pass valve opening (0-10V signal)	Factory installed	Factory installed	Factory installed on the multi-unit external control system (Manager3000, ClimaPRO) Not included with option 1542 (Non Priority Master unit) ⁽⁵⁾
Plant side differential pressure transducer	Not included (the supply is the customer's responsibility) ⁽⁴⁾	Factory supplied, installation is the client's responsibility ⁽⁴⁾⁽⁵⁾	Factory supplied with the multi-unit external control system (Manager3000, ClimaPRO); installation is the client's responsibility Not included with option 1542 (Non Priority Master unit) ⁽⁴⁾⁽⁶⁾
Plant side hydraulic by-pass valve	Not included (the supply is the customer's responsibility) ⁽⁷⁾⁽⁸⁾	Not included (the supply is the customer's responsibility) ⁽⁷⁾⁽⁸⁾	Not included (the supply is the customer's responsibility) ⁽⁷⁾

(1) VPF for unit without plant differential pressure transducer included (for single unit plant and Priority Master unit)

(2) VPF for unit with plant differential pressure transducer included (for single unit plant and Priority Master unit)

(3) VPF for multi-unit plant with external controller (Manager3000, ClimaPRO) and Non Priority Master unit

(4) It is recommended to install the differential pressure transducer on the most hydraulically critical hydronic terminal, to ensure it has a proper water flow in any load condition.

(5) Technical features of the differential pressure transducer supplied:

Model: Huba Control 692.9 120071C1

Pressure range: 0 ... + 1 bar

Output: 4-20mA

Electrical connection: DIN EN 175301-803-A (IP 65)

Pressure connection adapters: male threaded G 1/8"

(6) It is the customer's responsibility to configure the multi-unit control system (Manager3000, ClimaPRO or Multi Manager) with option VPF.

(7) See attached table for information on the hydraulic by-pass design.

(8) In case of a multi-unit plant with more than one Master Priority unit (opt 1541) please specify it when emailing our sales. An additional device will be add to manage the multiple signals coming from unit's controller to the by-pass valve.

The following table provides the indications for a correct hydraulic by-pass design.

Heat exchanger minimum flow (m ³ /h) ⁽¹⁾	Minimum by-pass diameter	Minimum by-pass valve diameter	Suggested valve model	Kvs	Suggested actuator model
From 19 to 30	DN50 (2")	DN50 (2")	VVG41.50	40	SKB60
Up to 37	DN65 (2" ½)	DN65 (2" ½)	VVF31.65	49	SKB60
Up to 60	DN80 (3")	DN80 (3")	VVF31.80	78	SKB60
Up to 95	DN100 (4")	DN100 (4")	VVF31.90	124	SKC60
Up to 150	DN125 (5")	DN125 (5")	VVF31.91	200	SKC60
Up to 230	DN150 (6")	DN150 (6")	VVF31.92	300	SKC60

(1) In case of a multi-unit system, the unit with the highest minimum water flow should be the reference.

VPF.D SYSTEM (delta T control)

For plants with primary and secondary circuits separated by a hydraulic decoupler.

VPF.D - Plant and unit requirements

The VPF.D logic provides the variable flow control for the plant's primary circuit.

- Type of plant: primary and secondary circuits separated by a hydraulic decoupler
- Hydronic module: modulating regulation devices (0-10V signal) or variable speed pumps
- Unit thermoregulation: control of the leaving water temperature
- Monitored parameter: delta T on primary circuit

Plant diagram for single unit system

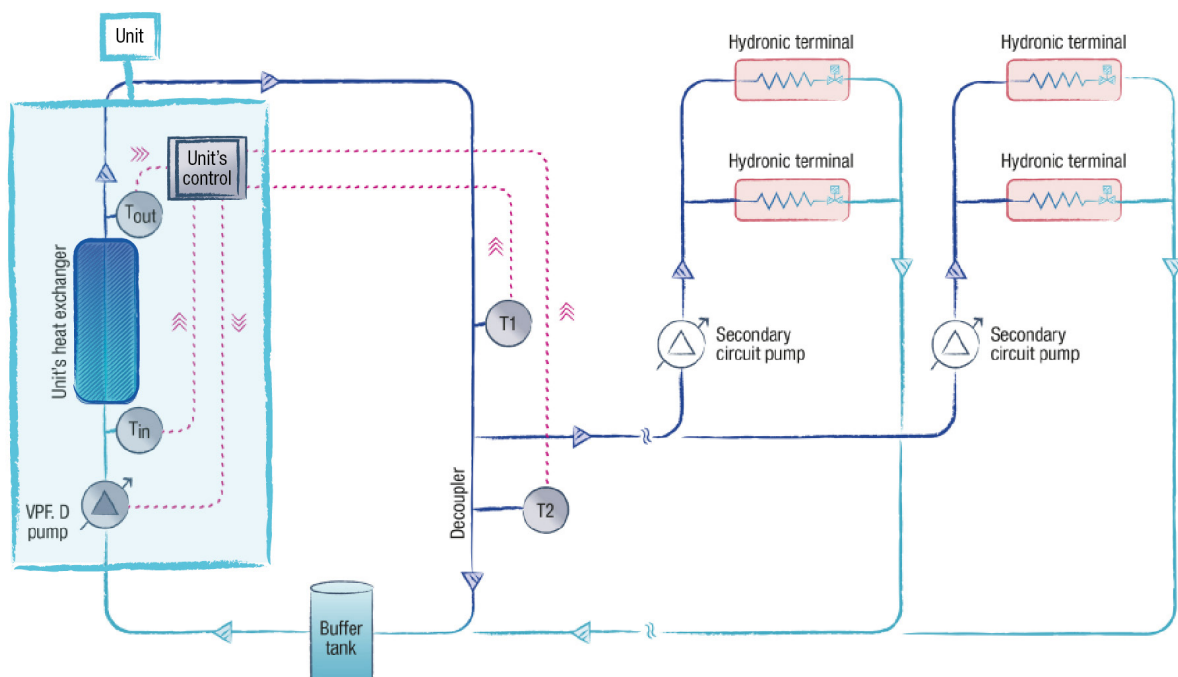

Plant diagram for multi-unit with external control system (Manager3000 or ClimaPRO)

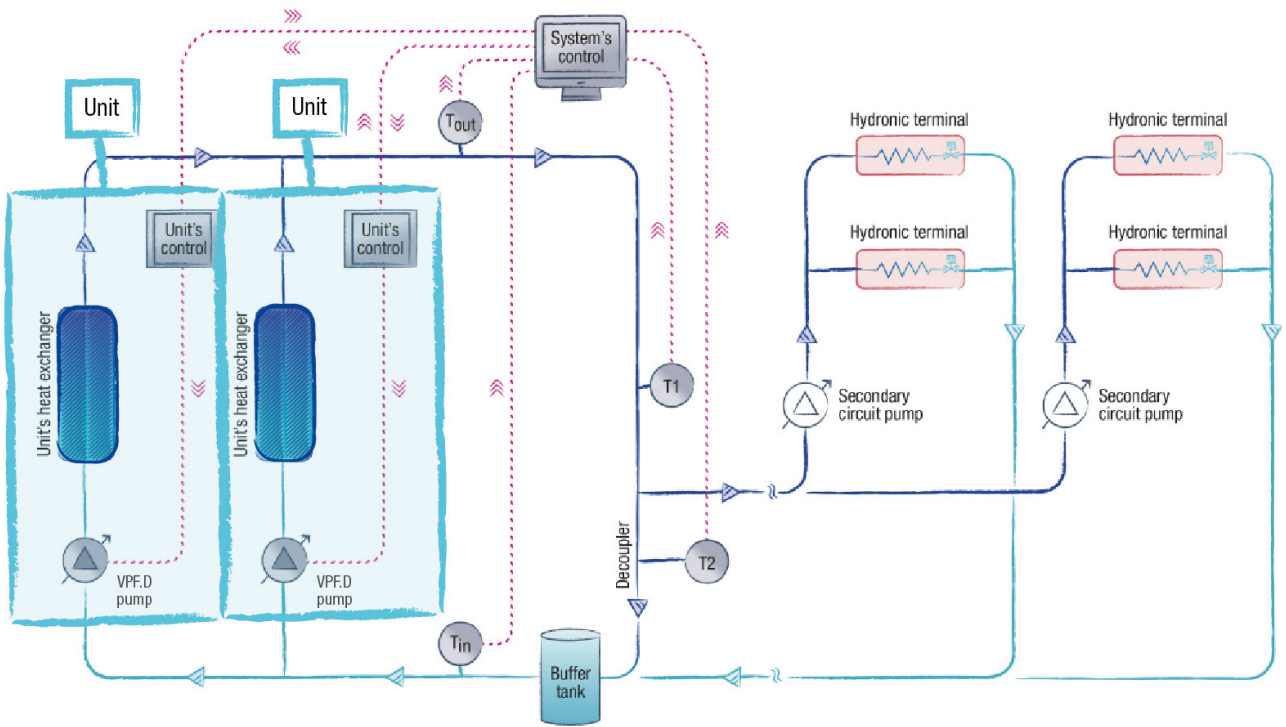

Plant diagram for multi-unit system with Multi Manager

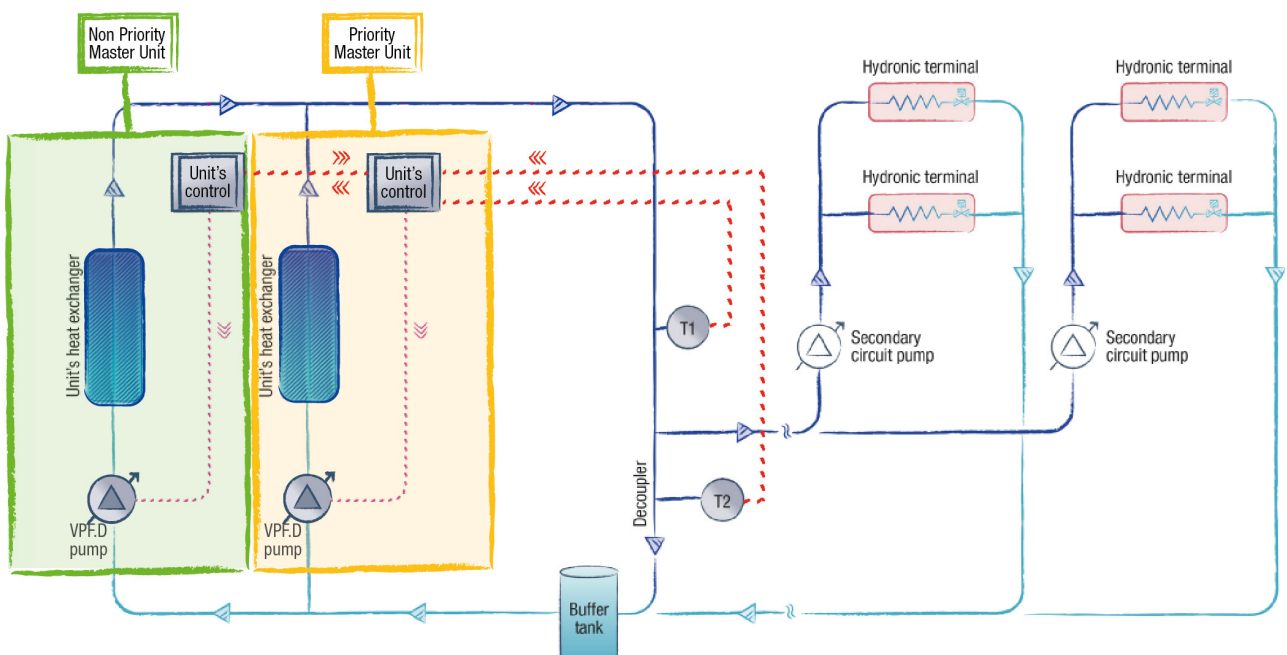

VPF.D - Operating logic

Water flow regulation

The VPF.D system monitors the temperature difference of the primary circuit (ΔT) (that corresponds to the temperature difference of the unit's heat exchanger in the case of a single unit system), and adjusts the primary circuit's pump speed in order to keep it within a defined range ($\Delta T_{min} \leftrightarrow \Delta T_{max}$). The secondary circuit water flow is completely independent and is to be managed by the client.

- If $\Delta T_{min} \leq \Delta T \leq \Delta T_{max}$
The plant water flow is appropriate to the thermal load, the pump speed is kept constant.
- If $\Delta T < \Delta T_{min}$
The plant water flow exceeds what is necessary to properly cover the thermal load, the pump speed is reduced to save pump energy.
- If $\Delta T > \Delta T_{min}$
The plant water flow is too low to ensure the proper feed to the users, the pump speed is increased.

To prevent the returning water of the secondary circuit from recirculating through the decoupler and mixing with the delivery water, which would cause serious plant regulation problems, the VPF.D provides a safety function based on the temperatures, which are detected by two probes on the plant side: T1 on the unit delivery line and T2 on the hydraulic decoupler. If during the water flow regulation of the circuits, the flow direction in the decoupler reverses (detected temperatures $T1 < T2$), the system forces a quick increase of the primary water flow until the correct direction of the flow in the decoupler is restored (detected temperatures $T1 = T2$).

With the VPF.D system, the water flow can be reduced to 50% of the unit nominal water flow, with regards to the selection conditions, provided that the minimum water flow required by the unit's heat exchanger is respected (the control of the heat exchanger's minimum water flow is described below).

The pump speed regulation is performed with little progressive adjustments while continuously monitoring the values of both the temperature difference on the primary circuit and the temperatures of the probes T1 and T2. The absence of abrupt water flow changes prevents fluctuation due to possible conflicts with the unit's thermoregulation function (compressor regulation).

Control of the unit's minimum water flow

Under no circumstances can the primary circuit water flow be reduced below the minimum water flow required by the unit's heat exchanger. The unit's minimum water flow is ensured by setting the minimum pump speed (service menu parameter).

Multi-unit systems

The VPF.D control logic is also the same for multi-unit systems. The reading of the temperature difference on the primary circuit and the reading of the temperature probes T1 and T2 is managed by the multi-unit control system (Manager3000, ClimaPRO, Multi Manager Master).

Each unit autonomously adjusts its pump speed on the basis of the information provided by the multi-unit control system.

When the plant load requests the activation of a stand-by unit, the multi-unit control system calculates the starting speed of its pump in order to avoid excessive water flow variation of the running units.

In case of multi-unit system with Multi Manager, at least one unit must be set as Priority Master (opt 1541). To grant redundancy to the system, more than one unit can be configured as Priority Master. All the Priority Masters must be connected to the temperature probes T1 and T2. The Multi Manager system only takes into account the signal read and sent by the Master of the moment.

The Non Priority Master cannot be connected to the temperature probes T1 and T2, and cannot managed the VPF.D function. In the event that a Non Priority Master is elected as the Master of the system, the VPF.D function is suspended.

VPF.D - Devices and installation

Dispositivo	Accessory name	
	VPF.D (SU, MM_PR) ⁽¹⁾	VPF.D(M3000, CPRO, MM_N-PR) ⁽²⁾
2 plant side NTC temperature sensors and related controller expansion board	Factory supplied (probes supplied without wells), installation is the client's responsibility ⁽³⁾	Factory supplied with the multi-unit external control system, Manager3000 or ClimaPRO (probes supplied without wells); installation is the client's responsibility Not included with option 1542 (Non Priority Master unit) ⁽³⁾⁽⁴⁾

(1) VPF.D for single unit plant and Priority Master unit

(2) VPF.D for multi-unit plant with external controller (Manager3000 or ClimaPRO) and Non Priority Master unit

(3) It is recommended to install the temperature probes as shown in the enclosed plant diagrams (T1 on the unit delivery line, T2 on the hydraulic decoupler)

(4) It is the customer's responsibility to configure the multi-unit control system (Manager3000, ClimaPRO or Multi Manager) with option VPF.D.

The following table provides the indications for a correct hydraulic decoupler design.

Heat exchanger minimum flow (m ³ /h) ⁽¹⁾	Minimum hydraulic decoupler diameter
From 25 to 40	DN65 (2" ½)
Up to 60	DN80 (3")
Up to 100	DN100 (4")
Up to 150	DN125 (5")
Up to 225	DN150 (6")
Up to 375	DN200 (8")

(2) In case of a multi-unit system, the unit with the highest minimum water flow should be the reference.



for a greener tomorrow

Eco Changes is the Mitsubishi Electric Group's environmental statement, and expresses the Group's stance on environmental management. Through a wide range of businesses, we are helping contribute to the realization of a sustainable society.



MITSUBISHI ELECTRIC HYDRONICS & IT COOLING SYSTEMS S.p.A.

Head Office: Via Caduti di Cefalonia 1 - 36061 Bassano del Grappa (VI) - Italy

Tel (+39) 0424 509 500 - Fax (+39) 0424 509 509

www.melcohit.com

