

Data Book



NX-Q-G06 0604 - 1204_202003_EN R454B
ELCA_Engine ver.4.4.0.0

NX-Q-G06 0604 - 1204

136-298 kW

INTEGRA unit for 4-pipe systems, air source for outdoor installation



(The photo of the unit is indicative and may vary depending on the model)

- ✓ **UNIQUE PROPOSAL**
- ✓ **LOW GWP REFRIGERANT**
- ✓ **ENERGY SAVING**

- ✓ **ErP READY**
- ✓ **INTEGRATED HYDRONIC GROUP**
- ✓ **WIDE OPERATING RANGE**

CERTIFICATIONS

Product certifications



Voluntary product certifications



Check ongoing validity of certificate:

www.eurovent-certification.com

or

www.certiflash.com

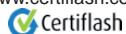

System certifications



MITSUBISHI ELECTRIC HYDRONICS & IT COOLING SYSTEMS S.p.A.

Quality System complying with the requirements of UNI EN ISO 9001:2008 regulation
Environmental Management System complying with the requirements of UNI EN ISO 14001:2004 regulation
Occupational Health and Safety Management System complying with the requirements of BS OHSAS 18001:2007

1.1	PRODUCT FEATURES	pg.1.1.1 / 1.1.3
2.1	PRODUCT PRESENTATION	pg.2.1.1 / 2.1.1
3.1	INCIPIT	pg.3.1.1 / 3.1.1
4.1	UNIT STANDARD COMPOSITION	pg.4.1.1 / 4.1.2
5.1	OPTIONS	pg.5.1.1 / 5.1.16
6.1	GENERAL TECHNICAL DATA	pg.6.1.1 / 6.1.3
7.1	TECHNICAL DATA SEASONAL EFFICIENCY IN HEATING (EN14825 VALUE)	pg.7.1.1 / 7.1.3
8.1	TECHNICAL DATA SEASONAL EFFICIENCY IN COOLING (EN14825 VALUE)	pg.8.1.1 / 8.1.0
9.1	OPERATING LIMITS	pg.9.1.1 / 9.1.3
10.1	HYDRAULIC DATA	pg.10.1.1 / 10.1.2
11.1	ELECTRICAL DATA	pg.11.1.1 / 11.1.3
12.1	FULL LOAD SOUND LEVEL	pg.12.1.1 / 12.1.6
13.1	DIMENSIONAL DRAWINGS	pg.13.1.1 / 13.1.3
14.1	HYDRONIC GROUP	pg.14.1.1 / 14.1.48

Liability disclaimer

The present publication is drawn up by of information only and does not constitute an offer binding upon Mitsubishi Electric Hydronics & IT Cooling Systems S.p.A.

Mitsubishi Electric Hydronics & IT Cooling Systems S.p.A. has compiled the content of this publication to the best of its knowledge. The data contained herein are subject to change without notice. Mitsubishi Electric Hydronics & IT Cooling Systems S.p.A. explicitly rejects any liability for any direct or indirect damage, in the broadest sense, arising from or related to the use and/or interpretation of this publication. All content is copyrighted by Mitsubishi Electric Hydronics & IT Cooling Systems S.p.A.

The units highlighted in this publication contain R454B [GWP₁₀₀ 466] fluorinated greenhouse gases.

Functions



Combined production of heating and cooling

Refrigerant



R454B

Compressors



Scroll compressor

Fan



Axial fan

Exchangers



Plates heat exchanger

Other features



Eurovent

1.1 PRODUCT FEATURES

2.1 GREEN CERTIFICATION RELEVANT

Mitsubishi Electric Hydronics & IT Cooling Systems S.p.A., as a major player in the world HVAC market and a leading manufacturer of energy efficient, sustainable HVAC solutions, recognizes and supports the diffusion of green certification systems, as an effective way to deliver high performance buildings and improve the quality and the sustainability of the built environment.

Since the first certification system was introduced at the beginning of the 1990s, the demand for certified buildings has grown considerably, as well as the number of standards, rating and certification programs. Operating worldwide Mitsubishi Electric Hydronics & IT Cooling Systems S.p.A., has extensive experience with many of them and is active member of Green Building Council Italy.

Mitsubishi Electric Hydronics & IT Cooling Systems S.p.A., commitment to develop responsible and sustainable HVAC solutions, is reflected by a full range of premium efficiency products and systems, designed with special care to improve building energy performance ratings, according to major certification protocols, including LEED, BREAM, GREENSTAR, BCA, NABERS, DNGB, HQE and BEAM.

To find out more about how our products contribute to enhanced green certification rating and energy performance of a building, please refer to:

https://www.melcohit.com/EN/Environment/green_certifications/



PRODUCT FEATURES

1.2 FOCUS ON: 4 PIPE SYSTEMS

This type of system is suitable for air-conditioning buildings that require separate areas to be heated and cooled at the same time.

It is combined with centralised solutions capable of producing hot and cold water in the two hydronic circuits of the system, assuring maximum comfort in every room of the building, independently and in any period of the year.

From now on, a single intelligent unit is sufficient for the management of these complex systems: INTEGRA.

1.3 INTEGRA UNIT FOR 4-PIPE SYSTEMS, AIR SOURCE FOR OUTDOOR INSTALLATION

The series multi-use units are able to simultaneously meet hot and cold water production requests and are thus a valid alternative to traditional systems based on chillers and boilers for applications such as office blocks, pools and shopping centres. The advanced control logic, developed by MEHITS, ensures that heating and cooling loads are perfectly met. When these are simultaneous, the unit exchanges evaporation and condensation heat with the system cooling and heating circuits respectively. When heat loads are not balanced or one of the two are missing, the unit automatically switches to a third heat source which can be air or water according to the model.

This unit for outdoor installation. For these products heat is exchanged on the source side by a refrigerant air coils exchanger, it acts as a condenser or as an evaporator according to mode function.

1.4 INTEGRA, THE VERSATILE AND MULTI-FUNCTIONAL HEAT PUMP FOR ALL APPLICATIONS

The INTEGRA units are used in many applications, even completely different from each other, for the versatility and flexibility that distinguishes them.

Many years of experience in these applications has led MEHITS to develop its own solution to the main challenges posed by comfort, industrial processes up to IT Cooling applications, without making any compromises.

1.5 Comfort Applications

Perfect for mixed-use buildings, residential applications, environments with complex and variable thermal loads, areas with large glass surfaces. To cool and simultaneously heat mixed-use environments is a frequent trend in the building and constructions segment. In these cases, the use of a smart INTEGRA heat pumps is key for producing hot and cold water simultaneously and independent matching any kind of load combinations whilst ensuring optimal comfort and highest energy efficiency all year long.

- Auto adaptability to variable loads
- Highest efficiency in all load conditions
- Plant simplification and reduction of technical spaces
- A gas network is no longer needed
- Smart management of thermal energy

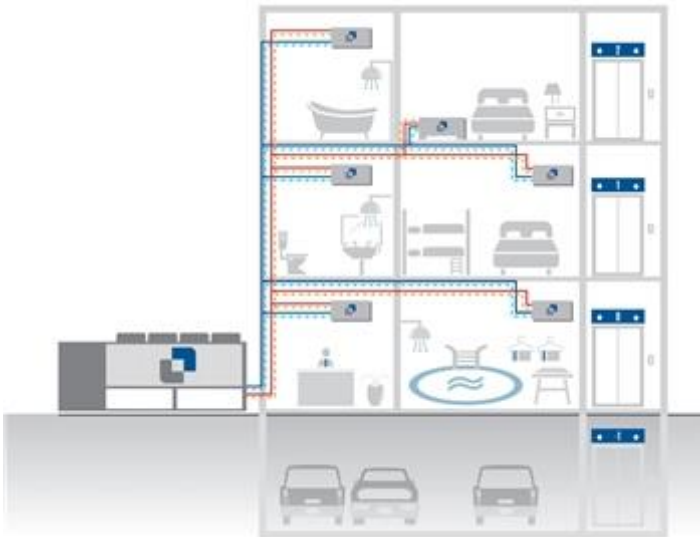

1.6 WORKING PRINCIPLE

The main feature of INTEGRA units is the ability to manage the overall capacity of both the cooling and heating side, based on the actual load requirements of the total system. The operational flexibility is total: all the

combinations of heating and cooling loads can be met. A smart heat pump is a simple and integrated response to all the applications requiring independent cooling and heating simultaneously, such as air-conditioning requirements for large plants with complex loads.

Four operating modes for INTEGRA units are described below.

1.7 Operating mode: 100% cold side / 100% hot side

The two circuits operate at maximum power, evaporating in the cold-side exchanger and condensing in the hot-side one. The source-side heat exchanger (air coil or water exchanger, depending on the unit type) is not used, which means that in these conditions there is no energy waste.

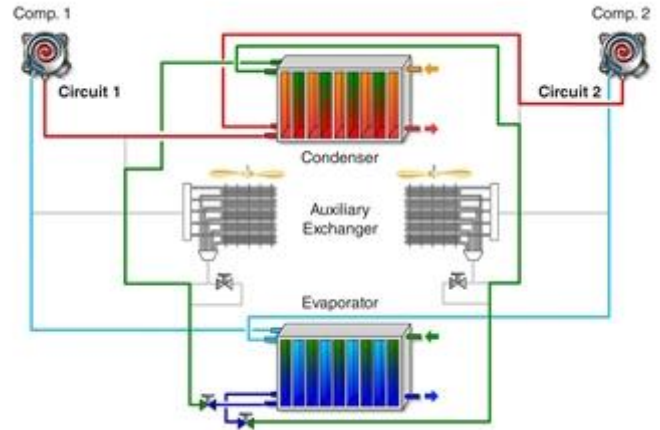

1.8 Operating mode: 50% cold side / 50% hot side

Also in this situation, the unit operates like a water-water unit, as all the evaporating and condensing energy is used for the system. Since the system only requires 50% of the total energy, each circuit operates in partial load conditions. In this particular condition, the exchangers are oversized, thus achieving even higher efficiency.

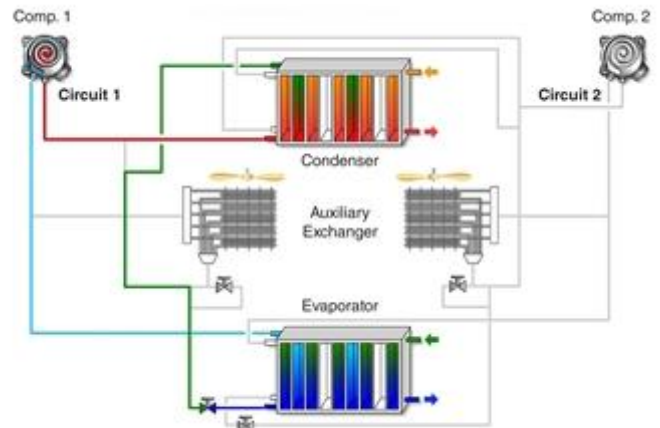

1.9 Operating mode: 100% cold side / 50% hot side

Both the circuits operate to produce the amount of energy necessary for the cooling of the plant, evaporating all the refrigerant in the cold-side heat exchanger. While one circuit carries out the condensation on the hot-side heat exchanger, thus supplying the total energy necessary to heat the building, the other circuit exchanges the remaining heating energy in the external environment by using the auxiliary source-side heat exchanger (air coil or water exchanger, depending on the unit type).

PRODUCT FEATURES

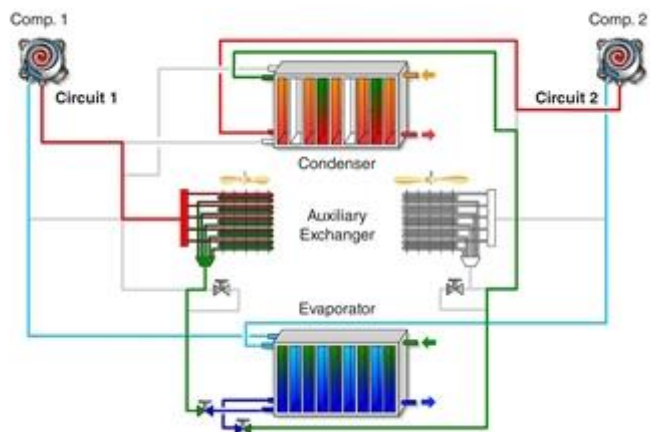

1.10 Operating mode: 50% cold side / 100% hot side

Just like the latter case, in this condition both circuits operate differently, to supply the system with the correct amount of required energy. The unit uses two sources to produce the requested hot water flow: in fact, one circuit evaporates the refrigerant in the cold-side heat exchanger, thus supplying the cold water demand, while the other uses the auxiliary source-side heat exchanger. In this way both circuits move energy in the hot-side heat exchanger, fulfilling the request for hot water flow.

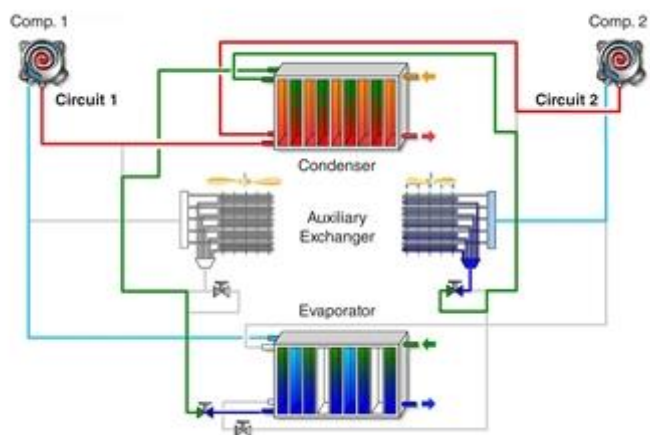

2.1 PRODUCT PRESENTATION

Multi-purpose outdoor unit for use in 4-pipe systems for the simultaneous production of chilled and hot water by means of two independent hydronic circuits. These units are able to satisfy the demand for hot and cold water simultaneously through a system that does not require seasonal switching and is therefore a valid alternative to traditional plants with chiller and boiler. Unit with two independent refrigerant circuits, each equipped with two hermetic rotary Scroll compressors, low-GWP and ozone-friendly refrigerant R454B, axial fans, braze-welded plate-type exchanger and thermal expansion valve. External panels in Peraluman and base in galvanised sheet steel with paint finish.

2.3 UNIQUE PROPOSAL

Unit designed to satisfy the cold and the hot side requirements simultaneously, for 4-pipe systems without any particular operation mode setting

2.4 LOW GWP REFRIGERANT

The new generation refrigerant R454B is the most eco-sustainable alternative to traditional refrigerant R410A, offering a 76% reduction in terms of GWP (Global Warming Potential GWP of R454B = 466, GWP of R410A = 1924 as per IPCC rev. 5th) and zero impact on the ozone layer.

2.5 ENERGY SAVING

Energy saving guaranteed by the advanced operation's logic. The best operation mode is set completely automatically and independently by the unit's controller, in order to minimize the absorbed energy whatever the cooling and/or heating demand might be

2.6 ErP READY

The highest level of efficiency at part load can meet and exceed the minimum seasonal efficiency for heating, SCOP according with the eco-sustainable design requirements for all products using energy.

2.7 INTEGRATED HYDRONIC GROUP

The built-in hydronic module already contains the main water circuit components; it is available with single or twin in-line pump, for achieving both low or high head, fixed or variable speed, available for both plant and recovery circuits (up to 4 pumps).

2.8 WIDE OPERATING RANGE

The units are operative at full load in heat pump mode down to -15°C outdoor air temperature, and up to 46°C in chiller mode without needing additional options. Furthermore, hot water can be provided up to 52°C, and at -15°C outdoor air temperature, the units can produce hot water up to 40°C at full load.

NX-Q-G06 / SL 1204

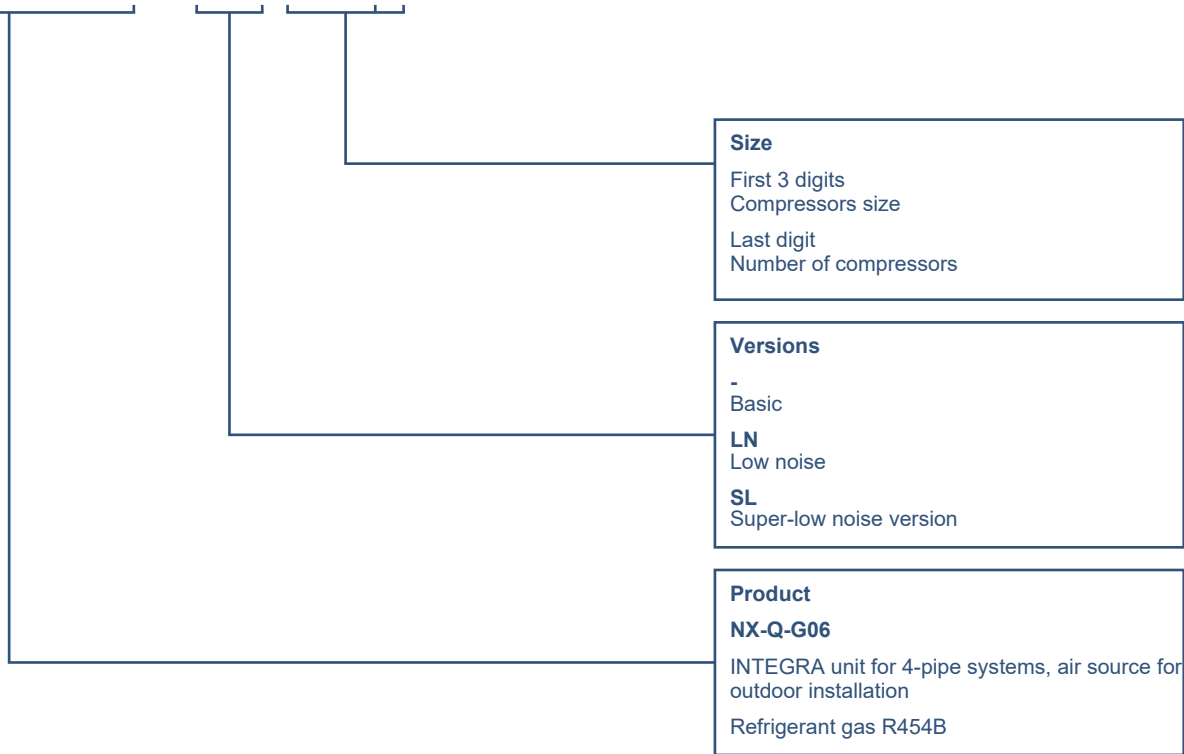

4.1 UNIT STANDARD COMPOSITION

4.2 INTEGRA unit for 4-pipe systems, air source for outdoor installation

Multi-purpose outdoor unit for use in 4-pipe systems for the simultaneous production of chilled and hot water by means of two independent hydronic circuits. These units are able to satisfy the demand for hot and cold water simultaneously through a system that does not require seasonal switching and is therefore a valid alternative to traditional plants with chiller and boiler. Unit with two independent refrigerant circuits, each equipped with two hermetic rotary Scroll compressors, low-GWP and ozone-friendly refrigerant R454B, axial fans, braze-welded plate-type exchanger and thermal expansion valve. External panels in Peraluman and base in galvanised sheet steel with paint finish.

4.3 R454B REFRIGERANT

The refrigerant used in these units is R454B, one of the most eco-sustainable refrigerants for replacing traditional R410A, thanks to the 76% lower GWP.

Unlike R410A, R454B is classified as A2L according to ISO 817. The first digit defines toxicity (A: NON-TOXIC), while the last digits define the flammability level (2L: MILDLY FLAMMABLE - low burning velocity). It is classified by PED Directive into Group 1.

The main characteristics of this refrigerant and some additional guidelines are reported below. Despite the minimal risk, the indications provided cannot replace a more detailed risk analysis if required, also based on any regulations in force in the installation area.

Further and more detailed guidelines are available in the dedicated area of the website www.melcohit.com (Guidelines) or in the dedicated addendum of the general installation and maintenance manual.

Main characteristics of R454B refrigerant:

- Safety classification (ASHRAE / ISO 817): A2L
- PED Group: 1
- Ozone Depletion Potential (ODP) (R11=1): 0
- AR5 (AR4) GWP (CO2=1): 467 (466)
- Composition (Wt %): 68,9% R32, 31,1% R1234yf
- LFL@23°C, 50% RH (% v/v): 11,7
- UFL@23°C, 50% RH (% v/v): 22,0
- Burning velocity (cm/s): 5,2
- Minimum Ignition Energy (mJ) (ASTM E582-13): 100-300

• All operations on the unit must be performed by trained and qualified personnel on flammable refrigerants handling, in accordance with the relevant local standards and codes of practice.

• The refrigerant is heavier than air and can stagnate, reaching a dangerous concentration. To avoid risks, maintain a safe environment by ensuring adequate ventilation.

• The units must be installed in such a way as to prevent any refrigerant leaks from flowing into the buildings or any place where it could cause damage to people, animals or properties. Pay particular attention to the presence and disposition of any external air intakes, doors, shutters, etc.

• The units are equipped with conveyed safety valves with external discharge. In case of over-pressure, refrigerant gas can escape from these valves: the discharge of these ducts must be directed towards safe areas and away from the ground or potential sources of ignition.

• Do not braze pipes and components containing refrigerant.

• Do not use flames to cut / open pipes.

• The units are equipped with a safety valve (water side). In case of breakage of the heat exchanger and resulting overpressure, refrigerant gas can escape from these valves: the discharge of these valves must be directed towards safe areas and away from the ground or potential sources of ignition.

• The hydraulic circuit must be designed in such a way as to prevent the release of refrigerant gas inside the buildings or in any case in places where it can cause damage to people, animals or properties.

4.4 Structure

Frame with base in polyester-painted thick hot-galvanised sheet steel. Shaped aluminium walls.

4.5 Panelling

The external panelling, made from simil peraluman, epoxy painted sheet metal, offers maximum ease of access to the internal components.

4.6 Refrigerant circuit

Main components of the cooling circuit:

- R454B refrigerant
- liquid line shut-off valve
- liquid line solenoid valve
- drier filter with replaceable cartridge
- refrigerant line sight glass with humidity indicator
- externally equalised thermostatic valve

- liquid receivers
- liquid separators
- electrovalves for circuit configuration
- safety switching device for limiting the pressure
- high and low pressure transducers
- crankcase heater on each compressor
- 4-way reverse cycle valve
- high and low pressure safety valves, conveyed to external discharge

4.7 Compressor

Hermetic scroll compressors complete with an oil sump heater, electronic overheating protection with centralised manual reset and a two-pole electric motor.

4.8 Plant side cold heat exchanger

Braze welded AISI 316 steel plate heat exchanger, it acts as an evaporator. The heat exchangers are lined on the outside with closed-cell neoprene lagging. When the unit is not operating, these are protected against formation of ice on the inside by an electric heater with thermostat, while when the unit is operating protection is ensured by a differential pressure switch on the water side. The unit can also operate with non-freezing mixes, down to heat exchanger outlet temperatures of -8°C.

4.9 Plant side hot heat exchanger

Braze welded AISI 316 steel plate heat exchanger, it acts as a condenser. The heat exchangers are lined on the outside with closed-cell neoprene lagging. When the unit is not operating, these are protected against formation of ice on the inside by an electric heater with thermostat, while when the unit is operating protection is ensured by a differential pressure switch on the water side.

4.10 Source side heat exchanger

Air-refrigerant heat exchanger, working as a condenser or an evaporator depending to the specific operating mode. Made with copper tubes and aluminium fins. The aluminium fins are spaced to guarantee the best heat exchange efficiency.

4.11 Fan section source side

Axial electric fans, protected to IP 54, with external rotor and pressed sheet metal blades. Housed in aerodynamic hoods complete with safety grille. 6-pole electric motor with built-in thermal protection. The fan chamber is divided into two sections. This improves efficiency with partial loads as the fans of the idle circuit can be stopped.

4.12 Electrical and control panel

Electrical and control panel built in accordance with EN60204-1 standard, complete with:

- control circuit transformer
- general door lock isolator
- fuses and contactors for compressors and fans
- terminals for cumulative alarm block
- remote ON/OFF terminals
- spring-type control circuit terminal board
- electric panel with double door and seals for outdoor installation
- Electronic control W3000+
- Pump control relay + 0-10V modulating signal to control an external variable speed pump with the VPF.E control logic (plant-side constant ΔT for plants with primary circuit only and terminals with bypass)

4.13 Certification and applicable directives

The unit complies with the following directives and relative amendments:

- EUROVENT Certification program
- CE Declaration of conformity certificate for the European Union
- Machinery Directive 2006/42/EC
- Pressure Equipment Directive 2014/68/EU
- 2014/30/EC EMC Directive
- ErP Directive 2009/125/EC

4.14 Tests

Tests performed throughout the production process, as indicated in ISO9001.

Performance or noise tests can be performed by highly qualified staff in the presence of customers.

Performance tests comprise the measurement of:

- electrical data
- water flow rates
- working temperatures
- power input
- power output
- pressure drops on the water-side exchanger both at full load (at the conditions of selection and at the most critical conditions for the condenser) and at part load conditions.

4.1 UNIT STANDARD COMPOSITION

During performance testing it is also possible to simulate the main alarm states.

Noise tests are performed to check noise emissions according to ISO9614.

4.15 Electronic control W3000+

The brand new W3000+ controller offers advanced functions and algorithms. The Large keypad, as standard equipment, features function controls and a complete LCD display for viewing data and activating the unit, via a multilevel menu, with settable display language. In addition to or as an alternative, the KIPlink is available - Keyboard In Your Pocket - is the innovative user interface based on WiFi technology that allows one to operate on the unit directly from the smartphone or tablet. Using KIPlink, it is possible to turn the unit on and off, adjust the set-point, plot the main operating variables, monitor in detail the status of the refrigerant circuits, the compressors, the fans and the pumps (if present) and display and reset the possible alarms. The regulation is based on the patented "Quickmind" water temperature regulation logic uses self-adapting control to maintain flow temperatures and optimise performance even in low water content scenarios. As an alternative, the proportional or proportional-integral regulations are also available. Diagnostics include complete alarm management, with "blackbox" functions (via PC) and alarm log (display or PC) for best analysis of unit behaviour. The built-in clock can be used to create an operating profile containing up to 4 typical days and 10 time bands, essential for efficient programming of energy production. Optional proprietary devices can perform the adjustment of the resources in systems made of several units. Consumption metering and performance measurement are possible as well. The variable primary flow control is always available as per standard (VPF.E function). Supervision is available with different options, using proprietary devices or by integration into third party systems using ModBus, BACnet, BACnet-over-IP and Echelon LonWorks protocols. A dedicated wall-mounted keypad can be used for remote control of all the functions.

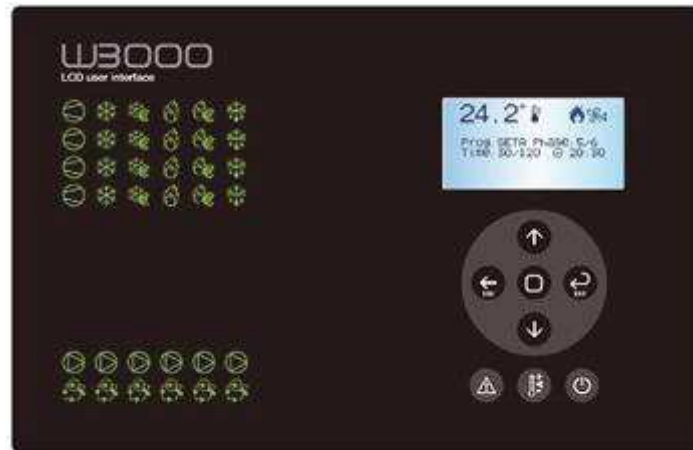

4.15 KIPlink - Keyboard In your Pocket (option 6196)

KIPlink - Keyboard In Your Pocket - is the innovative user interface based on WiFi technology that allows one to operate on the unit directly from the smartphone or tablet. Using KIPlink, it is possible to turn the unit on and off, adjust the set-point, plot the main operating variables, monitor in detail the status of the refrigerant circuits, the compressors, the fans (if present) and the pumps (if present) and display and reset the possible alarms.

4.15 Climatic curve (option 5941)

Available as option an outside air temperature probe to control the system water temperature set point based on cooling and heating (reversible units) climatic curves.

4.15 Night mode (option 1430)

The night mode function allows to reduce the sound power of the unit, reducing the speed of the fans and the number of active compressors.

4.15 U.L.C. - User limit control (option 4960)

Guaranteed the start-up of the units with the option U.L.C. even when the critical working condition could generate an alarm. The controller can manage a 3way mixing valve (not provided) by 0-10V signal for ensuring a dynamic control of the water temperature on user heat exchanger according to the operating limits allowed. This ensures the start-up and correct functioning of the unit into the envelope, also even critical whether condition.

5.1 OPTIONS

OPTIONS	DESCRIPTIONS	BENEFITS	AVAILABLE FOR MODELS
1470 MULTIFUNCTION CARD			
1431 NIGHT MODE	The option includes a related controller expansion board and dedicated terminal block.	Night mode is a system setting to limit maximum noise level of the unit. Noise level is reduced limiting maximum compressor frequency and fan speed.	ALL
1471 4951 + 1431	The option includes a related controller expansion board and dedicated terminal block.	Enables the functions corresponding to the indicated accessory codes.	ALL
1472 4951 + 1431 + 4961	The option includes a related controller expansion board and dedicated terminal block (it is necessary to install a 3 way valve).	Enables the functions corresponding to the indicated accessory codes.	ALL
1473 4951 + 4961	The option includes a related controller expansion board and dedicated terminal block (it is necessary to install a 3 way valve).	Enables the functions corresponding to the indicated accessory codes.	ALL
1474 1431 + 4961	The option includes a related controller expansion board and dedicated terminal block (it is necessary to install a 3 way valve).	Enables the functions corresponding to the indicated accessory codes.	ALL
1475 4962 + 4951	The option includes a related controller expansion board and dedicated terminal block (it is necessary to install a 3 way valve).	Enables the functions corresponding to the indicated accessory codes.	ALL
1476 4962 + 1431	The option includes a related controller expansion board and dedicated terminal block (it is necessary to install a 3 way valve).	Enables the functions corresponding to the indicated accessory codes.	ALL
1477 4962 + 4951 + 1431	The option includes a related controller expansion board and dedicated terminal block (it is necessary to install a 3 way valve).	Enables the functions corresponding to the indicated accessory codes.	ALL
4951 WITH HYDRAULIC DECOUPLER PROBE	Water temperature probe on hydraulic decoupler.	The pump activation can be set by parameter according to the water temperature on buffer tank measuring by the sensor (in the systems with the primary and secondary circuits separated by a hydraulic decoupler), thus bringing significant pump consumption reduction during unit's stand-by.	ALL
4961 U.L.C.F. - WITH OR WITHOUT FIX SPEED PUMP	Option to be selected with the unit without pump/s or with fix speed pump/s (4703,4706,4707,4711,4712). The option includes a related controller expansion board and dedicated terminal block.	Guaranteed the start-up of the units with the option U.L.C. even when the critical working condition could generate an alarm. The W3000TE controller can manage a 3way mixing valve (not provided from MEHITS) by 0-10V signal for ensuring a dynamic control of the water temperature on user heat exchanger according to the operating limits allowed. This ensures the start-up and correct functioning of the unit into the envelope, also even critical whether condition.	ALL
4962 U.L.C.F. - WITH VARIABLE WATER FLOW	Option to be selected with the unit with variable speed pump/s (4713,4714,4717,4718,4722,4723). The option includes a related controller expansion board and dedicated terminal block.	Guaranteed the start-up of the units with the option U.L.C. even when the critical working condition could generate an alarm. The W3000TE controller can manage a 3way mixing valve (not provided from MEHITS) by 0-10V signal for ensuring a dynamic control of the water temperature on user heat exchanger according to the operating limits allowed. This ensures the start-up and correct functioning of the unit into the envelope, also even critical whether condition.	ALL

OPTIONS

OPTIONS	DESCRIPTIONS	BENEFITS	AVAILABLE FOR MODELS
6190 TYPE OF VISUAL DISPLAY			
1444 KIPlink + LARGE KEYBOARD	The unit is equipped with KIPlink, the innovative user interface based on WiFi technology, and, in addition, the physical LCD keyboard.		ALL
6194 LARGE KEYBOARD	The unit is equipped with the Large keyboard with a wide LCD display and led icons.		ALL
6196 KIPlink	The unit is equipped with KIPlink, the innovative user interface based on WiFi technology		ALL
380 NUMBERED WIRING			
381 NUMBERED WIRING ON EL. BOARD	Electrical board wires are identified by numbered labels. The reference numbers are indicated in the unit's wiring scheme.	Facilitate maintenance interventions to the electrical board connections.	ALL
382 PWR WIRINGS ACC.TO UK REQUEST		Facilitate maintenance interventions to the electrical board connections.	ALL
383 NUMBERED WIRINGS+UK REQUESTS	Electrical board wires are identified by numbered labels. The reference numbers are indicated in the unit's wiring scheme.	Facilitate maintenance interventions to the electrical board connections.	ALL
2410 PHASE SEQUENCE RELAY			
2411 WITH EXTERNAL PHASE SEQUENCE RELAY	Relay for checking mains phase-sequence	Protects loads against faults due to incorrect connection of mains	ALL
2412 PHASE SEQU. RELAY + OVER/UNDER VOLT. MONIT.	Relay for checking mains phase-sequence and voltage	The monitoring relay protects loads against faults due to incorrect connection of mains, and it monitors whether it exceeds or falls below a specified voltage in a three-phase network.	ALL
3300 COMPRESSOR REPHASING			
3301 COMPR.POWER FACTOR CORR.	Capacitors on the compressors' power inlet line.	The unit's average cos(phi) increases.	ALL
3410 AUTOMATIC CIRCUIT BREAKERS			
3412 AUTOM. CIRCUIT BREAK. ON LOADS	Over-current switch on the major electrical loads.	In case of overcurrent allows resetting of the switch without the replacement of relative fuses.	ALL
3600 ON/OFF COMPRESSOR SIGNAL			
3601 COMPRESSOR OPERATION SIGNAL	Auxiliary contacts providing a voltage-free signal.	Allows remote signalling of compressor's activation or remote control of any auxiliary loads.	ALL
4180 REMOTE CONNECTION ARRANGEMENT			
4181 SERIAL CARD MODBUS	Interface module for ModBUS protocols.	Allows integration with BMS operating with ModBUS protocol.	ALL
4182 SERIAL CARD FOR LONWORKS	Interface module for Echelon systems.	Allows integration with BMS operating with LonWorks protocols	ALL
4184 SERIAL CARD BACNET MS/TP RS485	Interface module for BACnet protocols.	Allows integration with BMS operating with BACnet protocol.	ALL
4185 SERIAL CARD FOR BACNET OVER IP	Interface module for BACnet OVER-IP protocols.	Allows to interconnect BACnet devices over Internet Protocol within wide-area networks.	ALL

OPTIONS

OPTIONS	DESCRIPTIONS	BENEFITS	AVAILABLE FOR MODELS
4186 SERIAL CARD FOR KONNEX	Protocol for KNX system	Allows integration with BMS operating with KNX protocol	ALL
4188 SERIAL CARD MODBUS TCP/IP	Interface module for ModBus TCP/IP protocol	Allows integration with BMS operating with ModBus TCP/IP protocol.	ALL
4189 SERIAL CARD SNMP	Interface module for SNMP protocol	Allows integration with BMS operating with SNMP protocol.	ALL
6160 AUXILIARY INPUT			
6161 AUXILIARY SIGNAL 4-20mA	4-20 mA analog input	Allows to change the operating set-point according to the value of current applied to the analogue input.	ALL
6162 REMOTE SIGNAL DOUBLE SP	Allows to activate the Energy Saving set-point.	Allows to change the operating set-point according to a remote switch	ALL
6170 DEMAND LIMIT			
6171 INPUT REMOTE DEMAND LIMIT	Digital input (voltage free)	It permits to limit the unit's power absorption for safety reasons or in temporary situation.	ALL
1510 SOFT-STARTER			
1511 UNIT WITH SOFT-START	Electronic device adopted to manage the inrush current.	Break down of the inrush current compared to the direct motor start, lower motor windings' mechanical wear, avoidance of mains voltage fluctuations during starting, favourable sizing for the electrical system.	ALL
3430 REFRIGERANT LEAK DETECTOR			
3431 REFRIG. LEAK DETECTOR	Refrigerant leak detection system, supplied factory mounted and wired in the electrical board. In case of leak detection it will raise an alarm.	It promptly detects gas leakages	ALL
3433 GAS LEAK CONTACT + COMPR. OFF	Refrigerant leak detection system, supplied factory mounted and wired in the electrical board. In case of leak detection it will raise an alarm and stop the unit.	It promptly detects gas leakages and stops the unit	ALL
6310 VISUAL DISPLAY PROTECTION			
6311 WITH DISPLAY PROTECTION	Display protection sealed panel	Provide complete protection against UV rays, atmospheric agents, sand storms.	ALL
5920 MANAGEMENT & CONTROL SYSTEMS			
5922 ClimaPRO ModBUS RS485 - MID	This option includes all following devices on-board the unit panel: - MID certified network analyzer operating on ModBUS over RS-485 - Current transformers - W3000TE controller - Software release LA09 or later version.	This accessory allows to acquire the electrical data and the power absorbed by the unit and communicate with ClimaPRO via high level communication interface based on ModBUS over EIA RS-485. More specifically, the data collected are: power supply, current, frequency, power factor ($\cos\phi$), electrical power consumption, energy consumption. This specific energy meter model is MID certified and can therefore be used for billing applications. This option also ensures the compatibility between the units and ClimaPRO, thus allowing ClimaPRO to acquire all the main unit's operating variables and status by means of a high level communication interface to the controller installed onboard the unit panel.	ALL

OPTIONS

OPTIONS	DESCRIPTIONS	BENEFITS	AVAILABLE FOR MODELS
5923 ClimaPRO BacNET over IP	This option includes all following devices on-board the unit panel: - network analyzer operating on BACnet over IP - Current transformers - W3000TE controller - Software release LA09 or later version.	This accessory allows to acquire the electrical data and the power absorbed by the unit and communicate with ClimaPRO via high level communication interface based on BACnet over IP. More specifically, the data collected are: power supply, current, frequency, power factor ($\cos\phi$), electrical power consumption, energy consumption. This network analyzer is not MID certified and cannot therefore be used for billing applications. This option also ensures the compatibility between the units and ClimaPRO, thus allowing ClimaPRO to acquire all the main unit's operating variables and status by means of a high level communication interface to the controller installed onboard the unit panel.	ALL
5924 ENERGY METER FOR BMS	This option includes all following devices on-board the unit panel: - network analyzer with display operating on ModBUS protocol over RS-485 (without certification MID) - current transformers.	This accessory allows to acquire the electrical data and the power absorbed by the unit and send them via RS-485 bus to the BMS for energy metering.	ALL
5925 ENERGY METER FOR W3000	This option includes all following devices on-board the unit panel: - network analyzer with display, already cabled to unit's controller - current transformers.	This option allows to acquire the electrical data and the power absorbed by the unit. The figures are accessible through the unit's W3000 interface, and be sent to the BMS via several protocols by selecting the dedicated serial card in the option list.	ALL
1400 HP AND LP GAUGES			
1401 HP AND LP GAUGES	High and low pressure gauges	Allows immediate reading of the pressure values on both low and high pressure circuits	ALL
1900 COMPRESSOR SUCTION VALVE			
1901 COMPRESSOR SUCTION VALVE	Shut-off valve on compressor's suction circuit.	Simplifies maintenance activities	ALL
1910 COMPRESSOR DISCHARGE VALVE			
1911 COMPR. DISCHARGE LINE VALVE	Shut-off solenoid valve on compressor discharge circuit	Simplifies maintenance activities	ALL
890 CONDENSING COIL			
894 Cu PIPES/PREPAINTED ALL. FINS	Finned coil heat exchanger made from copper tubes and aluminum fins with chemical cleaning treatment to remove impurities, and then coated with protective paint with the following characteristics: - fins treated with protective polyester resin paint; - over 1000 hours of salt spray protection as per ASTM B117 (fins without cross and protected edges); - excellent resistance to UV rays.	Provide a good resistance against corrosion. For further information please refer to the Guidelines "Finned coil heat exchangers and protection against corrosion", available in the download section of the website www.melcohit.com/EN/Download/Corporate/ GUIDELINES or contact our sales department.	ALL
895 FIN GUARD SILVER TREATM	Copper-aluminum heat exchanger coils with polyurethane paint Fin Guard Silver SB. Coil completely coated by a protective layer of polyurethane paint with the following characteristics: - polyurethane paint with metallic emulsion; - over 3000 hours of salt spray protection as per ASTM B117; - excellent resistance to UV rays; - high-pressure spray painting system.	Provide a very high resistance against corrosion, also in very aggressive environment. For further information please refer to the Guidelines "Finned coil heat exchangers and protection against corrosion", available in the download section of the website www.melcohit.com/EN/Download/Corporate/ GUIDELINES or contact our sales department.	ALL

OPTIONS

OPTIONS	DESCRIPTIONS	BENEFITS	AVAILABLE FOR MODELS
2030 PROTECTION GRILL			
2032 COND. COIL PROTECTION NET	Covering metal net on the coil	Finned coil protection	ALL
820 FAN CONTROL			
801 PRESSOST. LOW AMBIENT CONTROL	Pressostatic control of the fans	Extension of the unit operating range (see the section dedicated to the operating limits). The device allows the unit to operate in the most extreme conditions avoiding any risk of low pressure alarm intervention. The enhanced air flow management delivers also benefits in terms of both efficiency and quietness.	ALL
802 VAR.FAN SPEED LOW AMB.CONTROL	Fan speed control according to the condensing pressure; the use of this device is mandatory in case the unit operates with low evaporator leaving water temperature combined with low outdoor air temperatures	Extension of the unit operating range (see the section dedicated to the operating limits). The device allows the unit to operate in the most extreme conditions avoiding any risk of low pressure alarm intervention. The enhanced air flow management delivers also benefits in terms of both efficiency and quietness.	ALL
808 EC FANS	Electronically commutated fans (EC fans). The brushless motor, governed by a special controller, continuously adjust fans' speed.	Reduced energy consumption and minimized current's absorption during start-up phase. The efficiency is increased by approximately: +1% of EER and +4/5% of ESEER. The noise reduces proportionally to the unit's partialization.	ALL
4700 EV - HYDRONIC MODULE			
4702 EV - RELAY 1 PUMP (ON/OFF)	Evaporator hydronic module, compatible with constant flow control. The unit is provided with 1 relay to control the activation of 1 external pump via single ON/OFF signal.	The hydronic module allows to control the external pumps with the unit controller logic.	ALL
4703 EV - RELAY 2 PUMPS (ON/OFF)	Evaporator hydronic module, compatible with constant flow control. The unit is provided with 2 relays to control the activation of 2 external pumps via double ON/OFF signal. The pumps are controlled in duty/standby, with running hours equalization and changeover on device failure.	The hydronic module allows to control the external pumps with the unit controller logic.	ALL
4704 EV - 1 PUMP 4P LH (FIX SPEED)	Evaporator hydronic module, compatible with constant flow control. The unit is provided with 1 fixed speed pump, with 4-pole motor. Residual head of 100 kPa approximately. Specifications and characteristic curves are available in the dedicated bulletin section.	The hydronic module includes the pumps and the main water circuit components, thus optimizing hydraulic and electrical installation space, time and costs.	ALL
4706 EV - 1 PUMP 2P LH (FIX SPEED)	Evaporator hydronic module, compatible with constant flow control. The unit is provided with 1 fixed speed pump, with 2-pole motor. Residual head of 100 kPa approximately. Specifications and characteristic curves are available in the dedicated bulletin section.	The hydronic module includes the pumps and the main water circuit components, thus optimizing hydraulic and electrical installation space, time and costs.	ALL
4707 EV - 1 PUMP 2P HH (FIX SPEED)	Evaporator hydronic module, compatible with constant flow control. The unit is provided with 1 fixed speed pump, with 2-pole motor. Residual head of 200 kPa approximately. Specifications and characteristic curves are available in the dedicated bulletin section.	The hydronic module includes the pumps and the main water circuit components, thus optimizing hydraulic and electrical installation space, time and costs.	ALL

OPTIONS

OPTIONS	DESCRIPTIONS	BENEFITS	AVAILABLE FOR MODELS
4708 EV - 2 PUMPS 4P LH (FIX SPEED)	Evaporator hydronic module, compatible with constant flow control. The unit is provided with 2 fixed speed pumps, with 4-pole motor. Residual head of 100 kPa approximately. The pumps are controlled in duty/standby, with running hours equalization and changeover on device failure. Specifications and characteristic curves are available in the dedicated bulletin section.	The hydronic module includes the pumps and the main water circuit components, thus optimizing hydraulic and electrical installation space, time and costs.	ALL
4711 EV - 2 PUMPS 2P LH (FIX SPEED)	Evaporator hydronic module, compatible with constant flow control. The unit is provided with 2 fixed speed pumps, with 2-pole motor. Residual head of 100 kPa approximately. The pumps are controlled in duty/standby, with running hours equalization and changeover on device failure. Specifications and characteristic curves are available in the dedicated bulletin section.	The hydronic module includes the pumps and the main water circuit components, thus optimizing hydraulic and electrical installation space, time and costs.	ALL
4712 EV - 2 PUMPS 2P HH (FIX SPEED)	Evaporator hydronic module, compatible with constant flow control. The unit is provided with 2 fixed speed pumps, with 2-pole motor. Residual head of 200 kPa approximately. The pumps are controlled in duty/standby, with running hours equalization and changeover on device failure. Specifications and characteristic curves are available in the dedicated bulletin section.	The hydronic module includes the pumps and the main water circuit components, thus optimizing hydraulic and electrical installation space, time and costs.	ALL
4713 EV - RELAY 1 PUMP + 0-10V SIG	Evaporator hydronic module, compatible with constant or variable flow control. The unit is provided with 1 relay and a 0-10V signal terminal to control the activation and the speed of 1 external variable speed pump.	The hydronic module allows to control the external pumps with the unit controller logic.	ALL
4714 EV - RELAY 2 PUMPS + 0-10V SIG	Evaporator hydronic module, compatible with constant or variable flow control. The unit is provided with 2 relays and a 0-10V signal terminal to control the activation and the speed of 2 external variable speed pump. The pumps are controlled in duty/standby, with running hours equalization and changeover on device failure.	The hydronic module allows to control the external pumps with the unit controller logic.	ALL
4717 EV - 1 PUMP 2P LH (VAR SPEED)	Evaporator hydronic module, compatible with constant or variable flow control. The unit is provided with 1 variable speed pump, with 2-pole motor. Residual head of 100 kPa approximately. Specifications and characteristic curves are available in the dedicated bulletin section.	The hydronic module includes the pumps and the main water circuit components, thus optimizing hydraulic and electrical installation space, time and costs.	ALL
4718 EV - 1 PUMP 2P HH (VAR SPEED)	Evaporator hydronic module, compatible with constant or variable flow control. The unit is provided with 1 variable speed pump, with 2-pole motor. Residual head of 200 kPa approximately. Specifications and characteristic curves are available in the dedicated bulletin section.	The hydronic module includes the pumps and the main water circuit components, thus optimizing hydraulic and electrical installation space, time and costs.	ALL

OPTIONS

OPTIONS	DESCRIPTIONS	BENEFITS	AVAILABLE FOR MODELS
4722 EV - 2 PUMPS 2P LH (VAR SPEED)	Evaporator hydronic module, compatible with constant or variable flow control. The unit is provided with 2 variable speed pumps, with 2-pole motor. Residual head of 100 kPa approximately. The pumps are controlled in duty/standby, with running hours equalization and changeover on device failure. Specifications and characteristic curves are available in the dedicated bulletin section.	The hydronic module includes the pumps and the main water circuit components, thus optimizing hydraulic and electrical installation space, time and costs.	ALL
4723 EV - 2 PUMPS 2P HH (VAR SPEED)	Evaporator hydronic module, compatible with constant or variable flow control. The unit is provided with 2 variable speed pumps, with 2-pole motor. Residual head of 200 kPa approximately. The pumps are controlled in duty/standby, with running hours equalization and changeover on device failure. Specifications and characteristic curves are available in the dedicated bulletin section.	The hydronic module includes the pumps and the main water circuit components, thus optimizing hydraulic and electrical installation space, time and costs.	ALL
4860 EV - PRIMARY FLOW CONTROL			
4861 EV - CONSTANT FLOW	Evaporator water flow control (plant primary circuit): constant flow. Compatible with hydronic modules without regulation devices (no pumps, no contacts), with ON/OFF regulation devices (relays) or with fixed speed pumps (codes: 4701, 4702, 4703, 4704, 4705, 4706, 4707, 4708, 4709, 4711, 4712 - hydronic modules availability depends on unit model).	The unit is set up to operate with a constant water flow in the heat exchanger (plant primary circuit). This is the only option available in case of unit without any water flow regulation devices (no pumps, no contacts), which means with water flow control provided by others. In case of unit with ON/FF regulation devices or fixed speed pumps, the unit controller manages the pump activation to reduce pump consumption.	ALL
4862 EV - CONSTANT FLOW (PARAMETER)	Evaporator water flow control (plant primary circuit): constant flow (parameter set). Compatible with hydronic modules with modulating regulation devices (0-10V signal) or with variable speed pumps (codes: 4713, 4714, 4715, 4716, 4717, 4718, 4719, 4721, 4722, 4723 - hydronic modules availability depends on unit model).	The unit is set up to operate with a constant water flow in the heat exchanger (plant primary circuit). The unit controller manages the pump activation to reduce pump consumption. The pump speed is adjusted via 0-10V signal. The option provides the possibility to set the pump speed with a controller parameter. Once set, the speed pump remains constant until the next parameter adjustment. The parameter set constant flow control is useful during the unit installation and commissioning, to adjust water flow and pressure head according to the real plant characteristics.	ALL

OPTIONS

OPTIONS	DESCRIPTIONS	BENEFITS	AVAILABLE FOR MODELS
4864 EV - VPF (plant DP trans excl)	<p>Evaporator water flow control (plant primary circuit): variable flow (delta P control). Only for single unit systems.</p> <p>Compatible with hydronic modules with modulating regulation devices (0-10V signal) or with variable speed pumps (codes: 4713, 4714, 4715, 4716, 4717, 4718, 4719, 4721, 4722, 4723 - hydronic modules availability depends on unit model).</p> <p>The option includes: differential pressure transducer on the unit's heat exchanger and related controller expansion board, controller expansion board to read the plant side differential pressure transducer (4-20mA signal) and manage the hydraulic by-pass valve opening (0-10V signal). Compulsory equipment, supplied by others: plant side differential pressure transducer, plant side hydraulic by-pass valve.</p>	<p>The unit is set up to operate with a variable water flow in the heat exchanger (plant primary circuit).</p> <p>The unit controller manages the pump activation to reduce pump consumption. The pump speed is adjusted via 0-10V signal.</p> <p>The option provides a pump speed management based on the VPF (Variable Primary Flow) function. It keeps the delta P constant on the plant side (primary circuit), thus bringing significant pump consumption reduction during part load operation.</p> <p>The VPF function is applicable in systems with only the primary circuit.</p> <p>Further information available in the dedicated bulletin section.</p>	ALL
4865 EV - VPF (plant DP trans incl)	<p>Evaporator water flow control (plant primary circuit): variable flow (delta P control). Only for single unit systems.</p> <p>Compatible with hydronic modules with modulating regulation devices (0-10V signal) or with variable speed pumps (codes: 4713, 4714, 4715, 4716, 4717, 4718, 4719, 4721, 4722, 4723 - hydronic modules availability depends on unit model).</p> <p>The option includes: differential pressure transducer on the unit's heat exchanger and related controller expansion board, plant side differential pressure transducer (installation by others), controller expansion board to read the plant side differential pressure transducer (4-20mA signal) and manage the hydraulic by-pass valve opening (0-10V signal). Compulsory equipment, supplied by others: plant side hydraulic by-pass valve.</p>	<p>The unit is set up to operate with a variable water flow in the heat exchanger (plant primary circuit).</p> <p>The unit controller manages the pump activation to reduce pump consumption. The pump speed is adjusted via 0-10V signal.</p> <p>The option provides a pump speed management based on the VPF (Variable Primary Flow) function. It keeps the delta P constant on the plant side (primary circuit), thus bringing significant pump consumption reduction during part load operation.</p> <p>The VPF function is applicable in systems with only the primary circuit.</p> <p>Further information available in the dedicated bulletin section.</p>	ALL
4866 EV - VPF MULTI-UNIT SYSTEM	<p>Evaporator water flow control (plant primary circuit): variable flow (delta P control). Only for multi-unit systems.</p> <p>Compatible with hydronic modules with modulating regulation devices (0-10V signal) or with variable speed pumps (codes: 4713, 4714, 4715, 4716, 4717, 4718, 4719, 4721, 4722, 4723 - hydronic modules availability depends on unit model).</p> <p>The option includes: differential pressure transducer on the unit's heat exchanger and related controller expansion board.</p> <p>It shall be the customer responsibility to configure the multi-unit control system (Manager3000 or ClimaPRO) with option VPF.</p>	<p>The unit is set up to operate with a variable water flow in the heat exchanger (plant primary circuit).</p> <p>The unit controller manages the pump activation to reduce pump consumption. The pump speed is adjusted via 0-10V signal.</p> <p>The option provides a pump speed management based on the VPF (Variable Primary Flow) function. It keeps the delta P constant on the plant side (primary circuit), thus bringing significant pump consumption reduction during part load operation.</p> <p>The VPF function is applicable in systems with only the primary circuit.</p> <p>Further information available in the dedicated bulletin section.</p>	ALL

OPTIONS

OPTIONS	DESCRIPTIONS	BENEFITS	AVAILABLE FOR MODELS
4867 EV - VPF.D	Evaporator water flow control (plant primary circuit): variable flow (delta T control). Only for single unit systems. Compatible with hydronic modules with modulating regulation devices (0-10V signal) or with variable speed pumps (codes: 4713, 4714, 4715, 4716, 4717, 4718, 4719, 4721, 4722, 4723 - hydronic modules availability depends on unit model). The option includes: 2 plant side NTC temperature sensors (installation by others).	The unit is set up to operate with a variable water flow in the heat exchanger (plant primary circuit). The unit controller manages the pump activation to reduce pump consumption. The pump speed is adjusted via 0-10V signal. The option provides a pump speed management based on the VPF.D (Variable Primary Flow with Decoupler) function. It keeps the delta T constant on the plant side (primary circuit), thus bringing significant pump consumption reduction during part load operation. The VPF.D function is applicable in systems with the primary and secondary circuits separated by a hydraulic decoupler. Further information available in the dedicated bulletin section.	ALL
4868 EV - VPF.D MULTI-UNIT SYSTEM	Evaporator water flow control (plant primary circuit): variable flow (delta T control). Only for multi-unit systems. Compatible with hydronic modules with modulating regulation devices (0-10V signal) or with variable speed pumps (codes: 4713, 4714, 4715, 4716, 4717, 4718, 4719, 4721, 4722, 4723 - hydronic modules availability depends on unit model). It shall be the customer responsibility to configure the multi-unit control system (Manager3000 or ClimaPRO) with option VPF.D.	The unit is set up to operate with a variable water flow in the heat exchanger (plant primary circuit). The unit controller manages the pump activation to reduce pump consumption. The pump speed is adjusted via 0-10V signal. The option provides a pump speed management based on the VPF.D (Variable Primary Flow with Decoupler) function. It keeps the delta T constant on the plant side (primary circuit), thus bringing significant pump consumption reduction during part load operation. The VPF.D function is applicable in systems with the primary and secondary circuits separated by a hydraulic decoupler. Further information available in the dedicated bulletin section.	ALL
4869 EV - VPF.E	Evaporator water flow control (plant primary circuit): variable flow (delta T control). Compatible with hydronic modules with modulating regulation devices (0-10V signal) or with variable speed pumps (codes: 4713, 4714, 4715, 4716, 4717, 4718, 4719, 4721, 4722, 4723 - hydronic modules availability depends on unit model).	The unit is set up to operate with a variable water flow in the heat exchanger (plant primary circuit). The unit controller manages the pump activation to reduce pump consumption. The pump speed is adjusted via 0-10V signal. The option provides a pump speed management based on the VPF.E function. It keeps the delta T constant on the plant side (primary circuit), thus bringing significant pump consumption reduction during part load operation. The VPF.E function is applicable in systems with only the primary circuit and with the hydraulic terminals equipped 3 way valve (by-pass). Further information available in the dedicated bulletin section.	ALL
4760 CD - HYDRONIC MODULE			
4762 CD - RELAY 1 PUMP (ON/OFF)	Condenser hydronic module, compatible with constant flow control. The unit is provided with 1 relay to control the activation of 1 external pump via single ON/OFF signal.	The hydronic module allows to control the external pumps with the unit controller logic.	ALL

OPTIONS

OPTIONS	DESCRIPTIONS	BENEFITS	AVAILABLE FOR MODELS
4763 CD - RELAY 2 PUMPS (ON/OFF)	Condenser hydronic module, compatible with constant flow control. The unit is provided with 2 relays to control the activation of 2 external pumps via double ON/OFF signal. The pumps are controlled in duty/standby, with running hours equalization and changeover on device failure.	The hydronic module allows to control the external pumps with the unit controller logic.	ALL
4764 CD - 1 PUMP 4P LH (FIX SPEED)	Condenser hydronic module, compatible with constant flow control. The unit is provided with 1 fixed speed pump, with 4-pole motor. Residual head of 100 kPa approximately. Specifications and characteristic curves are available in the dedicated bulletin section.	The hydronic module includes the pumps and the main water circuit components, thus optimizing hydraulic and electrical installation space, time and costs.	ALL
4766 CD - 1 PUMP 2P LH (FIX SPEED)	Condenser hydronic module, compatible with constant flow control. The unit is provided with 1 fixed speed pump, with 2-pole motor. Residual head of 100 kPa approximately. Specifications and characteristic curves are available in the dedicated bulletin section.	The hydronic module includes the pumps and the main water circuit components, thus optimizing hydraulic and electrical installation space, time and costs.	ALL
4767 CD - 1 PUMP 2P HH (FIX SPEED)	Condenser hydronic module, compatible with constant flow control. The unit is provided with 1 fixed speed pump, with 2-pole motor. Residual head of 200 kPa approximately. Specifications and characteristic curves are available in the dedicated bulletin section.	The hydronic module includes the pumps and the main water circuit components, thus optimizing hydraulic and electrical installation space, time and costs.	ALL
4768 CD - 2 PUMPS 4P LH (FIX SPEED)	Condenser hydronic module, compatible with constant flow control. The unit is provided with 2 fixed speed pumps, with 4-pole motor. Residual head of 100 kPa approximately. The pumps are controlled in duty/standby, with running hours equalization and changeover on device failure. Specifications and characteristic curves are available in the dedicated bulletin section.	The hydronic module includes the pumps and the main water circuit components, thus optimizing hydraulic and electrical installation space, time and costs.	ALL
4771 CD - 2 PUMPS 2P LH (FIX SPEED)	Condenser hydronic module, compatible with constant flow control. The unit is provided with 2 fixed speed pumps, with 2-pole motor. Residual head of 100 kPa approximately. The pumps are controlled in duty/standby, with running hours equalization and changeover on device failure. Specifications and characteristic curves are available in the dedicated bulletin section.	The hydronic module includes the pumps and the main water circuit components, thus optimizing hydraulic and electrical installation space, time and costs.	ALL
4772 CD - 2 PUMPS 2P HH (FIX SPEED)	Condenser hydronic module, compatible with constant flow control. The unit is provided with 2 fixed speed pumps, with 2-pole motor. Residual head of 200 kPa approximately. The pumps are controlled in duty/standby, with running hours equalization and changeover on device failure. Specifications and characteristic curves are available in the dedicated bulletin section.	The hydronic module includes the pumps and the main water circuit components, thus optimizing hydraulic and electrical installation space, time and costs.	ALL

OPTIONS

OPTIONS	DESCRIPTIONS	BENEFITS	AVAILABLE FOR MODELS
4773 CD - RELAY 1 PUMP + 0-10V SIG	Condenser hydronic module, compatible with constant or variable flow control. The unit is provided with 1 relay and a 0-10V signal terminal to control the activation and the speed of 1 external variable speed pump.	The hydronic module allows to control the external pumps with the unit controller logic. In case of water cooled chiller, the 0-10V signal, it allows to manage several condensing devices in order to maintain the condensing pressure in a pre-defined range in every applications: - for well water application to manage a 2 way modulating valve; - for cooling tower application to manage a 3 way modulation valve; - for dry-cooler or cooling tower application to modulate the fans' speed.	ALL
4774 CD - RELAY 2 PUMPS + 0-10V SIG	Condenser hydronic module, compatible with constant or variable flow control. The unit is provided with 2 relays and a 0-10V signal terminal to control the activation and the speed of 2 external variable speed pump. The pumps are controlled in duty/standby, with running hours equalization and changeover on device failure.	The hydronic module allows to control the external pumps with the unit controller logic. In case of water cooled chiller, the 0-10V signal, it allows to manage several condensing devices in order to maintain the condensing pressure in a pre-defined range in every applications: - for well water application to manage a 2 way modulating valve; - for cooling tower application to manage a 3 way modulation valve; - for dry-cooler or cooling tower application to modulate the fans' speed.	ALL
4777 CD - 1 PUMP 2P LH (VAR SPEED)	Condenser hydronic module, compatible with constant or variable flow control. The unit is provided with 1 variable speed pump, with 2-pole motor. Residual head of 100 kPa approximately. Specifications and characteristic curves are available in the dedicated bulletin section.	The hydronic module includes the pumps and the main water circuit components, thus optimizing hydraulic and electrical installation space, time and costs.	ALL
4778 CD - 1 PUMP 2P HH (VAR SPEED)	Condenser hydronic module, compatible with constant or variable flow control. The unit is provided with 1 variable speed pump, with 2-pole motor. Residual head of 200 kPa approximately. Specifications and characteristic curves are available in the dedicated bulletin section.	The hydronic module includes the pumps and the main water circuit components, thus optimizing hydraulic and electrical installation space, time and costs.	ALL
4782 CD - 2 PUMPS 2P LH (VAR SPEED)	Condenser hydronic module, compatible with constant or variable flow control. The unit is provided with 2 variable speed pumps, with 2-pole motor. Residual head of 100 kPa approximately. The pumps are controlled in duty/standby, with running hours equalization and changeover on device failure. Specifications and characteristic curves are available in the dedicated bulletin section.	The hydronic module includes the pumps and the main water circuit components, thus optimizing hydraulic and electrical installation space, time and costs.	ALL
4783 CD - 2 PUMPS 2P HH (VAR SPEED)	Condenser hydronic module, compatible with constant or variable flow control. The unit is provided with 2 variable speed pumps, with 2-pole motor. Residual head of 200 kPa approximately. The pumps are controlled in duty/standby, with running hours equalization and changeover on device failure. Specifications and characteristic curves are available in the dedicated bulletin section.	The hydronic module includes the pumps and the main water circuit components, thus optimizing hydraulic and electrical installation space, time and costs.	ALL

OPTIONS

OPTIONS	DESCRIPTIONS	BENEFITS	AVAILABLE FOR MODELS
4890 CD - PRIMARY FLOW CONTROL			
4891 CD - CONSTANT FLOW	Condenser water flow control (plant primary circuit): constant flow. Compatible with hydronic modules without regulation devices (no pumps, no contacts), with ON/OFF regulation devices (relays) or with fixed speed pumps (codes: 4701, 4702, 4703, 4704, 4705, 4706, 4707, 4708, 4709, 4711, 4712 - hydronic modules availability depends on unit model).	The unit is set up to operate with a constant water flow in the heat exchanger (plant primary circuit). This is the only option available in case of unit without any water flow regulation devices (no pumps, no contacts), which means with water flow control provided by others. In case of unit with ON/FF regulation devices or fixed speed pumps, the unit controller manages the pump activation to reduce pump consumption.	ALL
4892 CD - CONSTANT FLOW (PARAMETER)	Condenser water flow control (plant primary circuit): constant flow (parameter set). Compatible with hydronic modules with modulating regulation devices (0-10V signal) or with variable speed pumps (codes: 4713, 4714, 4715, 4716, 4717, 4718, 4719, 4721, 4722, 4723 - hydronic modules availability depends on unit model).	The unit is set up to operate with a constant water flow in the heat exchanger (plant primary circuit). The unit controller manages the pump activation to reduce pump consumption. The pump speed is adjusted via 0-10V signal. The option provides the possibility to set the pump speed with a controller parameter. Once set, the speed pump remains constant until the next parameter adjustment. The parameter set constant flow control is useful during the unit installation and commissioning, to adjust water flow and pressure head according to the real plant characteristics.	ALL
4894 CD - VPF (plant DP trans excl)	Condenser water flow control (plant primary circuit): 2 pump speeds. Only for free-cooling units. Compatible with hydronic modules with modulating regulation devices (0-10V signal) or with variable speed pumps (codes: 4713, 4714, 4715, 4716, 4717, 4718, 4719, 4721, 4722, 4723 - hydronic modules availability depends on unit model).	The unit is set up to operate with a variable water flow in the heat exchanger (plant primary circuit). The unit controller manages the pump activation to reduce pump consumption. The pump speed is adjusted via 0-10V signal. The option provides a pump speed management based on the VPF (Variable Primary Flow) function. It keeps the delta P constant on the plant side (primary circuit), thus bringing significant pump consumption reduction during part load operation. The VPF function is applicable in systems with only the primary circuit. Further information available in the dedicated bulletin section.	ALL
4895 CD - VPF (plant DP trans incl)	Condenser water flow control (plant primary circuit): variable flow (delta P control). Only for single unit systems. Compatible with hydronic modules with modulating regulation devices (0-10V signal) or with variable speed pumps (codes: 4713, 4714, 4715, 4716, 4717, 4718, 4719, 4721, 4722, 4723 - hydronic modules availability depends on unit model). The option includes: differential pressure transducer on the unit's heat exchanger and related controller expansion board, controller expansion board to read the plant side differential pressure transducer (4-20mA signal) and manage the hydraulic by-pass valve opening (0-10V signal). Compulsory equipment, supplied by others: plant side differential pressure transducer, plant side hydraulic by-pass valve.	The unit is set up to operate with a variable water flow in the heat exchanger (plant primary circuit). The unit controller manages the pump activation to reduce pump consumption. The pump speed is adjusted via 0-10V signal. The option provides a pump speed management based on the VPF (Variable Primary Flow) function. It keeps the delta P constant on the plant side (primary circuit), thus bringing significant pump consumption reduction during part load operation. The VPF function is applicable in systems with only the primary circuit. Further information available in the dedicated bulletin section.	ALL

OPTIONS

OPTIONS	DESCRIPTIONS	BENEFITS	AVAILABLE FOR MODELS
4896 CD - VPF MULTI-UNIT SYSTEM	<p>Condenser water flow control (plant primary circuit): variable flow (delta P control). Only for single unit systems.</p> <p>Compatible with hydronic modules with modulating regulation devices (0-10V signal) or with variable speed pumps (codes: 4713, 4714, 4715, 4716, 4717, 4718, 4719, 4721, 4722, 4723 - hydronic modules availability depends on unit model).</p> <p>The option includes: differential pressure transducer on the unit's heat exchanger and related controller expansion board, plant side differential pressure transducer (installation by others), controller expansion board to read the plant side differential pressure transducer (4-20mA signal) and manage the hydraulic by-pass valve opening (0-10V signal).</p> <p>Compulsory equipment, supplied by others: plant side hydraulic by-pass valve.</p>	<p>The unit is set up to operate with a variable water flow in the heat exchanger (plant primary circuit).</p> <p>The unit controller manages the pump activation to reduce pump consumption. The pump speed is adjusted via 0-10V signal.</p> <p>The option provides a pump speed management based on the VPF (Variable Primary Flow) function. It keeps the delta P constant on the plant side (primary circuit), thus bringing significant pump consumption reduction during part load operation.</p> <p>The VPF function is applicable in systems with only the primary circuit.</p> <p>Further information available in the dedicated bulletin section.</p>	ALL
4897 CD - VPF.D	<p>Condenser water flow control (plant primary circuit): variable flow (delta P control). Only for multi-unit systems.</p> <p>Compatible with hydronic modules with modulating regulation devices (0-10V signal) or with variable speed pumps (codes: 4713, 4714, 4715, 4716, 4717, 4718, 4719, 4721, 4722, 4723 - hydronic modules availability depends on unit model).</p> <p>The option includes: differential pressure transducer on the unit's heat exchanger and related controller expansion board.</p> <p>It shall be the customer responsibility to configure the multi-unit control system (Manager3000 or ClimaPRO) with option VPF.</p>	<p>The unit is set up to operate with a variable water flow in the heat exchanger (plant primary circuit).</p> <p>The unit controller manages the pump activation to reduce pump consumption. The pump speed is adjusted via 0-10V signal.</p> <p>The option provides a pump speed management based on the VPF.D (Variable Primary Flow with Decoupler) function. It keeps the delta T constant on the plant side (primary circuit), thus bringing significant pump consumption reduction during part load operation.</p> <p>The VPF.D function is applicable in systems with the primary and secondary circuits separated by a hydraulic decoupler.</p> <p>Further information available in the dedicated bulletin section.</p>	ALL
4898 CD - VPF.D MULTI-UNIT SYSTEM	<p>Condenser water flow control (plant primary circuit): variable flow (delta T control). Only for single unit systems.</p> <p>Compatible with hydronic modules with modulating regulation devices (0-10V signal) or with variable speed pumps (codes: 4713, 4714, 4715, 4716, 4717, 4718, 4719, 4721, 4722, 4723 - hydronic modules availability depends on unit model).</p> <p>The option includes: 2 plant side NTC temperature sensors (installation by others).</p>	<p>The unit is set up to operate with a variable water flow in the heat exchanger (plant primary circuit).</p> <p>The unit controller manages the pump activation to reduce pump consumption. The pump speed is adjusted via 0-10V signal.</p> <p>The option provides a pump speed management based on the VPF.D (Variable Primary Flow with Decoupler) function. It keeps the delta T constant on the plant side (primary circuit), thus bringing significant pump consumption reduction during part load operation.</p> <p>The VPF.D function is applicable in systems with the primary and secondary circuits separated by a hydraulic decoupler.</p> <p>Further information available in the dedicated bulletin section.</p>	ALL

OPTIONS

OPTIONS	DESCRIPTIONS	BENEFITS	AVAILABLE FOR MODELS
4899 CD - VPF.E	<p>Condenser water flow control (plant primary circuit): variable flow (delta T control). Only for multi-unit systems.</p> <p>Compatible with hydronic modules with modulating regulation devices (0-10V signal) or with variable speed pumps (codes: 4713, 4714, 4715, 4716, 4717, 4718, 4719, 4721, 4722, 4723 - hydronic modules availability depends on unit model).</p> <p>It shall be the customer responsibility to configure the multi-unit control system (Manager3000 or ClimaPRO) with option VPF.D.</p>	<p>The unit is set up to operate with a variable water flow in the heat exchanger (plant primary circuit).</p> <p>The unit controller manages the pump activation to reduce pump consumption. The pump speed is adjusted via 0-10V signal.</p> <p>The option provides a pump speed management based on the VPF.E function. It keeps the delta T constant on the plant side (primary circuit), thus bringing significant pump consumption reduction during part load operation.</p> <p>The VPF.E function is applicable in systems with only the primary circuit and with the hydraulic terminals equipped 3 way valve (by-pass).</p> <p>Further information available in the dedicated bulletin section.</p>	ALL
5940 SETP. COMPENSATION OUT. TEMP.			
5941 WITH SETPOINT COMPENSATION	<p>This option includes an outside air sensor to be installed outside the building and enable the climatic curve function.</p>	<p>Available as option an outside air temperature probe to control the system water temperature set point based on cooling and heating (reversible units) climatic curves. Delivering water at different temperatures to the terminals based on the outside air temperature achieves high seasonal efficiency ratios and brings considerable savings in running costs.</p>	ALL
2620 ACOUSTICAL ENCLOSURE			
2621 EXTRA SOUNDPROOFING INSULATION	<p>Increased soundproofing enclosure for compressor section</p>	Noise emission reduction	ALL
9970 PACKING			
9968 NYLON, SUPP., COIL PROT. PACK.	<p>Unit provided plastic supports, with polypropylene panels for coils protection and covered with nylon</p>		ALL
9972 WOODEN BOX PACKING	<p>Unit provided with wooden box</p>		ALL
9973 WOODEN CAGE PACKING	<p>Unit provided with wooden cage</p>		ALL
9977 SUPPORTS + COILS PROTECTION	<p>Unit provided plastic supports and covered with nylon</p>		ALL

OPTIONS

Additional information - IMPORTANT -

3301 – Compressor power factor correction

1511 – Soft starter

There is a mutual exclusion rule between the compressor rephrasing condensers and the soft start device. When both accessories are required together, a feasibility analysis is needed. If the configuration is available as a special execution, an extra-price may be quoted.

808 - EC fans

These fans are suitable to operate up to 46°C of outdoor temperature.

In case of higher temperatures, fans with oversized motors must be used. For the quotation of these components, please contact our sales department.

3412 – Automatic circuit breakers

4706, 4707, 4711, 4712, 4766, 4767, 4771, 4772 – Pumps on board

Fixed speed pumps are available on board only when the unit is provided with automatic circuit breakers.

OPTIONS

Chiller Plant Control with Active Optimization System

ClimaPRO System Manager

ClimaPRO System Manager represents the state-of-the-art platform for chiller plant management and control.

ClimaPRO ensures to actively optimize the entire chiller plant by managing and adjusting each component directly involved in the production and the distribution of the heating and the cooling energies, therefore involving chillers and heat pumps, pumping groups as well as the source-side devices like, for example, the cooling towers.

In particular, ClimaPRO measures in real-time all the operating variables from the field, for each individual device and each of the main system branches, by using serial communication lines as well as dedicated analogue signals.

The acquired data are then compared with the design data of each single unit at any different working conditions, thus allowing to implement control strategies based on dynamic algorithms which take into account the real operating conditions.

On the basis of these values, an advanced diagnostic module also allows to assess the level of efficiency for each individual unit, translating data into easy-to-read information in order to simplify and optimize the maintenance activities.

The "Chart Builder" software module allows to display the trends of the main operating variables. The "Reporting" module allows to send reports to selected users, including data and system's status of the main devices as well as to perform calculation of the energy indexes for each single unit and for the entire chiller plant.

The accessibility to ClimaPRO System Manager is ensured by an integrated web server that makes it visible from any computer equipped with a web browser, either locally or remotely.



6.1 GENERAL TECHNICAL DATA

NX-Q-G06

[SI System]

NX-Q-G06		0604	0704	0804	0904	1004	1104	1204	
Power supply		V/ph/Hz 400/3/50 400/3/50 400/3/50 400/3/50 400/3/50 400/3/50 400/3/50							
PERFORMANCE									
COOLING ONLY (GROSS VALUE)									
Cooling capacity	(1)	kW	143,9	159,6	181,2	202,6	230,4	266,0	298,3
Total power input	(1)	kW	54,98	64,32	70,66	79,45	89,22	100,2	112,3
EER	(1)	kW/kW	2,616	2,482	2,563	2,548	2,583	2,655	2,656
ESEER	(1)	kW/kW							
COOLING ONLY (EN14511 VALUE)									
Cooling capacity	(1)(2)	kW	143,5	159,3	180,9	202,3	230,1	265,6	298,0
EER	(1)(2)	kW/kW	2,580	2,450	2,530	2,520	2,550	2,620	2,630
ESEER	(1)(2)	kW/kW	-	-	-	-	-	-	-
HEATING ONLY (GROSS VALUE)									
Total heating capacity	(3)	kW	157,2	174,3	196,8	220,1	250,5	288,0	323,3
Total power input	(3)	kW	53,16	59,45	66,00	72,97	84,23	95,24	106,4
COP	(3)	kW/kW	2,955	2,934	2,982	3,015	2,975	3,025	3,039
HEATING ONLY (EN14511 VALUE)									
Total heating capacity	(2)(3)	kW	157,5	174,6	197,1	220,5	250,9	288,4	323,7
COP	(2)(3)	kW/kW	2,920	2,900	2,940	2,980	2,940	2,990	3,000
COOLING WITH HEAT RECOVERY (EN 14511 VALUE)									
Cooling capacity	(2)(4)	kW	144,6	165,6	186,1	210,9	235,9	269,0	303,7
Total power input	(2)(4)	kW	47,72	54,57	61,63	68,87	76,32	88,71	99,91
Recovery heat exchanger capacity	(2)(4)	kW	188,8	216,0	243,1	274,6	306,3	350,8	395,9
TER		kW/kW	6,987	6,993	6,963	7,049	7,105	6,987	7,003
EXCHANGERS									
HEAT EXCHANGER USER SIDE IN REFRIGERATION									
Water flow	(1)	l/s	6,880	7,631	8,667	9,689	11,02	12,72	14,27
Pressure drop at the heat exchanger	(1)	kPa	38,6	39,6	40,3	39,4	40,9	43,6	43,5
HEAT EXCHANGER USER SIDE IN HEATING									
Water flow	(3)	l/s	7,589	8,413	9,498	10,63	12,09	13,90	15,60
Pressure drop at the heat exchanger	(3)	kPa	50,3	52,3	54,3	54,7	58,7	58,1	59,6
REFRIGERANT CIRCUIT									
Compressors nr.		N°	4	4	4	4	4	4	4
Number of capacity steps		N°	4	4	4	4	4	4	4
No. Circuits		N°	2	2	2	2	2	2	2
Regulation			STEPS	STEPS	STEPS	STEPS	STEPS	STEPS	STEPS
Min. capacity step		%	25	25	25	25	25	25	25
Refrigerant			R454B	R454B	R454B	R454B	R454B	R454B	R454B
Refrigerant charge		kg	38,3	38,4	54,2	57,3	60,5	72,5	97,2
Oil charge		kg	10,8	10,8	10,8	16,0	21,2	21,2	21,2
Rc (ASHRAE)	(5)	kg/kW	0,27	0,24	0,30	0,29	0,27	0,28	0,33
NOISE LEVEL									
Sound Pressure	(6)	dB(A)	60	60	60	61	62	63	63
Sound power level in cooling	(7)(8)	dB(A)	92	92	92	93	94	95	95
Sound power level in heating	(7)(9)	dB(A)	92	92	92	93	94	95	95
SIZE AND WEIGHT									
A	(10)	mm	3110	3110	3110	4110	4110	4110	4110
B	(10)	mm	2220	2220	2220	2220	2220	2220	2220
H	(10)	mm	2150	2150	2150	2150	2150	2150	2150
Operating weight	(10)	kg	1660	1730	1850	2130	2370	2540	2680

Notes:

- Plant (side) cooling exchanger water (in/out) 12,00°C/7,00°C; Source (side) heat exchanger air (in) 35,0°C.
 - Values in compliance with EN14511
 - Plant (side) heat exchanger water (in/out) 40,00°C/45,00°C; Source (side) heat exchanger air (in) 7,0°C - 87% R.H.
 - Plant (side) cooling exchanger water (in/out) 12,00°C/7,00°C; Plant (side) heat exchanger water (in/out) 40,00°C/45,00°C.
 - Rated in accordance with AHRI Standard 550/590 (2011 with addendum 1).
 - Average sound pressure level at 10m distance, unit in a free field on a reflective surface; non-binding value calculated from the sound power level.
 - Sound power on the basis of measurements made in compliance with ISO 9614.
 - Sound power level in cooling, outdoors.
 - Sound power level in heating, outdoors.
 - Unit in standard configuration/execution, without optional accessories.
 - Not available
- Certified data in EUROVENT

GENERAL TECHNICAL DATA

NX-Q-G06 /LN

[SI System]

NX-Q-G06 /LN		0604	0704	0804	0904	1004	1104	1204	
Power supply		V/ph/Hz 400/3/50 400/3/50 400/3/50 400/3/50 400/3/50 400/3/50 400/3/50							
PERFORMANCE									
COOLING ONLY (GROSS VALUE)									
Cooling capacity	(1)	kW	137,4	150,8	170,1	191,1	218,2	250,3	279,1
Total power input	(1)	kW	55,04	65,63	73,27	82,00	90,26	103,0	117,1
EER	(1)	kW/kW	2,498	2,299	2,321	2,330	2,416	2,430	2,383
ESEER	(1)	kW/kW							
COOLING ONLY (EN14511 VALUE)									
Cooling capacity	(1)(2)	kW	137,0	150,5	169,7	190,8	217,9	249,9	278,8
EER	(1)(2)	kW/kW	2,470	2,270	2,300	2,310	2,390	2,400	2,360
ESEER	(1)(2)	kW/kW	-	-	-	-	-	-	-
HEATING ONLY (GROSS VALUE)									
Total heating capacity	(3)	kW	149,9	165,5	186,1	211,9	238,3	272,8	304,4
Total power input	(3)	kW	49,58	55,74	62,19	69,31	78,76	89,73	100,8
COP	(3)	kW/kW	3,022	2,971	2,992	3,058	3,024	3,041	3,020
HEATING ONLY (EN14511 VALUE)									
Total heating capacity	(2)(3)	kW	150,2	165,8	186,4	212,2	238,7	273,2	304,9
COP	(2)(3)	kW/kW	2,980	2,940	2,960	3,020	2,990	3,000	2,980
COOLING WITH HEAT RECOVERY (EN 14511 VALUE)									
Cooling capacity	(2)(4)	kW	144,8	165,7	186,3	211,1	236,1	269,3	304,1
Total power input	(2)(4)	kW	47,50	54,31	61,35	68,60	75,96	88,27	99,33
Recovery heat exchanger capacity	(2)(4)	kW	188,8	216,1	243,2	274,6	306,4	351,0	396,1
TER		kW/kW	7,023	7,031	7,000	7,080	7,143	7,027	7,050
EXCHANGERS									
HEAT EXCHANGER USER SIDE IN REFRIGERATION									
Water flow	(1)	l/s	6,568	7,213	8,134	9,141	10,44	11,97	13,35
Pressure drop at the heat exchanger	(1)	kPa	35,2	35,4	35,5	35,1	36,7	38,6	38,1
HEAT EXCHANGER USER SIDE IN HEATING									
Water flow	(3)	l/s	7,238	7,988	8,982	10,23	11,50	13,17	14,70
Pressure drop at the heat exchanger	(3)	kPa	45,8	47,1	48,5	50,7	53,2	52,1	52,9
REFRIGERANT CIRCUIT									
Compressors nr.		N°	4	4	4	4	4	4	4
Number of capacity steps		N°	4	4	4	4	4	4	4
No. Circuits		N°	2	2	2	2	2	2	2
Regulation			STEPS	STEPS	STEPS	STEPS	STEPS	STEPS	STEPS
Min. capacity step		%	25	25	25	25	25	25	25
Refrigerant			R454B	R454B	R454B	R454B	R454B	R454B	R454B
Refrigerant charge		kg	38,3	38,4	54,2	57,3	60,5	72,5	97,2
Oil charge		kg	10,8	10,8	10,8	16,0	21,2	21,2	21,2
Rc (ASHRAE)	(5)	kg/kW	0,28	0,26	0,32	0,30	0,28	0,29	0,35
NOISE LEVEL									
Sound Pressure	(6)	dB(A)	54	54	54	55	56	57	57
Sound power level in cooling	(7)(8)	dB(A)	86	86	86	87	88	89	89
Sound power level in heating	(7)(9)	dB(A)	87	87	87	88	89	90	90
SIZE AND WEIGHT									
A	(10)	mm	3110	3110	3110	4110	4110	4110	4110
B	(10)	mm	2220	2220	2220	2220	2220	2220	2220
H	(10)	mm	2150	2150	2150	2150	2150	2150	2150
Operating weight	(10)	kg	1660	1730	1850	2130	2370	2540	2680

Notes:

- 1 Plant (side) cooling exchanger water (in/out) 12,00°C/7,00°C; Source (side) heat exchanger air (in) 35,0°C.
- 2 Values in compliance with EN14511
- 3 Plant (side) heat exchanger water (in/out) 40,00°C/45,00°C; Source (side) heat exchanger air (in) 7,0°C - 87% R.H.
- 4 Plant (side) cooling exchanger water (in/out) 12,00°C/7,00°C; Plant (side) heat exchanger water (in/out) 40,00°C/45,00°C.
- 5 Rated in accordance with AHRI Standard 550/590 (2011 with addendum 1).
- 6 Average sound pressure level at 10m distance, unit in a free field on a reflective surface; non-binding value calculated from the sound power level.
- 7 Sound power on the basis of measurements made in compliance with ISO 9614.
- 8 Sound power level in cooling, outdoors.
- 9 Sound power level in heating, outdoors.
- 10 Unit in standard configuration/execution, without optional accessories.
- Not available

Certified data in EUROVENT

GENERAL TECHNICAL DATA

NX-Q-G06 /SL

[SI System]

NX-Q-G06 /SL		0604	0704	0804	0904	1004	1104	1204	
Power supply		V/ph/Hz 400/3/50 400/3/50 400/3/50 400/3/50 400/3/50 400/3/50 400/3/50							
PERFORMANCE									
COOLING ONLY (GROSS VALUE)									
Cooling capacity	(1)	kW	136,3	153,3	176,0	192,7	216,3	250,3	282,1
Total power input	(1)	kW	54,37	63,13	70,74	81,80	89,41	101,2	115,5
EER	(1)	kW/kW	2,506	2,429	2,489	2,356	2,419	2,473	2,442
ESEER	(1)	kW/kW							
COOLING ONLY (EN14511 VALUE)									
Cooling capacity	(1)(2)	kW	136,0	153,0	175,7	192,4	216,0	250,0	281,8
EER	(1)(2)	kW/kW	2,480	2,400	2,460	2,330	2,390	2,450	2,420
ESEER	(1)(2)	kW/kW	-	-	-	-	-	-	-
HEATING ONLY (GROSS VALUE)									
Total heating capacity	(3)	kW	149,5	167,3	192,9	212,8	237,7	276,8	310,1
Total power input	(3)	kW	48,36	54,65	63,18	69,95	76,93	88,12	101,1
COP	(3)	kW/kW	3,089	3,064	3,052	3,040	3,091	3,142	3,067
HEATING ONLY (EN14511 VALUE)									
Total heating capacity	(2)(3)	kW	149,8	167,6	193,2	213,1	238,1	277,2	310,6
COP	(2)(3)	kW/kW	3,050	3,030	3,010	3,000	3,050	3,100	3,030
COOLING WITH HEAT RECOVERY (EN 14511 VALUE)									
Cooling capacity	(2)(4)	kW	144,8	165,7	186,2	211,1	236,1	269,2	304,0
Total power input	(2)(4)	kW	47,48	54,37	61,53	68,63	75,93	88,35	99,48
Recovery heat exchanger capacity	(2)(4)	kW	188,8	216,1	243,1	274,6	306,4	350,9	396,0
TER		kW/kW	7,027	7,021	6,978	7,077	7,146	7,019	7,037
EXCHANGERS									
HEAT EXCHANGER USER SIDE IN REFRIGERATION									
Water flow	(1)	l/s	6,518	7,332	8,418	9,216	10,34	11,97	13,49
Pressure drop at the heat exchanger	(1)	kPa	34,6	36,6	38,0	35,7	36,0	38,6	38,9
HEAT EXCHANGER USER SIDE IN HEATING									
Water flow	(3)	l/s	7,214	8,075	9,312	10,27	11,47	13,36	14,97
Pressure drop at the heat exchanger	(3)	kPa	45,5	48,2	52,1	51,1	52,9	53,7	54,9
REFRIGERANT CIRCUIT									
Compressors nr.		N°	4	4	4	4	4	4	4
Number of capacity steps		N°	4	4	4	4	4	4	4
No. Circuits		N°	2	2	2	2	2	2	2
Regulation			STEPS	STEPS	STEPS	STEPS	STEPS	STEPS	STEPS
Min. capacity step		%	25	25	25	25	25	25	25
Refrigerant			R454B	R454B	R454B	R454B	R454B	R454B	R454B
Refrigerant charge		kg	49,5	63,1	63,2	63,3	73,8	99,0	99,0
Oil charge		kg	10,8	10,8	10,8	16,0	21,2	21,2	21,2
Rc (ASHRAE)	(5)	kg/kW	0,37	0,42	0,36	0,33	0,34	0,40	0,35
NOISE LEVEL									
Sound Pressure	(6)	dB(A)	50	50	51	51	51	53	54
Sound power level in cooling	(7)(8)	dB(A)	82	82	83	83	83	85	86
Sound power level in heating	(7)(9)	dB(A)	83	83	84	84	84	86	87
SIZE AND WEIGHT									
A	(10)	mm	3110	3110	4110	4110	4110	5110	5110
B	(10)	mm	2220	2220	2220	2220	2220	2220	2220
H	(10)	mm	2150	2150	2150	2150	2150	2150	2150
Operating weight	(10)	kg	1750	1850	2070	2230	2480	2810	2930

Notes:

- Plant (side) cooling exchanger water (in/out) 12,00°C/7,00°C; Source (side) heat exchanger air (in) 35,0°C.
- Values in compliance with EN14511
- Plant (side) heat exchanger water (in/out) 40,00°C/45,00°C; Source (side) heat exchanger air (in) 7,0°C - 87% R.H.
- Plant (side) cooling exchanger water (in/out) 12,00°C/7,00°C; Plant (side) heat exchanger water (in/out) 40,00°C/45,00°C.
- Rated in accordance with AHRI Standard 550/590 (2011 with addendum 1).
- Average sound pressure level at 10m distance, unit in a free field on a reflective surface; non-binding value calculated from the sound power level.
- Sound power on the basis of measurements made in compliance with ISO 9614.
- Sound power level in cooling, outdoors.
- Sound power level in heating, outdoors.
- Unit in standard configuration/execution, without optional accessories.
- Not available

Certified data in EUROVENT

7.1 TECHNICAL DATA SEASONAL EFFICIENCY IN HEATING (EN14825 VALUE)

NX-Q-G06

[SI System]

NX-Q-G06 - LOW TEMPERATURE application			0604	0704	0804	0904	1004	1104
Power supply		(V/ph/Hz)	400/3/50	400/3/50	400/3/50	400/3/50	400/3/50	400/3/50
WEATHER CONDITIONS - AVERAGE								
Rated heat output at Tdesignh	(1)(2)	kW	120	134	148	163	194	219
Bivalent temperature	(1)(2)	°C	-7	-7	-7	-7	-7	-7
SCOP	(1)(2)		3,53	3,54	3,65	3,49	3,49	3,57
Seasonal space heating energy efficiency	(1)(2)	%	138	139	143	136	137	140
Seasonal space heating energy efficiency class	(1)(2)		-	-	-	-	-	-

1 Seasonal space heating energy efficiency class LOW TEMPERATURE [REGULATION (EU) N. 813/2013]

2 Tipo di calcolo con portata variabile e temperatura variabile.

NX-Q-G06 - LOW TEMPERATURE application			1204
Power supply		(V/ph/Hz)	400/3/50
WEATHER CONDITIONS - AVERAGE			
Rated heat output at Tdesignh	(1)(2)	kW	241
Bivalent temperature	(1)(2)	°C	-7
SCOP	(1)(2)		3,54
Seasonal space heating energy efficiency	(1)(2)	%	139
Seasonal space heating energy efficiency class	(1)(2)		-

1 Seasonal space heating energy efficiency class LOW TEMPERATURE [REGULATION (EU) N. 813/2013]

2 Tipo di calcolo con portata variabile e temperatura variabile.

**TECHNICAL DATA SEASONAL
EFFICIENCY IN HEATING (EN14825
VALUE)**

NX-Q-G06 /LN

[SI System]

NX-Q-G06 /LN - LOW TEMPERATURE application			0604	0704	0804	0904	1004	1104
Power supply		(V/ph/Hz)	400/3/50	400/3/50	400/3/50	400/3/50	400/3/50	400/3/50
WEATHER CONDITIONS - AVERAGE								
Rated heat output at Tdesignh	(1)(2)	kW	111	121	145	140	176	215
Bivalent temperature	(1)(2)	°C	-7	-7	-7	-7	-7	-7
SCOP	(1)(2)		3,61	3,63	3,71	3,67	3,62	3,78
Seasonal space heating energy efficiency	(1)(2)	%	142	142	146	144	142	148
Seasonal space heating energy efficiency class	(1)(2)		-	-	-	-	-	-

1 Seasonal space heating energy efficiency class LOW TEMPERATURE [REGULATION (EU) N. 813/2013]

2 Tipo di calcolo con portata variabile e temperatura variabile.

NX-Q-G06 /LN - LOW TEMPERATURE application			1204
Power supply		(V/ph/Hz)	400/3/50
WEATHER CONDITIONS - AVERAGE			
Rated heat output at Tdesignh	(1)(2)	kW	240
Bivalent temperature	(1)(2)	°C	-7
SCOP	(1)(2)		3,80
Seasonal space heating energy efficiency	(1)(2)	%	149
Seasonal space heating energy efficiency class	(1)(2)		-

1 Seasonal space heating energy efficiency class LOW TEMPERATURE [REGULATION (EU) N. 813/2013]

2 Tipo di calcolo con portata variabile e temperatura variabile.

**TECHNICAL DATA SEASONAL
EFFICIENCY IN HEATING (EN14825
VALUE)**

NX-Q-G06 /SL

[SI System]

NX-Q-G06 /SL - LOW TEMPERATURE application			0604	0704	0804	0904	1004	1104
Power supply		(V/ph/Hz)	400/3/50	400/3/50	400/3/50	400/3/50	400/3/50	400/3/50
WEATHER CONDITIONS - AVERAGE								
Rated heat output at Tdesignh	(1)(2)	kW	117	133	132	143	188	215
Bivalent temperature	(1)(2)	°C	-7	-7	-7	-7	-7	-7
SCOP	(1)(2)		3,85	3,92	3,62	3,62	3,86	4,00
Seasonal space heating energy efficiency	(1)(2)	%	151	154	142	142	151	157
Seasonal space heating energy efficiency class	(1)(2)		-	-	-	-	-	-

1 Seasonal space heating energy efficiency class LOW TEMPERATURE [REGULATION (EU) N. 813/2013]

2 Tipo di calcolo con portata variabile e temperatura variabile.

NX-Q-G06 /SL - LOW TEMPERATURE application			1204
Power supply		(V/ph/Hz)	400/3/50
WEATHER CONDITIONS - AVERAGE			
Rated heat output at Tdesignh	(1)(2)	kW	242
Bivalent temperature	(1)(2)	°C	-7
SCOP	(1)(2)		3,84
Seasonal space heating energy efficiency	(1)(2)	%	151
Seasonal space heating energy efficiency class	(1)(2)		-

1 Seasonal space heating energy efficiency class LOW TEMPERATURE [REGULATION (EU) N. 813/2013]

2 Tipo di calcolo con portata variabile e temperatura variabile.

8.1 TECHNICAL DATA SEASONAL EFFICIENCY IN COOLING (EN14825 VALUE)

[SI System]

ENERGY EFFICIENCY

SEASONAL EFFICIENCY IN COOLING (Reg. EU 2016/2281)

Ambient refrigeration

NX-Q-G06			0604	0704	0804	0904	1004	1104	1204			
Prated,c	(1)	kW	143,5	159,3	180,9	202,3	230,1	265,6	298,0			
SEER	(1) (2)	-	3,52	3,52	3,67	3,75	3,59	3,75	3,83			
Performance η_s	(1) (3)	%	138,0	138,0	144,0	147,0	140,0	147,0	150,0			

NX-Q-G06 /LN			0604	0704	0804	0904	1004	1104	1204			
Prated,c	(1)	kW	137,0	150,5	169,7	190,8	217,9	249,9	278,8			
SEER	(1) (2)	-	3,59	3,56	3,57	3,70	3,60	3,75	3,72			
Performance η_s	(1) (3)	%	140,0	140,0	140,0	145,0	141,0	147,0	146,0			

NX-Q-G06 /SL			0604	0704	0804	0904	1004	1104	1204			
Prated,c	(1)	kW	136,0	153,0	175,7	192,4	216,0	250,0	281,8			
SEER	(1) (2)	-	3,72	3,79	3,67	3,67	3,73	3,91	3,76			
Performance η_s	(1) (3)	%	146,0	149,0	144,0	144,0	146,0	153,0	148,0			

Notes:

(1) Parameter calculated according to [REGULATION (EU) N. 2016/2281]

(2) Seasonal energy efficiency ratio

(3) Seasonal space cooling energy efficiency

The units highlighted in this publication contain R454B [GWP₁₀₀ 466] fluorinated greenhouse gases.

9.1 OPERATING LIMITS

COOLING

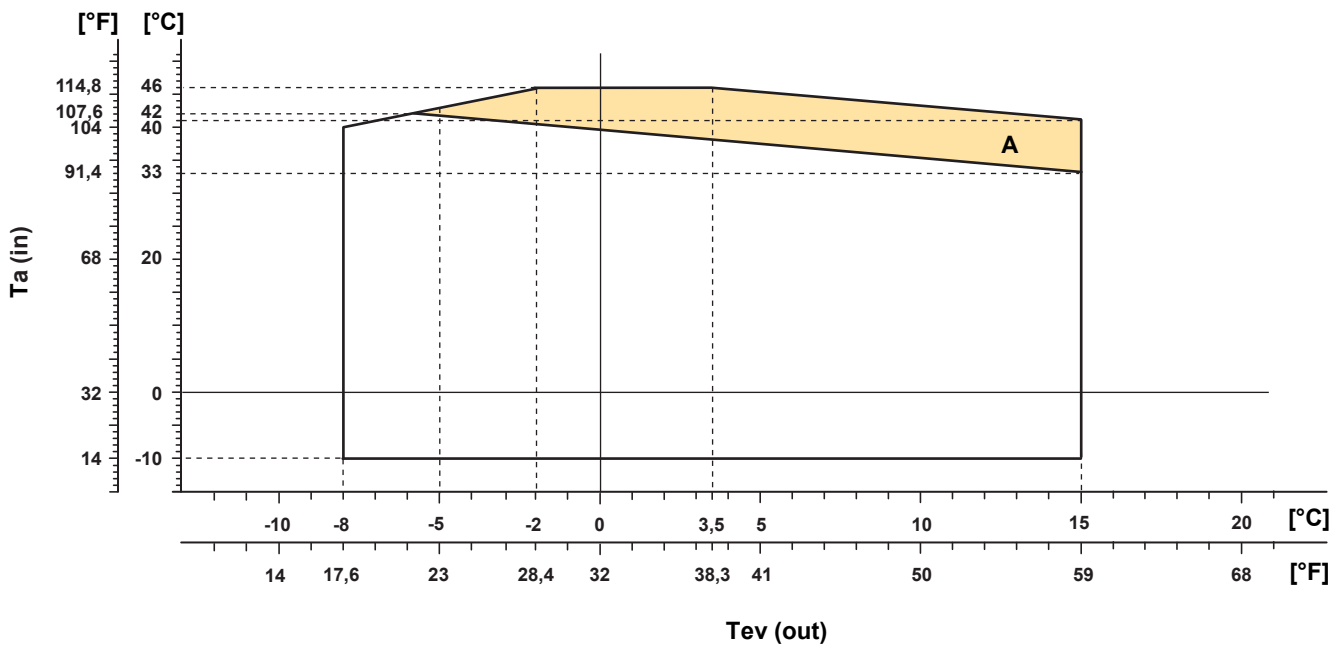

Ta (in) Outdoor air temperature

Tev (out) Plant side cold heat exchanger leaving water temperature

A Not low noise mode

For the specific temperature limits of each model please refer to the selection software ElcaWorld.

OPERATING LIMITS

HEATING

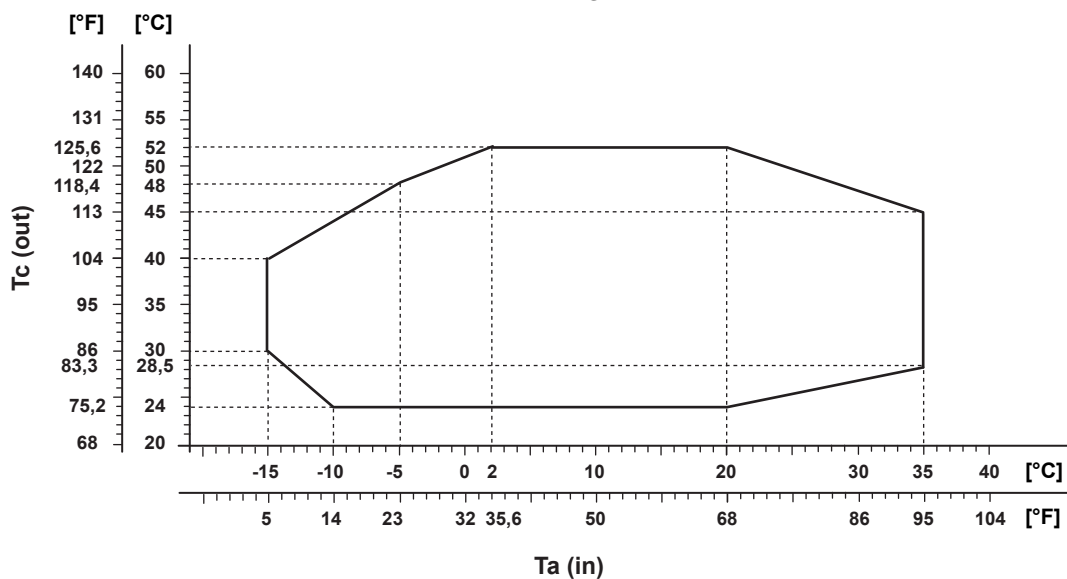

COOLING + RECOVERY

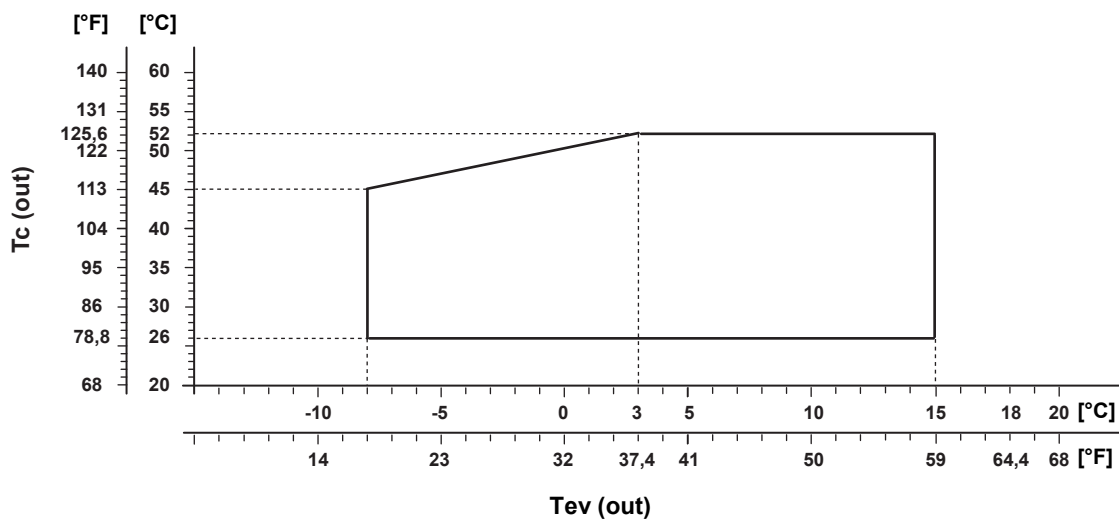

- T_a in Outdoor air temperature
- T_c (out) Plant side hot heat exchanger leaving water temperature
- T_{ev} (out) Plant side cold heat exchanger leaving water temperature

For the specific temperature limits of each model please refer to the selection software ElcaWorld.

OPERATING LIMITS

NX-Q-G06 0604 - 1204

SIZE
NX-Q-G06 0604
NX-Q-G06 0704
NX-Q-G06 0804
NX-Q-G06 0904
NX-Q-G06 1004
NX-Q-G06 1104
NX-Q-G06 1204
NX-Q-G06 /LN 0604
NX-Q-G06 /LN 0704
NX-Q-G06 /LN 0804
NX-Q-G06 /LN 0904
NX-Q-G06 /LN 1004
NX-Q-G06 /LN 1104
NX-Q-G06 /LN 1204
NX-Q-G06 /SL 0604
NX-Q-G06 /SL 0704
NX-Q-G06 /SL 0804
NX-Q-G06 /SL 0904
NX-Q-G06 /SL 1004
NX-Q-G06 /SL 1104
NX-Q-G06 /SL 1204

9.2 ETHYLENE GLYCOL MIXTURE

Ethylene glycol and water mixture, used as a heat-conveying fluid, cause a variation in unit performance. For correct data, use the factors indicated in the following table.

	Freezing point (°C)							
	0	-5	-10	-15	-20	-25	-30	-35
	Ethylene glycol percentage by weight							
	0%	12%	20%	30%	35%	40%	45%	50%
cPf	1	0,985	0,98	0,974	0,97	0,965	0,964	0,96
cQ	1	1,02	1,04	1,075	1,11	1,14	1,17	1,2
cdp	1	1,07	1,11	1,18	1,22	1,24	1,27	1,3

cPf: cooling power correction factor
 cQ: flow correction factor
 cdp: pressure drop correction factor

For data concerning other kind of anti-freeze solutions (e.g. propylene glycol) please contact our Sale Department.

9.3 FOULING FACTORS

Performances are based on clean condition of tubes (fouling factor = 1). For different fouling values, performance should be adjusted using the correction factors shown in the following table.

SERIES	FOULING FACTORS	EVAPORATOR			CONDENSER/RECOVERY			DESUPERHEATER
	ff (m ² °CW)	F1	FK1	KE [°C]	F2	FK2	KC [°C]	R3
VARIOUS	0	1,000	1,000	0,0	1,000	1,000	0,0	1,000
VARIOUS	1,80 x 10 ⁻⁵	1,000	1,000	0,0	1,000	1,000	0,0	1,000
VARIOUS	4,40 x 10 ⁻⁵	1,000	1,000	0,0	0,990	1,030	1,0	0,990
VARIOUS	8,80 x 10 ⁻⁵	0,960	0,990	0,7	0,980	1,040	1,5	0,980
VARIOUS	13,20 x 10 ⁻⁵	0,944	0,985	1,0	0,964	1,050	2,3	0,964
VARIOUS	17,20 x 10 ⁻⁵	0,930	0,980	1,5	0,950	1,060	3,0	0,950

ff: fouling factors
 F1 - F2: potential correction factors
 FK1 - FK2: compressor power input correction factors
 R3: capacity correction factors
 KE: minimum evaporator outlet temperature increase
 KC: maximum condenser outlet temperature decrease

10.1 HYDRAULIC DATA

[SI System]

Water flow and pressure drop

Water flow in the plant (side) exchanger is given by:

$$Q = P / (4,186 \times Dt)$$

Q: water flow (l/s)

Dt: difference between inlet and outlet water temp. (°C)

P: heat exchanger capacity (kW)

Pressure drop is given by:

$$Dp = K \times (3,6 \times Q)^2 / 1000$$

Q: water flow (l/s)

Dp: pressure drop (kPa)

K: unit size ratio

SIZE	Power supply V/ph/Hz	CHILLED WATER HEAT EX. USER SIDE					WARM WATER HEAT EX. USER SIDE			
		K	Q min l/s	Q max l/s	C.A.S. l	C.a. min l	K [1]	Q min [2] l/s	Q max l/s	C.A.S. l
NX-Q-G06 0604	400/3/50	62,9	4,444	11,97	-	1100	67,4	4,444	11,97	-
NX-Q-G06 0704	400/3/50	52,5	4,917	13,25	-	1200	57,0	4,917	13,25	-
NX-Q-G06 0804	400/3/50	41,4	5,611	15,08	-	1400	46,4	5,611	15,08	-
NX-Q-G06 0904	400/3/50	32,4	6,278	16,83	-	1500	37,4	6,278	16,83	-
NX-Q-G06 1004	400/3/50	26,0	7,139	17,22	-	1700	31,0	7,139	17,22	-
NX-Q-G06 1104	400/3/50	20,8	8,250	21,11	-	2000	23,2	8,250	21,11	-
NX-Q-G06 1204	400/3/50	16,5	9,250	21,11	-	2200	18,9	9,250	21,11	-
NX-Q-G06 /LN 0604	400/3/50	62,9	4,444	11,97	-	1100	67,4	4,444	11,97	-
NX-Q-G06 /LN 0704	400/3/50	52,5	4,917	13,25	-	1200	57,0	4,917	13,25	-
NX-Q-G06 /LN 0804	400/3/50	41,4	5,611	15,08	-	1400	46,4	5,611	15,08	-
NX-Q-G06 /LN 0904	400/3/50	32,4	6,278	16,83	-	1500	37,4	6,278	16,83	-
NX-Q-G06 /LN 1004	400/3/50	26,0	7,139	17,22	-	1700	31,0	7,139	17,22	-
NX-Q-G06 /LN 1104	400/3/50	20,8	8,250	21,11	-	2000	23,2	8,250	21,11	-
NX-Q-G06 /LN 1204	400/3/50	16,5	9,250	21,11	-	2200	18,9	9,250	21,11	-
NX-Q-G06 /SL 0604	400/3/50	62,9	4,444	11,97	-	1100	67,4	4,444	11,97	-
NX-Q-G06 /SL 0704	400/3/50	52,5	4,917	13,25	-	1200	57,0	4,917	13,25	-
NX-Q-G06 /SL 0804	400/3/50	41,4	5,611	15,08	-	1400	46,4	5,611	15,08	-
NX-Q-G06 /SL 0904	400/3/50	32,4	6,278	16,83	-	1500	37,4	6,278	16,83	-
NX-Q-G06 /SL 1004	400/3/50	26,0	7,139	17,22	-	1700	31,0	7,139	17,22	-
NX-Q-G06 /SL 1104	400/3/50	20,8	8,250	21,11	-	2000	23,2	8,250	21,11	-
NX-Q-G06 /SL 1204	400/3/50	16,5	9,250	21,11	-	2200	18,9	9,250	21,11	-

Q min: minimum water flow admitted to the heat exchanger
 Q max: maximum water flow admitted to the heat exchanger
 C.a. min: minimum water content admitted in the plant
 C.A.S.: Exchanger water content

HYDRAULIC DATA

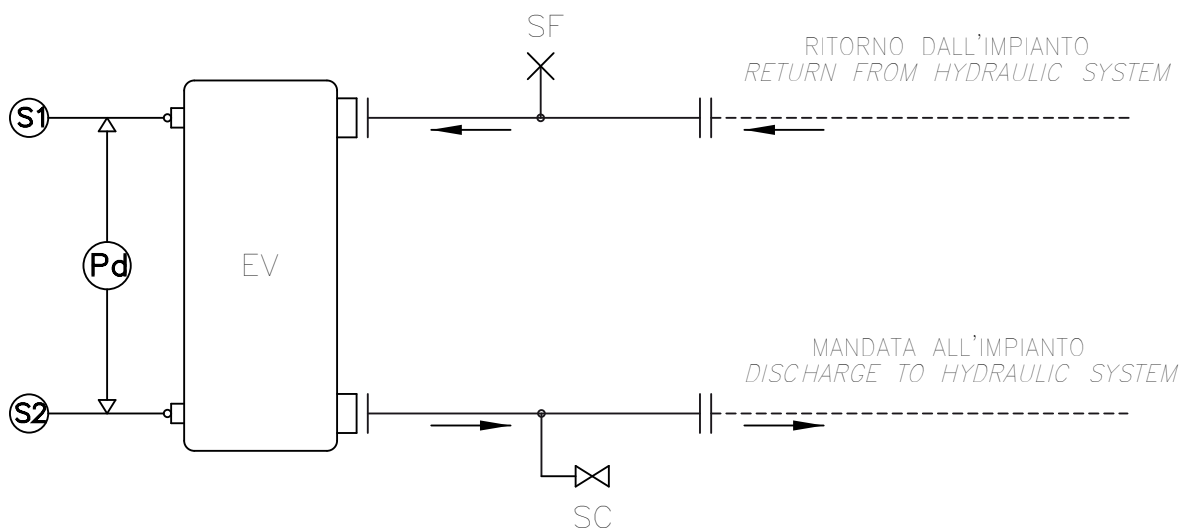
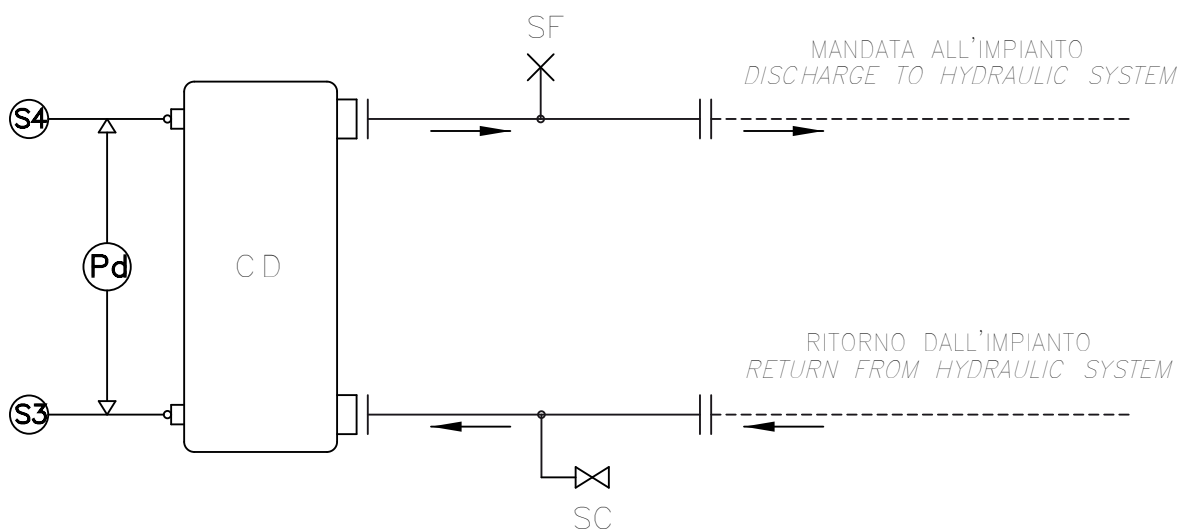

LEGENDA – LEGEND	
EV	Evaporatore Evaporator
CD	Condensatore Condenser
Pd	Pressostato differenziale Differential pressure switch
SC	Valvola di scarico Drain valve
SF	Valvola di sfiato Purge valve
S1	Sonda ingresso acqua evaporatore Evaporator water inlet probe
S2	Sonda uscita acqua evaporatore Evaporator water outlet probe
S3	Sonda ingresso acqua condensatore Condenser water inlet probe
S4	Sonda uscita acqua condensatore Condenser water outlet probe

11.1 ELECTRICAL DATA

NX-Q-G06

[SI System]

SIZE	Power supply V/ph/Hz	Maximum values								
		n	Compressor			Fans (1)		Total (1)(2)		
			F.L.I. [kW]	F.L.A. [A]	L.R.A. [A]	F.L.I. [kW]	F.L.A. [A]	F.L.I. [kW]	F.L.A. [A]	S.A. [A]
0604	400/3/50	4	4x15,36	4x24,9	4x172	2,100	4	69,80	115	262
0704	400/3/50	4	2x15,36+2x21,4	2x24,9+2x34,2	2x172+2x211	2,100	4	81,90	133	310
0804	400/3/50	4	4x21,4	4x34,2	4x211	2,100	4	94,00	152	329
0904	400/3/50	4	2x21,4+2x27	2x34,2+2x42,5	2x211+2x210	2,100	4	105,2	169	337
1004	400/3/50	4	4x27	4x42,5	4x210	2,100	4	120,6	193	360
1104	400/3/50	4	2x27+2x34,5	2x42,5+2x55,1	2x210+2x326	2,100	4	135,6	218	489
1204	400/3/50	4	4x34,5	4x55,1	4x326	2,100	4	150,6	243	514

F.L.I.: Full load power

F.L.A.: Full load current

L.R.A.: Locked rotor amperes for single compressor

S.A.: Inrush current

(1) Values calculated referring to the version with the maximum number of fans working at the max absorbed current

(1)(2) Safety values to be considered when cabling the unit for power supply and line-protections

Data valid for standard units without any additional option.

Plant (side) cooling exchanger water (in/out) 12,00°C/7,00°C; Source (side) heat exchanger air (in) 35,0°C.

Voltage tolerance: 10%

Maximum voltage unbalance: 3%

Give the typical operating conditions of units designed for outdoor installation, which can be associated (according to reference document IEC 60721) to the following classes:

- climatic conditions class 4K4H: air temperature range from -20 up to 55°C (*), relative humidity range from 4 up to 100%, with possible precipitations, at air pressure from 70 and 106 kPa and a maximum solar radiation of 1120 W/m2

- special climatic conditions negligible

- biological conditions class 4B1 and 4C2: locations in a generic urban area

- mechanically active substances class 4S2: locations in areas with sand or dust representative of urban areas

- mechanical conditions class 4M1: locations protected from significant vibrations or shocks

The required protection level for safe operation, according to reference document IEC 60529, is IP43XW (protection against access, to the most critical unit's parts, of external devices with diameter larger than 1 mm and rain).

The unit can be considered IP44XW protected, i.e. protected against access of external devices (with diameter larger than 1 mm) and water in general.

(*) for the unit's operating limits, see "selection limits" section

ELECTRICAL DATA

NX-Q-G06 /LN

[SI System]

SIZE	Power supply V/ph/Hz	Maximum values								
		n	Compressor			Fans (1)		Total (1)(2)		
			F.L.I. [kW]	F.L.A. [A]	L.R.A. [A]	F.L.I. [kW]	F.L.A. [A]	F.L.I. [kW]	F.L.A. [A]	S.A. [A]
0604	400/3/50	4	4x15,36	4x24,9	4x172	2,000	4	69,40	115	262
0704	400/3/50	4	2x15,36+2x21,4	2x24,9+2x34,2	2x172+2x211	2,000	4	81,50	133	310
0804	400/3/50	4	4x21,4	4x34,2	4x211	2,000	4	93,60	152	329
0904	400/3/50	4	2x21,4+2x27	2x34,2+2x42,5	2x211+2x210	2,000	4	104,8	169	337
1004	400/3/50	4	4x27	4x42,5	4x210	2,000	4	120,0	193	360
1104	400/3/50	4	2x27+2x34,5	2x42,5+2x55,1	2x210+2x326	2,000	4	135,0	218	489
1204	400/3/50	4	4x34,5	4x55,1	4x326	2,000	4	150,0	243	514

F.L.I.: Full load power

F.L.A.: Full load current

L.R.A.: Locked rotor amperes for single compressor

S.A.: Inrush current

(1) Values calculated referring to the version with the maximum number of fans working at the max absorbed current

(1)(2) Safety values to be considered when cabling the unit for power supply and line-protections

Data valid for standard units without any additional option.

Plant (side) cooling exchanger water (in/out) 12,00°C/7,00°C; Source (side) heat exchanger air (in) 35,0°C.

Voltage tolerance: 10%

Maximum voltage unbalance: 3%

Give the typical operating conditions of units designed for outdoor installation, which can be associated (according to reference document IEC 60721) to the following classes:

- climatic conditions class 4K4H: air temperature range from -20 up to 55°C (*), relative humidity range from 4 up to 100%, with possible precipitations, at air pressure from 70 and 106 kPa and a maximum solar radiation of 1120 W/m2

- special climatic conditions negligible

- biological conditions class 4B1 and 4C2: locations in a generic urban area

- mechanically active substances class 4S2: locations in areas with sand or dust representative of urban areas

- mechanical conditions class 4M1: locations protected from significant vibrations or shocks

The required protection level for safe operation, according to reference document IEC 60529, is IP43XW (protection against access, to the most critical unit's parts, of external devices with diameter larger than 1 mm and rain).

The unit can be considered IP44XW protected, i.e. protected against access of external devices (with diameter larger than 1 mm) and water in general.

(*) for the unit's operating limits, see "selection limits" section

ELECTRICAL DATA

NX-Q-G06 /SL

[SI System]

SIZE	Power supply V/ph/Hz	Maximum values								
		n	Compressor			Fans (1)		Total (1)(2)		
			F.L.I. [kW]	F.L.A. [A]	L.R.A. [A]	F.L.I. [kW]	F.L.A. [A]	F.L.I. [kW]	F.L.A. [A]	S.A. [A]
0604	400/3/50	4	4x15,36	4x24,9	4x172	1,200	4	66,20	115	262
0704	400/3/50	4	2x15,36+2x21,4	2x24,9+2x34,2	2x172+2x211	1,200	4	78,30	133	310
0804	400/3/50	4	4x21,4	4x34,2	4x211	1,200	4	92,80	160	336
0904	400/3/50	4	2x21,4+2x27	2x34,2+2x42,5	2x211+2x210	1,200	4	104,0	176	345
1004	400/3/50	4	4x27	4x42,5	4x210	1,200	4	115,2	193	360
1104	400/3/50	4	2x27+2x34,5	2x42,5+2x55,1	2x210+2x326	1,200	4	130,2	218	489
1204	400/3/50	4	4x34,5	4x55,1	4x326	1,200	4	147,6	251	522

F.L.I.: Full load power

F.L.A.: Full load current

L.R.A.: Locked rotor amperes for single compressor

S.A.: Inrush current

(1) Values calculated referring to the version with the maximum number of fans working at the max absorbed current

(1)(2) Safety values to be considered when cabling the unit for power supply and line-protections

Data valid for standard units without any additional option.

Plant (side) cooling exchanger water (in/out) 12,00°C/7,00°C; Source (side) heat exchanger air (in) 35,0°C.

Voltage tolerance: 10%

Maximum voltage unbalance: 3%

Give the typical operating conditions of units designed for outdoor installation, which can be associated (according to reference document IEC 60721) to the following classes:

- climatic conditions class 4K4H: air temperature range from -20 up to 55°C (*), relative humidity range from 4 up to 100%, with possible precipitations, at air pressure from 70 and 106 kPa and a maximum solar radiation of 1120 W/m2

- special climatic conditions negligible

- biological conditions class 4B1 and 4C2: locations in a generic urban area

- mechanically active substances class 4S2: locations in areas with sand or dust representative of urban areas

- mechanical conditions class 4M1: locations protected from significant vibrations or shocks

The required protection level for safe operation, according to reference document IEC 60529, is IP43XW (protection against access, to the most critical unit's parts, of external devices with diameter larger than 1 mm and rain).

The unit can be considered IP44XW protected, i.e. protected against access of external devices (with diameter larger than 1 mm) and water in general.

(*) for the unit's operating limits, see "selection limits" section

12.1 FULL LOAD SOUND LEVEL

NX-Q-G06

SOUND POWER LEVEL IN COOLING									
SIZE	Octave band [Hz]								Total sound level dB(A)
	63	125	250	500	1000	2000	4000	8000	
	Sound power level dB								
0604	92	90	89	88	88	85	78	71	92
0704	92	90	89	88	88	85	78	71	92
0804	92	90	89	88	88	85	78	71	92
0904	93	91	90	89	89	86	79	72	93
1004	94	92	91	90	90	87	80	73	94
1104	95	93	92	91	91	88	81	74	95
1204	95	93	92	91	91	88	81	74	95

Working conditions

Plant (side) cooling exchanger water (in/out) 12,00°C/7,00°C; Source (side) heat exchanger air (in) 35,0°C.

Sound power on the basis of measurements made in compliance with ISO 9614.

Such certification refers specifically to the sound Power Level in dB(A). This is therefore the only acoustic data to be considered as binding.

Sound power level in cooling, outdoors.

SOUND PRESSURE LEVEL									
SIZE	Octave band [Hz]								Total sound level dB(A)
	63	125	250	500	1000	2000	4000	8000	
	Sound pressure level dB								
0604	60	58	57	56	56	53	46	39	60
0704	60	58	57	56	56	53	46	39	60
0804	60	58	57	56	56	53	46	39	60
0904	61	59	58	57	57	54	47	40	61
1004	62	60	59	58	58	55	48	41	62
1104	63	61	60	59	59	56	49	42	63
1204	63	61	60	59	59	56	49	42	63

Working conditions

Plant (side) cooling exchanger water (in/out) 12,00°C/7,00°C; Source (side) heat exchanger air (in) 35,0°C.

Average sound pressure level at 10m distance, unit in a free field on a reflective surface; non-binding value calculated from the sound power level.

FULL LOAD SOUND LEVEL

NX-Q-G06

SOUND POWER LEVEL IN HEATING									
SIZE	Octave band [Hz]								Total sound level dB(A)
	63	125	250	500	1000	2000	4000	8000	
	Sound power level dB								
0604	0	0	0			0	0	0	92
0704	0	0	0			0	0	0	92
0804	0	0	0			0	0	0	92
0904	0	0	0			0	0	0	93
1004	0	0	0			0	0	0	94
1104	0	0	0			0	0	0	95
1204	0	0	0			0	0	0	95

NOT AVAILABLE

Working conditions

Sound power on the basis of measurements made in compliance with ISO 9614.

Such certification refers specifically to the sound Power Level in dB(A). This is therefore the only acoustic data to be considered as binding.

Sound power level in heating, outdoors.

SOUND PRESSURE LEVEL									
SIZE	Octave band [Hz]								Total sound level dB(A)
	63	125	250	500	1000	2000	4000	8000	
	Sound pressure level dB								
0604	0	0	0			0	0	0	60
0704	0	0	0			0	0	0	60
0804	0	0	0			0	0	0	60
0904	0	0	0			0	0	0	61
1004	0	0	0			0	0	0	62
1104	0	0	0			0	0	0	63
1204	0	0	0			0	0	0	63

NOT AVAILABLE

Working conditions

FULL LOAD SOUND LEVEL

NX-Q-G06 /LN

SOUND POWER LEVEL IN COOLING									
SIZE	Octave band [Hz]								Total sound level dB(A)
	63	125	250	500	1000	2000	4000	8000	
	Sound power level dB								
0604	90	85	85	84	82	76	69	62	86
0704	90	85	85	84	82	76	69	62	86
0804	90	85	85	84	82	76	69	62	86
0904	91	86	86	85	83	77	70	63	87
1004	92	87	87	86	84	78	71	64	88
1104	93	88	88	87	85	79	72	65	89
1204	93	88	88	87	85	79	72	65	89

Working conditions

Plant (side) cooling exchanger water (in/out) 12,00°C/7,00°C; Source (side) heat exchanger air (in) 35,0°C.

Sound power on the basis of measurements made in compliance with ISO 9614.

Such certification refers specifically to the sound Power Level in dB(A). This is therefore the only acoustic data to be considered as binding.

Sound power level in cooling, outdoors.

SOUND PRESSURE LEVEL									
SIZE	Octave band [Hz]								Total sound level dB(A)
	63	125	250	500	1000	2000	4000	8000	
	Sound pressure level dB								
0604	58	53	53	52	50	44	37	30	54
0704	58	53	53	52	50	44	37	30	54
0804	58	53	53	52	50	44	37	30	54
0904	59	54	54	53	51	45	38	31	55
1004	60	55	55	54	52	46	39	32	56
1104	61	56	56	55	53	47	40	33	57
1204	61	56	56	55	53	47	40	33	57

Working conditions

Plant (side) cooling exchanger water (in/out) 12,00°C/7,00°C; Source (side) heat exchanger air (in) 35,0°C.

Average sound pressure level at 10m distance, unit in a free field on a reflective surface; non-binding value calculated from the sound power level.

FULL LOAD SOUND LEVEL

NX-Q-G06 /LN

SOUND POWER LEVEL IN HEATING										
SIZE	Octave band [Hz]								Total sound level dB(A)	
	63	125	250	500	1000	2000	4000	8000		
	Sound power level dB									
0604	0	0	0	NOT AVAILABLE			0	0	0	87
0704	0	0	0				0	0	0	87
0804	0	0	0				0	0	0	87
0904	0	0	0				0	0	0	88
1004	0	0	0				0	0	0	89
1104	0	0	0				0	0	0	90
1204	0	0	0				0	0	0	90

Working conditions

Sound power on the basis of measurements made in compliance with ISO 9614.

Such certification refers specifically to the sound Power Level in dB(A). This is therefore the only acoustic data to be considered as binding.

Sound power level in heating, outdoors.

SOUND PRESSURE LEVEL										
SIZE	Octave band [Hz]								Total sound level dB(A)	
	63	125	250	500	1000	2000	4000	8000		
	Sound pressure level dB									
0604	0	0	0	NOT AVAILABLE			0	0	0	55
0704	0	0	0				0	0	0	55
0804	0	0	0				0	0	0	55
0904	0	0	0				0	0	0	56
1004	0	0	0				0	0	0	57
1104	0	0	0				0	0	0	58
1204	0	0	0				0	0	0	58

Working conditions

FULL LOAD SOUND LEVEL

NX-Q-G06 /SL

SOUND POWER LEVEL IN COOLING									
SIZE	Octave band [Hz]								Total sound level dB(A)
	63	125	250	500	1000	2000	4000	8000	
	Sound power level dB								
0604	92	84	83	81	77	71	65	61	82
0704	92	84	83	81	77	71	65	61	82
0804	92	84	84	82	78	72	66	61	83
0904	92	84	84	82	78	72	66	61	83
1004	92	84	84	82	78	72	66	61	83
1104	94	86	86	84	80	74	68	63	85
1204	95	87	87	85	81	75	69	64	86

Working conditions

Plant (side) cooling exchanger water (in/out) 12,00°C/7,00°C; Source (side) heat exchanger air (in) 35,0°C.

Sound power on the basis of measurements made in compliance with ISO 9614.

Such certification refers specifically to the sound Power Level in dB(A). This is therefore the only acoustic data to be considered as binding.

Sound power level in cooling, outdoors.

SOUND PRESSURE LEVEL									
SIZE	Octave band [Hz]								Total sound level dB(A)
	63	125	250	500	1000	2000	4000	8000	
	Sound pressure level dB								
0604	60	52	51	49	45	39	33	29	50
0704	60	52	51	49	45	39	33	29	50
0804	60	52	52	50	46	40	34	29	51
0904	60	52	52	50	46	40	34	29	51
1004	60	52	52	50	46	40	34	29	51
1104	62	54	54	52	48	42	36	31	53
1204	63	55	55	53	49	43	37	32	54

Working conditions

Plant (side) cooling exchanger water (in/out) 12,00°C/7,00°C; Source (side) heat exchanger air (in) 35,0°C.

Average sound pressure level at 10m distance, unit in a free field on a reflective surface; non-binding value calculated from the sound power level.

FULL LOAD SOUND LEVEL

NX-Q-G06 /SL

SOUND POWER LEVEL IN HEATING										
SIZE	Octave band [Hz]								Total sound level dB(A)	
	63	125	250	500	1000	2000	4000	8000		
	Sound power level dB									
0604	0	0	0	NOT AVAILABLE			0	0	0	83
0704	0	0	0				0	0	0	83
0804	0	0	0				0	0	0	84
0904	0	0	0				0	0	0	84
1004	0	0	0				0	0	0	84
1104	0	0	0				0	0	0	86
1204	0	0	0				0	0	0	87

Working conditions

Sound power on the basis of measurements made in compliance with ISO 9614.

Such certification refers specifically to the sound Power Level in dB(A). This is therefore the only acoustic data to be considered as binding.

Sound power level in heating, outdoors.

SOUND PRESSURE LEVEL										
SIZE	Octave band [Hz]								Total sound level dB(A)	
	63	125	250	500	1000	2000	4000	8000		
	Sound pressure level dB									
0604	0	0	0	NOT AVAILABLE			0	0	0	51
0704	0	0	0				0	0	0	51
0804	0	0	0				0	0	0	52
0904	0	0	0				0	0	0	52
1004	0	0	0				0	0	0	52
1104	0	0	0				0	0	0	54
1204	0	0	0				0	0	0	55

Working conditions

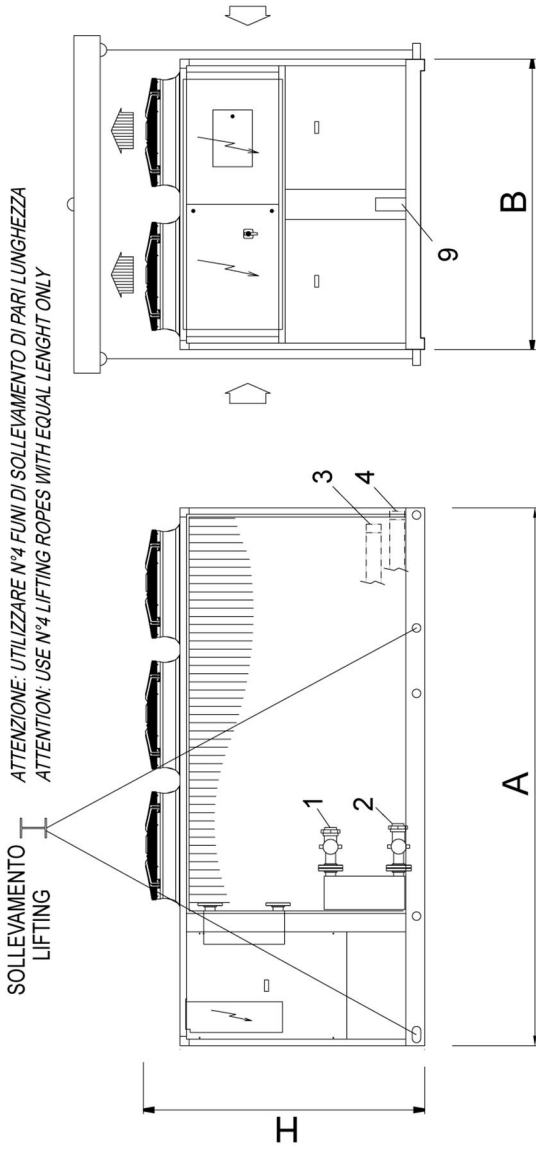

STANDARD UNIT OR UNIT WITH HYDRONIC KIT 2 + 2 PUMPS

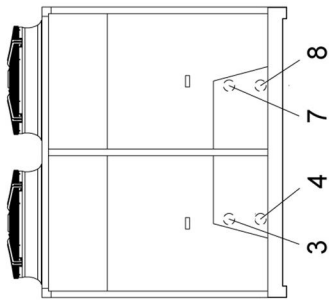

UNIT WITH HYDRONIC KIT 1 + 1 PUMPS

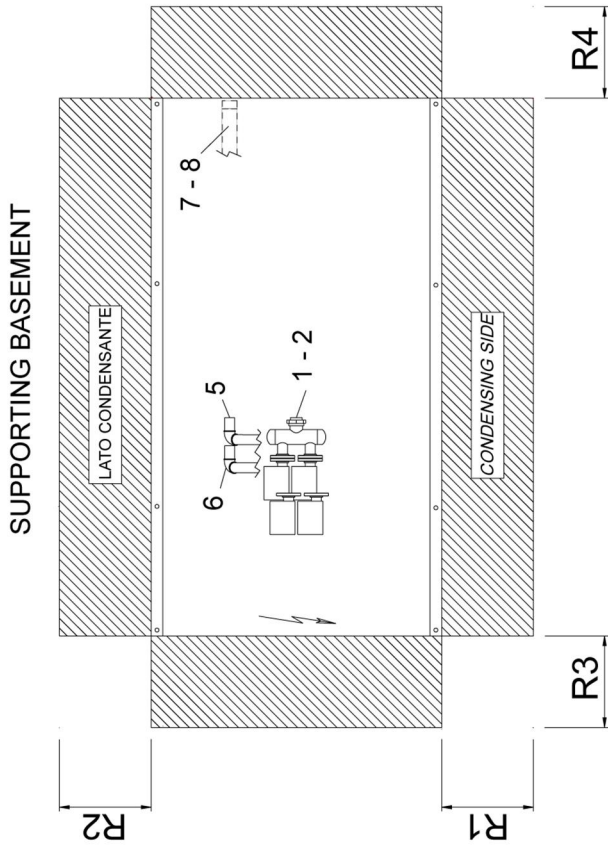
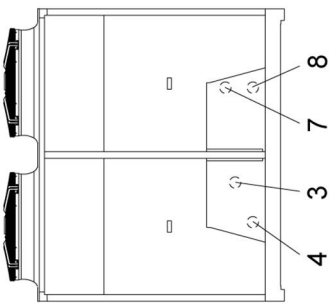

- 1 ENTRATA ACQUA EVAPORATORE
EVAPORATOR WATER INLET
- 2 USCITA ACQUA EVAPORATORE
EVAPORATOR WATER OUTLET
- 3 ENTRATA ACQUA EVAPORATORE OPZIONALE
OPTIONAL EVAPORATOR WATER INLET
- 4 USCITA ACQUA EVAPORATORE OPZIONALE
OPTIONAL EVAPORATOR WATER OUTLET
- 5 ENTRATA ACQUA RECUPERATORE
RECUPERATOR WATER INLET
- 6 USCITA ACQUA RECUPERATORE
RECUPERATOR WATER OUTLET
- 7 ENTRATA ACQUA RECUPERATORE OPZIONALE
OPTIONAL RECUPERATOR WATER INLET
- 8 USCITA ACQUA RECUPERATORE OPZIONALE
OPTIONAL RECUPERATOR WATER OUTLET
- 9 INGRESSO LINEA ELETTRICA (FORO PRETRANCIATO)
POWER INLET (HOLE PRE-CUT)

REMARKS: For installation purposes, please refer to the documentation sent after the purchase contract. This technical data should be considered as indicative. Mitsubishi Electric Hydraulics & IT Cooling Systems S.p.A. may modify them at any moment. Data valid for standard units without any additional option.

DIMENSIONAL DRAWINGS

NX-Q-G06 0604 - 1204

[SI System]

SIZE	DIMENSIONS AND WEIGHTS				CLEARANCE				CHILLED WATER HEAT EX. USER SIDE		WARM WATER HEAT EX. USER SIDE	
	A	B	H	WEIGHT	R1	R2	R3	R4	IN/OUT		IN/OUT	
	[mm]	[mm]	[mm]	[kg]	[mm]	[mm]	[mm]	[mm]	TYPE	Ø	TYPE	Ø
NX-Q-G06 0604	3110	2220	2150	1660	2000	2000	1100	1100	B1	2"1/2	B1	2"1/2
NX-Q-G06 0704	3110	2220	2150	1730	2000	2000	1100	1100	B1	2"1/2	B1	2"1/2
NX-Q-G06 0804	3110	2220	2150	1850	2000	2000	1100	1100	B1	3"	B1	3"
NX-Q-G06 0904	4110	2220	2150	2130	2000	2000	1100	1100	B1	3"	B1	3"
NX-Q-G06 1004	4110	2220	2150	2370	2000	2000	1100	1100	B1	3"	B1	3"
NX-Q-G06 1104	4110	2220	2150	2540	2000	2000	1100	1100	B1	4"	B1	4"
NX-Q-G06 1204	4110	2220	2150	2680	2000	2000	1100	1100	B1	4"	B1	4"
NX-Q-G06 /LN 0604	3110	2220	2150	1660	2000	2000	1100	1100	B1	2"1/2	B1	2"1/2
NX-Q-G06 /LN 0704	3110	2220	2150	1730	2000	2000	1100	1100	B1	2"1/2	B1	2"1/2
NX-Q-G06 /LN 0804	3110	2220	2150	1850	2000	2000	1100	1100	B1	3"	B1	3"
NX-Q-G06 /LN 0904	4110	2220	2150	2130	2000	2000	1100	1100	B1	3"	B1	3"
NX-Q-G06 /LN 1004	4110	2220	2150	2370	2000	2000	1100	1100	B1	3"	B1	3"
NX-Q-G06 /LN 1104	4110	2220	2150	2540	2000	2000	1100	1100	B1	4"	B1	4"
NX-Q-G06 /LN 1204	4110	2220	2150	2680	2000	2000	1100	1100	B1	4"	B1	4"
NX-Q-G06 /SL 0604	3110	2220	2150	1750	2000	2000	1100	1100	B1	2"1/2	B1	2"1/2
NX-Q-G06 /SL 0704	3110	2220	2150	1850	2000	2000	1100	1100	B1	2"1/2	B1	2"1/2
NX-Q-G06 /SL 0804	4110	2220	2150	2070	2000	2000	1100	1100	B1	3"	B1	3"
NX-Q-G06 /SL 0904	4110	2220	2150	2230	2000	2000	1100	1100	B1	3"	B1	3"
NX-Q-G06 /SL 1004	4110	2220	2150	2480	2000	2000	1100	1100	B1	3"	B1	3"
NX-Q-G06 /SL 1104	5110	2220	2150	2810	2000	2000	1100	1100	B1	4"	B1	4"
NX-Q-G06 /SL 1204	5110	2220	2150	2930	2000	2000	1100	1100	B1	4"	B1	4"

DIMENSIONAL DRAWINGS

LEGEND OF PIPE CONNECTIONS

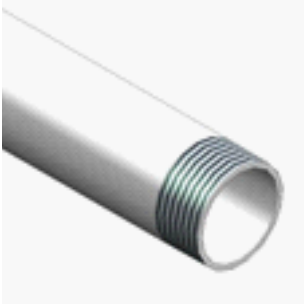

TYPE = B
Male threaded pipe

NOMINAL PIPE SIZE	PIPE OUTSIDE DIAMETER
ø inches	ø mm
¾	26,7
1	33,7
1 ¼	42,4
1 ½	48,3
2	60,3
2 ½	76,1
3	88,9
3 ½	101,6

NOMINAL PIPE SIZE	PIPE OUTSIDE DIAMETER
ø inches	ø mm
4	114,3
4 ½	127,0
5	139,7
6	168,3
8	219,1
10	273,0
12	323,9
14	355,6

UNI ISO 228/13

Pipe threads where pressure-tight joints are not made on the threads - Designation, dimensions and tolerances

Used terminology:

G: Pipe threads where pressure-tight joints are not made on the threads

A: Close tolerance class for external pipe threads where pressure-tight joints are not made on the threads

B: Wider tolerance class for external pipe threads where pressure-tight joints are not made on the threads

Internal threads: G letter followed by thread mark (only tolerance class)

External threads: G letter followed by thread mark and by A letter for A class external threads or by B letter for B class external threads.

UNI EN 10226-1

Pipe threads where pressure-tight joints are made on the threads - Designation, dimensions and tolerances

Used terminology:

Rp: Internal cylindrical threads where pressure-tight joints are made on the threads

Rc: Internal conical threads where pressure-tight joints are made on the threads

R: External conical threads where pressure-tight joints are made on the threads

Internal cylindrical threads: R letter followed by p letter

Internal conical threads: R letter followed by c letter

External conical threads: R letter

DESIGNATION	DESCRIPTION
UNI EN 10226-1 - Rp 1 1/2	Internal cylindrical threads where pressure-tight joints are made on the threads, defined by standard UNI ISO 7/1 Conventional ø 1 1/2"
UNI EN 10226-1 - Rp 2 1/2	Internal cylindrical threads where pressure-tight joints are made on the threads, defined by standard UNI ISO 7/1 Conventional ø 2 1/2"
UNI EN 10226-1 - Rp 3	Internal cylindrical threads where pressure-tight joints are made on the threads, defined by standard UNI ISO 7/1 Conventional ø 3"
UNI EN 10226-1 - R 3	External conical threads where pressure-tight joints are made on the threads, defined by standard UNI ISO 7/1 Conventional ø 3"
UNI ISO 228/1 - G 4 B	Internal cylindrical threads where pressure-tight joints are not made on the threads, defined by standard UNI ISO 228/1 Tolerance class B for external thread Conventional ø 4"
DN 80 PN 16	Flange Nominal Diameter: 80 mm Nominal Pressure: 16 bar

NOTE:

Conventional diameter value [in inches] identifies short thread designation, based upon the relative standard.

All relative values are defined by standards.

As example, here below some values:

	UNI EN 10226-1	UNI ISO 228/1
Conventional ø	1"	1"
Pitch	2.309 mm	2.309 mm
External ø	33.249 mm	33.249 mm
Core ø	30.291 mm	30.291 mm
Thread height	1.479 mm	1.479 mm

14.1 HYDRONIC GROUP

14.1 HYDRONIC GROUP

The units can be fitted with the following types hydronic module:

- Only terminals (ON/OFF or modulating)

The hydronic module allows to control the external pumps with the unit controller logic.

- Pumps (fixed or variable speed)

The hydronic module includes the pumps and the main water circuit components, thus optimizing hydraulic and electrical installation space, time and costs.

The complete list of the options available is present in the accessory section of the bulletin.

For the hydronic modules with only terminals, the factory-mounted components are:

- Terminals for external pumps control (only relays or relays + 0-10V signal)
- Differential pressure switch (on heat exchanger)
- Drain valve (on heat exchanger)

For the hydronic modules with pumps, the factory-mounted components are:

- 1 or 2 pumps, 2 poles, low or high head, fixed speed or variable speed (inverter)
- Pump suction and discharge valves
- One-way valve (Clapet type for in-line pumps)
- Purge valve
- Drain plug
- Differential pressure switch (on heat exchanger)
- Drain valve (on heat exchanger)
- 10 mm insulation lining on pumps and pipes

The pumps are controlled in duty/standby, with running hours equalization and changeover on device failure.

The electrical panel of the unit is protected with fuses and contactors with thermals cut-out.

Each of the components of the hydraulic group has been designed to optimise hydraulic and electrical installation space, time and costs.

The hydronic group is protected by a special casing ventilating (versions LN and SL).

The hydronic kit of this family includes in-line pumps.

14.1 IN-LINE PUMPS

Low or high head pumps

Centrifugal pumps with in-line suction and delivery flanges, in single or twin versions. Pump body in cast iron and impeller in AISI 316L stainless steel or cast-iron, entirely laser technology welded. Mechanical seal with EPDM elastomers. Three-phase electric motor protected to IP55, insulation class F, suitable for continuous service.

14.1 SPECIAL PUMPS

For pumps with different configurations, please contact our sales department.

14.1 OTHER COMPONENTS

The hydronic kits do not include the following accessories though these are recommended to ensure correct system operation:

- Flow-out switch
- Pressure gauges upline and downline from the unit
- Flexible joints on piping
- On-off valves
- Outlet control thermometer
- Mains filter.

Possible configurations

PUMP GROUP	Versions		
		LN	SL
EV - 1 PUMP 4P LH (FIX SPEED)(4704)	X	X	X
EV - 1 PUMP 2P LH (FIX SPEED)(4706)	X	X	X
EV - 1 PUMP 2P HP (FIX SPEED)(4707)	X	X	X

PUMP GROUP	Versions		
		LN	SL
EV - 2 PUMPS 4P LH (FIX SPEED)(4708)	X	X	X
EV - 2 PUMPS 2P LH (FIX SPEED)(4711)	X	X	X
EV - 2 PUMPS 2P HP (FIX SPEED)(4712)	X	X	X
EV - 1 PUMP 2P LH (VAR SPEED)(4717)	X	X	X
EV - 1 PUMP 2P HH (VAR SPEED)(4718)	X	X	X
EV - 2 PUMPS 2P LH (FIX SPEED)(4722)	X (1)	X (1)	X (2)
EV - 2 PUMPS 2P HH (VAR SPEED)(4723)	X (1)	X (1)	X (2)
CD - 1 PUMP 4P LH (FIX SPEED)(4764)	X	X	X
CD - 1 PUMP 2P LH (FIX SPEED)(4766)	X	X	X
CD - 1 PUMP 2P HH (FIX SPEED)(4767)	X	X	X
CD - 2 PUMPS 4P LH (FIX SPEED)(4768)	X	X	X
CD - 2 PUMPS 2P LH (FIX SPEED)(4771)	X	X	X
CD - 2 PUMPS 2P HH (FIX SPEED)(4772)	X	X	X
CD - 1 PUMP 2P BP (VAR SPEED)(4777)	X	X	X
CD - 1 POMPA 2P AP (VAR SPEED)(4778)	X	X	X
CD - 2 PUMPS 2P BP (VAR SPEED)(4782)	X (1)	X (1)	X (2)
CD - 2 POMPE 2P AP (VAR SPEED)(4783)	X (1)	X (1)	X (2)

(1) Not available for sizes 0604, 0704 and 0804

(2) Not available for sizes 0604 and 0704

HYDRONIC GROUP

SCHEMA IDRAULICO CON 1-2 POMPE HYDRAULIC DIAGRAM WITH 1-2 PUMPS

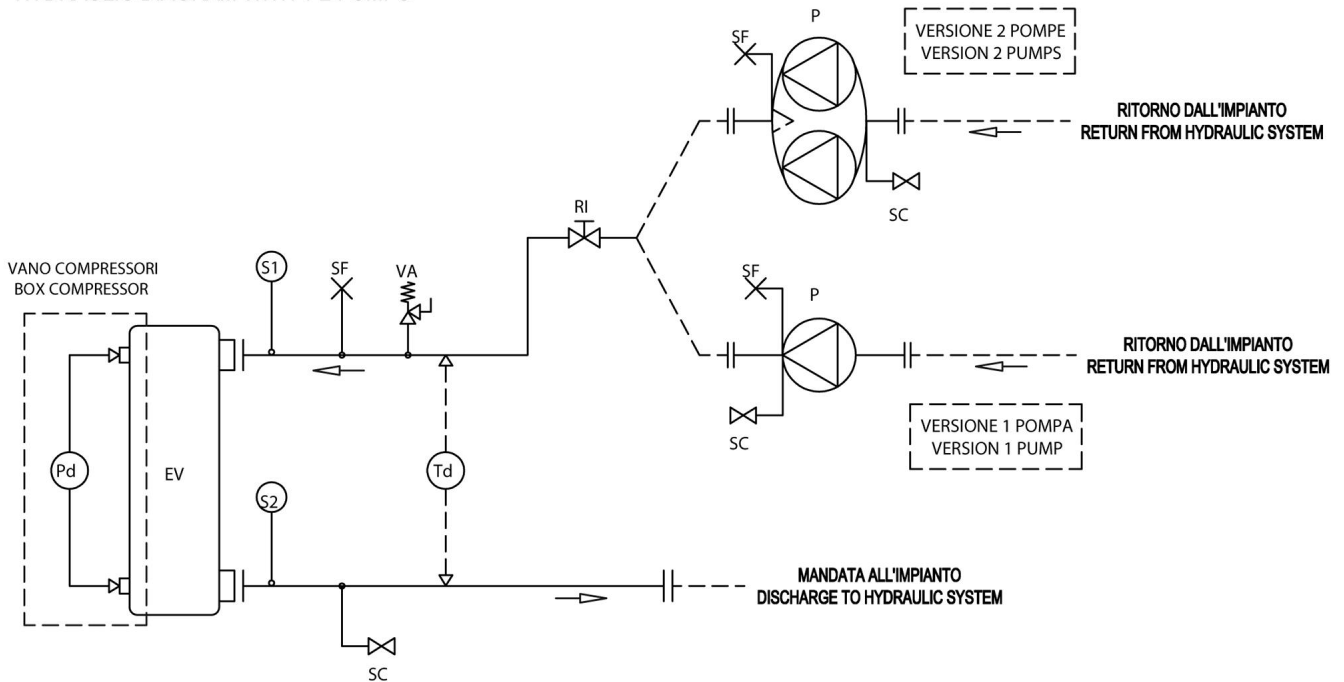

SOLO PER /D
ONLY FOR /D

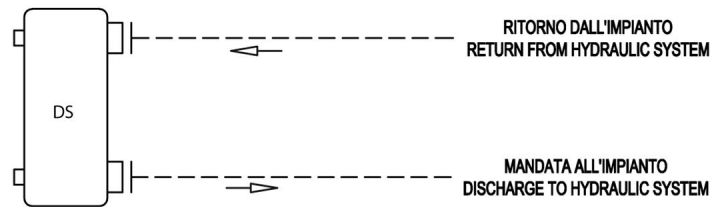

LEGENDA - LEGEND	
DS	Desurriscaldatore (scambiatore a piastre - opzionale) Desuperheater (plate exchanger - optional)
EV	Evaporatore (scambiatore a piastre) Evaporator (plate exchanger)
P	Pompa di circolazione Available pressure pump
Pd	Pressostato differenziale Differential pressure switch
RI	Rubinetto di intercettazione Shut-off valve
SC	Valvola di scarico Drain valve
SF	Valvola di sfiato aria Purge valve
S1/2	Sonda temperatura acqua Water temperature probe
Td	Trasduttore di pressione differenziale (solo con VPF) Differential pressure transducer (only with VPF)
VA	Valvola di sicurezza Safety valve

HYDRONIC GROUP

Hydronic kit positioning

	Version	EV - 1 PUMP 4P LH (FIX SPEED) (4704)				EV - 1 PUMP 2P LH (FIX SPEED) (4706)				EV - 1 PUMP 2P HP (FIX SPEED) (4707)				EV - 2 PUMPS 4P LH (FIX SPEED) (4708)			
		extra L [mm]	extra W [mm]	extra H [mm]	extra WGT [kg]	extra L [mm]	extra W [mm]	extra H [mm]	extra WGT [kg]	extra L [mm]	extra W [mm]	extra H [mm]	extra WGT [kg]	extra L [mm]	extra W [mm]	extra H [mm]	extra WGT [kg]
0604		/	/	/	-	/	/	/	-	/	/	/	-	/	/	/	-
	LN	/	/	/	-	/	/	/	-	/	/	/	-	/	/	/	-
	SL	/	/	/	-	/	/	/	-	/	/	/	-	/	/	/	-
0704		/	/	/	-	/	/	/	-	/	/	/	-	/	/	/	-
	LN	/	/	/	-	/	/	/	-	/	/	/	-	/	/	/	-
	SL	/	/	/	-	/	/	/	-	/	/	/	-	/	/	/	-
0804		/	/	/	-	/	/	/	-	/	/	/	-	/	/	/	-
	LN	/	/	/	-	/	/	/	-	/	/	/	-	/	/	/	-
	SL	/	/	/	-	/	/	/	-	/	/	/	-	/	/	/	-
0904		/	/	/	-	/	/	/	-	/	/	/	-	/	/	/	-
	LN	/	/	/	-	/	/	/	-	/	/	/	-	/	/	/	-
	SL	/	/	/	-	/	/	/	-	/	/	/	-	/	/	/	-
1004		/	/	/	-	/	/	/	-	/	/	/	-	/	/	/	-
	LN	/	/	/	-	/	/	/	-	/	/	/	-	/	/	/	-
	SL	/	/	/	-	/	/	/	-	/	/	/	-	/	/	/	-
1104		/	/	/	-	/	/	/	-	/	/	/	-	/	/	/	-
	LN	/	/	/	-	/	/	/	-	/	/	/	-	/	/	/	-
	SL	/	/	/	-	/	/	/	-	/	/	/	-	/	/	/	-
1204		/	/	/	-	/	/	/	-	/	/	/	-	/	/	/	-
	LN	/	/	/	-	/	/	/	-	/	/	/	-	/	/	/	-
	SL	/	/	/	-	/	/	/	-	/	/	/	-	/	/	/	-

NOT AVAILABLE

extra L	Unit's extra length
extra W	Unit's extra operating width (NOT to be considered for transport)
extra H	Unit's extra height
extra H	Unit's extra weight (pumps and piping)
EV - 1 PUMP 4P LH (FIX SPEED)	EV - 1 PUMP 4P LH (FIX SPEED)
EV - 1 PUMP 2P LH (FIX SPEED)	EV - 1 PUMP 2P LH (FIX SPEED)
EV - 1 PUMP 2P HP (FIX SPEED)	EV - 1 PUMP 2P HP (FIX SPEED)
EV - 2 PUMPS 4P LH (FIX SPEED)	EV - 2 PUMPS 4P LH (FIX SPEED)
-	Not available

HYDRONIC GROUP

Hydronic kit positioning

	Version	EV - 2 PUMPS 2P LH (FIX SPEED) (4711)				EV - 2 PUMPS 2P HP (FIX SPEED) (4712)				EV - 1 PUMP 2P LH (VAR SPEED) (4717)				EV - 1 PUMP 2P HH (VAR SPEED) (4718)			
		extra L [mm]	extra W [mm]	extra H [mm]	extra WGT [kg]	extra L [mm]	extra W [mm]	extra H [mm]	extra WGT [kg]	extra L [mm]	extra W [mm]	extra H [mm]	extra WGT [kg]	extra L [mm]	extra W [mm]	extra H [mm]	extra WGT [kg]
0604		/	/	/	-	/	/	/	-	/	/	/	-	/	/	/	-
	LN	/	/	/	-	/	/	/	-	/	/	/	-	/	/	/	-
	SL	/	/	/	-	/	/	/	-	/	/	/	-	/	/	/	-
0704		/	/	/	-	/	/	/	-	/	/	/	-	/	/	/	-
	LN	/	/	/	-	/	/	/	-	/	/	/	-	/	/	/	-
	SL	/	/	/	-	/	/	/	-	/	/	/	-	/	/	/	-
0804		/	/	/	-	/	/	/	-	/	/	/	-	/	/	/	-
	LN	/	/	/	-	/	/	/	-	/	/	/	-	/	/	/	-
	SL	/	/	/	-	/	/	/	-	/	/	/	-	/	/	/	-
0904		/	/	/	-	/	/	/	-	/	/	/	-	/	/	/	-
	LN	/	/	/	-	/	/	/	-	/	/	/	-	/	/	/	-
	SL	/	/	/	-	/	/	/	-	/	/	/	-	/	/	/	-
1004		/	/	/	-	/	/	/	-	/	/	/	-	/	/	/	-
	LN	/	/	/	-	/	/	/	-	/	/	/	-	/	/	/	-
	SL	/	/	/	-	/	/	/	-	/	/	/	-	/	/	/	-
1104		/	/	/	-	/	/	/	-	/	/	/	-	/	/	/	-
	LN	/	/	/	-	/	/	/	-	/	/	/	-	/	/	/	-
	SL	/	/	/	-	/	/	/	-	/	/	/	-	/	/	/	-
1204		/	/	/	-	/	/	/	-	/	/	/	-	/	/	/	-
	LN	/	/	/	-	/	/	/	-	/	/	/	-	/	/	/	-
	SL	/	/	/	-	/	/	/	-	/	/	/	-	/	/	/	-

NOT AVAILABLE

extra L	Unit's extra length
extra W	Unit's extra operating width (NOT to be considered for transport)
extra H	Unit's extra height
extra H	Unit's extra weight (pumps and piping)
EV - 2 PUMPS 2P LH (FIX SPEED)	EV - 2 PUMPS 2P LH (FIX SPEED)
EV - 2 PUMPS 2P HP (FIX SPEED)	EV - 2 PUMPS 2P HP (FIX SPEED)
EV - 1 PUMP 2P LH (VAR SPEED)	EV - 1 PUMP 2P LH (VAR SPEED)
EV - 1 PUMP 2P HH (VAR SPEED)	EV - 1 PUMP 2P HH (VAR SPEED)
-	Not available

HYDRONIC GROUP

Hydronic kit positioning

	Version	EV - 2 PUMPS 2P LH (VAR SPEED) (4722)				EV - 2 PUMPS 2P HH (VAR SPEED) (4723)				CD - 1 PUMP 4P LH (FIX SPEED) (4764)				CD - 1 PUMP 2P LH (FIX SPEED) (4766)			
		extra L [mm]	extra W [mm]	extra H [mm]	extra WGT [kg]	extra L [mm]	extra W [mm]	extra H [mm]	extra WGT [kg]	extra L [mm]	extra W [mm]	extra H [mm]	extra WGT [kg]	extra L [mm]	extra W [mm]	extra H [mm]	extra WGT [kg]
0604		/	/	/	-	/	/	/	-	/	/	/	-	/	/	/	-
	LN	/	/	/	-	/	/	/	-	/	/	/	-	/	/	/	-
	SL	/	/	/	-									/	/	/	-
0704		/	/	/	-									/	/	/	-
	LN	/	/	/	-									/	/	/	-
	SL	/	/	/	-									/	/	/	-
0804		/	/	/	-									/	/	/	-
	LN	/	/	/	-									/	/	/	-
	SL	/	/	/	-									/	/	/	-
0904		/	/	/	-									/	/	/	-
	LN	/	/	/	-									/	/	/	-
	SL	/	/	/	-									/	/	/	-
1004		/	/	/	-									/	/	/	-
	LN	/	/	/	-									/	/	/	-
	SL	/	/	/	-									/	/	/	-
1104		/	/	/	-									/	/	/	-
	LN	/	/	/	-	/	/	/	-	/	/	/	-	/	/	/	-
	SL	/	/	/	-	/	/	/	-	/	/	/	-	/	/	/	-
1204		/	/	/	-	/	/	/	-	/	/	/	-	/	/	/	-
	LN	/	/	/	-	/	/	/	-	/	/	/	-	/	/	/	-
	SL	/	/	/	-	/	/	/	-	/	/	/	-	/	/	/	-

NOT AVAILABLE

- extra L** Unit's extra length
- extra W** Unit's extra operating width (NOT to be considered for transport)
- extra H** Unit's extra height
- extra H** Unit's extra weight (pumps and piping)
- EV - 2 PUMPS 2P LH (VAR SPEED)** EV - 2 PUMPS 2P LH (VAR SPEED)
- EV - 2 PUMPS 2P HH (VAR SPEED)** EV - 2 PUMPS 2P HH (VAR SPEED)
- CD - 1 PUMP 4P LH (FIX SPEED)** CD - 1 PUMP 4P LH (FIX SPEED)
- CD - 1 PUMP 2P LH (FIX SPEED)** CD - 1 PUMP 2P LH (FIX SPEED)
- Not available

HYDRONIC GROUP

Hydronic kit positioning

	Version	CD - 1 PUMP 2P HH (FIX SPEED) (4767)				CD - 2 PUMPS 4P LH (FIX SPEED) (4768)				CD - 2 PUMPS 2P LH (FIX SPEED) (4771)				CD - 2 PUMPS 2P HH (FIX SPEED) (4772)			
		extra L [mm]	extra W [mm]	extra H [mm]	extra WGT [kg]	extra L [mm]	extra W [mm]	extra H [mm]	extra WGT [kg]	extra L [mm]	extra W [mm]	extra H [mm]	extra WGT [kg]	extra L [mm]	extra W [mm]	extra H [mm]	extra WGT [kg]
0604		/	/	/	-	/	/	/	-	/	/	/	-	/	/	/	-
	LN	/	/	/	-	/	/	/	-	/	/	/	-	/	/	/	-
	SL	/	/	/	-					/	/	/	-	/	/	/	-
0704		/	/	/	-					/	/	/	-	/	/	/	-
	LN	/	/	/	-					/	/	/	-	/	/	/	-
	SL	/	/	/	-					/	/	/	-	/	/	/	-
0804		/	/	/	-					/	/	/	-	/	/	/	-
	LN	/	/	/	-					/	/	/	-	/	/	/	-
	SL	/	/	/	-					/	/	/	-	/	/	/	-
0904		/	/	/	-					/	/	/	-	/	/	/	-
	LN	/	/	/	-					/	/	/	-	/	/	/	-
	SL	/	/	/	-					/	/	/	-	/	/	/	-
1004		/	/	/	-					/	/	/	-	/	/	/	-
	LN	/	/	/	-					/	/	/	-	/	/	/	-
	SL	/	/	/	-					/	/	/	-	/	/	/	-
1104		/	/	/	-					/	/	/	-	/	/	/	-
	LN	/	/	/	-	/	/	/	-	/	/	/	-	/	/	/	-
	SL	/	/	/	-	/	/	/	-	/	/	/	-	/	/	/	-
1204		/	/	/	-	/	/	/	-	/	/	/	-	/	/	/	-
	LN	/	/	/	-	/	/	/	-	/	/	/	-	/	/	/	-
	SL	/	/	/	-	/	/	/	-	/	/	/	-	/	/	/	-

NOT AVAILABLE

- extra L Unit's extra length
- extra W Unit's extra operating width (NOT to be considered for transport)
- extra H Unit's extra height
- extra H Unit's extra weight (pumps and piping)
- CD - 1 PUMP 2P HH (FIX SPEED) CD - 1 PUMP 2P HH (FIX SPEED)
- CD - 2 PUMPS 4P LH (FIX SPEED) CD - 2 PUMPS 4P LH (FIX SPEED)
- CD - 2 PUMPS 2P LH (FIX SPEED) CD - 2 PUMPS 2P LH (FIX SPEED)
- CD - 2 PUMPS 2P HH (FIX SPEED) CD - 2 PUMPS 2P HH (FIX SPEED)
- Not available

HYDRONIC GROUP

Hydronic kit positioning

	Version	CD - 1 PUMP 2P BP (VAR SPEED) (4777)				CD - 1 POMPA 2P AP (VAR SPEED) (4778)				CD - 2 PUMPS 2P BP (VAR SPEED) (4782)				CD - 2 POMPE 2P AP (VAR SPEED) (4783)			
		extra L [mm]	extra W [mm]	extra H [mm]	extra WGT [kg]	extra L [mm]	extra W [mm]	extra H [mm]	extra WGT [kg]	extra L [mm]	extra W [mm]	extra H [mm]	extra WGT [kg]	extra L [mm]	extra W [mm]	extra H [mm]	extra WGT [kg]
0604		/	/	/	-	/	/	/	-	/	/	/	-	/	/	/	-
	LN	/	/	/	-	/	/	/	-	/	/	/	-	/	/	/	-
	SL	/	/	/	-	/	/	/	-	/	/	/	-	/	/	/	-
0704		/	/	/	-	/	/	/	-	/	/	/	-	/	/	/	-
	LN	/	/	/	-	/	/	/	-	/	/	/	-	/	/	/	-
	SL	/	/	/	-	/	/	/	-	/	/	/	-	/	/	/	-
0804		/	/	/	-	/	/	/	-	/	/	/	-	/	/	/	-
	LN	/	/	/	-	/	/	/	-	/	/	/	-	/	/	/	-
	SL	/	/	/	-	/	/	/	-	/	/	/	-	/	/	/	-
0904		/	/	/	-	/	/	/	-	/	/	/	-	/	/	/	-
	LN	/	/	/	-	/	/	/	-	/	/	/	-	/	/	/	-
	SL	/	/	/	-	/	/	/	-	/	/	/	-	/	/	/	-
1004		/	/	/	-	/	/	/	-	/	/	/	-	/	/	/	-
	LN	/	/	/	-	/	/	/	-	/	/	/	-	/	/	/	-
	SL	/	/	/	-	/	/	/	-	/	/	/	-	/	/	/	-
1104		/	/	/	-	/	/	/	-	/	/	/	-	/	/	/	-
	LN	/	/	/	-	/	/	/	-	/	/	/	-	/	/	/	-
	SL	/	/	/	-	/	/	/	-	/	/	/	-	/	/	/	-
1204		/	/	/	-	/	/	/	-	/	/	/	-	/	/	/	-
	LN	/	/	/	-	/	/	/	-	/	/	/	-	/	/	/	-
	SL	/	/	/	-	/	/	/	-	/	/	/	-	/	/	/	-

NOT AVAILABLE

extra L	Unit's extra length
extra W	Unit's extra operating width (NOT to be considered for transport)
extra H	Unit's extra height
extra H	Unit's extra weight (pumps and piping)
CD - 1 PUMP 2P BP (VAR SPEED)	CD - 1 PUMP 2P BP (VAR SPEED)
CD - 1 POMPA 2P AP (VAR SPEED)	CD - 1 POMPA 2P AP (VAR SPEED)
CD - 2 PUMPS 2P BP (VAR SPEED)	CD - 2 PUMPS 2P BP (VAR SPEED)
CD - 2 POMPE 2P AP (VAR SPEED)	CD - 2 POMPE 2P AP (VAR SPEED)
-	Not available

HYDRONIC GROUP

CHILLED WATER HEAT EX. USER SIDE - EV - 1 PUMP 2P HH (VAR SPEED)

SIZE		CH		HP		PUMP					CH	HP
		Pfgross	Qfgross	Ptgross	Qcdgross	Rif.	Model	N.	F.L.A.	F.L.I.	HU	HU
		[kW] (1)	[l/s] (1)	[kW] (1)	[l/s] (1)			Pole	[A]	[kW]	[kPa]	[kPa]
0604		143,9	6,880	157,2		A1	LNEE 50-160/40/2	2	8	4,000	213	
	LN	137,4	6,568	149,9							218	
	SL	136,3	6,518	149,5							219	
0704		159,6	7,631	174,3		A2	LNEE 50-160/40/2	2	8	4,000	207	
	LN	150,8	7,213	165,5							214	
	SL	153,3	7,332	167,3							212	
0804		181,2	8,667	196,8		B1	LNEE 50-160/55/2	2	11	5,500	263	
	LN	170,1	8,134	186,1							272	
	SL	176,0	8,418	192,9							267	
0904		202,6	9,689	220,1		B2	LNEE 50-160/55/2	2	11	5,500	255	
	LN	191,1	9,141	211,9							264	
	SL	192,7	9,216	212,8							263	
1004		230,4	11,02	250,5		C1	LNEE 50-160/55/2	2	11	5,500	254	
	LN	218,2	10,44	238,3							261	
	SL	216,3	10,34	237,7							262	
1104		266,0	12,72	288,0		C2	LNEE 65-160/75/2	2	14	7,500	240	
	LN	250,3	11,97	272,8							250	
	SL	250,3	11,97	276,8							250	
1204		298,3	14,27	323,3		C3	LNEE 65-160/75/2	2	14	7,500	228	
	LN	279,1	13,35	304,4							241	
	SL	282,1	13,49	310,1							239	

(1) Values refer to nominal conditions
 CH Cooling mode
 HP HP mode
 Pf Cooling capacity unit (Cooling mode)
 Pt Heating capacity unit (Heating mode)

Q Plant (side) exchanger water flow
 F.L.I. Pump power input
 F.L.A. Pump running current
 HU Pump residual pressure head (Units with hydronic group without mains filter)

CHILLED WATER HEAT EX. USER SIDE - EV - 1 PUMP 2P HH (VAR SPEED)

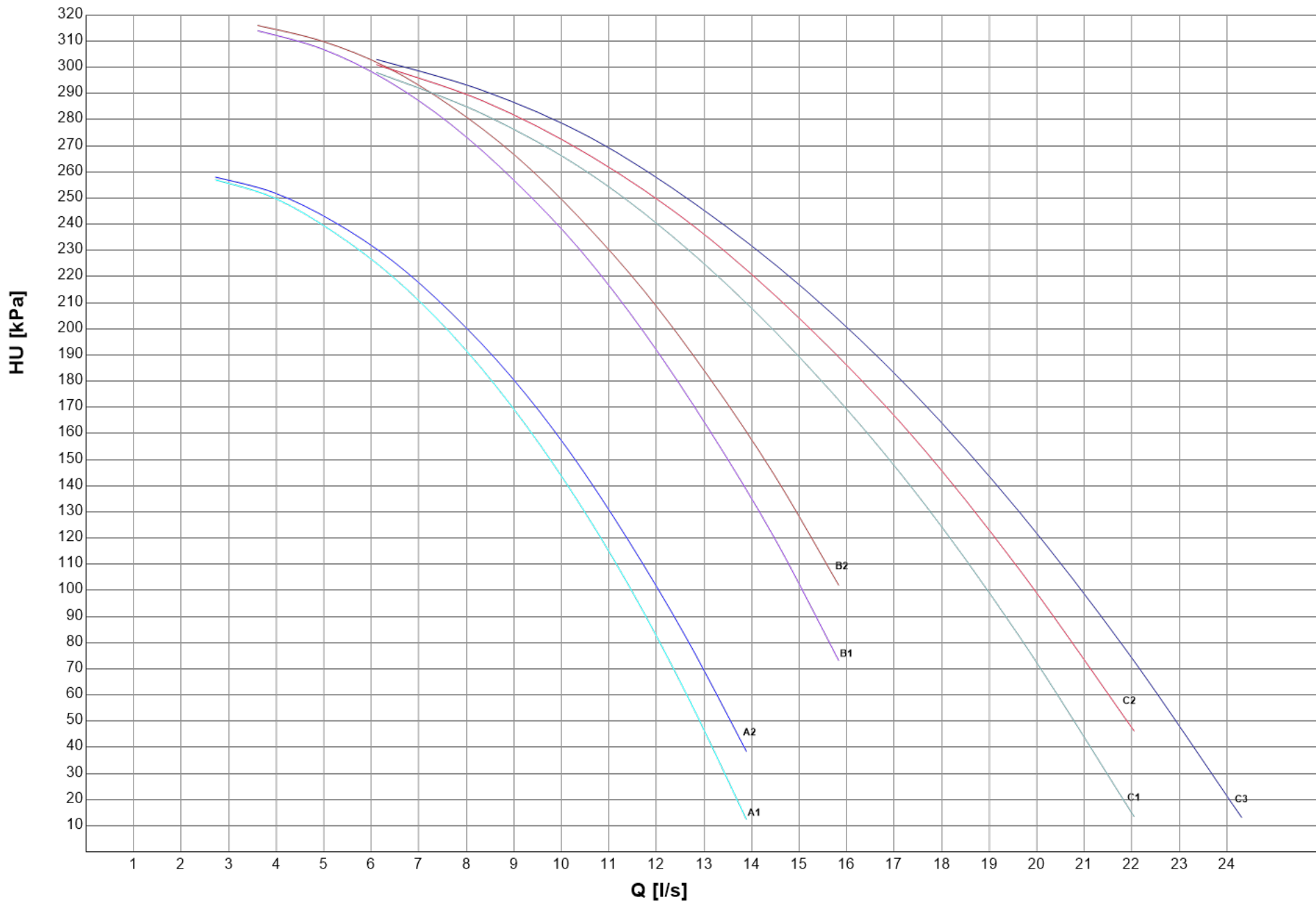

HYDRONIC GROUP

CHILLED WATER HEAT EX. USER SIDE - EV - 1 PUMP 2P HP (FIX SPEED)

SIZE		CH		HP		PUMP					CH	HP
		Pfgross	Qfgross	Ptgross	Qcdgross	Rif.	Model	N.	F.L.A.	F.L.I.	HU	HU
		[kW] (1)	[l/s] (1)	[kW] (1)	[l/s] (1)			Pole	[A]	[kW]	[kPa]	[kPa]
0604		143,9	6,880	157,2		A1	LNEE 50-160/40/2	2	8	4,000	213	
	LN	137,4	6,568	149,9							218	
	SL	136,3	6,518	149,5							219	
0704		159,6	7,631	174,3		A2	LNEE 50-160/40/2	2	8	4,000	207	
	LN	150,8	7,213	165,5							214	
	SL	153,3	7,332	167,3							212	
0804		181,2	8,667	196,8		B1	LNEE 50-160/55/2	2	11	5,500	263	
	LN	170,1	8,134	186,1							272	
	SL	176,0	8,418	192,9							267	
0904		202,6	9,689	220,1		B2	LNEE 50-160/55/2	2	11	5,500	255	
	LN	191,1	9,141	211,9							264	
	SL	192,7	9,216	212,8							263	
1004		230,4	11,02	250,5		C1	LNEE 50-160/55/2	2	11	5,500	254	
	LN	218,2	10,44	238,3							261	
	SL	216,3	10,34	237,7							262	
1104		266,0	12,72	288,0		C2	LNEE 65-160/75/2	2	14	7,500	240	
	LN	250,3	11,97	272,8							250	
	SL	250,3	11,97	276,8							250	
1204		298,3	14,27	323,3		C3	LNEE 65-160/75/2	2	14	7,500	228	
	LN	279,1	13,35	304,4							241	
	SL	282,1	13,49	310,1							239	

(1) Values refer to nominal conditions
 CH Cooling mode
 HP HP mode
 Pf Cooling capacity unit (Cooling mode)
 Pt Heating capacity unit (Heating mode)

Q Plant (side) exchanger water flow
 F.L.I. Pump power input
 F.L.A. Pump running current
 HU Pump residual pressure head (Units with hydronic group without mains filter)

CHILLED WATER HEAT EX. USER SIDE - EV - 1 PUMP 2P HP (FIX SPEED)

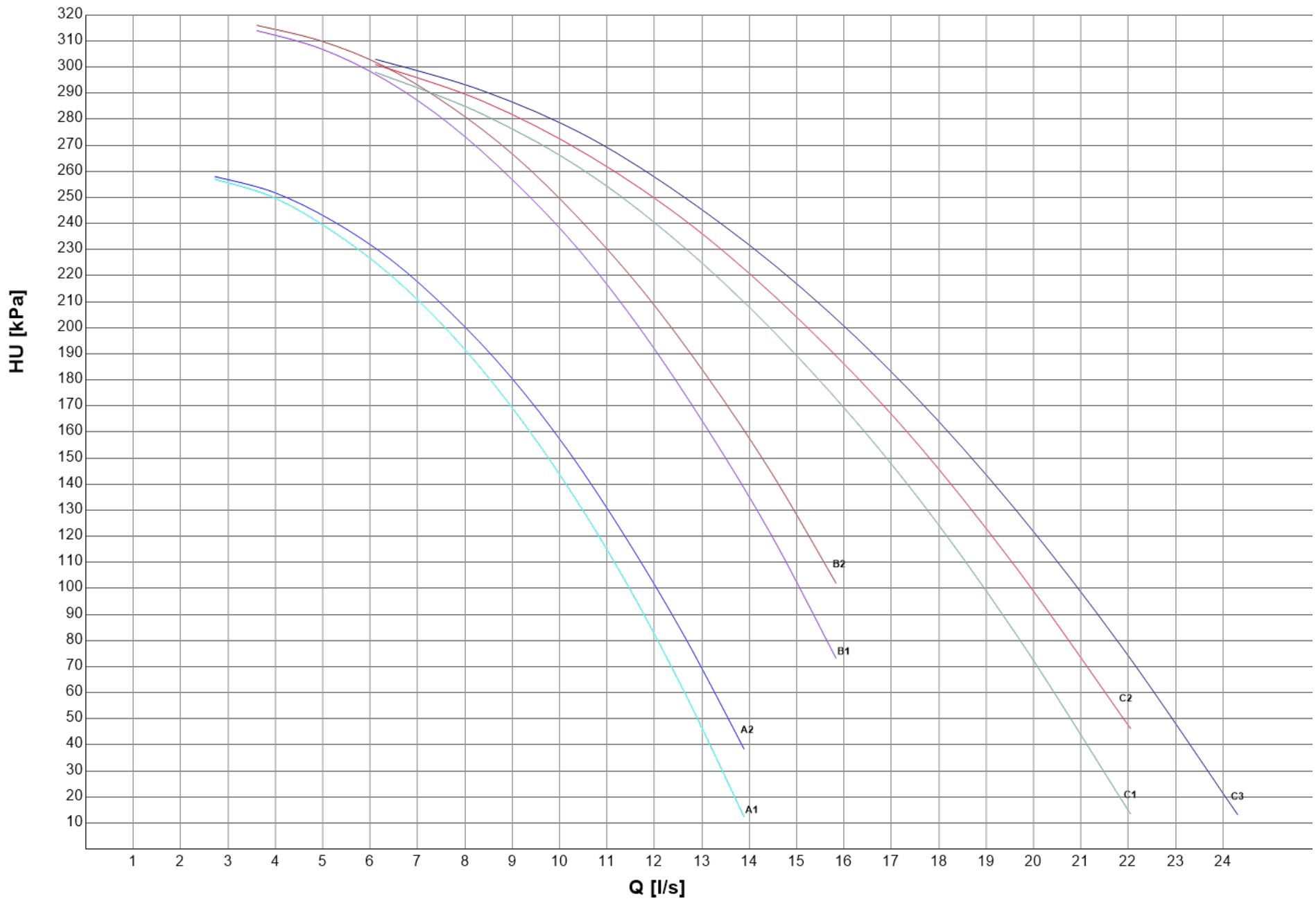

HYDRONIC GROUP

CHILLED WATER HEAT EX. USER SIDE - EV - 1 PUMP 2P LH (FIX SPEED)

SIZE		CH		HP		PUMP					CH	HP
		Pfgross	Qfgross	Ptgross	Qcdgross	Rif.	Model	N.	F.L.A.	F.L.I.	HU	HU
		[kW] (1)	[l/s] (1)	[kW] (1)	[l/s] (1)			Pole	[A]	[kW]	[kPa]	[kPa]
0604		143,9	6,880	157,2		A1	LNEE 50-125/22/2	2	5	2,200	117	
	LN	137,4	6,568	149,9							123	
	SL	136,3	6,518	149,5							124	
0704		159,6	7,631	174,3		A2	LNEE 50-125/22/2	2	5	2,200	108	
	LN	150,8	7,213	165,5							117	
	SL	153,3	7,332	167,3							114	
0804		181,2	8,667	196,8		B1	LNEE 50-125/30/2	2	6	3,000	139	
	LN	170,1	8,134	186,1							150	
	SL	176,0	8,418	192,9							144	
0904		202,6	9,689	220,1		B2	LNEE 50-125/30/2	2	6	3,000	128	
	LN	191,1	9,141	211,9							139	
	SL	192,7	9,216	212,8							138	
1004		230,4	11,02	250,5		C1	LNEE 65-125/40/2	2	8	4,000	142	
	LN	218,2	10,44	238,3							150	
	SL	216,3	10,34	237,7							151	
1104		266,0	12,72	288,0		C2	LNEE 65-125/40/2	2	8	4,000	127	
	LN	250,3	11,97	272,8							138	
	SL	250,3	11,97	276,8							138	
1204		298,3	14,27	323,3		C3	LNEE 65-125/40/2	2	8	4,000	112	
	LN	279,1	13,35	304,4							127	
	SL	282,1	13,49	310,1							125	

(1) Values refer to nominal conditions

CH Cooling mode

HP HP mode

Pf Cooling capacity unit (Cooling mode)

Pt Heating capacity unit (Heating mode)

Q Plant (side) exchanger water flow

F.L.I. Pump power input

F.L.A. Pump running current

HU Pump residual pressure head (Units with hydronic group without mains filter)

CHILLED WATER HEAT EX. USER SIDE - EV - 1 PUMP 2P LH (FIX SPEED)

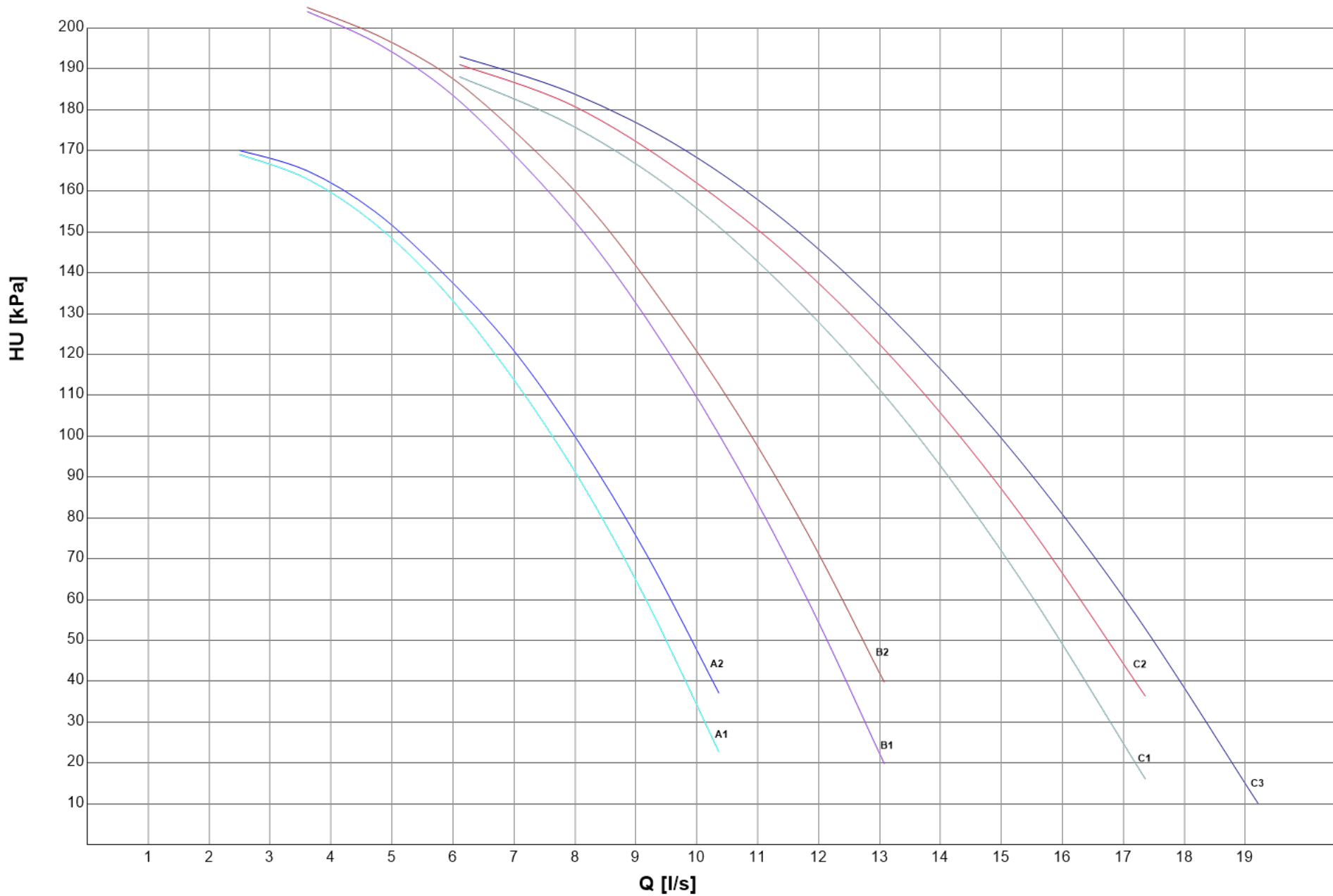

HYDRONIC GROUP

CHILLED WATER HEAT EX. USER SIDE - EV - 1 PUMP 2P LH (VAR SPEED)

SIZE		CH		HP		PUMP					CH	HP
		Pfgross	Qfgross	Ptgross	Qcdgross	Rif.	Model	N.	F.L.A.	F.L.I.	HU	HU
		[kW] (1)	[l/s] (1)	[kW] (1)	[l/s] (1)			Pole	[A]	[kW]	[kPa]	[kPa]
0604		143,9	6,880	157,2		A1	LNEE 50-125/22/2	2	5	2,200	117	
	LN	137,4	6,568	149,9							123	
	SL	136,3	6,518	149,5							124	
0704		159,6	7,631	174,3		A2	LNEE 50-125/22/2	2	5	2,200	108	
	LN	150,8	7,213	165,5							117	
	SL	153,3	7,332	167,3							114	
0804		181,2	8,667	196,8		B1	LNEE 50-125/30/2	2	6	3,000	139	
	LN	170,1	8,134	186,1							150	
	SL	176,0	8,418	192,9							144	
0904		202,6	9,689	220,1		B2	LNEE 50-125/30/2	2	6	3,000	128	
	LN	191,1	9,141	211,9							139	
	SL	192,7	9,216	212,8							138	
1004		230,4	11,02	250,5		C1	LNEE 65-125/40/2	2	8	4,000	142	
	LN	218,2	10,44	238,3							150	
	SL	216,3	10,34	237,7							151	
1104		266,0	12,72	288,0		C2	LNEE 65-125/40/2	2	8	4,000	127	
	LN	250,3	11,97	272,8							138	
	SL	250,3	11,97	276,8							138	
1204		298,3	14,27	323,3		C3	LNEE 65-125/40/2	2	8	4,000	112	
	LN	279,1	13,35	304,4							127	
	SL	282,1	13,49	310,1							125	

(1) Values refer to nominal conditions
 CH Cooling mode
 HP HP mode
 Pf Cooling capacity unit (Cooling mode)
 Pt Heating capacity unit (Heating mode)

Q Plant (side) exchanger water flow
 F.L.I. Pump power input
 F.L.A. Pump running current
 HU Pump residual pressure head (Units with hydronic group without mains filter)

CHILLED WATER HEAT EX. USER SIDE - EV - 1 PUMP 2P LH (VAR SPEED)

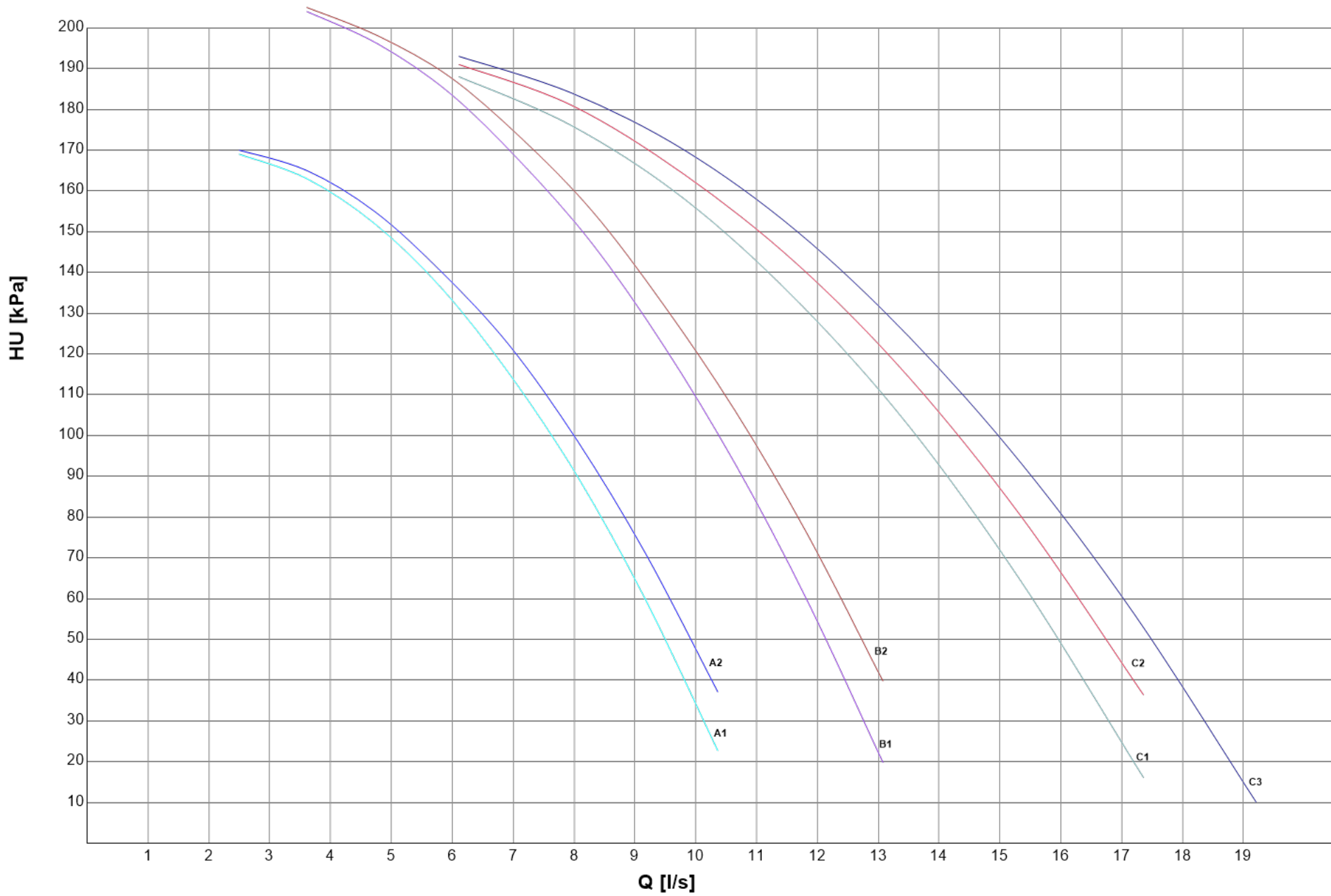

HYDRONIC GROUP

CHILLED WATER HEAT EX. USER SIDE - EV - 1 PUMP 4P LH (FIX SPEED)

SIZE		CH		HP		PUMP					CH	HP
		Pfgross	Qfgross	Ptgross	Qcdgross	Rif.	Model	N.	F.L.A.	F.L.I.	HU	HU
		[kW] (1)	[l/s] (1)	[kW] (1)	[l/s] (1)			Pole	[A]	[kW]	[kPa]	[kPa]
0604		143,9	6,880	157,2		A1	LNEE 65-250/30/4	4	7	3,000	132	
	LN	137,4	6,568	149,9							137	
	SL	136,3	6,518	149,5							138	
0704		159,6	7,631	174,3		A2	LNEE 65-250/30/4	4	7	3,000	127	
	LN	150,8	7,213	165,5							133	
	SL	153,3	7,332	167,3							132	
0804		181,2	8,667	196,8		B1	LNES 80-200/40/4	4	8	4,000	118	
	LN	170,1	8,134	186,1							125	
	SL	176,0	8,418	192,9							121	
0904		202,6	9,689	220,1		B2	LNES 80-200/40/4	4	8	4,000	116	
	LN	191,1	9,141	211,9							122	
	SL	192,7	9,216	212,8							121	
1004		230,4	11,02	250,5		C1	LNES 80-250/55/4	4	10	5,500	154	
	LN	218,2	10,44	238,3							161	
	SL	216,3	10,34	237,7							162	
1104		266,0	12,72	288,0		C2	LNES 80-250/55/4	4	10	5,500	144	
	LN	250,3	11,97	272,8							152	
	SL	250,3	11,97	276,8							152	
1204		298,3	14,27	323,3		C3	LNES 80-250/55/4	4	10	5,500	135	
	LN	279,1	13,35	304,4							146	
	SL	282,1	13,49	310,1							144	

(1) Values refer to nominal conditions
 CH Cooling mode
 HP HP mode
 Pf Cooling capacity unit (Cooling mode)
 Pt Heating capacity unit (Heating mode)

Q Plant (side) exchanger water flow
 F.L.I. Pump power input
 F.L.A. Pump running current
 HU Pump residual pressure head (Units with hydronic group without mains filter)

CHILLED WATER HEAT EX. USER SIDE - EV - 1 PUMP 4P LH (FIX SPEED)

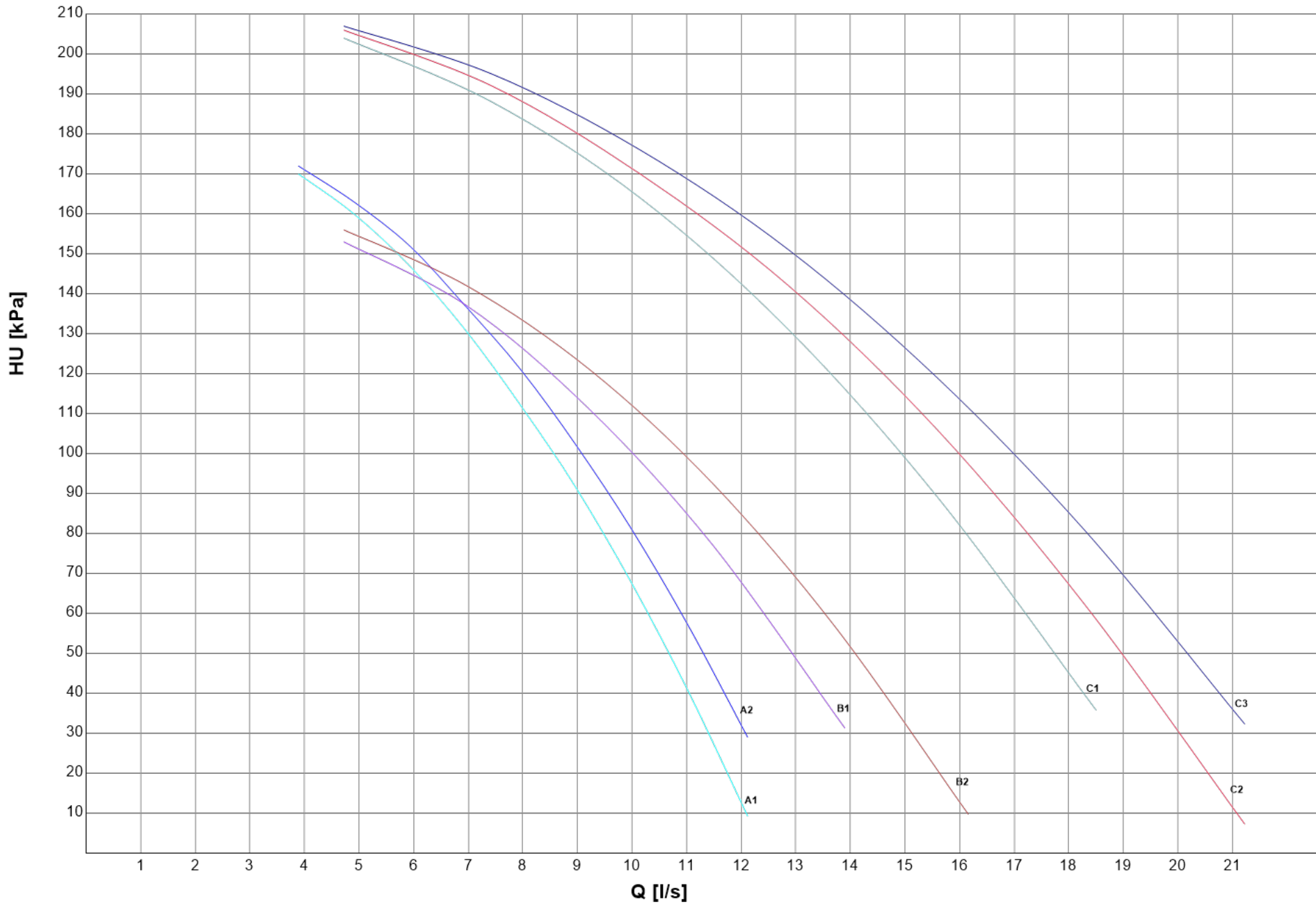

HYDRONIC GROUP

CHILLED WATER HEAT EX. USER SIDE - EV - 2 PUMPS 2P HH (VAR SPEED)

SIZE		CH		HP		PUMP					CH	HP
		Pfgross	Qfgross	Ptgross	Qcdgross	Rif.	Model	N.	F.L.A.	F.L.I.	HU	HU
		[kW] (1)	[l/s] (1)	[kW] (1)	[l/s] (1)			Pole	[A]	[kW]	[kPa]	[kPa]
0604		143,9	6,880	157,2		A1	LNTE 50-160/40/2	2	8	4,000	212	
	LN	137,4	6,568	149,9							218	
	SL	136,3	6,518	149,5							218	
0704		159,6	7,631	174,3		A2	LNTE 50-160/40/2	2	8	4,000	204	
	LN	150,8	7,213	165,5							212	
	SL	153,3	7,332	167,3							210	
0804		181,2	8,667	196,8		B1	LNTE 50-160/55/2	2	11	5,500	264	
	LN	170,1	8,134	186,1							274	
	SL	176,0	8,418	192,9							269	
0904		202,6	9,689	220,1		B2	LNTE 50-160/55/2	2	11	5,500	254	
	LN	191,1	9,141	211,9							265	
	SL	192,7	9,216	212,8							263	
1004		230,4	11,02	250,5		C1	LNTE 50-160/55/2	2	11	5,500	239	
	LN	218,2	10,44	238,3							247	
	SL	216,3	10,34	237,7							249	
1104		266,0	12,72	288,0		C2	LNTE 65-160/75/2	2	14	7,500	223	
	LN	250,3	11,97	272,8							235	
	SL	250,3	11,97	276,8							235	
1204		298,3	14,27	323,3		C3	LNTE 65-160/75/2	2	14	7,500	209	
	LN	279,1	13,35	304,4							224	
	SL	282,1	13,49	310,1							221	

(1) Values refer to nominal conditions
 CH Cooling mode
 HP HP mode
 Pf Cooling capacity unit (Cooling mode)
 Pt Heating capacity unit (Heating mode)

Q Plant (side) exchanger water flow
 F.L.I. Pump power input
 F.L.A. Pump running current
 HU Pump residual pressure head (Units with hydronic group without mains filter)

CHILLED WATER HEAT EX. USER SIDE - EV - 2 PUMPS 2P HH (VAR SPEED)

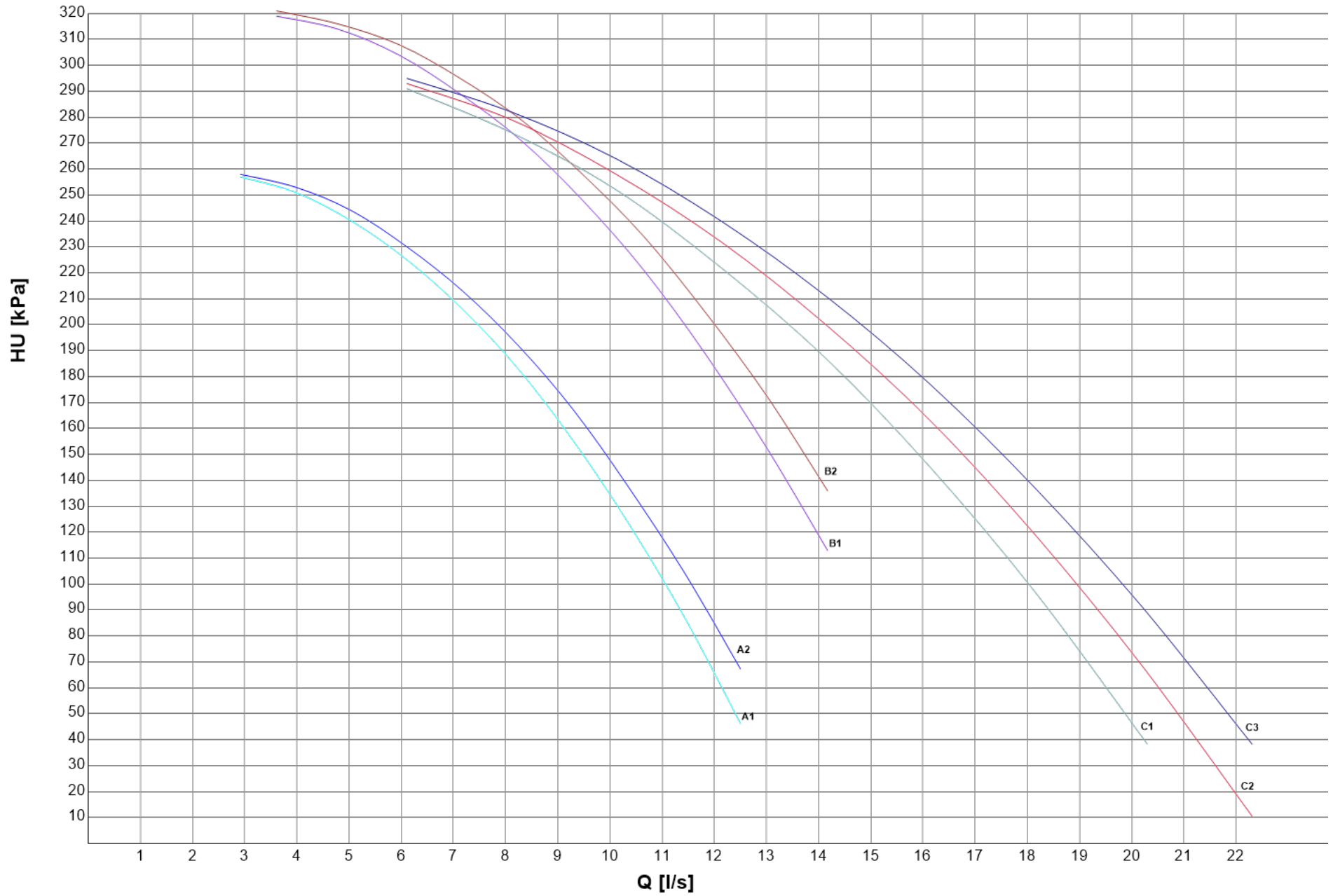

HYDRONIC GROUP

CHILLED WATER HEAT EX. USER SIDE - EV - 2 PUMPS 2P HP (FIX SPEED)

SIZE		CH		HP		PUMP					CH	HP
		Pfgross	Qfgross	Ptgross	Qcdgross	Rif.	Model	N.	F.L.A.	F.L.I.	HU	HU
		[kW] (1)	[l/s] (1)	[kW] (1)	[l/s] (1)			Pole	[A]	[kW]	[kPa]	[kPa]
0604		143,9	6,880	157,2		A1	LNTE 50-160/40/2	2	8	4,000	212	
	LN	137,4	6,568	149,9							218	
	SL	136,3	6,518	149,5							218	
0704		159,6	7,631	174,3		A2	LNTE 50-160/40/2	2	8	4,000	204	
	LN	150,8	7,213	165,5							212	
	SL	153,3	7,332	167,3							210	
0804		181,2	8,667	196,8		B1	LNTE 50-160/55/2	2	11	5,500	264	
	LN	170,1	8,134	186,1							274	
	SL	176,0	8,418	192,9							269	
0904		202,6	9,689	220,1		B2	LNTE 50-160/55/2	2	11	5,500	254	
	LN	191,1	9,141	211,9							265	
	SL	192,7	9,216	212,8							263	
1004		230,4	11,02	250,5		C1	LNTE 50-160/55/2	2	11	5,500	239	
	LN	218,2	10,44	238,3							247	
	SL	216,3	10,34	237,7							249	
1104		266,0	12,72	288,0		C2	LNTE 65-160/75/2	2	14	7,500	223	
	LN	250,3	11,97	272,8							235	
	SL	250,3	11,97	276,8							235	
1204		298,3	14,27	323,3		C3	LNTE 65-160/75/2	2	14	7,500	209	
	LN	279,1	13,35	304,4							224	
	SL	282,1	13,49	310,1							221	

(1) Values refer to nominal conditions
 CH Cooling mode
 HP HP mode
 Pf Cooling capacity unit (Cooling mode)
 Pt Heating capacity unit (Heating mode)

Q Plant (side) exchanger water flow
 F.L.I. Pump power input
 F.L.A. Pump running current
 HU Pump residual pressure head (Units with hydronic group without mains filter)

CHILLED WATER HEAT EX. USER SIDE - EV - 2 PUMPS 2P HP (FIX SPEED)

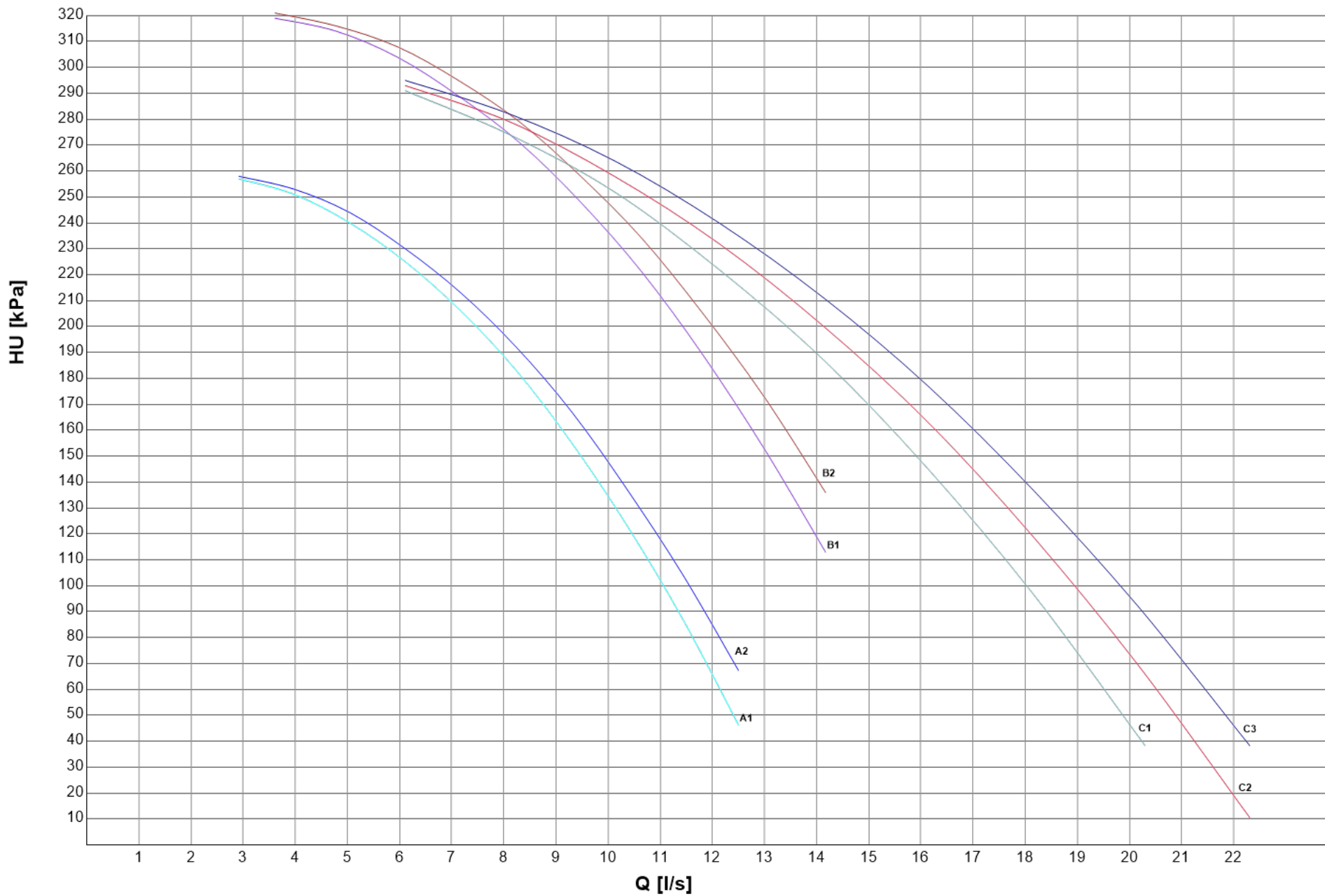

HYDRONIC GROUP

CHILLED WATER HEAT EX. USER SIDE - EV - 2 PUMPS 2P LH (FIX SPEED)

SIZE		CH		HP		PUMP					CH	HP
		Pfgross	Qfgross	Ptgross	Qcdgross	Rif.	Model	N.	F.L.A.	F.L.I.	HU	HU
		[kW] (1)	[l/s] (1)	[kW] (1)	[l/s] (1)			Pole	[A]	[kW]	[kPa]	[kPa]
0604		143,9	6,880	157,2		A1	LNTE 50-125/22/2	2	5	2,200	106	
	LN	137,4	6,568	149,9							112	
	SL	136,3	6,518	149,5							113	
0704		159,6	7,631	174,3		B1	LNTE 50-125/30/2	2	6	3,000	139	
	LN	150,8	7,213	165,5							147	
	SL	153,3	7,332	167,3							145	
0804		181,2	8,667	196,8		B2	LNTE 50-125/30/2	2	6	3,000	126	
	LN	170,1	8,134	186,1							137	
	SL	176,0	8,418	192,9							131	
0904		202,6	9,689	220,1		C1	LNTE 65-125/30/2	2	6	3,000	111	
	LN	191,1	9,141	211,9							119	
	SL	192,7	9,216	212,8							118	
1004		230,4	11,02	250,5		D1	LNTE 65-125/40/2	2	8	4,000	135	
	LN	218,2	10,44	238,3							144	
	SL	216,3	10,34	237,7							145	
1104		266,0	12,72	288,0		D2	LNTE 65-125/40/2	2	8	4,000	119	
	LN	250,3	11,97	272,8							130	
	SL	250,3	11,97	276,8							130	
1204		298,3	14,27	323,3		D3	LNTE 65-125/40/2	2	8	4,000	104	
	LN	279,1	13,35	304,4							118	
	SL	282,1	13,49	310,1							116	

(1) Values refer to nominal conditions
 CH Cooling mode
 HP HP mode
 Pf Cooling capacity unit (Cooling mode)
 Pt Heating capacity unit (Heating mode)

Q Plant (side) exchanger water flow
 F.L.I. Pump power input
 F.L.A. Pump running current
 HU Pump residual pressure head (Units with hydronic group without mains filter)

CHILLED WATER HEAT EX. USER SIDE - EV - 2 PUMPS 2P LH (FIX SPEED)

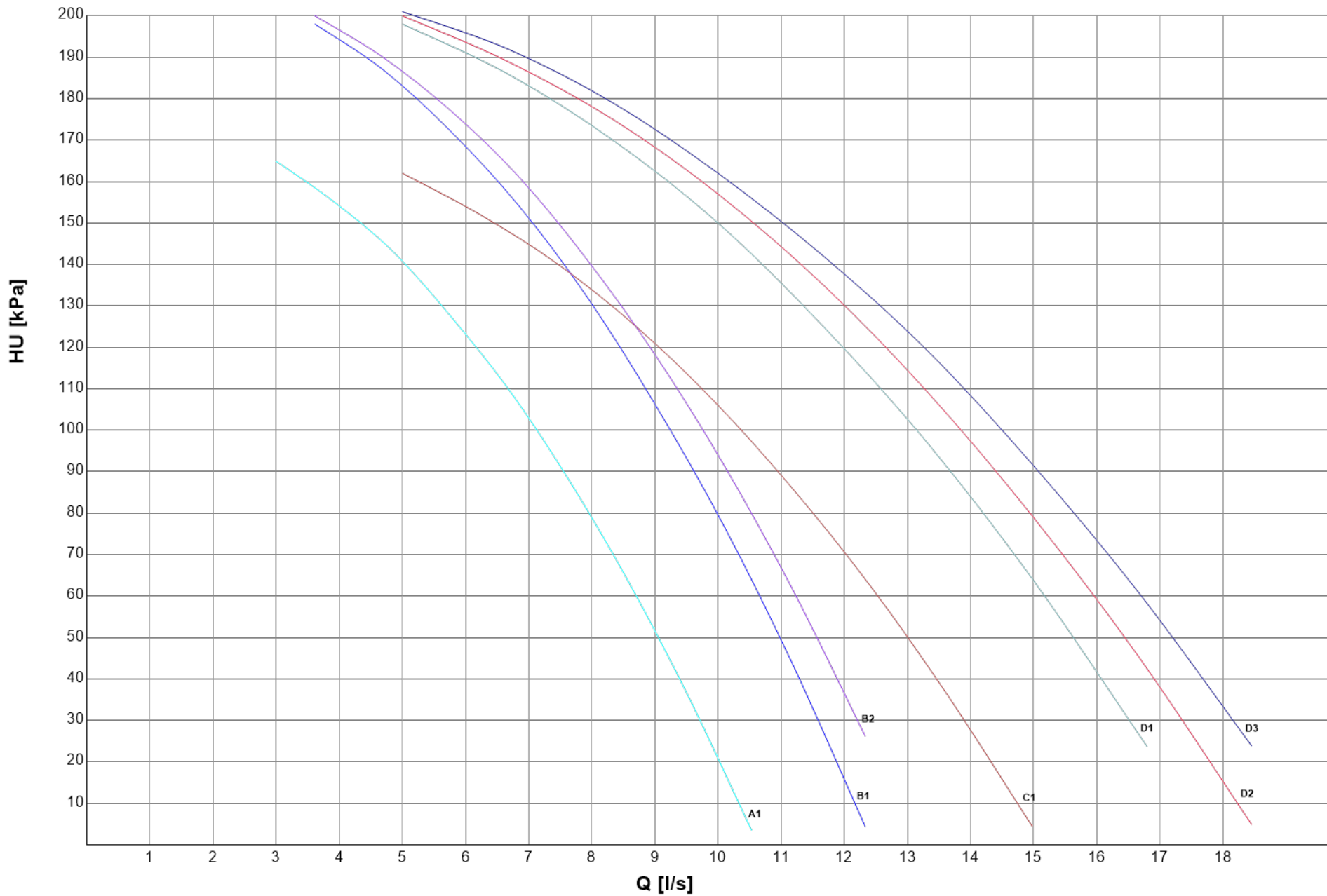

HYDRONIC GROUP

CHILLED WATER HEAT EX. USER SIDE - EV - 2 PUMPS 2P LH (VAR SPEED)

SIZE		CH		HP		PUMP					CH	HP
		Pfgross	Qfgross	Ptgross	Qcdgross	Rif.	Model	N.	F.L.A.	F.L.I.	HU	HU
		[kW] (1)	[l/s] (1)	[kW] (1)	[l/s] (1)			Pole	[A]	[kW]	[kPa]	[kPa]
0604		143,9	6,880	157,2		A1	LNTE 50-125/22/2	2	5	2,200	106	
	LN	137,4	6,568	149,9							112	
	SL	136,3	6,518	149,5							113	
0704		159,6	7,631	174,3		B1	LNTE 50-125/30/2	2	6	3,000	139	
	LN	150,8	7,213	165,5							147	
	SL	153,3	7,332	167,3							145	
0804		181,2	8,667	196,8		B2	LNTE 50-125/30/2	2	6	3,000	126	
	LN	170,1	8,134	186,1							137	
	SL	176,0	8,418	192,9							131	
0904		202,6	9,689	220,1		C1	LNTE 65-125/30/2	2	6	3,000	111	
	LN	191,1	9,141	211,9							119	
	SL	192,7	9,216	212,8							118	
1004		230,4	11,02	250,5		D1	LNTE 65-125/40/2	2	8	4,000	135	
	LN	218,2	10,44	238,3							144	
	SL	216,3	10,34	237,7							145	
1104		266,0	12,72	288,0		D2	LNTE 65-125/40/2	2	8	4,000	119	
	LN	250,3	11,97	272,8							130	
	SL	250,3	11,97	276,8							130	
1204		298,3	14,27	323,3		D3	LNTE 65-125/40/2	2	8	4,000	104	
	LN	279,1	13,35	304,4							118	
	SL	282,1	13,49	310,1							116	

(1) Values refer to nominal conditions

CH Cooling mode

HP HP mode

Pf Cooling capacity unit (Cooling mode)

Pt Heating capacity unit (Heating mode)

Q Plant (side) exchanger water flow

F.L.I. Pump power input

F.L.A. Pump running current

HU Pump residual pressure head (Units with hydronic group without mains filter)

CHILLED WATER HEAT EX. USER SIDE - EV - 2 PUMPS 2P LH (VAR SPEED)

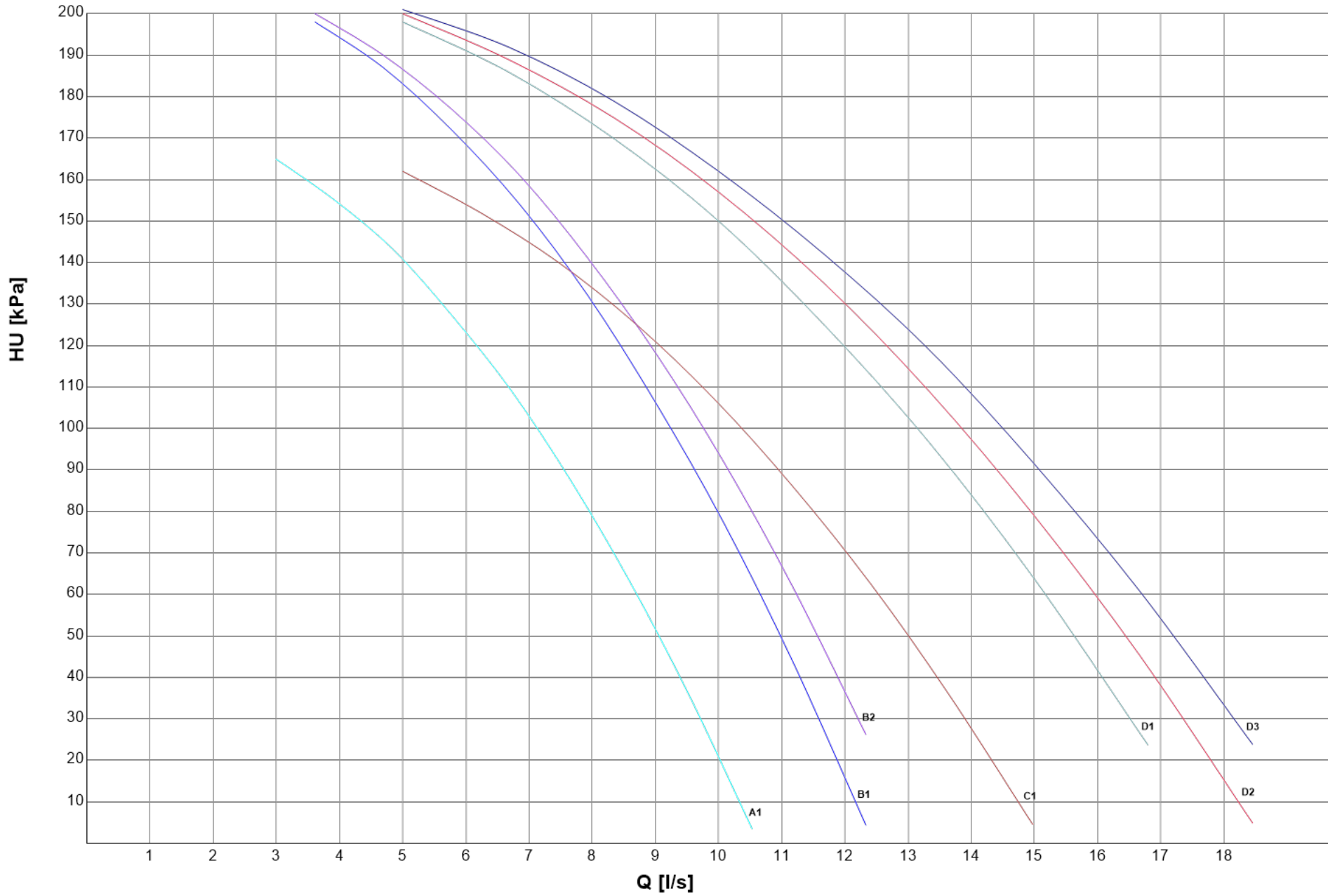

HYDRONIC GROUP

CHILLED WATER HEAT EX. USER SIDE - EV - 2 PUMPS 4P LH (FIX SPEED)

SIZE		CH		HP		PUMP					CH	HP
		Pfgross	Qfgross	Ptgross	Qcdgross	Rif.	Model	N.	F.L.A.	F.L.I.	HU	HU
		[kW] (1)	[l/s] (1)	[kW] (1)	[l/s] (1)			Pole	[A]	[kW]	[kPa]	[kPa]
0604		143,9	6,880	157,2		A1	LNTE 65-250/30/4	4	7	3,000	126	
	LN	137,4	6,568	149,9							131	
	SL	136,3	6,518	149,5							132	
0704		159,6	7,631	174,3		A2	LNTE 65-250/30/4	4	7	3,000	120	
	LN	150,8	7,213	165,5							127	
	SL	153,3	7,332	167,3							125	
0804		181,2	8,667	196,8		A3	LNTE 65-250/30/4	4	7	3,000	111	
	LN	170,1	8,134	186,1							120	
	SL	176,0	8,418	192,9							116	
0904		202,6	9,689	220,1		B1	LNTE 65-250/30/4	4	7	3,000	112	
	LN	191,1	9,141	211,9							118	
	SL	192,7	9,216	212,8							117	
1004		230,4	11,02	250,5		C1	LNTE 65-250/30/4	4	7	3,000	149	
	LN	218,2	10,44	238,3							155	
	SL	216,3	10,34	237,7							156	
1104		266,0	12,72	288,0		C2	LNTE 65-250/30/4	4	7	3,000	138	
	LN	250,3	11,97	272,8							147	
	SL	250,3	11,97	276,8							147	
1204		298,3	14,27	323,3		C3	LNTE 65-250/30/4	4	7	3,000	130	
	LN	279,1	13,35	304,4							141	
	SL	282,1	13,49	310,1							139	

(1) Values refer to nominal conditions
 CH Cooling mode
 HP HP mode
 Pf Cooling capacity unit (Cooling mode)
 Pt Heating capacity unit (Heating mode)

Q Plant (side) exchanger water flow
 F.L.I. Pump power input
 F.L.A. Pump running current
 HU Pump residual pressure head (Units with hydronic group without mains filter)

CHILLED WATER HEAT EX. USER SIDE - EV - 2 PUMPS 4P LH (FIX SPEED)

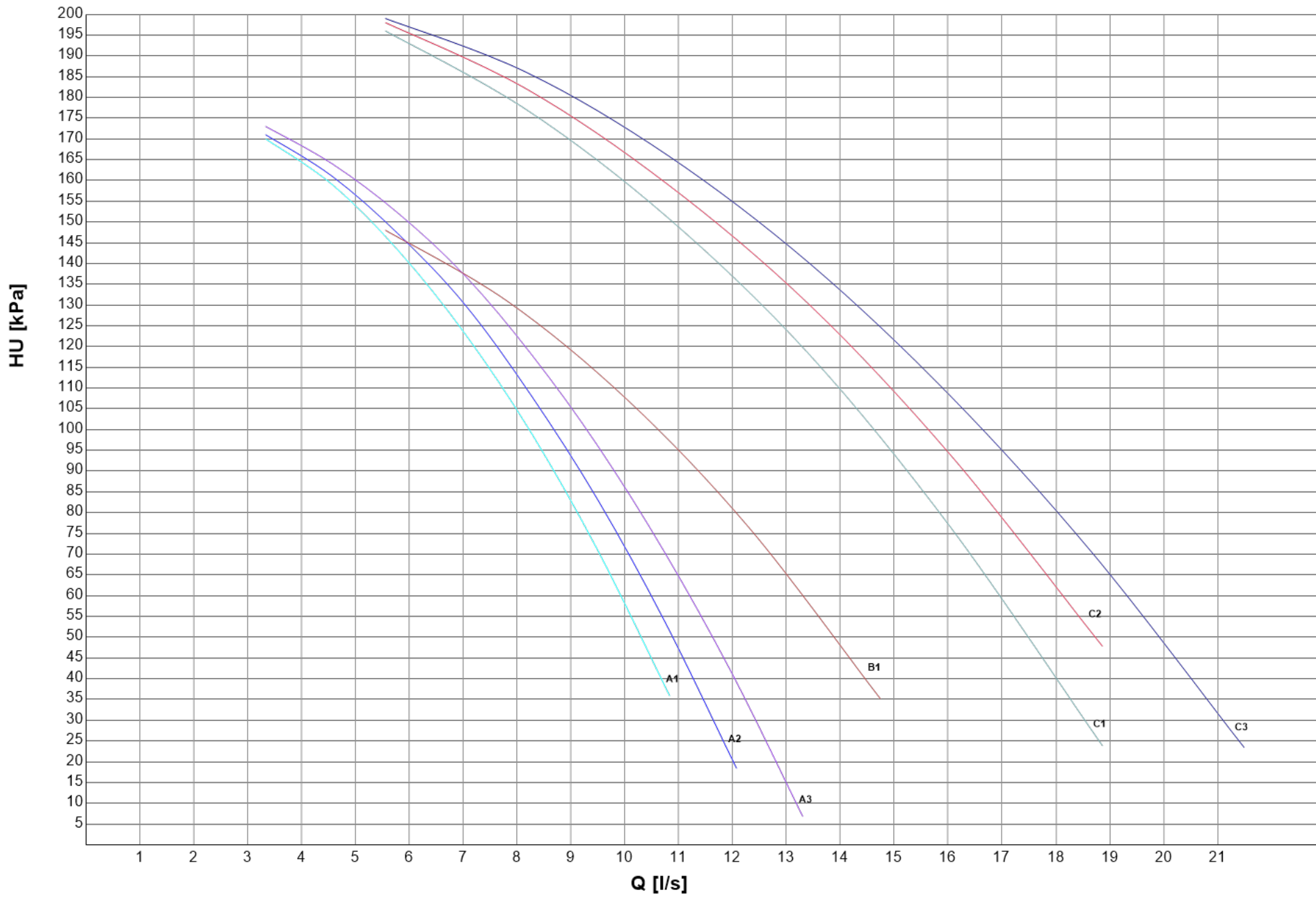

HYDRONIC GROUP

WARM WATER HEAT EX. USER SIDE - CD - 1 POMPA 2P AP (VAR SPEED)

SIZE	CH		HP		PUMP					CH	HP	
	Pfgross	Qfgross	Ptgross	Qcdgross	Rif.	Model	N.	F.L.A.	F.L.I.	HU	HU	
	[kW] (1)	[l/s] (1)	[kW] (1)	[l/s] (1)			Pole	[A]	[kW]	[kPa]	[kPa]	
0604		143,9		157,2	7,589	A1	LNEE 50-160/40/2	2	8	4,000		197
	LN	137,4		149,9	7,238							204
	SL	136,3		149,5	7,214							204
0704		159,6		174,3	8,413	A2	LNEE 50-160/40/2	2	8	4,000		188
	LN	150,8		165,5	7,988							197
	SL	153,3		167,3	8,075							195
0804		181,2		196,8	9,498	B1	LNEE 50-160/55/2	2	11	5,500		242
	LN	170,1		186,1	8,982							252
	SL	176,0		192,9	9,312							246
0904		202,6		220,1	10,63	B2	LNEE 50-160/55/2	2	11	5,500		231
	LN	191,1		211,9	10,23							239
	SL	192,7		212,8	10,27							238
1004		230,4		250,5	12,09	C1	LNEE 65-160/75/2	2	14	7,500		229
	LN	218,2		238,3	11,50							238
	SL	216,3		237,7	11,47							239
1104		266,0		288,0	13,90	C2	LNEE 65-160/75/2	2	14	7,500		216
	LN	250,3		272,8	13,17							228
	SL	250,3		276,8	13,36							225
1204		298,3		323,3	15,60	C3	LNEE 65-160/75/2	2	14	7,500		200
	LN	279,1		304,4	14,70							215
	SL	282,1		310,1	14,97							210

(1) Values refer to nominal conditions

CH Cooling mode

HP HP mode

Pf Cooling capacity unit (Cooling mode)

Pt Heating capacity unit (Heating mode)

Q Plant (side) exchanger water flow

F.L.I. Pump power input

F.L.A. Pump running current

HU Pump residual pressure head (Units with hydronic group without mains filter)

WARM WATER HEAT EX. USER SIDE - CD - 1 POMPA 2P AP (VAR SPEED)

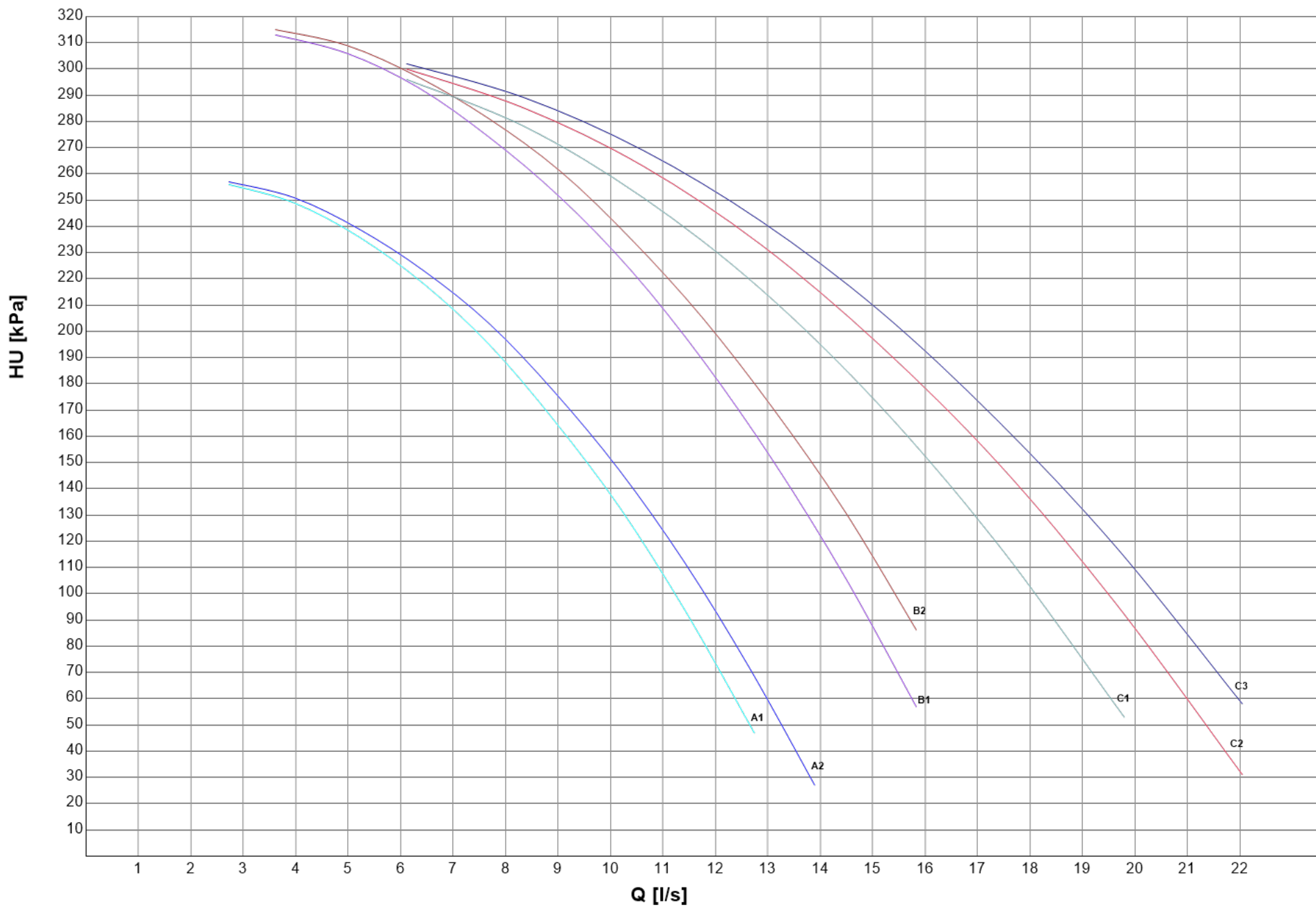

HYDRONIC GROUP

WARM WATER HEAT EX. USER SIDE - CD - 1 PUMP 2P BP (VAR SPEED)

SIZE	CH		HP		PUMP					CH	HP	
	Pfgross	Qfgross	Ptgross	Qcdgross	Rif.	Model	N.	F.L.A.	F.L.I.	HU	HU	
	[kW] (1)	[l/s] (1)	[kW] (1)	[l/s] (1)			Pole	[A]	[kW]	[kPa]	[kPa]	
0604		143,9		157,2	7,589	A1	LNEE 50-125/22/2	2	5	2,200		97,8
	LN	137,4		149,9	7,238							106
	SL	136,3		149,5	7,214							106
0704		159,6		174,3	8,413	A2	LNEE 50-125/22/2	2	5	2,200		86,2
	LN	150,8		165,5	7,988							96,5
	SL	153,3		167,3	8,075							94,4
0804		181,2		196,8	9,498	B1	LNEE 50-125/30/2	2	6	3,000		116
	LN	170,1		186,1	8,982							128
	SL	176,0		192,9	9,312							120
0904		202,6		220,1	10,63	B2	LNEE 50-125/30/2	2	6	3,000		99,5
	LN	191,1		211,9	10,23							109
	SL	192,7		212,8	10,27							108
1004		230,4		250,5	12,09	C1	LNEE 65-125/40/2	2	8	4,000		117
	LN	218,2		238,3	11,50							127
	SL	216,3		237,7	11,47							127
1104		266,0		288,0	13,90	C2	LNEE 65-125/40/2	2	8	4,000		101
	LN	250,3		272,8	13,17							114
	SL	250,3		276,8	13,36							111
1204		298,3		323,3	15,60	C3	LNEE 65-125/40/2	2	8	4,000		80,9
	LN	279,1		304,4	14,70							98,2
	SL	282,1		310,1	14,97							93,1

(1) Values refer to nominal conditions
 CH Cooling mode
 HP HP mode
 Pf Cooling capacity unit (Cooling mode)
 Pt Heating capacity unit (Heating mode)

Q Plant (side) exchanger water flow
 F.L.I. Pump power input
 F.L.A. Pump running current
 HU Pump residual pressure head (Units with hydronic group without mains filter)

WARM WATER HEAT EX. USER SIDE - CD - 1 PUMP 2P BP (VAR SPEED)

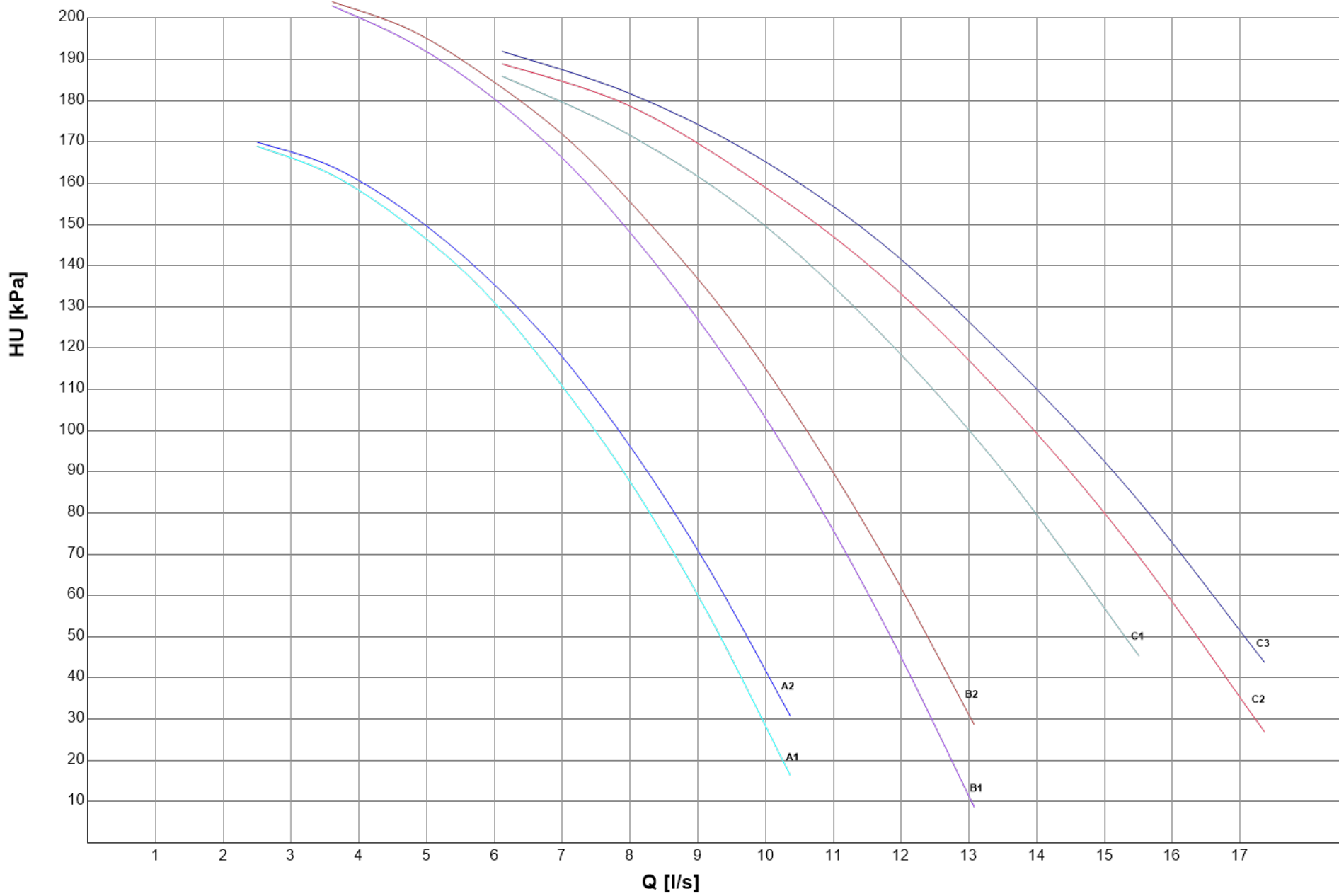

HYDRONIC GROUP

WARM WATER HEAT EX. USER SIDE - CD - 1 PUMP 2P HH (FIX SPEED)

SIZE		CH		HP		PUMP				CH	HP	
		Pfgross	Qfgross	Ptgross	Qcdgross	Rif.	Model	N.	F.L.A.	F.L.I.	HU	HU
		[kW] (1)	[l/s] (1)	[kW] (1)	[l/s] (1)			Pole	[A]	[kW]	[kPa]	[kPa]
0604		143,9		157,2	7,589	A1	LNEE 50-160/40/2	2	8	4,000		197
	LN	137,4		149,9	7,238							204
	SL	136,3		149,5	7,214							204
0704		159,6		174,3	8,413	A2	LNEE 50-160/40/2	2	8	4,000		188
	LN	150,8		165,5	7,988							197
	SL	153,3		167,3	8,075							195
0804		181,2		196,8	9,498	B1	LNEE 50-160/55/2	2	11	5,500		242
	LN	170,1		186,1	8,982							252
	SL	176,0		192,9	9,312							246
0904		202,6		220,1	10,63	B2	LNEE 50-160/55/2	2	11	5,500		231
	LN	191,1		211,9	10,23							239
	SL	192,7		212,8	10,27							238
1004		230,4		250,5	12,09	C1	LNEE 65-160/75/2	2	14	7,500		229
	LN	218,2		238,3	11,50							238
	SL	216,3		237,7	11,47							239
1104		266,0		288,0	13,90	C2	LNEE 65-160/75/2	2	14	7,500		216
	LN	250,3		272,8	13,17							228
	SL	250,3		276,8	13,36							225
1204		298,3		323,3	15,60	C3	LNEE 65-160/75/2	2	14	7,500		200
	LN	279,1		304,4	14,70							215
	SL	282,1		310,1	14,97							210

(1) Values refer to nominal conditions
 CH Cooling mode
 HP HP mode
 Pf Cooling capacity unit (Cooling mode)
 Pt Heating capacity unit (Heating mode)

Q Plant (side) exchanger water flow
 F.L.I. Pump power input
 F.L.A. Pump running current
 HU Pump residual pressure head (Units with hydronic group without mains filter)

WARM WATER HEAT EX. USER SIDE - CD - 1 PUMP 2P HH (FIX SPEED)

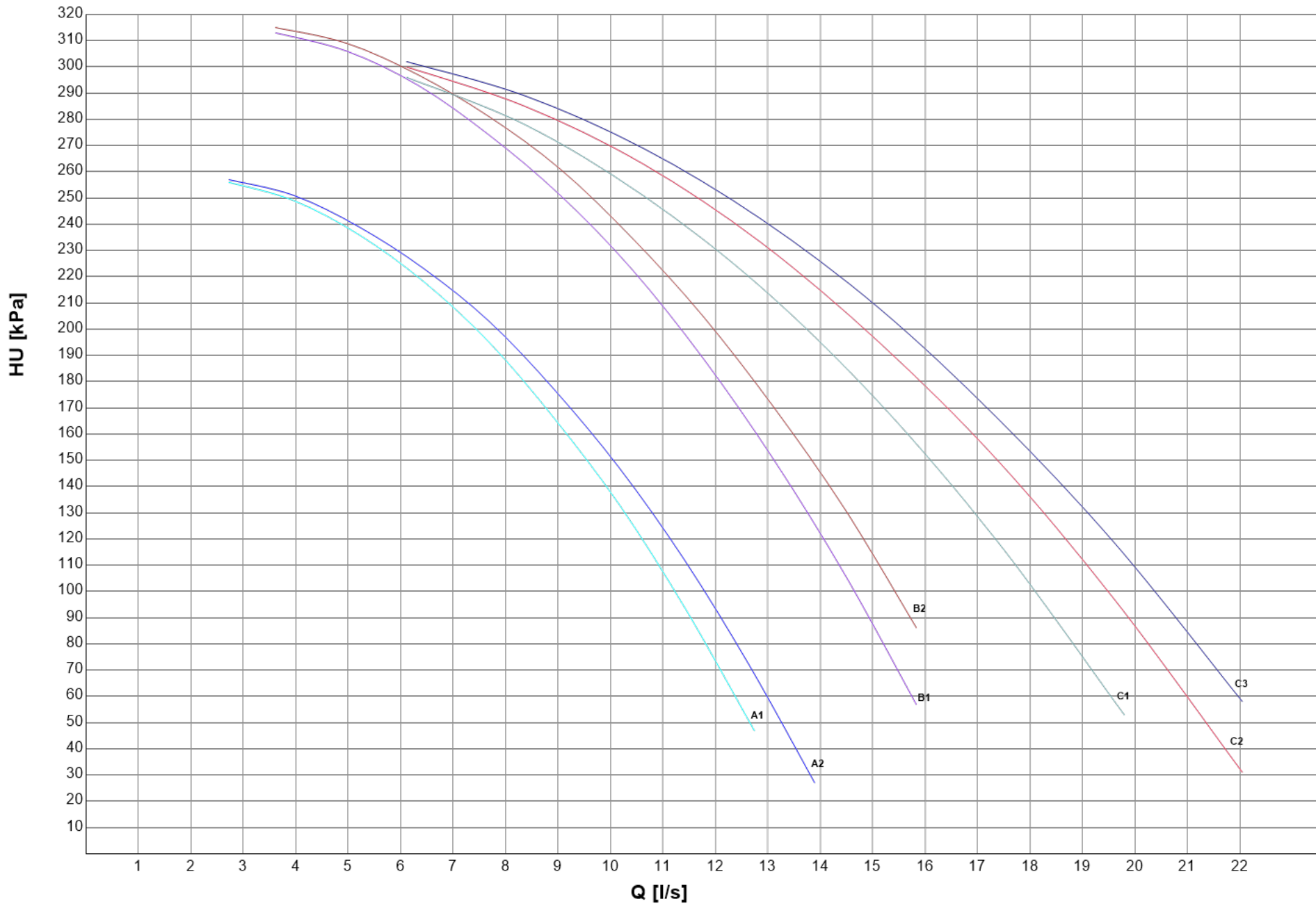

HYDRONIC GROUP

WARM WATER HEAT EX. USER SIDE - CD - 1 PUMP 2P LH (FIX SPEED)

SIZE	CH		HP		PUMP					CH	HP
	Pfgross	Qfgross	Ptgross	Qcdgross	Rif.	Model	N.	F.L.A.	F.L.I.	HU	HU
	[kW] (1)	[l/s] (1)	[kW] (1)	[l/s] (1)			Pole	[A]	[kW]	[kPa]	[kPa]
0604		143,9		157,2	A1	LNEE 50-125/22/2	2	5	2,200		97,8
	LN	137,4		149,9						106	
	SL	136,3		149,5						106	
0704		159,6		174,3	A2	LNEE 50-125/22/2	2	5	2,200		86,2
	LN	150,8		165,5						96,5	
	SL	153,3		167,3						94,4	
0804		181,2		196,8	B1	LNEE 50-125/30/2	2	6	3,000		116
	LN	170,1		186,1						128	
	SL	176,0		192,9						120	
0904		202,6		220,1	B2	LNEE 50-125/30/2	2	6	3,000		99,5
	LN	191,1		211,9						109	
	SL	192,7		212,8						108	
1004		230,4		250,5	C1	LNEE 65-125/40/2	2	8	4,000		117
	LN	218,2		238,3						127	
	SL	216,3		237,7						127	
1104		266,0		288,0	C2	LNEE 65-125/40/2	2	8	4,000		101
	LN	250,3		272,8						114	
	SL	250,3		276,8						111	
1204		298,3		323,3	C3	LNEE 65-125/40/2	2	8	4,000		80,9
	LN	279,1		304,4						98,2	
	SL	282,1		310,1						93,1	

(1) Values refer to nominal conditions

CH Cooling mode

HP HP mode

Pf Cooling capacity unit (Cooling mode)

Pt Heating capacity unit (Heating mode)

Q Plant (side) exchanger water flow

F.L.I. Pump power input

F.L.A. Pump running current

HU Pump residual pressure head (Units with hydronic group without mains filter)

WARM WATER HEAT EX. USER SIDE - CD - 1 PUMP 2P LH (FIX SPEED)

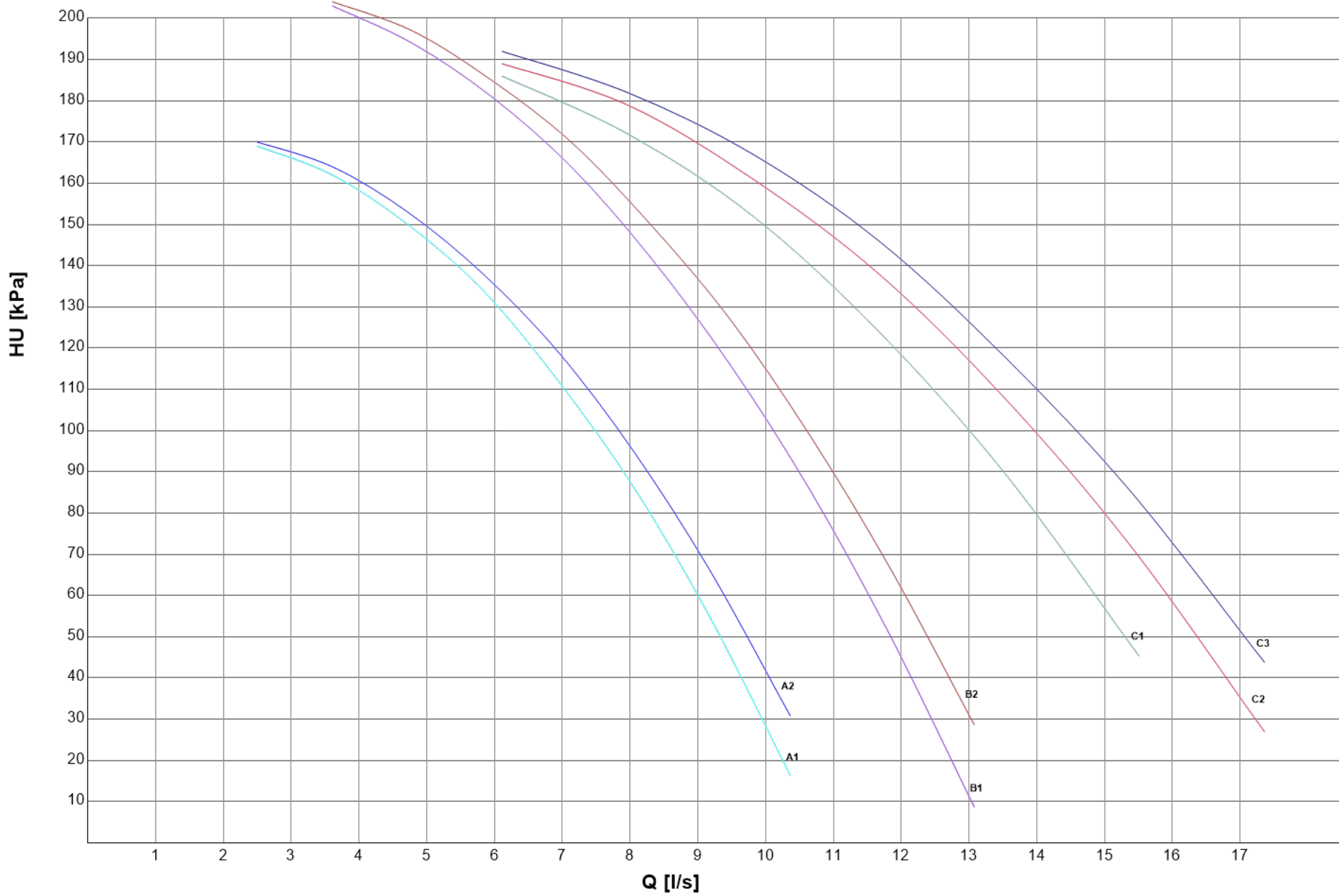

HYDRONIC GROUP

WARM WATER HEAT EX. USER SIDE - CD - 1 PUMP 4P LH (FIX SPEED)

SIZE	CH		HP		PUMP					CH	HP	
	Pfgross	Qfgross	Ptgross	Qcdgross	Rif.	Model	N.	F.L.A.	F.L.I.	HU	HU	
	[kW] (1)	[l/s] (1)	[kW] (1)	[l/s] (1)			Pole	[A]	[kW]	[kPa]	[kPa]	
0604		143,9		157,2	7,589	A1	LN SL	4	7	3,000		116
	LN	137,4		149,9	7,238							123
	SL	136,3		149,5	7,214							123
0704		159,6		174,3	8,413	A2	LN SL	4	7	3,000		109
	LN	150,8		165,5	7,988							117
	SL	153,3		167,3	8,075							115
0804		181,2		196,8	9,498	B1	LN SL	4	8	4,000		102
	LN	170,1		186,1	8,982							109
	SL	176,0		192,9	9,312							104
0904		202,6		220,1	10,63	B2	LN SL	4	8	4,000		96,9
	LN	191,1		211,9	10,23							103
	SL	192,7		212,8	10,27							102
1004		230,4		250,5	12,09	C1	LN SL	4	10	5,500		131
	LN	218,2		238,3	11,50							140
	SL	216,3		237,7	11,47							140
1104		266,0		288,0	13,90	C2	LN SL	4	10	5,500		123
	LN	250,3		272,8	13,17							133
	SL	250,3		276,8	13,36							130
1204		298,3		323,3	15,60	C3	LN SL	4	10	5,500		111
	LN	279,1		304,4	14,70							124
	SL	282,1		310,1	14,97							120

(1) Values refer to nominal conditions
 CH Cooling mode
 HP HP mode
 Pf Cooling capacity unit (Cooling mode)
 Pt Heating capacity unit (Heating mode)

Q Plant (side) exchanger water flow
 F.L.I. Pump power input
 F.L.A. Pump running current
 HU Pump residual pressure head (Units with hydronic group without mains filter)

WARM WATER HEAT EX. USER SIDE - CD - 1 PUMP 4P LH (FIX SPEED)

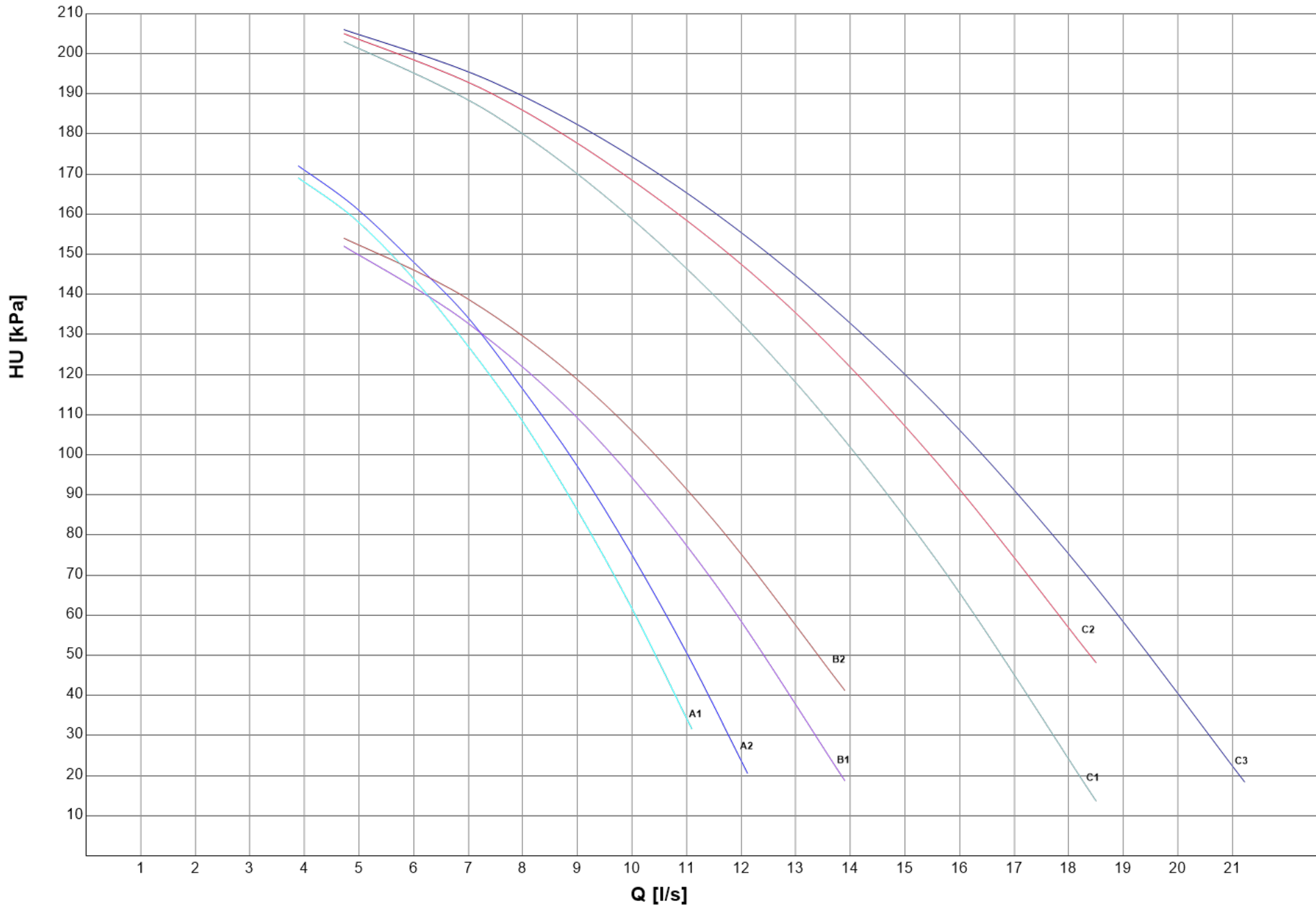

HYDRONIC GROUP

WARM WATER HEAT EX. USER SIDE - CD - 2 POMPE 2P AP (VAR SPEED)

SIZE	CH		HP		PUMP					CH	HP	
	Pfgross	Qfgross	Ptgross	Qcdgross	Rif.	Model	N.	F.L.A.	F.L.I.	HU	HU	
	[kW] (1)	[l/s] (1)	[kW] (1)	[l/s] (1)			Pole	[A]	[kW]	[kPa]	[kPa]	
0604		143,9		157,2	7,589	A1	LNTE 50-160/40/2	2	8	4,000		194
	LN	137,4		149,9	7,238							202
	SL	136,3		149,5	7,214							202
0704		159,6		174,3	8,413	A2	LNTE 50-160/40/2	2	8	4,000		184
	LN	150,8		165,5	7,988							193
	SL	153,3		167,3	8,075							192
0804		181,2		196,8	9,498	B1	LNTE 50-160/55/2	2	11	5,500		241
	LN	170,1		186,1	8,982							253
	SL	176,0		192,9	9,312							246
0904		202,6		220,1	10,63	B2	LNTE 50-160/55/2	2	11	5,500		227
	LN	191,1		211,9	10,23							236
	SL	192,7		212,8	10,27							235
1004		230,4		250,5	12,09	C1	LNTE 65-160/75/2	2	14	7,500		213
	LN	218,2		238,3	11,50							224
	SL	216,3		237,7	11,47							224
1104		266,0		288,0	13,90	C2	LNTE 65-160/75/2	2	14	7,500		198
	LN	250,3		272,8	13,17							211
	SL	250,3		276,8	13,36							208
1204		298,3		323,3	15,60	C3	LNTE 65-160/75/2	2	14	7,500		179
	LN	279,1		304,4	14,70							196
	SL	282,1		310,1	14,97							191

(1) Values refer to nominal conditions

CH Cooling mode

HP HP mode

Pf Cooling capacity unit (Cooling mode)

Pt Heating capacity unit (Heating mode)

Q Plant (side) exchanger water flow

F.L.I. Pump power input

F.L.A. Pump running current

HU Pump residual pressure head (Units with hydronic group without mains filter)

WARM WATER HEAT EX. USER SIDE - CD - 2 POMPE 2P AP (VAR SPEED)

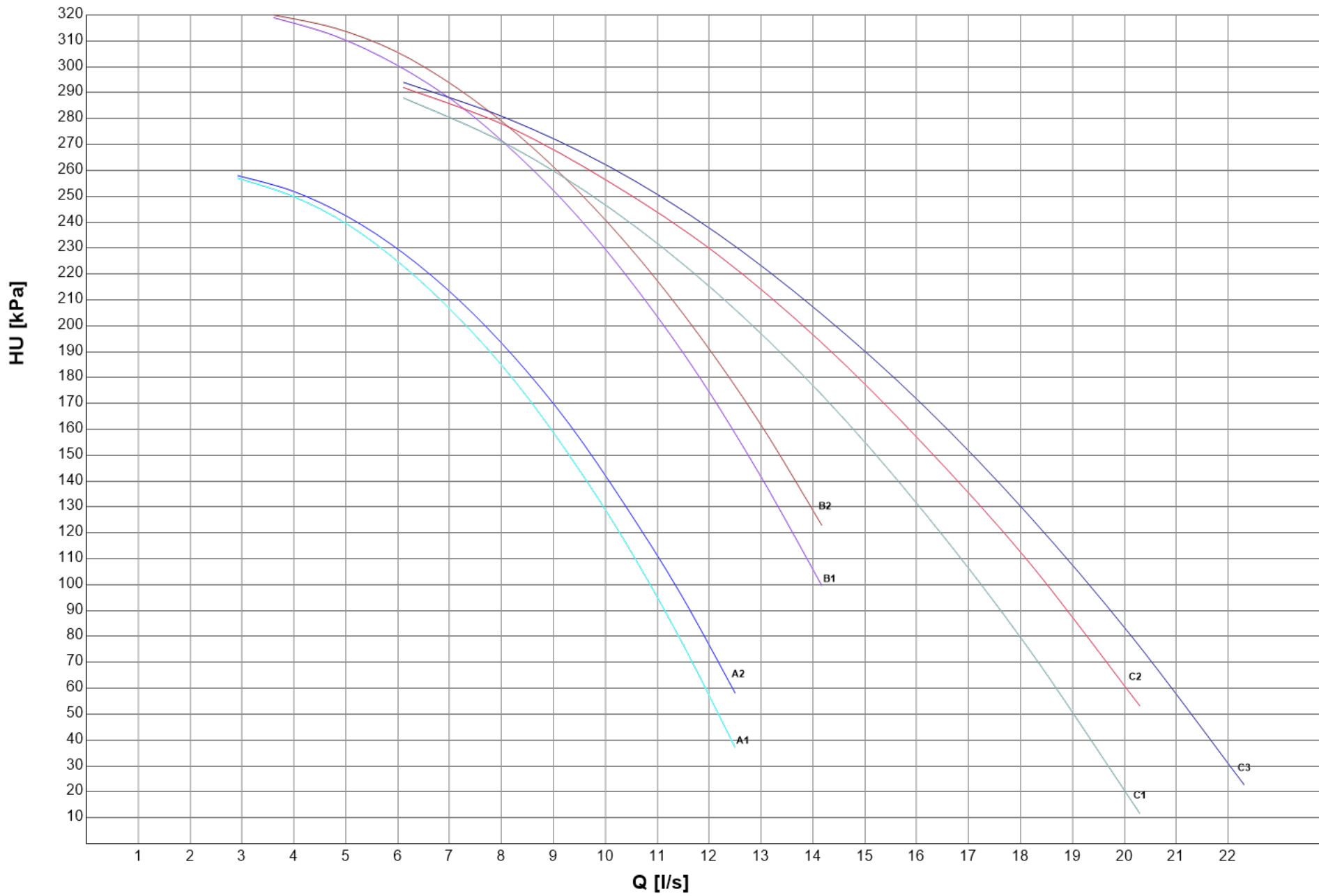

HYDRONIC GROUP

WARM WATER HEAT EX. USER SIDE - CD - 2 PUMPS 2P BP (VAR SPEED)

SIZE	CH		HP		PUMP					CH	HP	
	Pfgross	Qfgross	Ptgross	Qcdgross	Rif.	Model	N.	F.L.A.	F.L.I.	HU	HU	
	[kW] (1)	[l/s] (1)	[kW] (1)	[l/s] (1)			Pole	[A]	[kW]	[kPa]	[kPa]	
0604		143,9		157,2	7,589	A1	LNTE 50-125/22/2	2	5	2,200		85,8
	LN	137,4		149,9	7,238							94,4
	SL	136,3		149,5	7,214							95,0
0704		159,6		174,3	8,413	B1	LNTE 50-125/30/2	2	6	3,000		117
	LN	150,8		165,5	7,988							127
	SL	153,3		167,3	8,075							125
0804		181,2		196,8	9,498	B2	LNTE 50-125/30/2	2	6	3,000		101
	LN	170,1		186,1	8,982							114
	SL	176,0		192,9	9,312							105
0904		202,6		220,1	10,63	C1	LNTE 65-125/30/2	2	6	3,000		88,4
	LN	191,1		211,9	10,23							95,6
	SL	192,7		212,8	10,27							94,8
1004		230,4		250,5	12,09	D1	LNTE 65-125/40/2	2	8	4,000		109
	LN	218,2		238,3	11,50							119
	SL	216,3		237,7	11,47							120
1104		266,0		288,0	13,90	D2	LNTE 65-125/40/2	2	8	4,000		92,9
	LN	250,3		272,8	13,17							106
	SL	250,3		276,8	13,36							103
1204		298,3		323,3	15,60	E1	LNTE 65-125/55/2	2	11	5,500		129
	LN	279,1		304,4	14,70							145
	SL	282,1		310,1	14,97							141

(1) Values refer to nominal conditions

CH Cooling mode

HP HP mode

Pf Cooling capacity unit (Cooling mode)

Pt Heating capacity unit (Heating mode)

Q Plant (side) exchanger water flow

F.L.I. Pump power input

F.L.A. Pump running current

HU Pump residual pressure head (Units with hydronic group without mains filter)

WARM WATER HEAT EX. USER SIDE - CD - 2 PUMPS 2P BP (VAR SPEED)

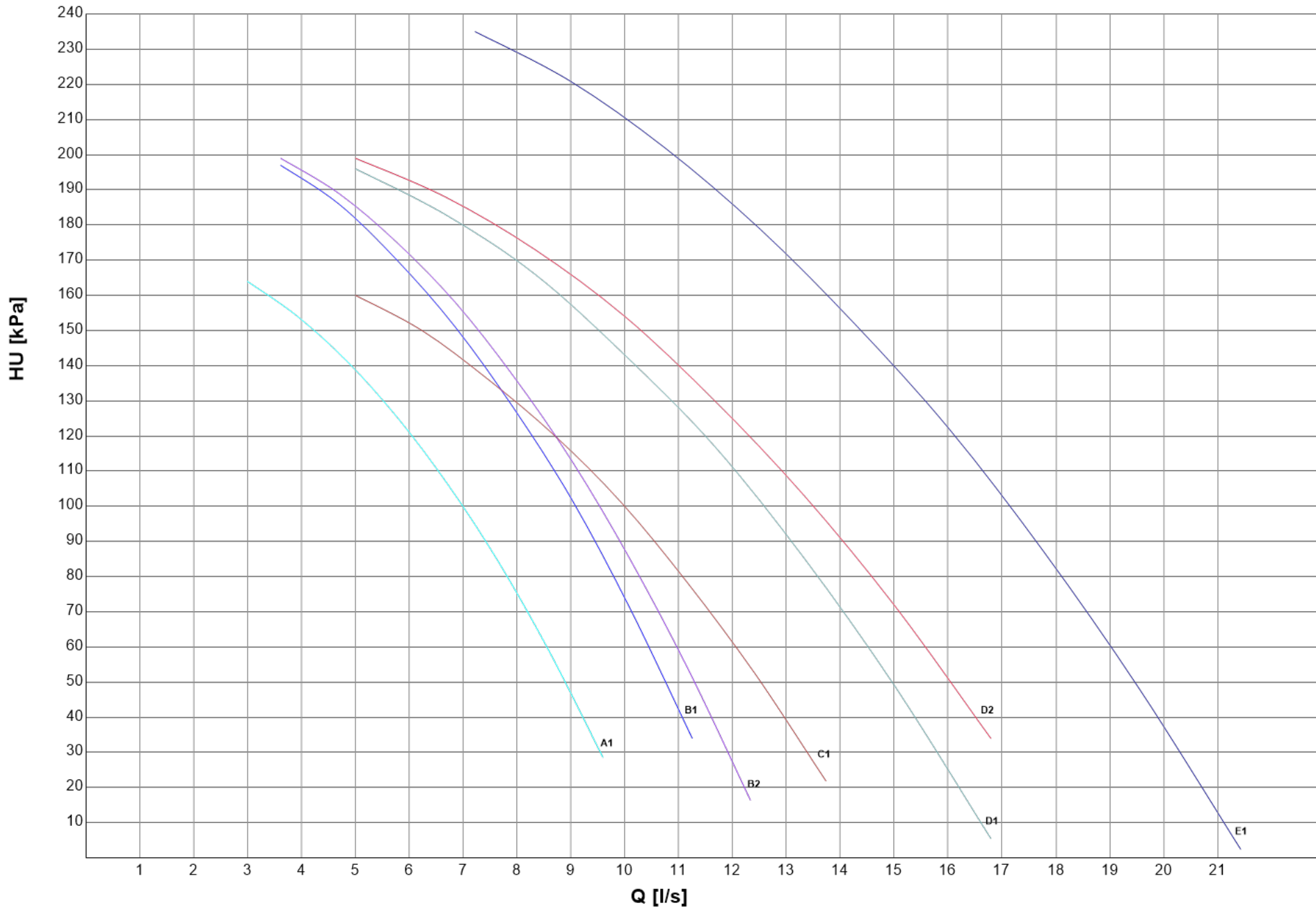

HYDRONIC GROUP

WARM WATER HEAT EX. USER SIDE - CD - 2 PUMPS 2P HH (FIX SPEED)

SIZE	CH		HP		PUMP					CH	HP	
	Pfgross	Qfgross	Ptgross	Qcdgross	Rif.	Model	N.	F.L.A.	F.L.I.	HU	HU	
	[kW] (1)	[l/s] (1)	[kW] (1)	[l/s] (1)			Pole	[A]	[kW]	[kPa]	[kPa]	
0604		143,9		157,2	7,589	A1	LNTE 50-160/40/2	2	8	4,000		194
	LN	137,4		149,9	7,238							202
	SL	136,3		149,5	7,214							202
0704		159,6		174,3	8,413	A2	LNTE 50-160/40/2	2	8	4,000		184
	LN	150,8		165,5	7,988							193
	SL	153,3		167,3	8,075							192
0804		181,2		196,8	9,498	B1	LNTE 50-160/55/2	2	11	5,500		241
	LN	170,1		186,1	8,982							253
	SL	176,0		192,9	9,312							246
0904		202,6		220,1	10,63	B2	LNTE 50-160/55/2	2	11	5,500		227
	LN	191,1		211,9	10,23							236
	SL	192,7		212,8	10,27							235
1004		230,4		250,5	12,09	C1	LNTE 65-160/75/2	2	14	7,500		213
	LN	218,2		238,3	11,50							224
	SL	216,3		237,7	11,47							224
1104		266,0		288,0	13,90	C2	LNTE 65-160/75/2	2	14	7,500		198
	LN	250,3		272,8	13,17							211
	SL	250,3		276,8	13,36							208
1204		298,3		323,3	15,60	C3	LNTE 65-160/75/2	2	14	7,500		179
	LN	279,1		304,4	14,70							196
	SL	282,1		310,1	14,97							191

(1) Values refer to nominal conditions

CH Cooling mode

HP HP mode

Pf Cooling capacity unit (Cooling mode)

Pt Heating capacity unit (Heating mode)

Q Plant (side) exchanger water flow

F.L.I. Pump power input

F.L.A. Pump running current

HU Pump residual pressure head (Units with hydronic group without mains filter)

WARM WATER HEAT EX. USER SIDE - CD - 2 PUMPS 2P HH (FIX SPEED)

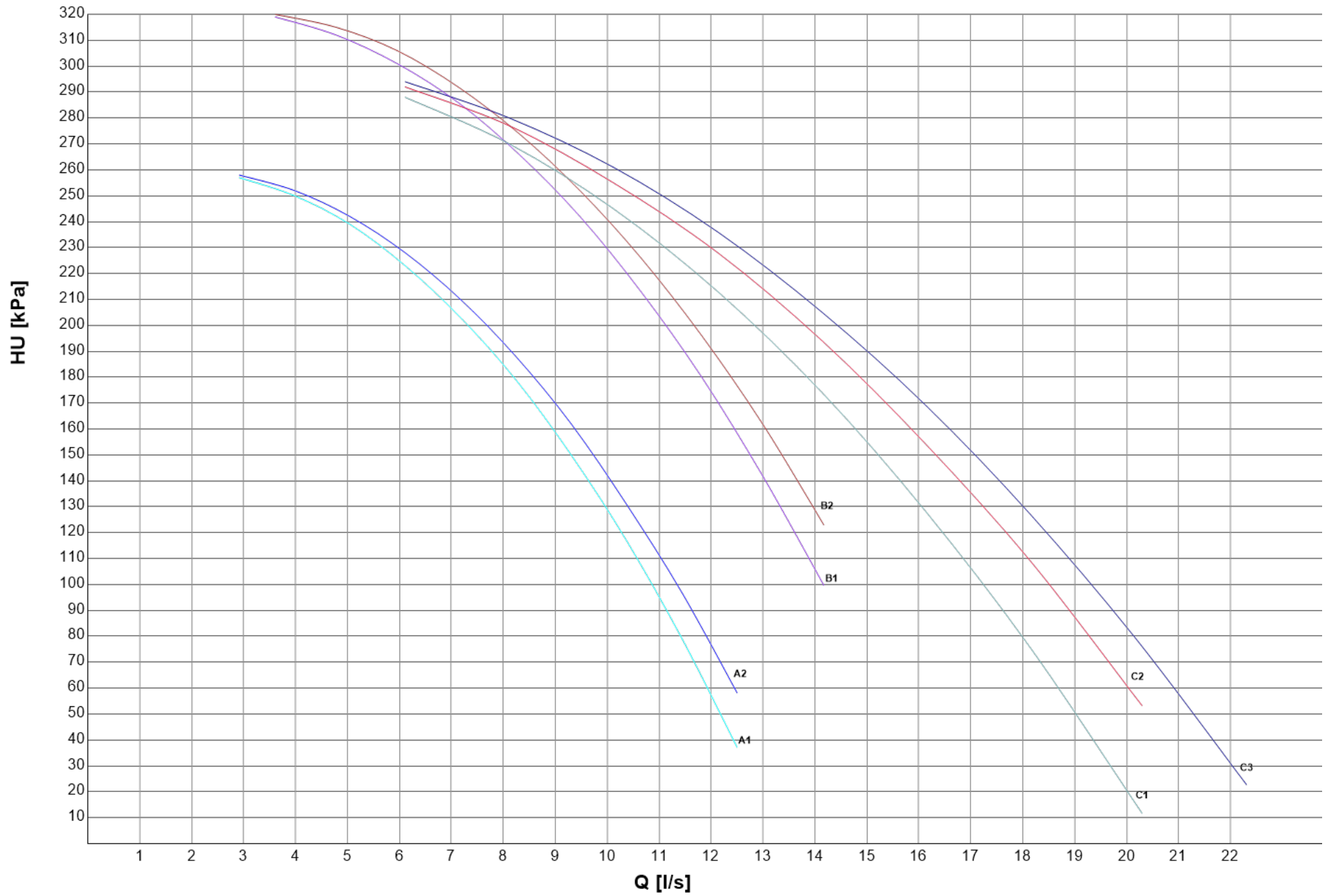

HYDRONIC GROUP

WARM WATER HEAT EX. USER SIDE - CD - 2 PUMPS 2P LH (FIX SPEED)

SIZE	CH		HP		PUMP					CH	HP	
	Pfgross	Qfgross	Ptgross	Qcdgross	Rif.	Model	N.	F.L.A.	F.L.I.	HU	HU	
	[kW] (1)	[l/s] (1)	[kW] (1)	[l/s] (1)			Pole	[A]	[kW]	[kPa]	[kPa]	
0604		143,9		157,2	7,589	A1	LNTE 50-125/22/2	2	5	2,200		85,8
	LN	137,4		149,9	7,238							94,4
	SL	136,3		149,5	7,214							95,0
0704		159,6		174,3	8,413	B1	LNTE 50-125/30/2	2	6	3,000		117
	LN	150,8		165,5	7,988							127
	SL	153,3		167,3	8,075							125
0804		181,2		196,8	9,498	B2	LNTE 50-125/30/2	2	6	3,000		101
	LN	170,1		186,1	8,982							114
	SL	176,0		192,9	9,312							105
0904		202,6		220,1	10,63	C1	LNTE 65-125/30/2	2	6	3,000		88,4
	LN	191,1		211,9	10,23							95,6
	SL	192,7		212,8	10,27							94,8
1004		230,4		250,5	12,09	D1	LNTE 65-125/40/2	2	8	4,000		109
	LN	218,2		238,3	11,50							119
	SL	216,3		237,7	11,47							120
1104		266,0		288,0	13,90	D2	LNTE 65-125/40/2	2	8	4,000		92,9
	LN	250,3		272,8	13,17							106
	SL	250,3		276,8	13,36							103
1204		298,3		323,3	15,60	E1	LNTE 65-125/55/2	2	11	5,500		129
	LN	279,1		304,4	14,70							145
	SL	282,1		310,1	14,97							141

(1) Values refer to nominal conditions
 CH Cooling mode
 HP HP mode
 Pf Cooling capacity unit (Cooling mode)
 Pt Heating capacity unit (Heating mode)

Q Plant (side) exchanger water flow
 F.L.I. Pump power input
 F.L.A. Pump running current
 HU Pump residual pressure head (Units with hydronic group without mains filter)

WARM WATER HEAT EX. USER SIDE - CD - 2 PUMPS 2P LH (FIX SPEED)

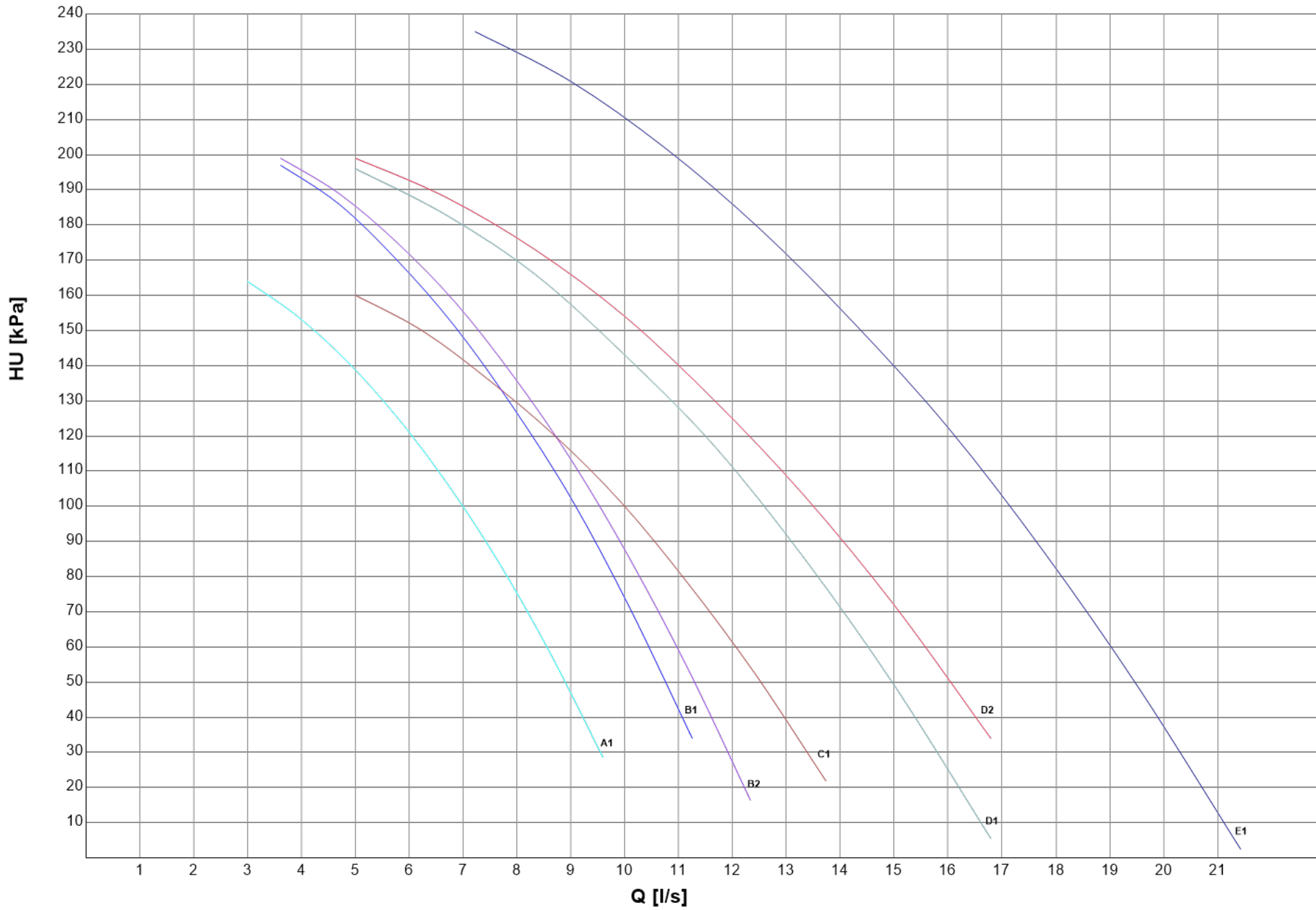

HYDRONIC GROUP

WARM WATER HEAT EX. USER SIDE - CD - 2 PUMPS 4P LH (FIX SPEED)

SIZE	CH		HP		PUMP					CH	HP	
	Pfgross	Qfgross	Ptgross	Qcdgross	Rif.	Model	N.	F.L.A.	F.L.I.	HU	HU	
	[kW] (1)	[l/s] (1)	[kW] (1)	[l/s] (1)			Pole	[A]	[kW]	[kPa]	[kPa]	
0604		143,9		157,2	7,589	A1						109
	LN	137,4		149,9	7,238							116
	SL	136,3		149,5	7,214							117
0704		159,6		174,3	8,413	A2	4	7	3,000			101
	LN	150,8		165,5	7,988							110
	SL	153,3		167,3	8,075							108
0804		181,2		196,8	9,498	A3						90,2
	LN	170,1		186,1	8,982							101
	SL	176,0		192,9	9,312							94,0
0904		202,6		220,1	10,63	B1	4	8	4,000			92,9
	LN	191,1		211,9	10,23							98,5
	SL	192,7		212,8	10,27							97,9
1004		230,4		250,5	12,09	C1						126
	LN	218,2		238,3	11,50							135
	SL	216,3		237,7	11,47							135
1104		266,0		288,0	13,90	C2	4	12	5,500			118
	LN	250,3		272,8	13,17							128
	SL	250,3		276,8	13,36							125
1204		298,3		323,3	15,60	C3						106
	LN	279,1		304,4	14,70							119
	SL	282,1		310,1	14,97							115

(1) Values refer to nominal conditions

CH Cooling mode

HP HP mode

Pf Cooling capacity unit (Cooling mode)

Pt Heating capacity unit (Heating mode)

Q Plant (side) exchanger water flow

F.L.I. Pump power input

F.L.A. Pump running current

HU Pump residual pressure head (Units with hydronic group without mains filter)

WARM WATER HEAT EX. USER SIDE - CD - 2 PUMPS 4P LH (FIX SPEED)

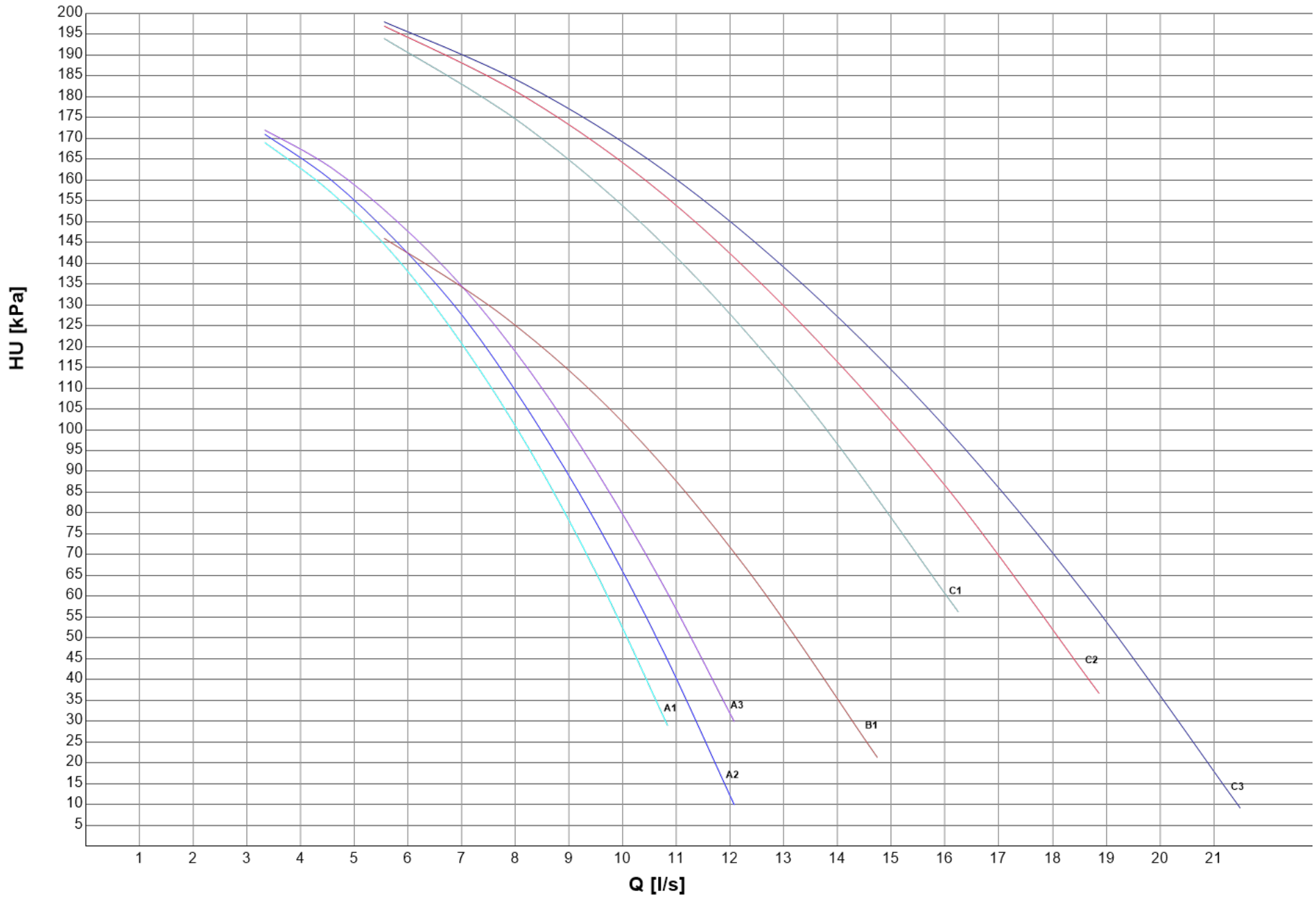



for a greener tomorrow

Eco Changes is the Mitsubishi Electric Group's environmental statement, and expresses the Group's stance on environmental management. Through a wide range of businesses, we are helping contribute to the realization of a sustainable society.



MITSUBISHI ELECTRIC HYDRONICS & IT COOLING SYSTEMS S.p.A.

Head Office: Via Caduti di Cefalonia 1 - 36061 Bassano del Grappa (VI) - Italy

Tel (+39) 0424 509 500 - Fax (+39) 0424 509 509

www.melcohit.com

