

Data Book

Data Book

DB_ME_MECH-iF-G05 0411 - 0902_012024_EN_rev01 R513A

ELCA_Engine ver.4.8.2.0

❄️ COOLING

MECH-iF-G05 0411 - 0902

407-921 kW

Chiller, air source for outdoor installation

R R513A

SCREW

INV. DRIVEN COMP.

T SHELL & TUBES

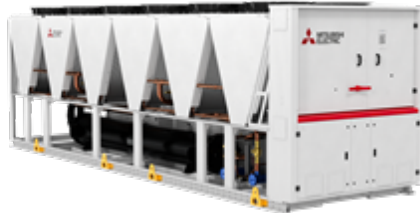

(The photo of the unit is indicative and may vary depending on the model)

- ✓ LOW GWP REFRIGERANT
- ✓ HIGH EFFICIENCY
- ✓ REDUCED FOOTPRINT
- ✓ WIDE OPERATING RANGE

- ✓ SMART CONTROL FUNCTIONS
- ✓ UNIT AND PLANT HARMONY
- ✓ INTEGRATED HYDRONIC GROUP
- ✓ VARIABLE PRIMARY FLOW

1	CERTIFICATIONS	pg.5
1.1	Product certifications	pg.5
1.2	Voluntary product certifications	pg.5
1.3	System certifications	pg.5
2	PRODUCT PRESENTATION	pg.6
2.1	Green certification relevant	pg.6
2.2	Unit description	pg.7
2.3	Key features	pg.7
2.4	Operating principles	pg.8
3	INCIPIIT	pg.11
4	UNIT DESCRIPTION	pg.12
4.1	Standard unit composition	pg.12
4.2	Unit standard composition – additional information	pg.18
4.3	Versions	pg.18
4.4	Configurations	pg.18
4.5	Electronic controller	pg.19
5	OPTIONS	pg.20
5.1	Options	pg.20
5.2	Options - additional information	pg.32
6	GENERAL TECHNICAL DATA	pg.42
7	TECHNICAL DATA SEASONAL EFFICIENCY IN COOLING (EN14825 VALUE)	pg.45
8	OPERATING LIMITS	pg.46
8.1	Operating limits - graphs	pg.46
9	HYDRAULIC DATA	pg.48
10	ELECTRIC DATA	pg.49
10.1	Electrical data	pg.49
10.2	Dimensions of the electrical connections to the main switch	pg.52
11	FULL LOAD SOUND LEVEL	pg.53

12	DIMENSIONAL DRAWINGS	pg.56
12.1	Dimensional drawings	pg.56
12.2	Legend of pipe connections	pg.62
13	HYDRONIC KIT	pg.64
13.1	Hydronic groups	pg.64
14	ATTACHMENTS	pg.78
14.1	Variable flow control	pg.78
14.2	Compressor rephasing and electromagnetic compatibility	pg.91

Liability disclaimer

The present publication is drawn up by of information only and does not constitute an offer binding upon Mitsubishi Electric Hydronics & IT Cooling Systems S.p.A.

Mitsubishi Electric Hydronics & IT Cooling Systems S.p.A. has compiled the content of this publication to the best of its knowledge. The data contained herein are subject to change without notice. Mitsubishi Electric Hydronics & IT Cooling Systems S.p.A. explicitly rejects any liability for any direct or indirect damage, in the broadest sense, arising from or related to the use and/or interpretation of this publication. All content is copyrighted by Mitsubishi Electric Hydronics & IT Cooling Systems S.p.A.

The units highlighted in this publication contain R513A [GWP₁₀₀ 572] fluorinated greenhouse gases.

LEGEND

Data Book
DB_ME_MECH-iF-G05 0411 - 0902_012024_EN
R513A

Functions

 **COOLING** Cooling

Refrigerant

 **R513A** R513A

Compressors

 **SCREW** Screw compressor

 **INV.DRIVEN COMP.** VSD Screw compressors

Fan

 **EC AXIAL** EC axial fan

Exchangers

 **SHELL & TUBES** Shell & Tubes

Other features

 Eurovent

 VPF
 VARIABLE PRIMARY FLOW

1.1 Product certifications



1.2 Voluntary product certifications



Check ongoing validity of certificate:
www.eurovent-certification.com
or
www.certiflash.com

1.3 System certifications



Quality System complying with the requirements of UNI EN ISO 9001 regulation



Occupational Health and Safety Management System complying with the requirements of UNI ISO 45001



Environmental Management System complying with the requirements of UNI EN ISO 14001 regulation

2.1 Green certification relevant

FOCUS ON GREEN CERTIFICATION RELEVANT

Mitsubishi Electric Hydronics & IT Cooling Systems S.p.A., as a major player in the world HVAC market and a leading manufacturer of energy efficient, sustainable HVAC solutions, recognizes and supports the diffusion of green certification systems, as an effective way to deliver high performance buildings and improve the quality and the sustainability of the built environment.

Since the first certification system was introduced at the beginning of the 1990s, the demand for certified buildings has grown considerably, as well as the number of standards, rating and certification programs. Operating worldwide Mitsubishi Electric Hydronics & IT Cooling Systems S.p.A., has extensive experience with many of them and is active member of Green Building Council Italy.

Mitsubishi Electric Hydronics & IT Cooling Systems S.p.A., commitment to develop responsible and sustainable HVAC solutions, is reflected by a full range of premium efficiency products and systems, designed with special care to improve building energy performance ratings, according to major certification protocols, including LEED, BREAM, GREENSTAR, BCA, NABERS, DNGB, HQE and BEAM.

To find out more about how our products contribute to enhanced green certification rating and energy performance of a building, please refer to:
https://www.melcohit.com/EN/Environment/green_certifications/



2.2 Unit Description

Outdoor unit for the production of chilled water with variable-speed single screw compressors optimized for R513A, EC fans, micro-channel full-aluminum condensing coils, single-pass shell and tubes evaporator, electronic expansion valve and economizer.

Base and supporting structure and panels are made of galvanized epoxy powder coated steel with increased thickness. The screw compressors feature the variable speed technology thanks to the external air cooled inverter, for maximum efficiency. Moreover, they feature the Variable Vi (compression ratio) technology, to change the internal geometry according to the operating conditions.

Thanks to the accurate sizing of all internal components and the use of variable speed technology, the unit ensures flexibility, reliability, and maximum efficiency in every operating condition.

2.3 Key Features

LOW GWP REFRIGERANT

New generation refrigerant R513A, with reduced greenhouse effect in comparison with traditional HFC refrigerants (Global Warming Potential GWP of R513A = 572, GWP of R134a = 1300 as per IPCC rev. 5) and zero impact on the ozone layer. Non-flammable (ASHRAE 34, ISO 817: class A1).

HIGH EFFICIENCY

Very high efficiency at full and partial loads, at the highest market levels, thanks to the adopted technological solutions. These units ensure low operating costs and therefore a quick payback time.

REDUCED FOOTPRINT

These new units have a reduced footprint, making them the best solution both for new plants (thanks to high efficiency) and for the replacement of obsolete units in existing plants, offering a very high efficiency increase with the same dimensions and cooling capacity.

WIDE OPERATING RANGE

Full load operation is guaranteed up to 48 °C outdoor air temperature during the summer season, and up to -20 °C outdoor air temperature during the winter season with dedicated accessories. The unit is capable of producing chilled water with evaporator output temperatures from -10 °C to 18 °C.

SMART CONTROL FUNCTIONS

Wide choice of smart functions available: night mode, limitation of current consumption, control of refrigerant leaks without devices.

UNIT AND PLANT HARMONY

Low inrush current and a higher power factor than similar fixed speed units, provide an easy electrical installation which is not stressed during start-up nor are extra devices for power factor correction needed. The use of VSD technology allows the unit to partialize in a stepless way, with consequent lower leaving water temperature fluctuations.

INTEGRATED HYDRONIC GROUP

The integrated hydronic unit contains the main hydraulic components; it is available in different configurations that include two orthogonal 2-pole pumps, high or low head, fixed or variable speed.

VARIABLE PRIMARY FLOW

Energy savings due to variable pump speed management based on load demand and the variable flow ensures the units also function in critical working conditions.

2.4 Operating principles

CONFIGURATIONS

- , **standard unit**

No heat recovery is possible.

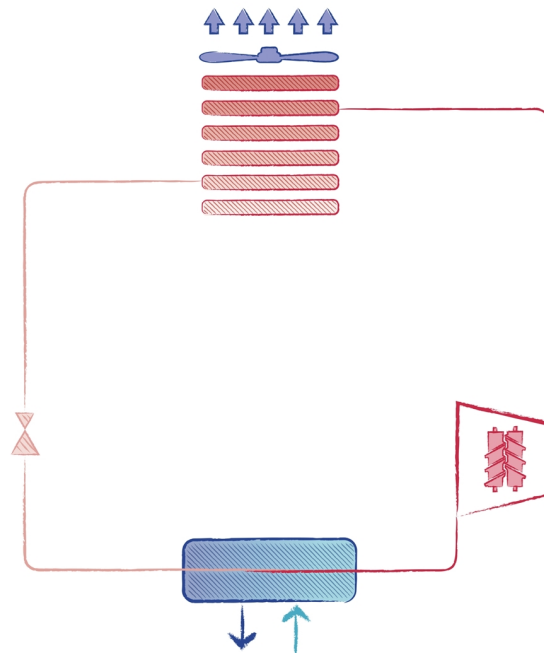

-D, unit with partial heat recovery

Each refrigerant circuit is fitted with a desuperheater.

The superheating heat recovery is only possible when the temperature of the hot water circuit is lower than the compressor discharge temperature. The heat recovery and its amount depends on the unit's operating conditions, in particular the outdoor air temperature and the load percentage. It is advised to interrupt the water flow to the desuperheater when the conditions for an actual heat recovery are not met.

The smart management of the desuperheater pump(s) is possible with the option 3371 D – RELAY 1 PUMP (ON/OFF), further information is available in the bulletin section dedicated to accessories.

Heat recovery: ON

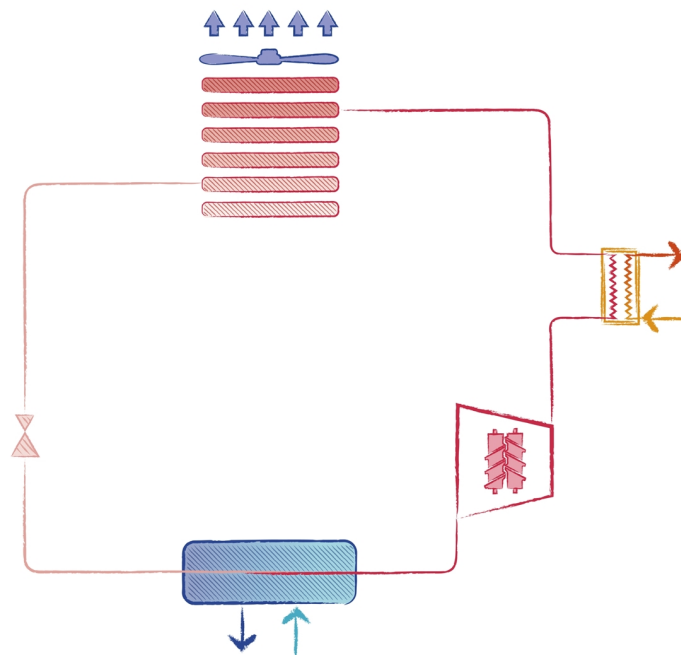

Heat recovery: OFF (water flow stopped)

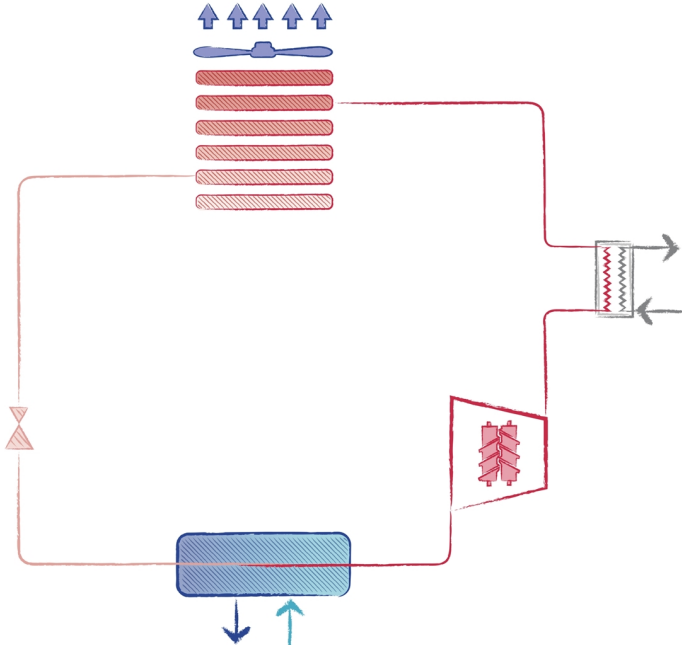

MECH-iF-G05-D-SL 0902

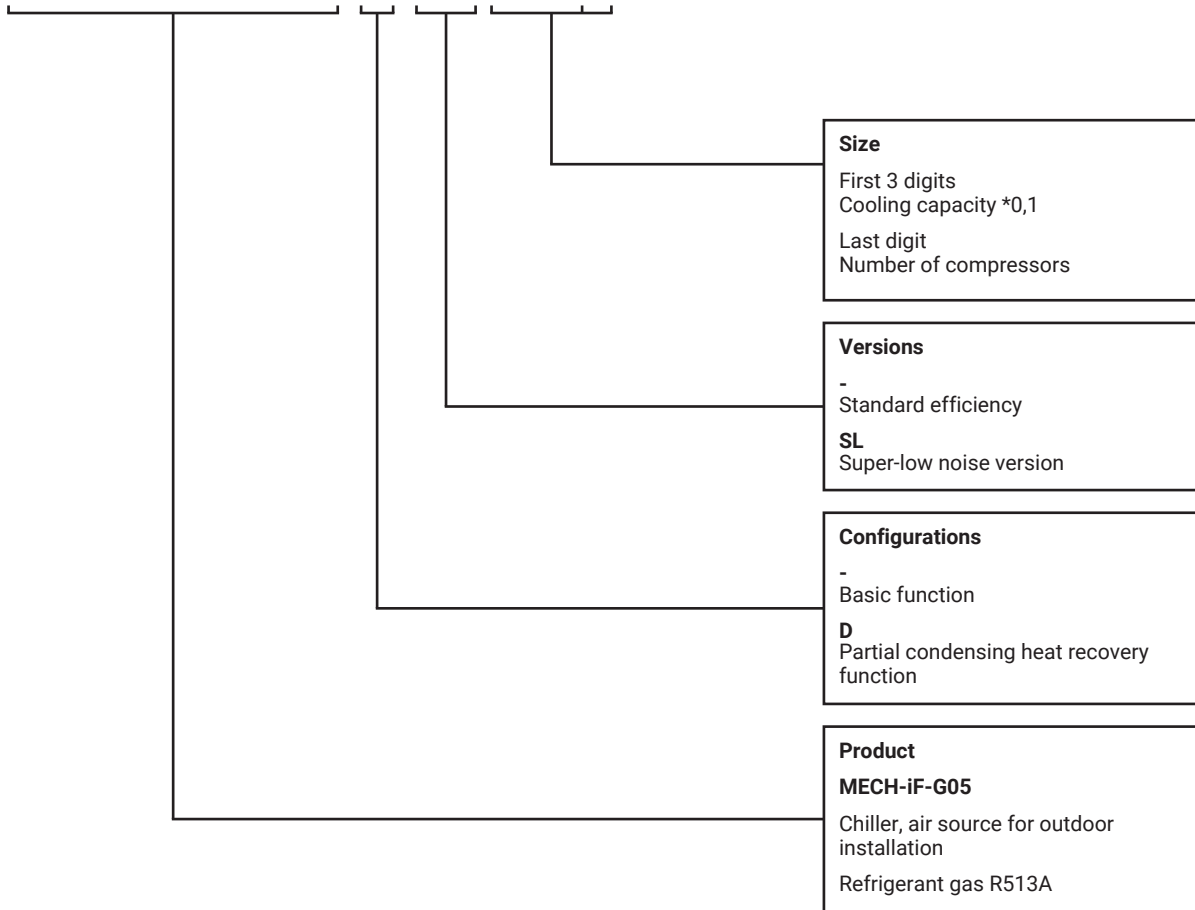

4.1 Standard unit composition

Chiller, air source for outdoor installation

Outdoor unit for the production of chilled water with variable-speed single screw compressors optimized for R513A, EC fans, micro-channel full-aluminum condensing coils, single-pass shell and tubes evaporator, electronic expansion valve and economizer.

Base and supporting structure and panels are made of galvanized epoxy powder coated steel with increased thickness. The screw compressors feature the variable speed technology thanks to the external air cooled inverter, for maximum efficiency. Moreover, they feature the Variable Vi (compression ratio) technology, to change the internal geometry according to the operating conditions.

Thanks to the accurate sizing of all internal components and the use of variable speed technology, the unit ensures flexibility, reliability, and maximum efficiency in every operating condition.

Installation note

The unit is supplied fully refrigerant charged and factory tested. On site installation only requires power and hydraulic connection.

Structure

Structure specifically designed for outdoor installation. Base and frame in hot-galvanised steel sheet of suitable thickness. All parts polyester-powder painted to assure total weather resistance. Painting: RAL 7035 textured finish.

Refrigerant circuit

Unit designed with separate and independent refrigerant circuits in order to ensure continuous operation and easy maintenance. In addition to the main components described in the following sections, each refrigerant circuit is fitted as standard with:

- check valve on the compressor delivery line
- compressor's discharge valve
- liquid line shut-off valve
- single-pass dry shell & tube evaporator
- differential pressure switch on evaporator
- antifreeze electric heater for heat exchangers
- condensing and RED cooler coils in AL/AL microchannel.
- drier filter with replaceable cartridge
- refrigerant line sight glass with humidity indicator
- electronic expansion valve
- liquid line shut-off device (function performed by electronic expansion valve with ultracap)
- liquid injection in the compressor
- HP/LP dual relief valve with switch
- High pressure switches
- high and low pressure transducers
- compressor oil level check
- crankcase heater on each compressor
- economizer circuit with brazed plate heat exchanger (one for each compressor)
- electronic expansion valve on the economizer circuit
- valve on economizer port on the compressor
- internal leak detector

UNIT DESCRIPTION

Data Book
DB_ME_MECH-iF-G05 0411 - 0902_012024_EN
R513A

Inverter-screw compressors

Single screw compressors, MS model, designed by Mitsubishi Electric.

Compact compressors with integrated oil separator and air-cooled external frequency modulation inverter.

Semi-hermetic single screw compressors with single central screw rotor and two twin star satellite rotors positioned one on one side and one on the other. The motor drives the screw with a variable speed range of 1:4 thanks to the coupling with the dedicated inverter.

The inverter cooling is guaranteed by the built-in forced ventilation that allows to dispose of the heat generated.

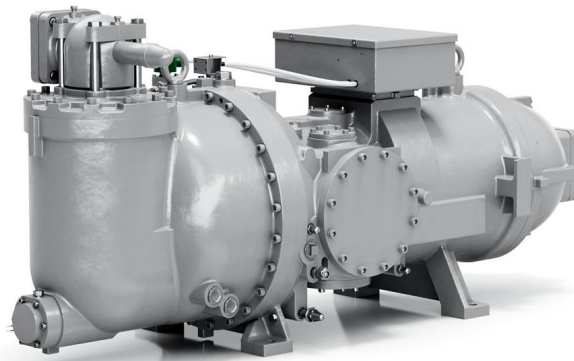

The minimum percentage of cooling capacity of the unit (referred to the conditions of water produced at 7 ° C, air 35 ° C) is:

- 25% for single compressor unit
- 13% for 2-compressor units

Plant side heat exchanger

Dry expansion type shell and tube heat exchanger; it acts as an evaporator with refrigerant flow inside the pipes and water flow on the shell side. The heat exchanger is a single-pass type to provide almost perfect countercurrent heat exchange. The water flow on the shell side is fitted with baffles to increase turbulence and therefore the efficiency of exchange. The steel shell has insulation lining made of flexible closed cells elastomeric foam (thermal conductivity 0.033W/mK at 0°C) coupled with 3 mm layer of crosslinked PE foam with a surface film of embossed PE for a total thickness of 9 mm. The tube nest is manufactured using copper tubes with internal grooves to improve heat exchange and each pipe is mechanically expanded onto the tube plates. The heat exchanger is fitted with a differential pressure switch which controls the flow of water when the unit is working, in this way preventing the formation of ice inside; when pumps stop, the antifreeze control is up to an electrical resistance. The heat exchanger is compliant with PED standard work pressure requisites. Upon request, the heat exchanger can be supplied with AS1210 certificate.

User-side heat exchanger connections H type accessible with grooved coupling with weld end counter-pipe user side (supplied separately). The connections are on the left side of the machine looking at the electrical panel of the unit.

UNIT DESCRIPTION

Data Book
DB_ME_MECH-iF-G05 0411 - 0902_012024_EN
R513A

Source side heat exchanger

Microchannel coils ideally positioned on a “V” block structure to optimize airflow and heat transfer. Made entirely in aluminum, the coils are not subjected to galvanic corrosion.

Fins and manifolds are made of aluminum AA3003 while the channels are made of a new aluminum alloy so defined Long Life Alloy (LLA). LLA alloy has a very fine grain microstructure that guarantees higher mechanical properties and a higher resistance to the inter-granular corrosion.

Channel small section favor refrigerant fluid turbulence, which enhances the heat exchange. Tube geometry maximize the surface touched by the air, thus allowing compact dimension and refrigerant charge reduction.

The unit comes with internally developed RED Cooler technology, a patented technology solution that improves unit efficiency and reduces exergy loss in the expansion phase. The refrigerant is subcooled in dedicated coils, where it is cooled down to a temperature very close to the outside air, making the most of the subcooling energy.



UNIT DESCRIPTION

Data Book
DB_ME_MECH-iF-G05 0411 - 0902_012024_EN
R513A

Fan section source side

Axial electronically commutated fans (EC fans), with external rotor, profiled die-cast aluminium blades, housed in aerodynamic hoods complete with guard grille. 6-poles electric motor with built-in thermal protection. The brushless motor, governed by a special controller, continuously adjust fans' speed to minimize energy consumption, electromagnetic noises and current's absorption even during start-up phase. The speed control is done by signal 0-10V output from the controller with the possibility of splitting half of the fans attached to each circuit when the condensation temperature drops.

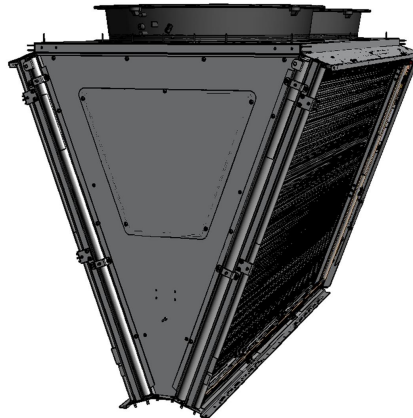

Fans rotational speed:

- 950 rpm for the basic version
- 850 rpm for the basic version + kit NR
- 800 rpm for the super silent version (-SL)

Super Low noise version features

The Super Low noise units (version SL) feature:

Reduced fan speed (the speed is automatically increased in case of particularly tough environmental conditions).

Special soundproofing insulation of the compressors enclosure (multilayer lining of polyurethane foam and double sound-insulating gaiter, total thickness 52 mm)

Soundproofing lining of suction and delivery pipes of the compressors with 9mm anti-condensation mat, 1mm insulating viscous coating and 8mm cross-linked polyethylene foam coating.

Covering of the exposed pipes between the V-blocks with painted metal sheets with a special soundproofing insulation (multilayer lining of polyurethane foam and sound-insulating gaiter, total thickness 30 mm)

If the hydronic is present, the pump enclosure is acoustically insulated by a 30 mm thick lining of polyester fibres (Fiberform)

UNIT DESCRIPTION

Data Book
DB_ME_MECH-iF-G05 0411 - 0902_012024_EN
R513A

Electrical and control panel

Electrical and control panel built in accordance with EN60204-1 standard, complete with:

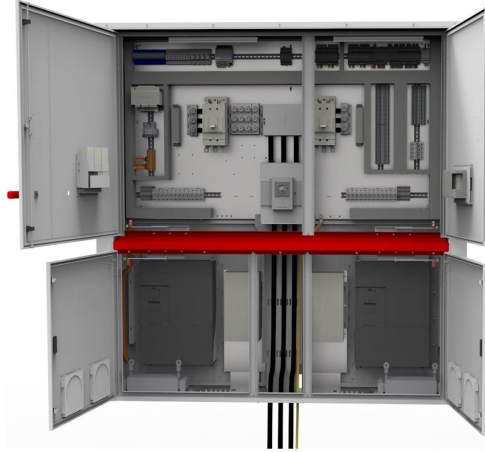

- power supply 400V/3ph/50Hz
- starting compressors with frequency converter inside the electrical panel
- cooling of the frequency converter with forced ventilation system
- Mitsubishi proprietary circuit breaker on each compressor power circuit
- EMI filter on the power circuit of each compressor
- DC reactor of Mitsubishi proprietary technology on the power circuit of each compressor
- general door lock isolator
- power circuit with electric bus bar distribution system
- control circuit transformer
- numbered cables
- kit on the power circuits of the compressors for conducted emissions on the power line compliant with EN61000-6-4 for industrial environments
- unit ON / OFF
- enabling unit LOC. -0- REM. via parameter
- terminals for cumulative alarm block
- compressors protection with internal thermal overload
- spring-type control circuit terminal board
- integrated discharge temperature probe on compressor
- ambient air probe for oil sump heater management and fractionation of the number of the working fans
- Electronic control W3000+
- KIPLink
- fluid temperature control on the discharge probe
- forced ventilation of the electrical board
- bottom cable entry
- Modbus interface for communication between controller and inverter compressors
- lights on electrical board + power socket
- phase sequence relay + over/under voltage control
- voltage presence relay
- Pump control relay + 0-10V modulating signal to control an external variable speed pump with the VPF.E control logic (plant-side constant ΔT for plants with primary circuit only and terminals with bypass)

UNIT DESCRIPTION**Data Book**
DB_ME_MECH-iF-G05 0411 - 0902_012024_EN
R513A**Certification and applicable directives**

The unit complies with the following directives and relative amendments:

- Machine directive 2006/42/EC
- PED Directive 2014/68/EC
- 2014/30/EC EMC Directive
- 2014/53/EU Radio Equipment Directive
- 2011/65/EU Restriction of the use of certain hazardous substances in electrical and electronic equipment (RoHS 2)
- F-Gas Regulation 517/2014/EC
- WEEE (Waste Electrical and Electronic Equipment) Directive
- 1907/2006 REACH
- ErP Directive 2009/125/EC
- EUROVENT Certification program
- CE - Declaration of conformity certificate for the European Union
- ISO 9001 - Company Quality Management System certification
- ISO 14001 - Company Environmental Management System certification

Tests

Tests performed throughout the production process, as indicated in ISO9001.

Performance or noise tests can be performed by highly qualified staff in the presence of customers.

Performance tests comprise the measurement of:

- electrical data
- water flow rates
- working temperatures
- power input
- power output
- pressure drops on the water-side exchanger both at full load (at the conditions of selection and at the most critical conditions for the condenser) and at part load conditions.

During performance testing it is also possible to simulate the main alarm states.

Noise tests are performed to check noise emissions according to ISO9614.

4.2 Unit standard composition – Additional information

Noise reduction in part load conditions

Units are able to modulate in a stepless way the capacity, thanks to the variable speed drive compressors and variable speed fans. This means that when working at partial loads, the units will produce less noise compared to the nominal condition capacity.

In the following table there are the reductions in terms of dB(A) in part load conditions versus the nominal condition (point A) of the several versions. The part load conditions taken into consideration (point B, C, D) for the comparison are the conditions defined by EN14825 standard for the SEER parameter calculation (air source units, fan coil application, variable outlet).

SEER points	LOAD	STD version	-NR / -SL versions
A	100%	-	-
B	74%	-5 dB(A)	-4 dB(A)
C	47%	-10 dB(A)	-9 dB(A)
D	21%	-14 dB(A)	-13 dB(A)

4.3 Versions

- Standard Version

Single version of unit with high efficiency, excellent heating capacity/footprint ratio and standard compressor acoustical enclosure.

-SL - Super Low noise

This configuration provides specific sound insulation for the whole refrigerant circuit and pumps (if any), and a reduction of the fan speed.

The fan speed is automatically increased in case of particularly tough environmental conditions.

4.4 Configurations

- , standard unit

Standard unit for production of chilled water

UNIT DESCRIPTION

Data Book
DB_ME_MECH-iF-G05 0411 - 0902_012024_EN
R513A

-D, unit with partial heat recovery

Unit for the production of chilled water, equipped with an auxiliary heat exchanger (desuperheater) on the compressor discharge for superheat recovery. The recovered heat is approximately the 20% of the total cooling capacity and can be used for domestic hot water production or other secondary uses, such as the integration of an existing boiler.

4.5 Electronic controller

Electronic control W3000+

W3000+ control is available with the new KIPLink (Keyboard In your Pocket) user interface. Based on WiFi technology, it allows one to operate on the unit directly from the smartphone or tablet. Using KIPLink, it is possible to turn the unit on and off, adjust the set-point, plot the main operating variables, monitor in detail the status of the refrigerant circuits, the compressors, the fans and the pumps (if present) and display and reset the possible alarms. The regulation features the continuous modulation of capacity, based on sequential adjustment + DIP referring to the leaving water temperature. Diagnostics include complete alarm management, with "blackbox" functions (via PC) and alarm log (display or PC) for best analysis of unit behaviour. The built-in clock can be used to create an operating profile containing up to 4 typical days and 10 time bands, essential for efficient programming of energy production. Optional proprietary devices can perform the adjustment of the resources in systems made of several units. Consumption metering and performance measurement are possible as well. The variable primary flow control is always available as per standard (VPF.E function). Supervision is available with different options, using proprietary devices or by integration into third party systems using ModBus, BACnet, BACnet-over-IP, Konnex, SNMP protocols. A dedicated wall-mounted keypad can be used for remote control of all the functions. Variable hydraulic flow control is standard (VPF.E function).



OPTIONS	DESCRIPTIONS	BENEFITS	AVAILABLE FOR MODELS
1020 REGULATIONS			
1019 HEAT EXCHANGERS AS1210 CERTIFIED	Heat exchangers AS1210 compliant (Australia Standard)		ALL
1560 POWER SUPPLY CONFIGURATION			
1561 DOUBLE POWER SUPPLY (ATS)	An ATS (Automatic Transfer Switch) is installed within the electrical board. The device automatically switches the electrical load between a principal power supply (i.e. mains) and an auxiliary power supply (i.e. backup generator). The ATS automatically senses if one of the sources has lost or gained power. When an outage occurs in the principal power supply, the switch autonomously switches over to the secondary line. When the main line becomes available again the supply is restored to this line. It is possible to set the line priority and frequency of checking.	It enhances system's redundancy and reliability. Reduces unit's downtime in case of mains power outage.	ALL
5820 THERMAL ENERGY METER			
5821 THERMAL ENERGY METER	Device for measuring the capacity delivered by the unit. The accessory consists of: - 2 temperature probes, supplied loose, to be installed on the supply and return water pipes respectively - 1 heat meter, installed on board the machine (inside the electrical panel if space is sufficient), for the calculation of the capacity produced by the unit. the value is made visible both to counter unit and, if present, to BMS.	It allows to calculate the cooling power produced by the unit. The data can be viewed in the controller on board the unit or at BMS (if present).	ALL
4500 FAST RESTART			
4501 FAST RESTART (UPS EXCLUDED)	Unit fast restart management after power failure	The management of the fast restart allows to minimize downtimes in case of power failure, keeping all the necessary unit safeties. This option requires an external 230V AC 300VA UPS power supply, by customer.	ALL
4502 FAST RESTART (UPS INCLUDED)	Unit fast restart management after power failure	The management of the fast restart allows to minimize downtimes in case of power failure, keeping all the necessary unit safeties. This option includes an electric device capable of keeping the controller power supply uninterrupted during a power failure. For duration of the UPS longer than 30 minutes, please contact our sales department.	ALL
380 NUMBERED WIRING			
383 NUMBERED WIRINGS+UK REQUESTS	Electrical board wires are identified by numbered labels. The reference numbers are indicated in the unit's wiring scheme.	Facilitate maintenance interventions to the electrical board connections.	ALL

OPTIONS

Data Book
DB_ME_MECH-IF-G05 0411 - 0902_012024_EN
R513A

OPTIONS	DESCRIPTIONS	BENEFITS	AVAILABLE FOR MODELS
3410 AUTOMATIC CIRCUIT BREAKERS			
3412 AUTOM. CIRCUIT BREAK. ON LOADS	Over-current switch on the major electrical loads.	In case of overcurrent allows resetting of the switch without the replacement of relative fuses.	ALL
1500 FREE-CONTACT FOR GENERAL ALARM			
1502 2-LEVEL ALARM MANAGEMENT	This option allows the management of a second level alarm. The accessory provides for an expansion of the controller.	It allows the management of a second alarm level. The types of alarm that can be parameterized are those with manual reset or only those locking for the unit. By standard both alarms are parameterized with contact NO (Normally Open) but can be set in NC (Normally Close) configuration.	ALL
3600 COMPRESSOR RUN STATUS SIGNAL			
3601 COMPRESSOR OPERATION SIGNAL	Auxiliary contacts providing a voltage-free signal.	Allows remote signalling of compressor's activation or remote control of any auxiliary loads.	ALL
6160 AUXILIARY INPUT			
6161 AUXILIARY SIGNAL 4-20mA	4-20 mA analog input	Allows to change the operating set-point according to the value of current applied to the analogue input.	ALL
6162 REMOTE SIGNAL DOUBLE SP	Allows to activate the Energy Saving set-point.	Allows to change the operating set-point according to a remote switch	ALL
6170 DEMAND LIMIT			
6171 INPUT REMOTE DEMAND LIMIT	Digital input (voltage free)	It permits to limit the unit's power absorption for safety reasons or in temporary situation.	ALL
6172 SIGNAL EXTERNAL CAPACITY CAP	Limits the unit cooling capacity to a specific % value, by acting on active resources and their operating frequencies. The unit can exceed this limit in specific conditions (e.g. start-up phase, oil recovery procedures).		ALL
6173 SMART CURRENT LIMIT	It keeps the absorbed current (and power) of the unit below a predetermined value, by acting on active resources and their operating frequencies. The unit can exceed this limit in specific conditions (oil recovery procedures).		ALL
1440 USER INTERFACE			
1442 KIPLink +7 INCH TOUCH SCREEN	In addition to KIPLink, the innovative user interface based on WiFi technology, the unit is equipped with the Touch interface, with a 7" WVGA colour display and a front USB port (WARNING: with outdoor temperature below 0°C the display response time may visibly increase).		ALL
1444 KIPLink + LARGE KEYBOARD	The unit is equipped with KIPLink, the innovative user interface based on WiFi technology, and, in addition, the physical LCD keyboard.		ALL

OPTIONS

Data Book
DB_ME_MECH-iF-G05 0411 - 0902_012024_EN
R513A

OPTIONS	DESCRIPTIONS	BENEFITS	AVAILABLE FOR MODELS
6194 LARGE KEYBOARD	The unit is equipped with the Large keyboard with a wide LCD display and led icons.		ALL
6195 7 INCH TOUCH SCREEN	The unit is equipped with the Touch interface, with a 7" WVGA colour display and a front USB port (WARNING: with outdoor temperature below 0°C the display response time may visibly increase).	The touch-screen's technology is characterized by an easy-to-access data, and it allows an effective graphical representation of the main figures protecting the access through 3 privilege levels.	ALL
3390 ANTICONDENSATE HEATER EL.BOARD			
3391 ELECTRIC HEATER ON EL. BOARD	Electrical heater fed directly from the unit, is automatically activated at temperatures internal QE below 30 ° C (off state at T higher than 40 ° C).	It avoids the risk of humidity condensation on the electrical panel.	ALL
1540 ON BOARD MULTI MANAGER			
1541 MM PRIORITY MASTER MM_PR	Multi Manager - Priority Master: integrated control of a group of chillers and chillers with free-cooling with up to 8 units with LAN logics and dynamic master. The unit is identified and parameterized as a Priority Master; therefore it is given preference in case of election of a new Master (in case of a failure of the current Master). At least one Priority Master must be present in the group. The maximum number of Priority Master units coincides with the number of connected units (up to 8). If you want to equip the group of chiller with auxiliary functions (e.g. 4-20 mA set point variation, pressure transducer for VPF system), each Priority Master requires auxiliary input signals. Consequently, for each Priority Master it is necessary to select these accessories from the price list and proceed with their wiring onsite. More details can be found in the data book and in the controls technical documentation.	It allows the management of a group of chillers and chillers with free-cooling (up to 8 units) via LAN with master/slave operating logic with dynamic master which always guarantees a back-up function to the network. The system makes other functions available such as load and stand-by unit management, resource use priority, unit start-up in sequence and group fast restart (when Fast Restart option is available). For more details refer to the dedicated section of the data book.	ALL
1542 MM NON PRIORITY MASTER MM_N-PR	Multi Manager - Non Priority Master: integrated control of a group of chillers and chillers with free-cooling with up to 8 units with LAN logics and dynamic master. The unit is identified and parameterized as a Non-Priority Master. Non-Priority Master units can become Masters (in case of a failure of the current Master) if there are no more Priority Master units available. In this case, the functions provided by the auxiliary signals are suspended (e.g. 4-20 mA set point variation, VPF); these signals can only be processed by Priority Master units. More details can be found in the data book and in the controls technical documentation.	It allows the management of a group of chillers and chillers with free-cooling (up to 8 units) via LAN with master/slave operating logic with dynamic master which always guarantees a back-up function to the network. The system makes other functions available such as load and stand-by unit management, resource use priority, unit start-up in sequence and group fast restart (when Fast Restart option is available). For more details refer to the dedicated section of the data book.	ALL

OPTIONS

Data Book
DB_ME_MECH-iF-G05 0411 - 0902_012024_EN
R513A

OPTIONS	DESCRIPTIONS	BENEFITS	AVAILABLE FOR MODELS
5920 MANAGEMENT & CONTROL SYSTEMS			
5922 ClimaPRO ModBUS RS485 - MID	This option includes the following devices on-board the unit panel: - MID certified network analyzer operating on ModBUS over RS-485 - Current transformers - Software release LA09 or later version.	This accessory allows to acquire the electrical data and the power absorbed by the unit and communicate with ClimaPRO via high level communication interface based on ModBUS over EIA RS-485. More specifically, the data collected are: power supply, current, frequency, power factor (cos), electrical power consumption, energy consumption. This specific energy meter model is MID certified and can therefore be used for billing applications. This option also ensures the compatibility between the units and ClimaPRO, thus allowing ClimaPRO to acquire all the main unit's operating variables and status by means of a high level communication interface to the controller installed onboard the unit panel.	ALL
5924 ENERGY METER FOR BMS	This option includes the following devices on-board the unit panel: - network analyzer with display operating on ModBUS protocol over RS-485 (without certification MID) - current transformers.	This accessory allows to acquire the electrical data and the power absorbed by the unit and send them via RS-485 bus to the BMS for energy metering.	ALL
5925 ENERGY METER FOR W3000	This option includes all following devices on-board the unit panel: - network analyzer with display, already cabled to unit's controller - current transformers.	This option allows to acquire the electrical data and the power absorbed by the unit. The figures are accessible through the unit's W3000 interface, and be sent to the BMS via several protocols by selecting the dedicated serial card in the option list.	ALL
4180 REMOTE CONNECTION ARRANGEMENT			
4181 SERIAL CARD MODBUS	Interface module for ModBUS protocols.	Allows integration with BMS operating with ModBUS protocol.	ALL
4182 SERIAL CARD FOR LONWORKS	Interface module for Echelon systems.	Allows integration with BMS operating with LonWorks protocols	ALL
4184 SERIAL CARD BACNET MS/TP RS485	Interface module for BACnet protocols.	Allows integration with BMS operating with BACnet protocol.	ALL
4185 SERIAL CARD FOR BACNET OVER IP	Interface module for BACnet OVER-IP protocols.	Allows to interconnect BACnet devices over Internet Protocol within wide-area networks.	ALL
4186 SERIAL CARD FOR KONNEX	Protocol for KNX system	Allows integration with BMS operating with KNX protocol	ALL
4188 SERIAL CARD MODBUS TCP/IP	Interface module for ModBus TCP/IP protocol	Allows integration with BMS operating with ModBus TCP/IP protocol.	ALL
4189 SERIAL CARD SNMP	Interface module for SNMP protocol	Allows integration with BMS operating with SNMP protocol.	ALL
1470 MULTIFUNCTION CARD			
1431 NIGHT MODE	The option includes a related controller expansion board and dedicated terminal block.	Night mode is a system setting to limit maximum noise level of the unit. Noise level is reduced limiting maximum compressor frequency and fan speed.	ALL

OPTIONS

ELCA_Engine ver.4.8.2.0

Data Book
DB_ME_MECH-IF-G05 0411 - 0902_012024_EN
R513A

OPTIONS	DESCRIPTIONS	BENEFITS	AVAILABLE FOR MODELS
1477 4962 + 4951 + 1431	The option includes a related controller expansion board and dedicated terminal block (it is necessary to install a 3 way valve).	Enables the functions corresponding to the indicated accessory codes.	ALL
4951 WITH HYDRAULIC DECOUPLER PROBE	Water temperature probe on hydraulic decoupler.	The pump activation can be set by parameter according to the water temperature on buffer tank measuring by the sensor (in the systems with the primary and secondary circuits separated by a hydraulic decoupler), thus bringing significant pump consumption reduction during unit's stand-by.	ALL
4962 U.L.C.F. - WITH VARIABLE WATER FLOW	Option to be selected with the unit with variable speed pump/s (4713,4714,4717,4718,4722,4723). The option includes a related controller expansion board and dedicated terminal block.	Guaranteed the start-up of the units with the option U.L.C. even when the critical working condition could generate an alarm. The controller can manage a 3 way mixing valve (not provided from MEHITS) by 0-10V signal for ensuring a dynamic control of the water temperature on user heat exchanger according to the operating limits allowed. This ensures the start-up and correct functioning of the unit into the envelope, also even critical whether condition.	ALL
6460 HPC SYSTEM ENABLING			
6461 HPC SOFTWARE ENABLING	MEHITS proprietary operating logics, which allows the optimization of a chilled water system for applications related to the world of data centers. It allows communication and perfect synergy in operation between water-cooled indoor units and chillers outdoor units. The patent pending logics guarantees optimal functioning of the chillers + CRAHs system, always guaranteeing maximum safety and reliability for the correct functioning of the servers. The algorithm guarantees significant energy savings thanks to the proprietary operating logics that optimizes the operation of the entire system.	It allows to optimize a chilled water system, for data center applications, consisting of indoor units and chillers.	ALL
3430 REFRIGERANT LEAK DETECTOR			
3431 REFRIG. LEAK DETECTOR	Refrigerant leak detection system, supplied factory mounted and wired in the electrical board. In case of leak detection it will raise an alarm.	It promptly detects gas leakages	ALL
3433 GAS LEAK CONTACT + COMPR. OFF	Refrigerant leak detection system, supplied factory mounted and wired in the electrical board. In case of leak detection it will raise an alarm and stop the unit.	It promptly detects gas leakages and stops the unit	ALL
820 FAN CONTROL			
818 OVERSIZED EC FANS	Fans with oversized EC motor	Extends the operating limits of the unit. Further information in the dedicated databook section.	ALL

OPTIONS

Data Book
DB_ME_MECH-IF-G05 0411 - 0902_012024_EN
R513A

OPTIONS	DESCRIPTIONS	BENEFITS	AVAILABLE FOR MODELS
1670 MEASURES LOW EVAP TEMPERATURE			
1671 "LT" KIT FOR LOW EVAP. TEMPER.	Kit for low condenser leaving water temperature. NOTE: the adoption of "kit LT" modifies the unit performance in all the operating range; refer to the selection software to have the correct technical data.	The accessory is required for applications with low evaporating temperature (process applications).	ALL
1400 HP AND LP GAUGES			
1401 HP AND LP GAUGES	High and low pressure gauges	Allows immediate reading of the pressure values on both low and high pressure circuits	ALL
2880 EVAPORATOR WATER DELTA 10°C			
2881 EVAPORATOR FOR DELTA T>8°C	Evaporator dedicated to work with low primary circuit waterflow.	The heat exchange takes place under efficient conditions and the favorable sizing of primary pumps allows a considerable pumping energy saving.	ALL
2630 INSULATION ON EXCHANGERS			
2631 DOUBLE INSULATION ON EXCHANGERS	Thermal insulation in closed-cell flexible elastomeric foam (FEF) of 16 mm coupled with a 3 mm layer of reticulated foam in PE and an exterior embossed finishing PE film. This option is mandatory if the unit is supposed to work with outdoor temperature below -10°C.	Reduces heat losses and prevent from condensate problems.	ALL
2633 DOUBLE INSULATION ON EXCH+PIPES+PUMPS	Thermal insulation on heat exchangers in closed-cell flexible elastomeric foam (FEF) of 16 mm coupled with a 3 mm layer of reticulated foam in PE and an exterior embossed finishing PE film. Thermal insulation on pumps and pipes in closed-cell reticulated foam in PE of 20 mm. This option is mandatory if the unit is supposed to work with outdoor temperature below -10°C.	Reduces heat losses and prevent from condensate problems.	ALL
1800 EVAPORATOR WATER FLOW SWITCH			
1801 EVAPORATOR WATER FLOW SWITCH	Flow switch with stainless scoop AISI 316L and IP65 protection suitable for installation in industrial plant pipes. It should be installed in a straight pipe without filters, valves, etc., long at least 5 times its diameter, both upstream and downstream.	Signaling of lack of or excessive reduction of flow, it generates an alarm that is in automatic or manual reset depending on n ° alarms per hour and the maximum time of operation of the pump under conditions of low flow rate.	ALL
1803 ELECTRONIC EV H2O FLOW SWITCH	Electronic flow switch in stainless steel with IP67 protection and 2 digital outputs, suitable for installation in industrial plant pipes. It's supplied with a temperature sensor, a led bar display and a setting button. It must be installed in a straight pipe section without filters, valves, elbows, etc., at least 5 times the pipe diameter in length, both upstream and downstream from the switch for reliable measurement.	It measures the heat dissipation between two points and allows to calculate the flow rate of the fluid using the calorimetric measuring principle. It can provide different output depending on whether the stream exceeds the SP1 or SP2 set switch points.	ALL
1900 COMPRESSOR SUCTION VALVE			
1901 COMPRESSOR SUCTION VALVE	Shut-off valve on compressor's suction circuit.	Simplifies maintenance activities	ALL

OPTIONS	DESCRIPTIONS	BENEFITS	AVAILABLE FOR MODELS
4970 FLOW METER x THERMAL ENERGY :			
4975 FLOW METER DN100 PN16 4-20mA	<p>Flow meter, supplied loose, not installed, for water flow measurement. The device must be mounted on the supply line. The supply does not provide for an adaptation between the diameter of the flow meter and that of the water supply pipe, if these are different.</p> <p>Different flow meters are available depending on the diameter, which allow different flow ranges: - 4971 - FLOW METER ND 40 (1"1/2) - 4972 - FLOW METER ND 50 (2") - 4973 - FLOWMETER ND 65 (2"1/2) - 4974 - FLOW METER ND 80 (3") - 4975 - FLOW METER ND 100 (4") - 4976 - FLOW METER ND 125 (5") - 4977 - FLOWMETER ND 150 (6") - 4978 - FLOWMETER ND 200 (8")</p>		ALL
4976 FLOW METER DN125 PN16 4-20mA	<p>Flow meter, supplied loose, not installed, for water flow measurement. The device must be mounted on the supply line. The supply does not provide for an adaptation between the diameter of the flow meter and that of the water supply pipe, if these are different.</p> <p>Different flow meters are available depending on the diameter, which allow different flow ranges: - 4971 - FLOW METER ND 40 (1"1/2) - 4972 - FLOW METER ND 50 (2") - 4973 - FLOWMETER ND 65 (2"1/2) - 4974 - FLOW METER ND 80 (3") - 4975 - FLOW METER ND 100 (4") - 4976 - FLOW METER ND 125 (5") - 4977 - FLOWMETER ND 150 (6") - 4978 - FLOWMETER ND 200 (8")</p>		ALL
4978 FLOW METER DN200 PN16 4-20mA	<p>Flow meter, supplied loose, not installed, for water flow measurement. The device must be mounted on the supply line. The supply does not provide for an adaptation between the diameter of the flow meter and that of the water supply pipe, if these are different.</p> <p>Different flow meters are available depending on the diameter, which allow different flow ranges: - 4971 - FLOW METER ND 40 (1"1/2) - 4972 - FLOW METER ND 50 (2") - 4973 - FLOWMETER ND 65 (2"1/2) - 4974 - FLOW METER ND 80 (3") - 4975 - FLOW METER ND 100 (4") - 4976 - FLOW METER ND 125 (5") - 4977 - FLOWMETER ND 150 (6") - 4978 - FLOWMETER ND 200 (8")</p>		ALL

OPTIONS

ELCA_Engine ver.4.8.2.0

Data Book
DB_ME_MECH-iF-G05 0411 - 0902_012024_EN
R513A

OPTIONS	DESCRIPTIONS	BENEFITS	AVAILABLE FOR MODELS
990 CONDENSING COIL			
876 E-COATING MICROCHANNEL COILS	The heat exchanger is completely treated by electrolysis so as to create a protective layer of epoxy polymer on the surface, with the following characteristics: - over 3120 hours of salt spray protection as per ASTM G85-02 A3 (SWAAT); - polyurethane surface protection against UV rays.	Provides a very high resistance against corrosion, also in very aggressive environments. For further information please refer to the Guidelines "Finned coil heat exchangers and protection against corrosion", available in the download section of the website www.melcohit.com/EN/Download/Corporate/GUIDELINES or contact our sales department.	ALL
879 COPPER/ALUMINIUM COILS	Finned coil heat exchanger made from suitably-spaced copper tubes and aluminum fins designed to ensure maximum heat exchange efficiency.	Provide a good resistance against corrosion. For further information please refer to the Guidelines "Finned coil heat exchangers and protection against corrosion", available in the download section of the website www.melcohit.com/EN/Download/Corporate/GUIDELINES or contact our sales department.	ALL
894 Cu PIPES/PREPAINTED ALL. FINS	Finned coil heat exchanger made from copper tubes and aluminum fins with chemical cleaning treatment to remove impurities, and then coated with protective paint with the following characteristics: - fins treated with protective polyester resin paint; - over 1000 hours of salt spray protection as per ASTM B117 (fins without cross and protected edges); - excellent resistance to UV rays.	Provide a good resistance against corrosion. For further information please refer to the Guidelines "Finned coil heat exchangers and protection against corrosion", available in the download section of the website www.melcohit.com/EN/Download/Corporate/GUIDELINES or contact our sales department.	ALL
895 FIN GUARD SILVER TREATM	Copper-aluminum heat exchanger coils with polyurethane paint Fin Guard Silver SB. Coil completely coated by a protective layer of polyurethane paint with the following characteristics: - polyurethane paint with metallic emulsion; - over 3000 hours of salt spray protection as per ASTM B117; - excellent resistance to UV rays; - high-pressure spray painting system.	Provides a very high resistance against corrosion, also in very aggressive environments. For further information please refer to the Guidelines "Finned coil heat exchangers and protection against corrosion", available in the download section of the website www.melcohit.com/EN/Download/Corporate/GUIDELINES or contact our sales department.	ALL
4700 EV - HYDRONIC MODULE			
4711 EV - 2 PUMPS 2P LH (FIX SPEED)	Evaporator hydronic module, compatible with constant flow control. The unit is provided with 2 fixed speed pumps, with 2-pole motor. Residual head of 100 kPa approximately. The pumps are controlled in duty/standby, with running hours equalization and changeover on device failure. Specifications and characteristic curves are available in the dedicated bulletin section.	The hydronic module includes the pumps and the main water circuit components, thus optimizing hydraulic and electrical installation space, time and costs.	ALL

OPTIONS

ELCA_Engine ver.4.8.2.0

Data Book
DB_ME_MECH-iF-G05 0411 - 0902_012024_EN
R513A

OPTIONS	DESCRIPTIONS	BENEFITS	AVAILABLE FOR MODELS
4712 EV - 2 PUMPS 2P HH (FIX SPEED)	Evaporator hydronic module, compatible with constant flow control. The unit is provided with 2 fixed speed pumps, with 2-pole motor. Residual head of 200 kPa approximately. The pumps are controlled in duty/standby, with running hours equalization and changeover on device failure. Specifications and characteristic curves are available in the dedicated bulletin section.	The hydronic module includes the pumps and the main water circuit components, thus optimizing hydraulic and electrical installation space, time and costs.	ALL
4714 EV - RELAY 2 PUMPS + 0-10V SIG	Evaporator hydronic module, compatible with constant or variable flow control. The unit is provided with 2 relays and a 0-10V signal terminal to control the activation and the speed of 2 external variable speed pump. The pumps are controlled in duty/standby, with running hours equalization and changeover on device failure.	The hydronic module controls the external pumps with the unit controller logic.	ALL
4722 EV - 2 PUMPS 2P LH (VAR SPEED)	Evaporator hydronic module, compatible with constant or variable flow control. The unit is provided with 2 variable speed pumps, with 2-pole motor. Residual head of 100 kPa approximately. The pumps are controlled in duty/standby, with running hours equalization and changeover on device failure. Specifications and characteristic curves are available in the dedicated bulletin section.	The hydronic module includes the pumps and the main water circuit components, thus optimizing hydraulic and electrical installation space, time and costs.	ALL
4723 EV - 2 PUMPS 2P HH (VAR SPEED)	Evaporator hydronic module, compatible with constant or variable flow control. The unit is provided with 2 variable speed pumps, with 2-pole motor. Residual head of 200 kPa approximately. The pumps are controlled in duty/standby, with running hours equalization and changeover on device failure. Specifications and characteristic curves are available in the dedicated bulletin section.	The hydronic module includes the pumps and the main water circuit components, thus optimizing hydraulic and electrical installation space, time and costs.	ALL
4860 EV - PRIMARY FLOW CONTROL			
4862 EV - CONSTANT FLOW (PARAMETER)	Evaporator water flow control (plant primary circuit): constant flow (parameter set). Compatible with hydronic modules with modulating regulation devices (0-10V signal) or with variable speed pumps (codes: 4713, 4714, 4715, 4716, 4717, 4718, 4719, 4721, 4722, 4723 - hydronic modules availability depends on unit model).	The unit is set up to operate with a constant water flow in the heat exchanger (plant primary circuit). The unit controller manages the pump activation to reduce pump consumption. The pump speed is adjusted via 0-10V signal. The option provides the possibility to set the pump speed with a controller parameter. Once set, the speed pump remains constant until the next parameter adjustment. The parameter set constant flow control is useful during the unit installation and commissioning, to adjust water flow and pressure head according to the real plant characteristics.	ALL

OPTIONS	DESCRIPTIONS	BENEFITS	AVAILABLE FOR MODELS
4864 EV – VPF (w/o DP)(SU, MM_PR)	Evaporator water flow control (plant primary circuit): variable flow (delta P control). Only for single unit systems or unit with option 1541 (Multi Manager - Priority Master) if available. Compatible with hydronic modules with modulating regulation devices (0-10V signal) or with variable speed pumps (codes: 4713, 4714, 4715, 4716, 4717, 4718, 4719, 4721, 4722, 4723 - hydronic modules availability depends on unit model). The option includes: differential pressure transducer on the unit's heat exchanger and related controller expansion board, controller expansion board to read the plant side differential pressure transducer (4-20mA signal) and manage the hydraulic by-pass valve opening (0-10V signal). Compulsory equipment, supplied by others: plant side differential pressure transducer, plant side hydraulic by-pass valve.	The unit is set up to operate with a variable water flow in the heat exchanger (plant primary circuit). The unit controller manages the pump activation to reduce pump consumption. The pump speed is adjusted via 0-10V signal. The option provides a pump speed management based on the VPF (Variable Primary Flow) function. It keeps the delta P constant on the plant side (primary circuit), thus bringing significant pump consumption reduction during part load operation. The VPF function is applicable in systems with only the primary circuit. Further information available in the dedicated bulletin section.	ALL
4865 EV – VPF (w DP)(SU, MM_PR)	Evaporator water flow control (plant primary circuit): variable flow (delta P control). Only for single unit systems or unit with option 1541 (Multi Manager - Priority Master) if available. Compatible with hydronic modules with modulating regulation devices (0-10V signal) or with variable speed pumps (codes: 4713, 4714, 4715, 4716, 4717, 4718, 4719, 4721, 4722, 4723 - hydronic modules availability depends on unit model). The option includes: differential pressure transducer on the unit's heat exchanger and related controller expansion board, plant side differential pressure transducer (installation by others), controller expansion board to read the plant side differential pressure transducer (4-20mA signal) and manage the hydraulic by-pass valve opening (0-10V signal). Compulsory equipment, supplied by others: plant side hydraulic by-pass valve.	The unit is set up to operate with a variable water flow in the heat exchanger (plant primary circuit). The unit controller manages the pump activation to reduce pump consumption. The pump speed is adjusted via 0-10V signal. The option provides a pump speed management based on the VPF (Variable Primary Flow) function. It keeps the delta P constant on the plant side (primary circuit), thus bringing significant pump consumption reduction during part load operation. The VPF function is applicable in systems with only the primary circuit. Further information available in the dedicated bulletin section.	ALL

OPTIONS	DESCRIPTIONS	BENEFITS	AVAILABLE FOR MODELS
<p>4866 EV – VPF (M3000, CPRO, MM_N-PR)</p>	<p>Evaporator water flow control (plant primary circuit): variable flow (delta P control). Only for multi-unit systems with external controller (Manager3000 or ClimaPRO) or unit with option 1542 (Multi Manager - Non Priority Master) if available. Compatible with hydronic modules with modulating regulation devices (0-10V signal) or with variable speed pumps (codes: 4713, 4714, 4715, 4716, 4717, 4718, 4719, 4721, 4722, 4723 - hydronic modules availability depends on unit model). The option includes: differential pressure transducer on the unit's heat exchanger and related controller expansion board. It shall be the customer responsibility to configure the multi-unit control system (Manager3000, ClimaPRO or Multi Manager Priority Master) with option VPF.</p>	<p>The unit is set up to operate with a variable water flow in the heat exchanger (plant primary circuit). The unit controller manages the pump activation to reduce pump consumption. The pump speed is adjusted via 0-10V signal. The option provides a pump speed management based on the VPF (Variable Primary Flow) function. It keeps the delta P constant on the plant side (primary circuit), thus bringing significant pump consumption reduction during part load operation. The VPF function is applicable in systems with only the primary circuit. Further information available in the dedicated bulletin section.</p>	<p>ALL</p>
<p>4867 EV - VPF.D (SU, MM_PR)</p>	<p>Evaporator water flow control (plant primary circuit): variable flow (delta T control). Only for single unit systems or unit with option 1541 (Multi Manager - Priority Master) if available. Compatible with hydronic modules with modulating regulation devices (0-10V signal) or with variable speed pumps (codes: 4713, 4714, 4715, 4716, 4717, 4718, 4719, 4721, 4722, 4723 - hydronic modules availability depends on unit model). The option includes: 2 plant side NTC temperature sensors (installation by others).</p>	<p>The unit is set up to operate with a variable water flow in the heat exchanger (plant primary circuit). The unit controller manages the pump activation to reduce pump consumption. The pump speed is adjusted via 0-10V signal. The option provides a pump speed management based on the VPF.D (Variable Primary Flow with Decoupler) function. It keeps the delta T constant on the plant side (primary circuit), thus bringing significant pump consumption reduction during part load operation. The VPF.D function is applicable in systems with the primary and secondary circuits separated by a hydraulic decoupler. Further information available in the dedicated bulletin section.</p>	<p>ALL</p>
<p>4868 EV - VPF.D(M3000, CPRO, MM_N-PR)</p>	<p>Evaporator water flow control (plant primary circuit): variable flow (delta T control). Only for multi-unit systems with external controller (Manager3000 or ClimaPRO) or unit with option 1542 (Multi Manager - Non Priority Master) if available. Compatible with hydronic modules with modulating regulation devices (0-10V signal) or with variable speed pumps (codes: 4713, 4714, 4715, 4716, 4717, 4718, 4719, 4721, 4722, 4723 - hydronic modules availability depends on unit model). It shall be the customer responsibility to configure the multi-unit control system (Manager3000, ClimaPRO or Multi Manager - Priority Master) with option VPF.D.</p>	<p>The unit is set up to operate with a variable water flow in the heat exchanger (plant primary circuit). The unit controller manages the pump activation to reduce pump consumption. The pump speed is adjusted via 0-10V signal. The option provides a pump speed management based on the VPF.D (Variable Primary Flow with Decoupler) function. It keeps the delta T constant on the plant side (primary circuit), thus bringing significant pump consumption reduction during part load operation. The VPF.D function is applicable in systems with the primary and secondary circuits separated by a hydraulic decoupler. Further information available in the dedicated bulletin section.</p>	<p>ALL</p>

OPTIONS

Data Book
DB_ME_MECH-iF-G05 0411 - 0902_012024_EN
R513A

OPTIONS	DESCRIPTIONS	BENEFITS	AVAILABLE FOR MODELS
3370 D - HYDRONIC MODULE			
3371 D - RELAY 1 PUMP (ON/OFF)	Desuperheater hydronic module. The unit is provided with 1 relay to control the activation of 1 external pump via single ON/OFF signal.	The hydronic module allows to control the external pumps with the unit controller logic. The partial heat recovery pumps are activated only when heat recovery is actually possible: compressors on, hot storage tank temperature lower than set-point and than compressor outlet gas temperature. The option minimizes pump consumption.	ALL
2910 HYDRAULIC CONNECTIONS			
2911 FLANGED HYDRAULIC CONNECTIONS	Grooved coupling with flanged counter-pipe user/source side.		ALL
2430 PIPING KIT ANTIFREEZE HEATER			
2432 ANTIFREEZE PIPING, PUMPS	Electrical heaters on pipes and other hydraulic unit's components. This option is mandatory if the unit is supposed to work with outdoor temperature below 0°C. Only for units provided with on-board pumps.	It protects the unit against ice formation on its hydraulic components.	ALL
2340 UNIT ENCLOSURE			
2315 NOISE REDUCER	The option includes the reduction of the rotational speed of the fans and a dedicated coating of the whole refrigerant circuit and pumps (if any).	The dedicated fans' speed calibration together with the soundproofing of the most critical components permit a significant noise reduction (for the precise performance of the unit with the Noise Reducer kit please refer to the selection software).	ALL
2020 ANTI-INTRUSION GRILLS			
2021 ANTI-INTRUSION GRILLS	Anti-intrusions grills	Avoid the intrusion of solid bodies into the unit's structure.	ALL
2100 ANTIVIBRATION MOUNTING			
2101 RUBBER TYPE ANTIVIBR.MOUNTING			ALL
2102 SPRING TYPE ANTIVIBR.MOUNTING			ALL
1970 LONG DISTANCE TRANSPORTATION			
1971 REINFORCING BARS	Bars used to reinforce the structure	Improve resistance during long transportation	ALL
9970 PACKING			
9966 NYLON PACKING	Unit covered with nylon		ALL
9979 CONTAINER PACKING	Unit provided with container slides and covered with nylon		ALL

5.2 Options - Additional information

1541 – Multi Manager – Priority Master

1542 – Multi Manager – Non-Priority Master

These options are not compatible with option:
5922 - ClimaPRO ModBUS RS485 – MID

6461 - HPC

This option requires the accessories Multi Manager (options 1541 or 1542) and KIPlink (options 6196* or 1441* or 1442* or 1443* or 1444*)
(*if available)

6173 - Smart current limit

This option gives the possibility to control the maximum current absorbed by the unit.
It keeps the absorbed current (and power) below a predetermined value.

This accessory necessarily requires one of the following options:

5922 - ClimaPRO ModBUS RS485 - MID

5924 - Energy meter for BMS

5925 - Energy meter for W3000+

1019 - Heat exchangers AS1210 certified

The certification is available for the evaporator only. NSW certification for recovery heat exchanger (versions -D) is available.

1431 – Night mode

With factory settings (12/7, 35 °C conditions and 74% of the nominal capacity), the noise reduction achieved is:

-5 dB(A) for standard unit.

-4 dB(A) for -NR kit and -SL version.

4501 – Fast restart (UPS excluded)
4502 – Fast restart (UPS included)

Option 4502 - Fast Restart (UPS included) ensures that the controller is kept powered for more than 20 minutes.

Following a blackout, the fast restart option allows a quick restart of the unit and a full load in less time than a standard restart.

The first compressor is restarted 21 seconds after the power has been restored.
 The full load of the unit is reached within 170 seconds of the power reset, for a single-compressor unit, and 180 seconds of the power reset for a 2-compressor unit.
 It is possible to make up to 12 fast restarts in an hour.

These times provide a minimum time during which the compressor must remain switched off.
 The minimum time during which the compressor must remain switched off must be 60 seconds.

1561 – Double power supply (ATS)

This option excludes the general lock door isolator. In substitution, a button to disconnect the unit from the power is present.



The unit equipped with ATS does not have a power switch but a button to disconnect the unit from the power.

1801 - Evaporator water flow switch
1803 - Electronic evaporator flow switch

The accessory is supplied loose.

3371 - D - Relay 1 pump (ON/OFF)

The operating diagram of the device is provided below:

Note: the thermostats T1, T2 and T3 are supplied cabled. It is the customer’s responsibility to place the temperature probes in the storage tank.

The option leads to an extension of the lead time, contact our sales department for information

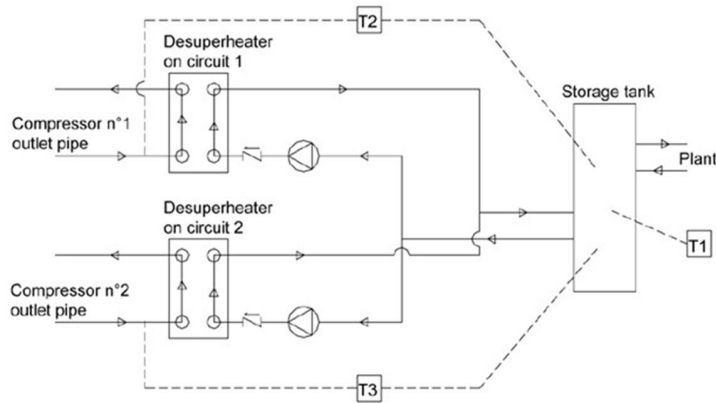

Operating diagram of the "partial heat recovery control" function for a unit with two refrigerant circuits.

- 4711 - EV - 2 PUMPS 2P LH (FIX SPEED)**
- 4712 - EV - 2 PUMPS 2P HH (FIX SPEED)**
- 4722 - EV - 2 PUMPS 2P LH (VAR SPEED)**
- 4723 - EV - 2 PUMPS 2P HH (VAR SPEED)**

The pump group may increase the unit’s length up to 1250 mm. Refer to the selection software for more information.

The sizes involved are 0411 and 0802.

- 5821 - Thermal energy meter**
- 4971 - Flow meter ND40**
- 4972 - Flow meter ND50**
- 4973 - Flow meter ND65**
- 4974 - Flow meter ND80**
- 4975 - Flow meter ND100**
- 4976 - Flow meter ND125**
- 4977 - Flow meter ND150**
- 4978 - Flow meter ND200**

There is a bond of mutual inclusion between the accessories "thermal energy meter" and "flow meter". The combination of the two accessories allows you to view the cooling capacity produced by the unit. This data is available both to onboard controller units and to BMS (if any).
 Communication is via Modbus RS485 protocol. Protocols other than this are available as custom execution. Additional analog or digital outputs are available as custom solutions.
 The correct selection of the flow meter depends on the working conditions of the unit. Flow meters with different diameters allow to cover different range of flow. Verify that the flowmeter selected is able to cover the operating water flow range of the unit.

The installation of these accessories provides that:

- where space is available, the thermal energy meter shall be installed inside the electrical panel. If the space is not sufficient, it will still be installed on the unit;
- the two temperature probes and the flow meter will be supplied loose. The flow meter and a probe will be installed on the water supply of the unit, while the second probe, on the return. Any adaptation between the diameter of the flow meter and the diameter of the delivery pipe is not provided for in the delivery.

OPTIONS		Pipe internal diameter		Minimum water flow rate		Maximum water flow rate	
		ND [pollici]	ND [mm]	Q _{min} [m ³ /h]	Q _{min} [l/s]	Q _{max} [m ³ /h]	Q _{max} [l/s]
4971	FLOW METER ND 40	1"1/2	40	4,5	16,3	13,6	48,9
4972	FLOW METER ND 50	2"	50	7,1	25,4	21,2	76,3
4973	FLOW METER ND 65	2"1/2	65	11,9	43,0	35,8	129,0
4974	FLOW METER ND 80	3"	80	18,1	65,1	54,3	195,4
4975	FLOW METER ND 100	4"	100	28,3	101,8	84,8	305,4
4976	FLOW METER ND 125	5"	125	44,2	159,0	132,5	477,1
4977	FLOW METER ND 150	6"	150	63,6	229,0	190,9	687,1
4978	FLOW METER ND 200	8"	200	113,1	407,1	339,3	1221,4

Minimum and maximum water flow rates for each available flow meter

818 - Oversized EC fans

This option allows to provide an available static pressure at the air discharge of the fans. Units with this option are suitable to win maximum air pressure drop of 150 Pa. From 100 Pa to 150 Pa there is a reduction of the maximum outdoor air temperature admitted. 150 Pa are available at 46°C for all versions.

MECH-iF-G05		FLI	FLA
Version	Size	[kW]	[kW]
- SL	0411	182,8	284,4
- SL	0802	335,5	520,8
- SL	0902	371,2	577,6

*Electrical data valid for standard units equipped with oversized EC fans.
 Voltage tolerance: 10%
 Maximum voltage unbalance: 2%*

1540 - LAN Multi Manager

Up to 8 units (chillers or free-cooling chillers, with the same firmware version) can communicate via serial connection.

All the group functions are implemented with master/slave logic, with dynamic master.

Hereunder is a brief description of the main group functions, further details are available in the dedicated user manual.

- Load management

There are two possible load management logics: load sharing and sequencing.

- Load sharing: the load is distributed equally among the active units of the group.

- Sequencing: the units are activated one after the other. When the first unit is saturated (all the available resources are used), the second unit is activated, and so forth until the load is fully covered.

- Dynamic master

In case of disconnection of the master unit, a new master is automatically elected among the other units, and the group functions remain active. The dynamic master function grants a backup solution to the net, overcoming the single point of failure typical of the static master architecture. Besides, it is possible to set the "master succession priority": in case of the master unit disconnection, the new master is elected among the units set as priority.

- Stand-by unit management

It is possible to set the number of unit that remain in stand-by, the load will be managed (with load sharing or sequencing) among the other units of the group. The stand-by unit rotation is automatic, according to the running hours equalization. A stand-by unit is immediately activated in case of total failure or disconnection of one of the active units of the group, or in case the water temperature exceeds the safety threshold.

- Restart in sequence

After a power black-out, this group function coordinates the compressor activation time of the different units and prevents from dangerous current picks due to simultaneous start-ups. Besides, it is possible to set the activation sequence of the units.

- Resource priority management

To make the most of the available cooling resources, it is possible to set the usage priority of each unit. The load management function will be adjusted accordingly. When available, the free-cooling is always given priority and is fully exploited before activating any compressor. Then the activation of the compressors follows the priority level assigned to the units.

- Auxiliary input

The auxiliary inputs are applied at a group level:

- 4-20 mA: remote set-point adjustments (analog input).

- Double set-point: remote switch between 2 set-points (digital input).

- Demand limit: remote signal to limit the unit's activable resources (digital input).

6461 – HPC

HPC is the new advanced and fully integrated control function designed by MEHITS for hydronic plant optimization. It connects MEHITS chillers and indoor CRAH units without any external devices.

INFRASTRUCTURE

The HPC function is based on LAN groups and the KIPLink network (KIPLAN).

- Every indoor and outdoor unit must be equipped with KIPLink.
- Every outdoor unit must be equipped with Multi Manager.
- HPC supports up to 20 LAN groups of indoor air conditioners (max 15 units per group) and 1 LAN group of outdoor chillers (max 8 units).
- HPC requires a KIPLAN (KIPLink network) made up of one unit per each LAN group.
- The result is a KIPLAN made of 1 chiller unit (KIP Master), and up to 20 indoor units (KIP Clients).
- KIPLAN network allows HPC data communication between the different LAN groups (indoor and outdoor).

KIPLink allows direct access to all HPC variables and parameters with devoted menus and pages. The most important parameters are also available on the Compact/Large Keyboard.

Further information is available in the dedicated Manuals (W3000+, Evolution+, KIPLink).

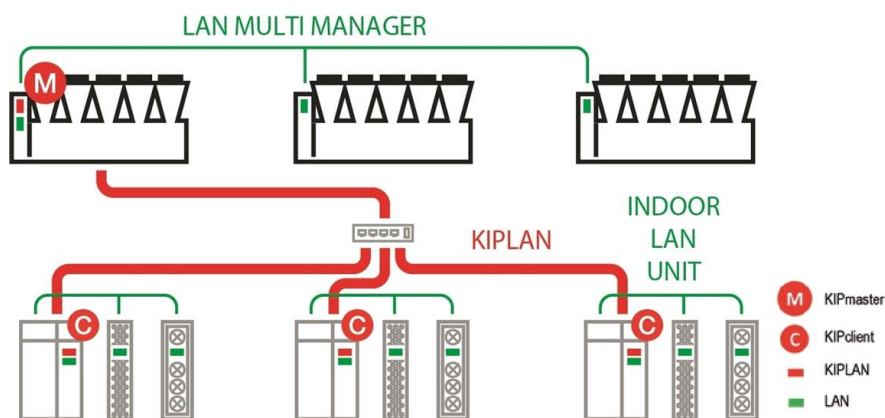

WORKING LOGICS

The HPC control logics enhance the system efficiency leveraging on partial loads, redundant units, and favourable ambient conditions.

HPC acts on time intervals. The time lapse between each HPC action can be set from 1 to 500 minutes. The time left until the next action is visible in the KIPlink group interface section.

According to the instantaneous operating conditions detected in the chilled water system, HPC regulates: the chillers' set-point, the pumps' speed, and the indoor air conditioners' valves and fans.

The main variables taken into consideration are:

- Cooling demand of each indoor unit group (room temperature, fans' speed, valve opening),
- Chilled water temperature,
- Pumps' speed,
- Chillers' group operating status (outdoor air temperature, FC availability)

The highest benefits are achieved in systems with VSD pumps and free-cooling chillers.

IT cooling load satisfaction is paramount. HPC always gives priority to room cooling dependability. Therefore, actions are taken on the basis of the indoor unit groups' status.

There are 4 operating modes, in order of priority:

1. Reset

When the cooling demand of at least one group of indoor units suddenly increases.

HPC contribution is reset and suspended until the Reset message is active.

The system immediately increases the cooling capacity.

2. Reduce

When the cooling demand of at least one group of indoor units slightly increases.

HPC contribution is reduced. The system increases the cooling capacity.

3. Optimization On

When the cooling demand of all groups of indoor units remains stable or decreases.

HPC optimizes the system by increasing its contribution.

4. No Action

When the cooling demand of all groups of indoor units remains stable or decreases, but HPC has already pushed the system to the best performance achievable in the current conditions.

No further action is taken.

Further information is available in the dedicated Manuals (W3000+, Evolution+).

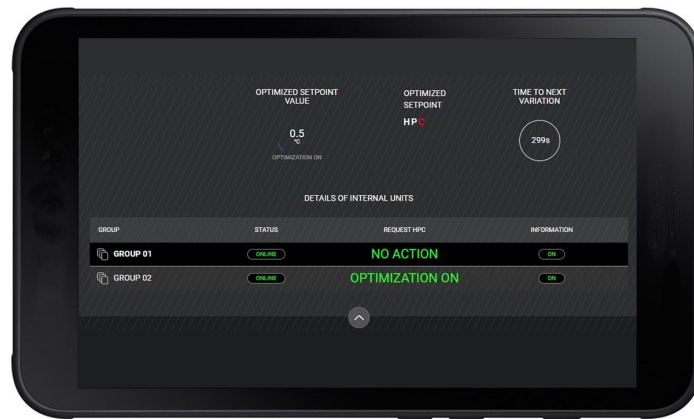

- ✓ **PLUS:**
 - Fully in house developed and patent pending
 - Completely integrated, no need for any external devices
 - Based on proprietary logics and devices (Multi Manager, KIPlink)
 - Energy simulations, comparisons, and payback analysis available on ELCA software
 - Ideal to complete the package of a MEHITS chilled water system (chillers and CRAHs)

Chiller Plant Control with Active Optimization System

ClimaPRO+ System Manager

ClimaPRO+ System Manager represents the state-of-the-art platform for chiller plant management and control.

ClimaPRO+ ensures to actively optimize the entire chiller plant by managing and adjusting each component directly involved in the production and the distribution of the heating and the cooling energies, therefore involving chillers and heat pumps, pumping groups as well as the source-side devices like, for example, the cooling towers.

In particular, ClimaPRO+ measures in real-time all the operating variables from the field, for each individual device and each of the main system branches, by using serial communication lines as well as dedicated analogue signals.

The acquired data are then compared with the design data of each single unit at any different working conditions, thus allowing to implement control strategies based on dynamic algorithms which take into account the real operating conditions.

On the basis of these values, an advanced diagnostic module also allows to assess the level of efficiency for each individual unit, translating data into easy-to-read information in order to simplify and optimize the maintenance activities.

The "Chart Builder" software module allows to display the trends of the main operating variables. The "Reporting" module allows to send reports to selected users, including data and system's status of the main devices as well as to perform calculation of the energy indexes for each single unit and for the entire chiller plant.

The accessibility to ClimaPRO+ System Manager is ensured by an integrated web server that makes it visible from any computer equipped with a web browser, either locally or remotely.



6 GENERAL TECHNICAL DATA

Data Book
DB_ME_MECH-IF-G05 0411 - 0902_012024_EN
R513A

[SI System]

MECH-IF-G05		0411	0802	0902	
Power supply		V/ph/Hz	400/3/50	400/3/50	400/3/50
PERFORMANCE					
COOLING ONLY (GROSS VALUE)					
Cooling capacity	(1)	kW	414,4	814,7	921,1
Total power input	(1)	kW	133,7	249,6	289,6
EER	(1)	kW/kW	3,099	3,264	3,181
COOLING ONLY (EN14511 VALUE)					
Cooling capacity	(1)(4)	kW	413,9	814,1	920,4
EER	(1)(4)	kW/kW	3,060	3,220	3,150
COOLING WITH PARTIAL RECOVERY					
Cooling capacity	(5)	kW	430,0	845,3	955,6
Total power input	(5)	kW	129,3	241,6	280,3
Desuperheater heating capacity	(5)	kW	110,2	204,6	237,3
EXCHANGERS					
HEAT EXCHANGER USER SIDE IN COOLING					
Water flow	(1)	l/s	19,82	38,96	44,05
Pressure drop at the heat exchanger	(1)(4)	kPa	54,1	50,9	40,7
PARTIAL RECOVERY USER SIDE IN REFRIGERATION					
Water flow	(1)	l/s	5,320	9,877	11,45
Pressure drop at the heat exchanger	(1)	kPa	30,8	26,6	35,7
PERFORMANCE					
COOLING ONLY (GROSS VALUE)					
16°C/10°C					
Cooling capacity	(2)	kW	449,4	882,6	999,0
Total power input	(2)	kW	139,1	258,4	301,6
EER	(2)	kW/kW	3,231	3,416	3,312
23°C/15°C					
Cooling capacity	(3)	kW	514,0	1005	1139
Total power input	(3)	kW	149,7	273,9	324,5
EER	(3)	kW/kW	3,434	3,669	3,510
EXCHANGERS					
16°C/10°C					
Water flow	(2)	l/s	17,92	35,20	39,84
Pressure drop at the heat exchanger	(2)	kPa	45,6	42,8	34,3
23°C/15°C					
Water flow	(3)	l/s	15,40	30,10	34,13
Pressure drop at the heat exchanger	(3)	kPa	35,2	32,8	26,4
REFRIGERANT CIRCUIT					
Compressors nr.		N°	1	2	2
Number of capacity steps		N°	0	0	0
No. Circuits		N°	1	2	2
Regulation			STEPLESS	STEPLESS	STEPLESS
Min. capacity step		%	24	13	13
Refrigerant			R513A	R513A	R513A
Theoretical refrigerant charge		kg	89,0	170	199
Oil charge		kg	11,0	22,0	22,0
Rc (ASHRAE)	(6)	kg/kW	0,22	0,21	0,22
FANS					
Quantity		N°	6	12	14
Air flow		m³/s	32,40	64,80	75,60
Total fans power input		kW	10,20	20,40	23,80
NOISE LEVEL					
Total sound Pressure	(7)	dB(A)	64	65	70
Total sound power level in cooling	(8)(9)	dB(A)	96	98	103
SIZE AND WEIGHT					
A	(10)	mm	4150	7900	9150
B	(10)	mm	2260	2260	2260
H	(10)	mm	2500	2500	2500
Operating weight	(10)	kg	4350	8150	8610

Notes:

1 Plant (side) cooling exchanger water (in/out) 12,00°C/7,00°C; Source (side) heat exchanger air (in) 35,0°C.
2 Plant (side) cooling exchanger water (in/out) 16,00°C/10,00°C; Source (side) heat exchanger air (in) 35,0°C.
3 Plant (side) cooling exchanger water (in/out) 23,00°C/15,00°C; Source (side) heat exchanger air (in) 35,0°C.
4 Values in compliance with EN14511
5 Plant (side) cooling exchanger water (in/out) 12,00°C/7,00°C; Source (side) heat exchanger air (in) 35,0°C; Plant (side) heat exchanger recovery water (in/out) 40,00°C/45,00°C.

6 Rated in accordance with AHRI Standard 550/590
7 Average sound pressure level at 10m distance, unit in a free field on a reflective surface; non-binding value calculated from the sound power level.
8 Sound power on the basis of measurements taken in compliance with ISO 9614.
9 Sound power level in cooling, outdoors.
10 Unit in standard configuration, without optional accessories.
- Not available
Data certified in EUROVENT

GENERAL TECHNICAL DATA

Data Book
DB_ME_MECH-IF-G05 0411 - 0902_012024_EN
R513A

[SI System]

MECH-IF-G05-NR		0411	0802	0902	
Power supply		V/ph/Hz	400/3/50	400/3/50	400/3/50
PERFORMANCE					
COOLING ONLY (GROSS VALUE)					
Cooling capacity	(1)	kW	411,0	807,0	913,0
Total power input	(1)	kW	134,5	251,0	291,1
EER	(1)	kW/kW	3,056	3,215	3,136
COOLING ONLY (EN14511 VALUE)					
Cooling capacity	(1)(4)	kW	410,6	806,3	912,4
EER	(1)(4)	kW/kW	3,010	3,170	3,100
COOLING WITH PARTIAL RECOVERY					
Cooling capacity	(5)	kW	426,5	837,2	947,2
Total power input	(5)	kW	130,1	242,8	281,6
Desuperheater heating capacity	(5)	kW	112,6	209,1	242,4
EXCHANGERS					
HEAT EXCHANGER USER SIDE IN COOLING					
Water flow	(1)	l/s	19,66	38,59	43,66
Pressure drop at the heat exchanger	(1)(4)	kPa	53,3	50,0	40,1
PARTIAL RECOVERY USER SIDE IN REFRIGERATION					
Water flow	(1)	l/s	5,434	10,09	11,70
Pressure drop at the heat exchanger	(1)	kPa	32,1	27,7	37,3
PERFORMANCE					
COOLING ONLY (GROSS VALUE)					
16°C/10°C					
Cooling capacity	(2)	kW	446,0	874,4	990,3
Total power input	(2)	kW	140,4	260,5	304,0
EER	(2)	kW/kW	3,177	3,357	3,258
23°C/15°C					
Cooling capacity	(3)	kW	514,0	1005	1139
Total power input	(3)	kW	149,7	273,9	324,5
EER	(3)	kW/kW	3,434	3,669	3,510
EXCHANGERS					
16°C/10°C					
Water flow	(2)	l/s	17,79	34,87	39,50
Pressure drop at the heat exchanger	(2)	kPa	45,0	42,1	33,8
23°C/15°C					
Water flow	(3)	l/s	15,40	30,10	34,13
Pressure drop at the heat exchanger	(3)	kPa	35,2	32,8	26,4
REFRIGERANT CIRCUIT					
Compressors nr.		N°	1	2	2
Number of capacity steps		N°	0	0	0
No. Circuits		N°	1	2	2
Regulation			STEPLESS	STEPLESS	STEPLESS
Min. capacity step		%	24	13	13
Refrigerant			R513A	R513A	R513A
Theoretical refrigerant charge		kg	89,0	170	199
Oil charge		kg	11,0	22,0	22,0
Rc (ASHRAE)	(6)	kg/kW	0,22	0,21	0,22
FANS					
Quantity		N°	6	12	14
Air flow		m³/s	29,40	58,80	68,60
Total fans power input		kW	8,40	16,80	19,60
NOISE LEVEL					
Total sound Pressure	(7)	dB(A)	61	62	68
Total sound power level in cooling	(8)(9)	dB(A)	93	95	101
SIZE AND WEIGHT					
A	(10)	mm	4150	7900	9150
B	(10)	mm	2260	2260	2260
H	(10)	mm	2500	2500	2500
Operating weight	(10)	kg	4350	8150	8610

Notes:

1 Plant (side) cooling exchanger water (in/out) 12,00°C/7,00°C; Source (side) heat exchanger air (in) 35,0°C.
2 Plant (side) cooling exchanger water (in/out) 16,00°C/10,00°C; Source (side) heat exchanger air (in) 35,0°C.
3 Plant (side) cooling exchanger water (in/out) 23,00°C/15,00°C; Source (side) heat exchanger air (in) 35,0°C.
4 Values in compliance with EN14511
5 Plant (side) cooling exchanger water (in/out) 12,00°C/7,00°C; Source (side) heat exchanger air (in) 35,0°C; Plant (side) heat exchanger recovery water (in/out) 40,00°C/45,00°C.

6 Rated in accordance with AHRI Standard 550/590
7 Average sound pressure level at 10m distance, unit in a free field on a reflective surface; non-binding value calculated from the sound power level.
8 Sound power on the basis of measurements taken in compliance with ISO 9614.
9 Sound power level in cooling, outdoors.
10 Unit in standard configuration, without optional accessories.
- Not available
Data certified in EUROVENT

GENERAL TECHNICAL DATA

Data Book
DB_ME_MECH-IF-G05 0411 - 0902_012024_EN
R513A

[SI System]

MECH-IF-G05-SL		0411	0802	0902	
Power supply		V/ph/Hz	400/3/50	400/3/50	400/3/50
PERFORMANCE					
COOLING ONLY (GROSS VALUE)					
Cooling capacity	(1)	kW	407,1	799,6	903,7
Total power input	(1)	kW	135,6	252,8	293,1
EER	(1)	kW/kW	3,002	3,163	3,083
COOLING ONLY (EN14511 VALUE)					
Cooling capacity	(1)(4)	kW	406,6	799,0	903,1
EER	(1)(4)	kW/kW	2,960	3,120	3,050
COOLING WITH PARTIAL RECOVERY					
Cooling capacity	(5)	kW	422,4	829,6	937,6
Total power input	(5)	kW	131,1	244,5	283,4
Desuperheater heating capacity	(5)	kW	115,2	213,9	247,9
EXCHANGERS					
HEAT EXCHANGER USER SIDE IN COOLING					
Water flow	(1)	l/s	19,47	38,24	43,22
Pressure drop at the heat exchanger	(1)(4)	kPa	52,5	49,3	39,4
PARTIAL RECOVERY USER SIDE IN REFRIGERATION					
Water flow	(1)	l/s	5,559	10,33	11,97
Pressure drop at the heat exchanger	(1)	kPa	33,6	29,0	39,0
PERFORMANCE					
COOLING ONLY (GROSS VALUE)					
16°C/10°C					
Cooling capacity	(2)	kW	442,1	866,5	980,4
Total power input	(2)	kW	142,0	263,1	307,1
EER	(2)	kW/kW	3,113	3,293	3,192
23°C/15°C					
Cooling capacity	(3)	kW	514,0	1005	1139
Total power input	(3)	kW	149,7	273,9	324,5
EER	(3)	kW/kW	3,434	3,669	3,510
EXCHANGERS					
16°C/10°C					
Water flow	(2)	l/s	17,63	34,56	39,10
Pressure drop at the heat exchanger	(2)	kPa	44,3	41,5	33,2
23°C/15°C					
Water flow	(3)	l/s	15,40	30,10	34,13
Pressure drop at the heat exchanger	(3)	kPa	35,2	32,8	26,4
REFRIGERANT CIRCUIT					
Compressors nr.		N°	1	2	2
Number of capacity steps		N°	0	0	0
No. Circuits		N°	1	2	2
Regulation			STEPLESS	STEPLESS	STEPLESS
Min. capacity step		%	24	13	13
Refrigerant			R513A	R513A	R513A
Theoretical refrigerant charge		kg	89,0	170	199
Oil charge		kg	11,0	22,0	22,0
Rc (ASHRAE)	(6)	kg/kW	0,22	0,21	0,22
FANS					
Quantity		N°	6	12	14
Air flow		m³/s	27,78	55,56	64,82
Total fans power input		kW	6,60	13,20	15,40
NOISE LEVEL					
Total sound Pressure	(7)	dB(A)	57	58	64
Total sound power level in cooling	(8)(9)	dB(A)	89	91	97
SIZE AND WEIGHT					
A	(10)	mm	4150	7900	9150
B	(10)	mm	2260	2260	2260
H	(10)	mm	2500	2500	2500
Operating weight	(10)	kg	4410	8240	8700

Notes:

1 Plant (side) cooling exchanger water (in/out) 12,00°C/7,00°C; Source (side) heat exchanger air (in) 35,0°C.
2 Plant (side) cooling exchanger water (in/out) 16,00°C/10,00°C; Source (side) heat exchanger air (in) 35,0°C.
3 Plant (side) cooling exchanger water (in/out) 23,00°C/15,00°C; Source (side) heat exchanger air (in) 35,0°C.
4 Values in compliance with EN14511
5 Plant (side) cooling exchanger water (in/out) 12,00°C/7,00°C; Source (side) heat exchanger air (in) 35,0°C; Plant (side) heat exchanger recovery water (in/out) 40,00°C/45,00°C.

6 Rated in accordance with AHRI Standard 550/590
7 Average sound pressure level at 10m distance, unit in a free field on a reflective surface; non-binding value calculated from the sound power level.
8 Sound power on the basis of measurements taken in compliance with ISO 9614.
9 Sound power level in cooling, outdoors.
10 Unit in standard configuration, without optional accessories.
- Not available
Data certified in EUROVENT

7 TECHNICAL DATA SEASONAL EFFICIENCY IN COOLING (EN14825 VALUE)

Data Book
DB_ME_MECH-iF-G05 0411 - 0902_012024_EN
R513A

[SI System]

ENERGY EFFICIENCY

SEASONAL EFFICIENCY IN COOLING (Reg. EU 2016/2281)

Ambient refrigeration

MECH-iF-G05			0411	0802	0902						
Prated,c	(1)	kW	413,9	814,1	920,4						
SEER	(1) (2)	-	5,34	5,62	5,73						
Performance ηs	(1) (3)	%	210,0	222,0	226,0						

MECH-iF-G05-NR			0411	0802	0902						
Prated,c	(1)	kW	410,6	806,3	912,4						
SEER	(1) (2)	-	5,33	5,61	5,73						
Performance ηs	(1) (3)	%	210,0	222,0	226,0						

MECH-iF-G05-SL			0411	0802	0902						
Prated,c	(1)	kW	406,6	799,0	903,1						
SEER	(1) (2)	-	5,32	5,62	5,73						
Performance ηs	(1) (3)	%	210,0	222,0	226,0						

Notes:

(1) Parameter calculated according to [REGULATION (EU) N. 2016/2281]

(2) Seasonal energy efficiency ratio

(3) Seasonal space cooling energy efficiency

The units highlighted in this publication contain R513A [GWP₁₀₀ 572] fluorinated greenhouse gases.

Data certified in EUROVENT

[SI System]

ENERGY EFFICIENCY

SEASONAL EFFICIENCY IN COOLING (Reg. EU 2016/2281)

High temperature process cooling

MECH-iF-G05			0411	0802	0902						
Prated,c	(1)	kW	413,90	814,07	920,40						
SEPR HT	(1) (3)	-	6,36	6,72	6,85						

MECH-iF-G05-NR			0411	0802	0902						
Prated,c	(1)	kW	410,56	806,30	912,38						
SEPR HT	(1) (3)	-	6,35	6,70	6,83						

MECH-iF-G05-SL			0411	0802	0902						
Prated,c	(1)	kW	406,60	798,96	903,08						
SEPR HT	(1) (3)	-	6,34	6,70	6,82						

SEASONAL EFFICIENCY IN COOLING (Reg. EU 2015/1095)

Process refrigeration at medium temperature

Notes:

(1) Seasonal energy efficiency of high temperature process cooling [REGULATION (EU) N. 2016/2281]

(2) Seasonal Energy Efficiency of Process Cooling at Medium Temperature [REGULATION (EU) N. 2015/1095]

(3) Seasonal energy efficiency ratio

The units highlighted in this publication contain R513A [GWP₁₀₀ 572] fluorinated greenhouse gases.

Data certified in EUROVENT

8.1 Operating limits - Graphs

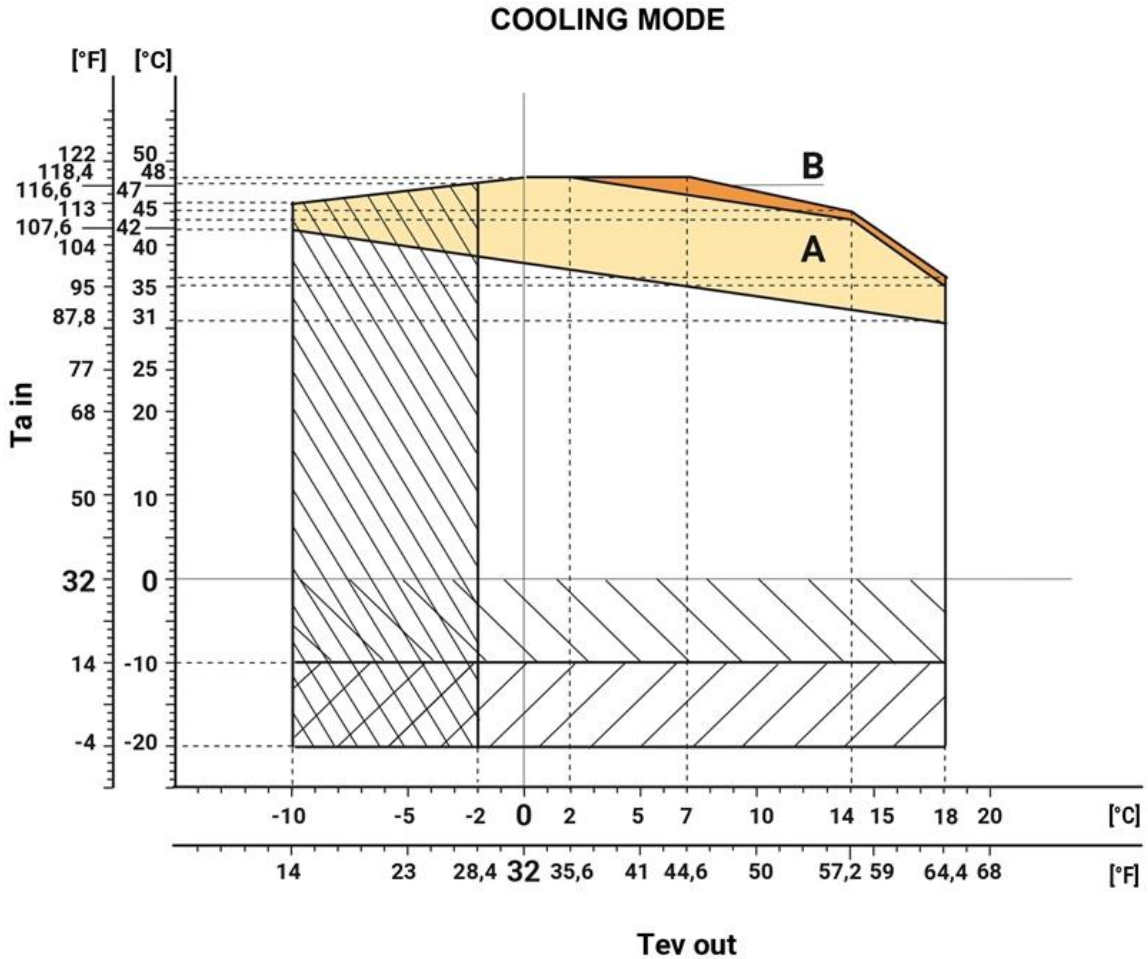

Ta in Outdoor air temperature

Tev out Evaporator leaving water temperature

- Unit at full load.
Unit at full load not super low noise (-SL version)
- Required: Antifreeze heaters on pipes, pumps* (opt. 2432) *if present.
- Required: Antifreeze heaters on pipes, pumps* (opt. 2432) *if present.
Extra insulation on heat exchangers / pipes + pumps* (opt. 2631 / 2633) *if present.
Electric heater on electric board (opt. 3391)
- LT kit for low evaporator leaving water temperature (opt. 1671)
- A** Unit at full load.
Unit at full load not super low noise (-SL version)
- B** Unit at partial load.
Unit at partial load not super low noise (-SL version)

In particular operating conditions the unit can work with forced ventilation, at partial loads or with derating compressors. For any specific information please refer to the ElcaWorld software selection.

For the specific temperature limits of each model please refer to the selection software ElcaWorld.

8 OPERATING LIMITS

Data Book
DB_ME_MECH-iF-G05 0411 - 0902_012024_EN
R513A

8.2 ETHYLENE GLYCOL MIXTURE

Ethylene glycol and water mixture, used as a heat-conveying fluid, cause a variation in unit performance. For correct data, use the factors indicated in the following tabel.

	Freezing point (°C)							
	0	-5	-10	-15	-20	-25	-30	-35
	Ethylene glycol percentage by weight							
	0%	12%	20%	30%	35%	40%	45%	50%
cPf	1	0,985	0,98	0,974	0,97	0,965	0,964	0,96
cQ	1	1,02	1,04	1,075	1,11	1,14	1,17	1,2
cdp	1	1,07	1,11	1,18	1,22	1,24	1,27	1,3

cPf: cooling power correction factor

cQ: flow correction factor

cdp: pressure drop correction factor

For data concerning other kind of anti-freeze solutions (e.g, propylene glycol) please contact our Sale Department.

8.3 FOULING FACTORS

Performances are based on clean condition of tubes (fouling factor = 1). For different fouling values, performance should be adjusted using the correction factors shown in the following table.

SERIES	FOULING FACTORS	EVAPORATOR			CONDENSER/RECOVERY			DESUPERHEATER
	ff (m ² °CW)	F1	FK1	KE [°C]	F2	FK2	KC [°C]	R3
VARIOUS	0	1,000	1,000	0,0	1,000	1,000	0,0	1,000
VARIOUS	1,80 x 10 ⁻⁵	1,000	1,000	0,0	1,000	1,000	0,0	1,000
VARIOUS	4,40 x 10 ⁻⁵	1,000	1,000	0,0	0,990	1,030	1,0	0,990
VARIOUS	8,80 x 10 ⁻⁵	0,960	0,990	0,7	0,980	1,040	1,5	0,980
VARIOUS	13,20 x 10 ⁻⁵	0,944	0,985	1,0	0,964	1,050	2,3	0,964
VARIOUS	17,20 x 10 ⁻⁵	0,930	0,980	1,5	0,950	1,060	3,0	0,950

ff: fouling factors

F1 - F2: potential correction factors

FK1 - FK2: compressor power input correction factors

R3: capacity correction factors

KE: minimum evaporator outlet temperature increase

KC: maximum condenser outlet temperature decrease

9 HYDRAULIC DATA

Data Book
DB_ME_MECH-iF-G05 0411 - 0902_012024_EN
R513A

[SI System]

Water flow and pressure drop

Water flow in the plant (side) exchanger is given by:

$$Q = P / (4,186 \times Dt)$$

Q: water flow (l/s)

Dt: difference between inlet and outlet water temp. (°C)

P: heat exchanger capacity (kW)

Pressure drop is given by:

$$Dp = K \times (3,6 \times Q)^2 / 1000$$

Q: water flow (l/s)

Dp: pressure drop (kPa)

K: unit size ratio

SIZE	Power supply V/ph/Hz	HEAT EXCHANGER USER SIDE					HEAT RECOVERY EX. USER SIDE			
		K	Q min l/s	Q max l/s	C.A.S. l	C.a. min l	K	Q min l/s	Q max l/s	C.A.S. l
MECH-iF-G05 0411	400/3/50	38,2	6,083	27,81	256	2000	-	-	-	-
MECH-iF-G05-LT 0411	400/3/50	39,4	11,17	31,86	159	2000	-	-	-	-
MECH-iF-G05 0802	400/3/50	11,4	14,47	66,19	549	2800	-	-	-	-
MECH-iF-G05-LT 0802	400/3/50	12,8	21,50	57,11	345	2800	-	-	-	-
MECH-iF-G05 0902	400/3/50	7,40	18,14	82,94	537	3200	-	-	-	-
MECH-iF-G05-LT 0902	400/3/50	8,50	26,72	57,11	335	3200	-	-	-	-
MECH-iF-G05-D 0411	400/3/50	38,2	6,083	27,81	256	2000	84,0	0,003	6,583	4,50
MECH-iF-G05-D-LT 0411	400/3/50	39,4	11,17	31,86	159	2000	84,0	0,003	5,583	4,50
MECH-iF-G05-D 0802	400/3/50	11,4	14,47	66,19	549	2800	21,0	0,003	12,22	9,00
MECH-iF-G05-D-LT 0802	400/3/50	12,8	21,50	57,11	345	2800	21,0	0,003	10,06	9,00
MECH-iF-G05-D 0902	400/3/50	7,40	18,14	82,94	537	3200	21,0	0,003	14,17	9,00
MECH-iF-G05-D-LT 0902	400/3/50	8,50	26,72	57,11	335	3200	21,0	0,003	11,89	9,00
MECH-iF-G05-NR 0411	400/3/50	38,2	6,083	27,81	256	2000	-	-	-	-
MECH-iF-G05-NR+LT 0411	400/3/50	39,4	11,17	31,86	159	2000	-	-	-	-
MECH-iF-G05-NR 0802	400/3/50	11,4	14,47	66,19	549	2800	-	-	-	-
MECH-iF-G05-NR+LT 0802	400/3/50	12,8	21,50	57,11	345	2800	-	-	-	-
MECH-iF-G05-NR 0902	400/3/50	7,40	18,14	82,94	537	3200	-	-	-	-
MECH-iF-G05-NR+LT 0902	400/3/50	8,50	26,72	57,11	335	3200	-	-	-	-
MECH-iF-G05-D-NR 0411	400/3/50	38,2	6,083	27,81	256	2000	84,0	0,003	6,583	4,50
MECH-iF-G05-D-NR+LT 0411	400/3/50	39,4	11,17	31,86	159	2000	84,0	0,003	5,583	4,50
MECH-iF-G05-D-NR 0802	400/3/50	11,4	14,47	66,19	549	2800	21,0	0,003	12,22	9,00
MECH-iF-G05-D-NR+LT 0802	400/3/50	12,8	21,50	57,11	345	2800	21,0	0,003	10,06	9,00
MECH-iF-G05-D-NR 0902	400/3/50	7,40	18,14	82,94	537	3200	21,0	0,003	14,17	9,00
MECH-iF-G05-D-NR+LT 0902	400/3/50	8,50	26,72	57,11	335	3200	21,0	0,003	11,89	9,00
MECH-iF-G05-SL 0411	400/3/50	38,2	6,083	27,81	256	2000	-	-	-	-
MECH-iF-G05-SL-LT 0411	400/3/50	39,4	11,17	31,86	159	2000	-	-	-	-
MECH-iF-G05-SL 0802	400/3/50	11,4	14,47	66,19	549	2800	-	-	-	-
MECH-iF-G05-SL-LT 0802	400/3/50	12,8	21,50	57,11	345	2800	-	-	-	-
MECH-iF-G05-SL 0902	400/3/50	7,40	18,14	82,94	537	3200	-	-	-	-
MECH-iF-G05-SL-LT 0902	400/3/50	8,50	26,72	57,11	335	3200	-	-	-	-
MECH-iF-G05-D-SL 0411	400/3/50	38,2	6,083	27,81	256	2000	84,0	0,003	6,583	4,50
MECH-iF-G05-D-SL-LT 0411	400/3/50	39,4	11,17	31,86	159	2000	84,0	0,003	5,583	4,50
MECH-iF-G05-D-SL 0802	400/3/50	11,4	14,47	66,19	549	2800	21,0	0,003	12,22	9,00
MECH-iF-G05-D-SL-LT 0802	400/3/50	12,8	21,50	57,11	345	2800	21,0	0,003	10,06	9,00
MECH-iF-G05-D-SL 0902	400/3/50	7,40	18,14	82,94	537	3200	21,0	0,003	14,17	9,00
MECH-iF-G05-D-SL-LT 0902	400/3/50	8,50	26,72	57,11	335	3200	21,0	0,003	11,89	9,00

Q min: minimum water flow admitted to the heat exchanger

Q max: maximum water flow admitted to the heat exchanger

C.a. min: minimum water content admitted in the plant

C.A.S.: Exchanger water content

10 ELECTRICAL DATA

Data Book
DB_ME_MECH-iF-G05 0411 - 0902_012024_EN
R513A

10.1 ELECTRIC DATA

[SI System]

MECH-iF-G05

SIZE	Power supply V/ph/Hz	Maximum values								
		n	Compressor			Fans (1)		Total (1)(2)		
			F.L.I. [kW]	F.L.A. [A]	L.R.A. [A]	F.L.I. [kW]	F.L.A. [A]	F.L.I. [kW]	F.L.A. [A]	S.A. [A]
0411	400/3/50	1	1x166	1x251	-	6x1.85	6x3	177,1	269	-
0802	400/3/50	2	2x151	2x249	-	12x1.85	12x3	324,1	533	-
0902	400/3/50	2	2x166	2x256	-	14x1.85	14x3	357,2	554	-

F.L.I.: Full load power

F.L.A.: Full load current

L.R.A.: Locked rotor amperes for single compressor

S.A.: Inrush current

(1) Values calculated referring to the version with the maximum number of fans working at the max absorbed current

(1)(2) Safety values to be considered when cabling the unit for power supply and line-protections

Data valid for standard units without any additional option.

Voltage tolerance: 10%

Maximum voltage unbalance: 2%

Give the typical operating conditions of units designed for outdoor installation, which can be associated (according to reference document IEC 60721) to the following classes:

- climatic conditions class 4K4H: air temperature range from -20 up to 55°C (*), relative humidity range from 4 up to 100%, with possible precipitations, at air pressure from 70 and 106 kPa and a maximum solar radiation of 1120 W/m²

- special climatic conditions negligible

- biological conditions class 4B1 and 4C2: locations in a generic urban area

- mechanically active substances class 4S2: locations in areas with sand or dust representative of urban areas

- mechanical conditions class 4M1: locations protected from significant vibrations or shocks

The required protection level for safe operation, according to reference document IEC 60529, is IP43XW (protection against access, to the most critical unit's parts, of external devices with diameter larger than 1 mm and rain).

The unit can be considered IP44XW protected, i.e. protected against access of external devices (with diameter larger than 1 mm) and water in general.

(*) for the unit's operating limits, see "selection limits" section

ELECTRICAL DATA

Data Book
DB_ME_MECH-IF-G05 0411 - 0902_012024_EN
R513A

[SI System]

MECH-IF-G05-NR

SIZE	Power supply V/ph/Hz	Maximum values								
		n	Compressor			Fans (1)		Total (1)(2)		
			F.L.I. [kW]	F.L.A. [A]	L.R.A. [A]	F.L.I. [kW]	F.L.A. [A]	F.L.I. [kW]	F.L.A. [A]	S.A. [A]
0411	400/3/50	1	1x166	1x251	-	6x1.85	6x3	177,1	269	-
0802	400/3/50	2	2x151	2x249	-	12x1.85	12x3	324,1	533	-
0902	400/3/50	2	2x166	2x256	-	14x1.85	14x3	357,2	554	-

F.L.I.: Full load power

F.L.A.: Full load current

L.R.A.: Locked rotor amperes for single compressor

S.A.: Inrush current

(1) Values calculated referring to the version with the maximum number of fans working at the max absorbed current

(1)(2) Safety values to be considered when cabling the unit for power supply and line-protections

Data valid for standard units without any additional option.

Voltage tolerance: 10%

Maximum voltage unbalance: 2%

Give the typical operating conditions of units designed for outdoor installation, which can be associated (according to reference document IEC 60721) to the following classes:

- climatic conditions class 4K4H: air temperature range from -20 up to 55°C (*), relative humidity range from 4 up to 100%, with possible precipitations, at air pressure from 70 and 106 kPa and a maximum solar radiation of 1120 W/m²

- special climatic conditions negligible

- biological conditions class 4B1 and 4C2: locations in a generic urban area

- mechanically active substances class 4S2: locations in areas with sand or dust representative of urban areas

- mechanical conditions class 4M1: locations protected from significant vibrations or shocks

The required protection level for safe operation, according to reference document IEC 60529, is IP43XW (protection against access, to the most critical unit's parts, of external devices with diameter larger than 1 mm and rain).

The unit can be considered IP44XW protected, i.e. protected against access of external devices (with diameter larger than 1 mm) and water in general.

(*) for the unit's operating limits, see "selection limits" section

ELECTRICAL DATA

Data Book
DB_ME_MECH-IF-G05 0411 - 0902_012024_EN
R513A

[SI System]

MECH-IF-G05-SL

SIZE	Power supply V/ph/Hz	Maximum values								
		n	Compressor			Fans (1)		Total (1)(2)		
			F.L.I. [kW]	F.L.A. [A]	L.R.A. [A]	F.L.I. [kW]	F.L.A. [A]	F.L.I. [kW]	F.L.A. [A]	S.A. [A]
0411	400/3/50	1	1x166	1x251	-	6x1.85	6x3	177,1	269	-
0802	400/3/50	2	2x151	2x249	-	12x1.85	12x3	324,1	533	-
0902	400/3/50	2	2x166	2x256	-	14x1.85	14x3	357,2	554	-

F.L.I.: Full load power

F.L.A.: Full load current

L.R.A.: Locked rotor amperes for single compressor

S.A.: Inrush current

(1) Values calculated referring to the version with the maximum number of fans working at the max absorbed current

(1)(2) Safety values to be considered when cabling the unit for power supply and line-protections

Data valid for standard units without any additional option.

Voltage tolerance: 10%

Maximum voltage unbalance: 2%

Give the typical operating conditions of units designed for outdoor installation, which can be associated (according to reference document IEC 60721) to the following classes:

- climatic conditions class 4K4H: air temperature range from -20 up to 55°C (*), relative humidity range from 4 up to 100%, with possible precipitations, at air pressure from 70 and 106 kPa and a maximum solar radiation of 1120 W/m²
- special climatic conditions negligible
- biological conditions class 4B1 and 4C2: locations in a generic urban area
- mechanically active substances class 4S2: locations in areas with sand or dust representative of urban areas
- mechanical conditions class 4M1: locations protected from significant vibrations or shocks

The required protection level for safe operation, according to reference document IEC 60529, is IP43XW (protection against access, to the most critical unit's parts, of external devices with diameter larger than 1 mm and rain).

The unit can be considered IP44XW protected, i.e. protected against access of external devices (with diameter larger than 1 mm) and water in general.

(*) for the unit's operating limits, see "selection limits" section

10 ELECTRIC DATA

Data Book
DB_ME_MECH-iF-G05 0411 - 0902_012024_EN
R513A

10.2 Dimensions of the electrical connections to the main switch**Maximum cables/bars section connected to main switch and short time current**

MECH-iF-G05		LOAD BREAK SWITCH		ATS		Load break switch technical data. Minimum and maximum cable section.	ATS technical data. Minimum and maximum cable section.	ICW (0,3s) Short time current [kA]	ICW (0,3s) Short time current [kA], Opzione 3412	Zs - Maximum permissible plant impedance [Ω]
Version	Size	Model	Rated current [A]	Model	Rated current [A]					
-	0411	SIRCO B5 26003041	400	OXB400E3 X2QB	400	https://www.socomec.com/files/live/sites/systemsite/files/SCP/pdf_catalogue/GB/cat_sircosircoac_en.pdf	TruONE ATS - Main catalog (abb.com)	35	20	0,31
SL										
-	0802	SIRCO B6 26CL3081	800	OXB800E3 X2QB	800					
SL										
-	0902									
SL										

11 FULL LOAD SOUND LEVEL

Data Book
DB_ME_MECH-iF-G05 0411 - 0902_012024_EN
R513A

MECH-iF-G05

SOUND POWER LEVEL IN COOLING									
SIZE	Octave band [Hz]								Total sound level dB(A)
	63	125	250	500	1000	2000	4000	8000	
	Sound power level dB								
0411	98	94	92	91	92	89	83	78	96
0802	101	97	95	94	94	89	83	80	98
0902	102	97	95	95	99	97	93	84	103

Working conditions

Plant (side) cooling exchanger water (in/out) 12,00°C/7,00°C; Source (side) heat exchanger air (in) 35,0°C.

Sound power on the basis of measurements taken in compliance with ISO 9614.

Such certification refers specifically to the sound Power Level in dB(A). This is therefore the only acoustic data to be considered as binding.

Sound power level in cooling, outdoors.

MECH-iF-G05

SOUND PRESSURE LEVEL									
SIZE	Octave band [Hz]								Total sound level dB(A)
	63	125	250	500	1000	2000	4000	8000	
	Sound pressure level dB								
0411	66	62	60	59	60	57	51	46	64
0802	68	64	62	61	61	56	50	47	65
0902	69	64	62	62	66	64	60	51	70

Working conditions

Plant (side) cooling exchanger water (in/out) 12,00°C/7,00°C; Source (side) heat exchanger air (in) 35,0°C.

Average sound pressure level at 10m distance, unit in a free field on a reflective surface; non-binding value calculated from the sound power level.

FULL LOAD SOUND LEVEL

Data Book
DB_ME_MECH-iF-G05 0411 - 0902_012024_EN
R513A

MECH-iF-G05-NR

SOUND POWER LEVEL IN COOLING									
SIZE	Octave band [Hz]								Total sound level dB(A)
	63	125	250	500	1000	2000	4000	8000	
	Sound power level dB								
0411	95	91	89	88	89	87	82	76	93
0802	98	94	92	92	91	87	81	78	95
0902	99	94	92	93	97	96	92	83	101

Working conditions

Plant (side) cooling exchanger water (in/out) 12,00°C/7,00°C; Source (side) heat exchanger air (in) 35,0°C.

Sound power on the basis of measurements taken in compliance with ISO 9614.

Such certification refers specifically to the sound Power Level in dB(A). This is therefore the only acoustic data to be considered as binding.

Sound power level in cooling, outdoors.

MECH-iF-G05-NR

SOUND PRESSURE LEVEL									
SIZE	Octave band [Hz]								Total sound level dB(A)
	63	125	250	500	1000	2000	4000	8000	
	Sound pressure level dB								
0411	63	59	57	56	57	55	50	44	61
0802	65	61	59	59	58	54	48	45	62
0902	66	61	59	60	64	63	59	50	68

Working conditions

Plant (side) cooling exchanger water (in/out) 12,00°C/7,00°C; Source (side) heat exchanger air (in) 35,0°C.

Average sound pressure level at 10m distance, unit in a free field on a reflective surface; non-binding value calculated from the sound power level.

FULL LOAD SOUND LEVEL

Data Book
DB_ME_MECH-iF-G05 0411 - 0902_012024_EN
R513A

MECH-iF-G05-SL

SOUND POWER LEVEL IN COOLING									
SIZE	Octave band [Hz]								Total sound level dB(A)
	63	125	250	500	1000	2000	4000	8000	
	Sound power level dB								
0411	89	86	83	83	86	83	75	71	89
0802	95	92	88	87	88	83	77	75	91
0902	96	92	89	88	94	91	82	80	97

Working conditions

Plant (side) cooling exchanger water (in/out) 12,00°C/7,00°C; Source (side) heat exchanger air (in) 35,0°C.

Sound power on the basis of measurements taken in compliance with ISO 9614.

Such certification refers specifically to the sound Power Level in dB(A). This is therefore the only acoustic data to be considered as binding.

Sound power level in cooling, outdoors.

MECH-iF-G05-SL

SOUND PRESSURE LEVEL									
SIZE	Octave band [Hz]								Total sound level dB(A)
	63	125	250	500	1000	2000	4000	8000	
	Sound pressure level dB								
0411	57	54	51	51	54	51	43	39	57
0802	62	59	55	54	55	50	44	42	58
0902	63	59	56	55	61	58	49	47	64

Working conditions

Plant (side) cooling exchanger water (in/out) 12,00°C/7,00°C; Source (side) heat exchanger air (in) 35,0°C.

Average sound pressure level at 10m distance, unit in a free field on a reflective surface; non-binding value calculated from the sound power level.

12 DIMENSIONAL DRAWINGS

ELCA_Engine ver.4.8.2.0

Data Book
DB_ME_MECH-IF-G05 0411 - 0902_012024_EN
R513A

ATTN: UTILIZZARE N° 4 FUNI DI SOLLEVAMENTO DI PARI LUNGHEZZA
ATTN: USE N° 4 LIFTING ROPES WITH EQUAL LENGTH ONLY

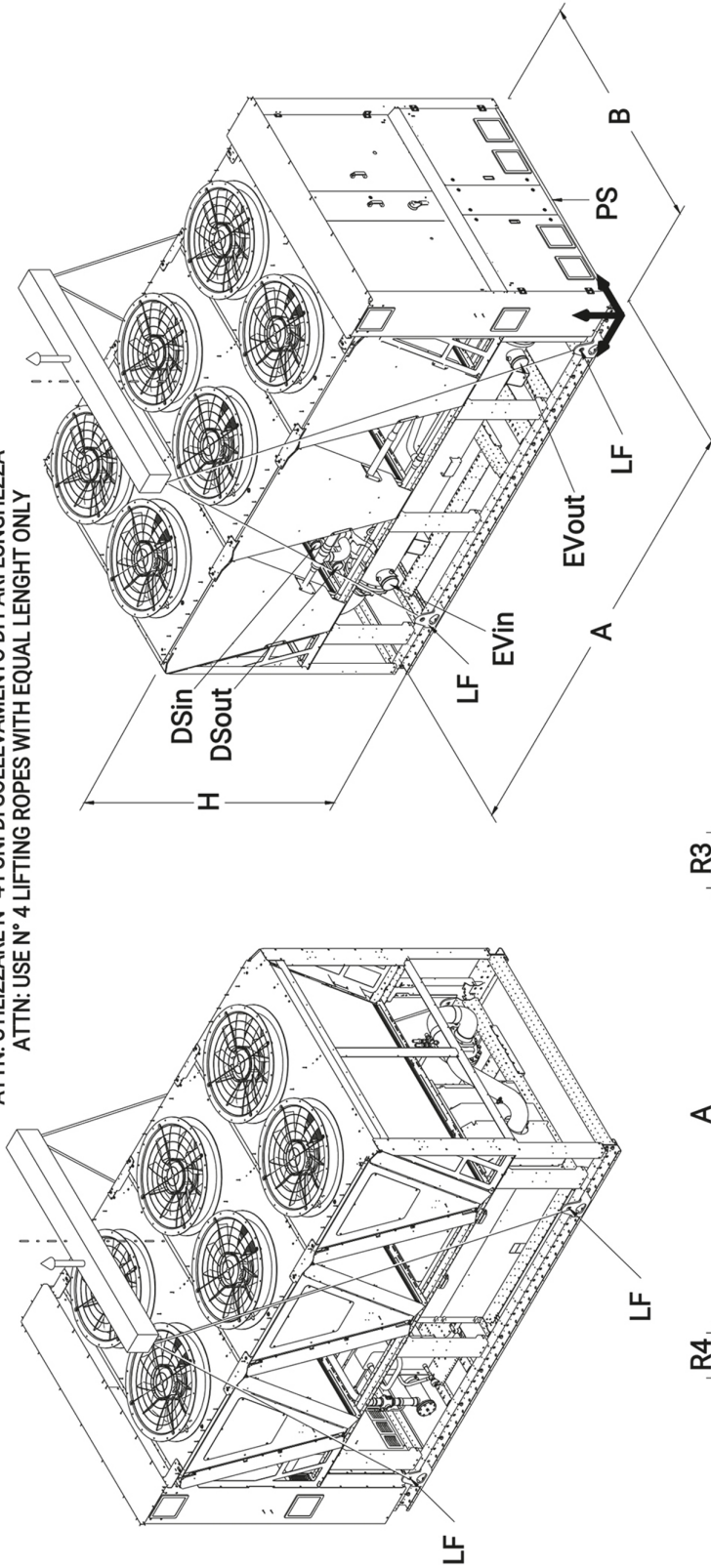

- EVin** Entrata acqua evaporatore
Evaporator water inlet
- EVout** Uscita acqua evaporatore
Evaporator water outlet
- CDin** Entrata acqua desurriscaldatore (solo per versione /D)
Desuperheater water inlet (only for "/D" version)
- CDout** Uscita acqua desurriscaldatore (solo per versione /D)
Desuperheater water outlet (only for "/D" version)
- LF** Punti di sollevamento
Lifting points
- PS** Ingresso linea elettrica
Power inlet

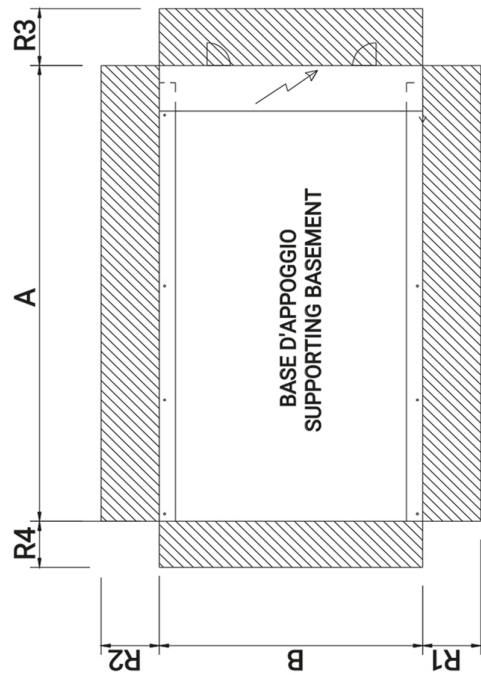

REMARKS: For installation purposes, please refer to the documentation sent after the purchase-contract. This technical data should be considered as indicative. Mitsubishi Electric Hydraulics & IT Cooling Systems S.p.A. may modify them at any moment. Data valid for standard units without any additional option.

DIMENSIONAL DRAWINGS

Data Book
DB_ME_MECH-iF-G05 0411 - 0902_012024_EN
R513A

[SI System]

SIZE	DIMENSIONS AND WEIGHTS				CLEARANCE				HEAT EXCHANGER USER SIDE		HEAT RECOVERY EX. USER SIDE	
	A	B	H	WEIGHT	R1	R2	R3	R4	IN/OUT		IN/OUT	
	[mm]	[mm]	[mm]	[kg]	[mm]	[mm]	[mm]	[mm]	TYPE	Ø	TYPE	Ø
MECH-iF-G05 0411	4150	2260	2500	4350	2000	2500	1500	1500	H	6"	-	-
MECH-iF-G05-LT 0411	4150	2260	2500	4070	2000	2500	1500	1500	H	5"	-	-
MECH-iF-G05-D 0411	4150	2260	2500	4405	2000	2500	1500	1500	H	6"	F1	2 1/2"
MECH-iF-G05-D-LT 0411	4150	2260	2500	4125	2000	2500	1500	1500	H	5"	F1	2 1/2"
MECH-iF-G05-NR 0411	4150	2260	2500	4350	2000	2500	1500	1500	H	6"	-	-
MECH-iF-G05-NR+LT 0411	4150	2260	2500	4070	2000	2500	1500	1500	H	5"	-	-
MECH-iF-G05-D-NR 0411	4150	2260	2500	4405	2000	2500	1500	1500	H	6"	F1	2 1/2"
MECH-iF-G05-D-NR+LT 0411	4150	2260	2500	4125	2000	2500	1500	1500	H	5"	F1	2 1/2"
MECH-iF-G05-SL 0411	4150	2260	2500	4410	2000	2500	1500	1500	H	6"	-	-
MECH-iF-G05-SL-LT 0411	4150	2260	2500	4120	2000	2500	1500	1500	H	5"	-	-
MECH-iF-G05-D-SL 0411	4150	2260	2500	4465	2000	2500	1500	1500	H	6"	F1	2 1/2"
MECH-iF-G05-D-SL-LT 0411	4150	2260	2500	4175	2000	2500	1500	1500	H	5"	F1	2 1/2"

DIMENSIONAL DRAWINGS

ELCA_Engine ver.4.8.2.0

Data Book
DB_ME_MECH-IF-G05 0411 - 0902_012024_EN
R513A

ATTN: UTILIZZARE N° 8 FUNI DI SOLLEVAMENTO DI PARI LUNGHEZZA
ATTN: USE N° 8 LIFTING ROPES WITH EQUAL LENGHT ONLY

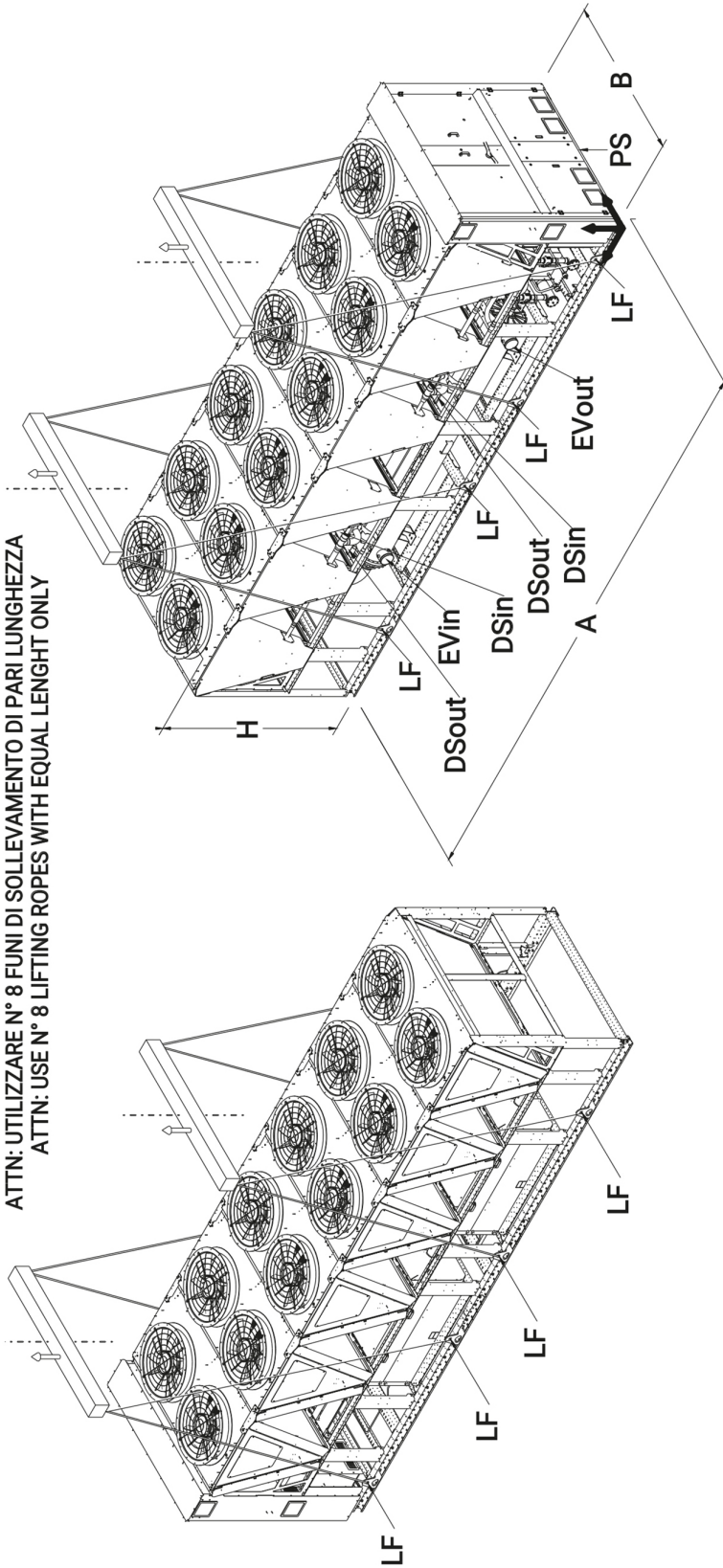

- EVin** Entrata acqua evaporatore
Evaporator water inlet
- EVout** Uscita acqua evaporatore
Evaporator water outlet
- CDin** Entrata acqua desurriscaldatore (solo per versione /D)
Desuperheater water inlet (only for "/D" version)
- CDout** Uscita acqua desurriscaldatore (solo per versione /D)
Desuperheater water outlet (only for "/D" version)
- LF** Punti di sollevamento
Lifting points
- PS** Ingresso linea elettrica
Power inlet

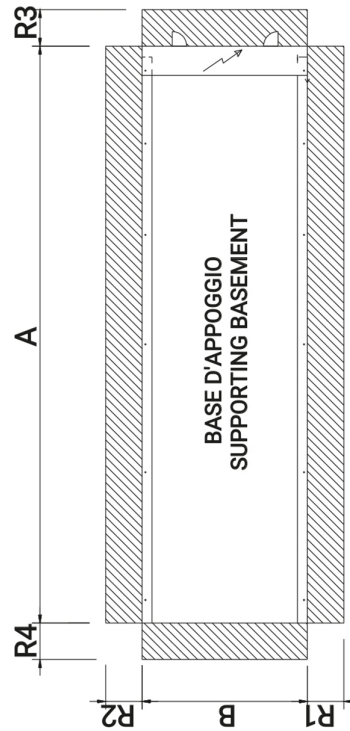

REMARKS: For installation purposes, please refer to the documentation sent after the purchase-contract. This technical data should be considered as indicative. Mitsubishi Electric Hydraulics & IT Cooling Systems S.p.A. may modify them at any moment. Data valid for standard units without any additional option.

DIMENSIONAL DRAWINGS

Data Book
DB_ME_MECH-iF-G05 0411 - 0902_012024_EN
R513A

[SI System]

SIZE	DIMENSIONS AND WEIGHTS				CLEARANCE				HEAT EXCHANGER USER SIDE		HEAT RECOVERY EX. USER SIDE	
	A	B	H	WEIGHT	R1	R2	R3	R4	IN/OUT		IN/OUT	
	[mm]	[mm]	[mm]	[kg]	[mm]	[mm]	[mm]	[mm]	TYPE	Ø	TYPE	Ø
MECH-iF-G05 0802	7900	2260	2500	8150	2000	2500	1500	1500	H	8"	-	-
MECH-iF-G05-LT 0802	7900	2260	2500	7670	2000	2500	1500	1500	H	6"	-	-
MECH-iF-G05-D 0802	7900	2260	2500	8260	2000	2500	1500	1500	H	8"	F1	2 1/2"
MECH-iF-G05-D-LT 0802	7900	2260	2500	7780	2000	2500	1500	1500	H	6"	F1	2 1/2"
MECH-iF-G05-NR 0802	7900	2260	2500	8150	2000	2500	1500	1500	H	8"	-	-
MECH-iF-G05-NR+LT 0802	7900	2260	2500	7670	2000	2500	1500	1500	H	6"	-	-
MECH-iF-G05-D-NR 0802	7900	2260	2500	8260	2000	2500	1500	1500	H	8"	F1	2 1/2"
MECH-iF-G05-D-NR+LT 0802	7900	2260	2500	7780	2000	2500	1500	1500	H	6"	F1	2 1/2"
MECH-iF-G05-SL 0802	7900	2260	2500	8240	2000	2500	1500	1500	H	8"	-	-
MECH-iF-G05-SL-LT 0802	7900	2260	2500	7760	2000	2500	1500	1500	H	6"	-	-
MECH-iF-G05-D-SL 0802	7900	2260	2500	8350	2000	2500	1500	1500	H	8"	F1	2 1/2"
MECH-iF-G05-D-SL-LT 0802	7900	2260	2500	7870	2000	2500	1500	1500	H	6"	F1	2 1/2"

DIMENSIONAL DRAWINGS

ELCA_Engine ver.4.8.2.0

Data Book
DB_ME_MECH-IF-G05 0411 - 0902_012024_EN
R513A

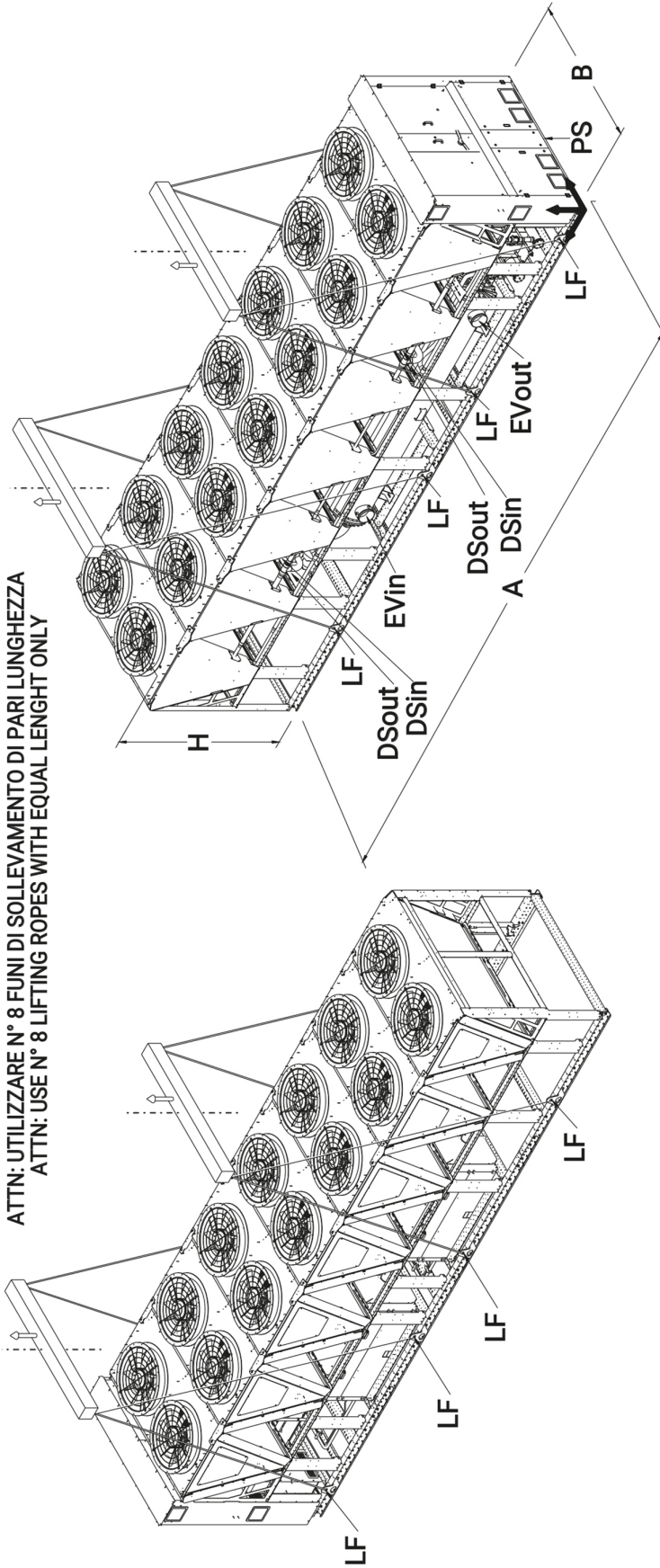

- EVin** Entrata acqua evaporatore
Evaporator water inlet
- EVout** Uscita acqua evaporatore
Evaporator water outlet
- CDin** Entrata acqua desurriscaldatore (solo per versione /D)
Desuperheater water inlet (only for "/D" version)
- CDout** Uscita acqua desurriscaldatore (solo per versione /D)
Desuperheater water outlet (only for "/D" version)
- LF** Punti di sollevamento
Lifting points
- PS** Ingresso linea elettrica
Power inlet

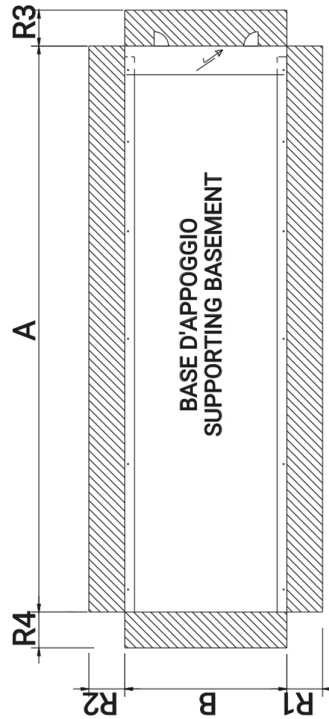

REMARKS: For installation purposes, please refer to the documentation sent after the purchase-contract. This technical data should be considered as indicative. Mitsubishi Electric Hydraulics & IT Cooling Systems S.p.A. may modify them at any moment. Data valid for standard units without any additional option.

DIMENSIONAL DRAWINGS

Data Book
DB_ME_MECH-iF-G05 0411 - 0902_012024_EN
R513A

[SI System]

SIZE	DIMENSIONS AND WEIGHTS				CLEARANCE				HEAT EXCHANGER USER SIDE		HEAT RECOVERY EX. USER SIDE	
	A	B	H	WEIGHT	R1	R2	R3	R4	IN/OUT		IN/OUT	
	[mm]	[mm]	[mm]	[kg]	[mm]	[mm]	[mm]	[mm]	TYPE	Ø	TYPE	Ø
MECH-iF-G05 0902	9150	2260	2500	8610	2000	2500	1500	1500	H	8"	-	-
MECH-iF-G05-LT 0902	9150	2260	2500	8130	2000	2500	1500	1500	H	6"	-	-
MECH-iF-G05-D 0902	9150	2260	2500	8720	2000	2500	1500	1500	H	8"	F1	2 1/2"
MECH-iF-G05-D-LT 0902	9150	2260	2500	8240	2000	2500	1500	1500	H	6"	F1	2 1/2"
MECH-iF-G05-NR 0902	9150	2260	2500	8610	2000	2500	1500	1500	H	8"	-	-
MECH-iF-G05-NR+LT 0902	9150	2260	2500	8130	2000	2500	1500	1500	H	6"	-	-
MECH-iF-G05-D-NR 0902	9150	2260	2500	8720	2000	2500	1500	1500	H	8"	F1	2 1/2"
MECH-iF-G05-D-NR+LT 0902	9150	2260	2500	8240	2000	2500	1500	1500	H	6"	F1	2 1/2"
MECH-iF-G05-SL 0902	9150	2260	2500	8700	2000	2500	1500	1500	H	8"	-	-
MECH-iF-G05-SL-LT 0902	9150	2260	2500	8210	2000	2500	1500	1500	H	6"	-	-
MECH-iF-G05-D-SL 0902	9150	2260	2500	8810	2000	2500	1500	1500	H	8"	F1	2 1/2"
MECH-iF-G05-D-SL-LT 0902	9150	2260	2500	8320	2000	2500	1500	1500	H	6"	F1	2 1/2"

12.2 Legend of pipe connections

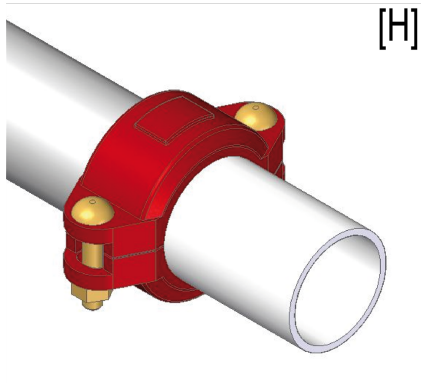

[H]

TYPE = H

[H] - Grooved coupling with weld end counter-pipe user side

NOMINAL PIPE SIZE	PIPE OUTSIDE DIAMETER
ø inches	ø mm
3/4	26,7
1	33,7
1 1/4	42,4
1 1/2	48,3
2	60,3
2 1/2	76,1
3	88,9
3 1/2	101,6

NOMINAL PIPE SIZE	PIPE OUTSIDE DIAMETER
ø inches	ø mm
4	114,3
4 1/2	127,0
5	139,7
6	168,3
8	219,1
10	273,0
12	323,9
14	355,6

UNI ISO 228/13

Pipe threads where pressure-tight joints are not made on the threads - Designation, dimensions and tolerances

Used terminology:

G: Pipe threads where pressure-tight joints are not made on the threads

A: Close tolerance class for external pipe threads where pressure-tight joints are not made on the threads

B: Wider tolerance class for external pipe threads where pressure-tight joints are not made on the threads

Internal threads: G letter followed by thread mark (only tolerance class)

External threads: G letter followed by thread mark and by A letter for A class external threads or by B letter for B class external threads.

UNI EN 10226-1

Pipe threads where pressure-tight joints are made on the threads - Designation, dimensions and tolerances

Used terminology:

Rp: Internal cylindrical threads where pressure-tight joints are made on the threads

Rc: Internal conical threads where pressure-tight joints are made on the threads

R: External conical threads where pressure-tight joints are made on the threads

Internal cylindrical threads: R letter followed by p letter

Internal conical threads: R letter followed by c letter

External conical threads: R letter

NOTE:

Conventional diameter value [in inches] identifies short thread designation, based upon the relative standard.

All relative values are defined by standards.

13.1 Hydronic groups

HYDRONIC MODULE

The units can be fitted with the following types hydronic module:

- Only terminals (modulating)

The hydronic module allows to control the external pumps with the unit controller logic.

- Pumps (fix or variable speed)

The hydronic module includes the pumps and the main water circuit components, thus optimizing hydraulic and electrical installation space, time and costs.

The complete list of the options available is present in the accessory section of the bulletin.

For the hydronic modules with only terminals, the factory-mounted components are:

- Terminals for external pumps control (relays + 0-10V modulating signal)

- Differential pressure switch (on heat exchanger)

- Drain valve (on heat exchanger)

For the hydronic modules with pumps, the factory-mounted components are:

- 2 close-coupled pumps, 2 poles, low or high head, fix or variable speed (inverter)

- Pump suction and discharge valves

- One-way valve (Clapet type for in-line pumps)

- Purge valve

- Drain plug

- Differential pressure switch (on heat exchanger)

- Drain valve (on heat exchanger)

The pumps are controlled in duty/standby, with running hours equalization and changeover on device failure. The electrical panel of the unit is protected with fuses and contactors with thermals cut-out.

Suction, volute and discharge of each pump and all the water pipes are covered with an insulation lining in closed-cell reticulated foam in PE of 15 mm.

The hydronic group is protected by a self-ventilated enclosure. In silenced units (/SL versions and units with Noise Reducer (code 2315)), the enclosure is acoustically insulated by a 30 mm thick lining of polyester fibers (Fiberform).

SIZES	Minimum plant water content for $\Delta T \leq 5 \text{ K}$ [m ³]	Minimum plant water content for $\Delta T > 5 \text{ K}$ [m ³]
411	2.0	2.9
802	2.8	5.7
902	3.2	6.5

END-SUCTION PUMPS

Low or high head pumps

Non-self-priming, single-stage, centrifugal volute end-suction pumps with axial inlet port, radial outlet port and horizontal shaft, designed according to ISO 5199 with dimensions and rated performance according to EN 733 (10 bar). Flanges are PN 16 with dimensions according to EN 1092-2.

The pump is close-coupled to a fan-cooled asynchronous motor. Pump housing and impeller are made of cast iron, while the wear ring is made of bronze. The back pull-out design enables removal of the motor, motor stool and impeller without disturbing the pump housing or pipework. Cast-iron parts have an epoxy-based coating made in a cathodic electro-deposition (CED) process.

The pump housing has both a priming and a drain hole closed by plugs.

The impeller is a closed impeller with double-curved blades with smooth surfaces. The impeller is statically balanced according to ISO 1940-1 class G6.3 and hydraulically balanced to compensate for axial thrust. Wear rings used in pump housing and for impeller are made of bronze.

Motor stool and pump cover are made of cast iron. Coupling guards are fitted to the motor stool. The pump cover is provided with a manual air vent screw for venting of the pump housing and the shaft seal chamber. An O-ring forms the seal between cover and pump housing.

The pump is fitted with an unbalanced rubber bellows seal with torque transmission across the spring and around the bellows. Due to the bellows, the seal does not wear the shaft, and the axial movement is not prevented by deposits on the shaft.

Primary seal:

- Rotating seal ring material: Silicon carbide (SiC)
- Stationary seat material: Silicon carbide (SiC)

This material pairing is used where higher corrosion resistance is required. The high hardness of this material pairing offers good resistance against abrasive particles.

Secondary seal material: EPDM (ethylene-propylene rubber). EPDM has excellent resistance to hot water.

The pumps are fitted with high efficiency motors classified as IE3 in accordance with IEC 60034-30. The fan-cooled motors are totally enclosed, with main dimensions to IEC and DIN standards. Electrical tolerances comply with IEC 60034. Insulation class F (IEC 85). These motors show high efficiency, thus minimizing the energy consumption. The motor can be driven via a variable frequency drive for variable speed operation.



VARIABLE FREQUENCY DRIVE **For pump speed control**

Frequency converters, with IP55 protection rating for rough environment. The drives, one for each pump, are air cooled and installed with a dedicated enclosure.

The fast-response speed control combined with the advanced auto-tuning function ensures safe and accurate operation in any condition.

Optimum control of the excitation current maximizes motor efficiency for additional energy savings.

The drive features built-in EMC filter (EN 61800-3, 1st Environment, Category C2) and DC link choke to significantly reduce electromagnetic noise and current harmonic distortion THDi.

OTHER COMPONENTS

The following components are excluded from the hydronic kit supply, but their use is mandatory for the correct unit and system operation.

These components are available as accessories and supplied loose, it shall be the customer responsibility to install them.

- Unit inlet water filter
- Unit outlet flow-switch

It is also recommended the use of the following components:

- Unit inlet and outlet pressure gauges
- Shut-off valves
- Flexible joints on piping

Possible configurations

PUMP GROUP	Versions	
		SL
EV - 2 PUMPS 2P LH (FIX SPEED)(4711)	X	X
EV - 2 PUMPS 2P HH (FIX SPEED)(4712)	X	X
EV - 2 PUMPS 2P LH (VAR SPEED)(4722)	X	X
EV - 2 PUMPS 2P HH (VAR SPEED)(4723)	X	X

Schema idraulico pompe ORTOGONALI - configurazione STD
 Hydraulic diagram END-SUCTION water PUMPS – STD configuration

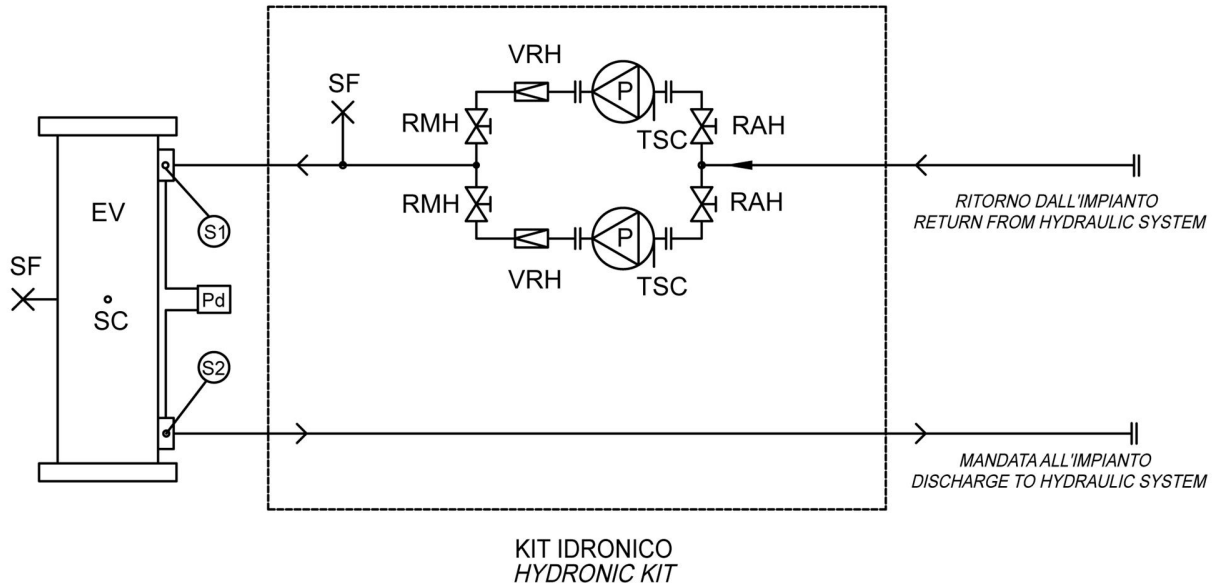

LEGENDA - LEGEND	
<i>COMPONENTI DEL KIT IDRONICO</i> <i>COMPONENTS OF THE HYDRONIC KIT</i>	
EV	Evaporatore (scambiatore a fascio tubiero) Evaporator (tube exchanger)
P	Pompa Water pump
Pd	Pressostato differenziale lato acqua Water Differential pressure switch
RAH	Rubinetto aspirazione Pump suction valve
RMH	Rubinetto mandata Pump discharge valve
SC	Valvola di scarico Drain valve
TSC	Tappo di scarico Drain plug
SF	Valvola di sfiato Purge valve
S1	Sonda ingresso acqua scambiatore Exchanger water inlet probe
S2	Sonda uscita acqua scambiatore Exchanger water outlet probe
VRH	Valvola di non ritorno One way valve

Hydronic kit positioning

	Version	EV - 2 PUMPS 2P LH (FIX SPEED) (4711)				EV - 2 PUMPS 2P HH (FIX SPEED) (4712)				EV - 2 PUMPS 2P LH (VAR SPEED) (4722)				EV - 2 PUMPS 2P HH (VAR SPEED) (4723)			
		extra L [mm]	extra W [mm]	extra H [mm]	extra WGT [kg]	extra L [mm]	extra W [mm]	extra H [mm]	extra WGT [kg]	extra L [mm]	extra W [mm]	extra H [mm]	extra WGT [kg]	extra L [mm]	extra W [mm]	extra H [mm]	extra WGT [kg]
0411	-	1250	/	/	610	1250	/	/	730	1250	/	/	670	1250	/	/	800
	SL	1250	/	/	610	1250	/	/	730	1250	/	/	670	1250	/	/	800
0802	-	1250	/	/	840	1250	/	/	900	1250	/	/	910	1250	/	/	970
	SL	1250	/	/	840	1250	/	/	900	1250	/	/	910	1250	/	/	970
0902	-	/	/	/	770	/	/	/	830	/	/	/	850	/	/	/	910
	SL	/	/	/	770	/	/	/	830	/	/	/	850	/	/	/	910

extra L	Unit's extra length
extra W	Unit's extra operating width (NOT to be considered for transport)
extra H	Unit's extra height
extra WGT	Unit's extra weight (pumps and piping)
EV - 2 PUMPS 2P LH (FIX SPEED)	EV - 2 PUMPS 2P LH (FIX SPEED)
EV - 2 PUMPS 2P HH (FIX SPEED)	EV - 2 PUMPS 2P HH (FIX SPEED)
EV - 2 PUMPS 2P LH (VAR SPEED)	EV - 2 PUMPS 2P LH (VAR SPEED)
EV - 2 PUMPS 2P HH (VAR SPEED)	EV - 2 PUMPS 2P HH (VAR SPEED)
-	Not available

HEAT EXCHANGER USER SIDE - EV - 2 PUMPS 2P HH (FIX SPEED) (4712)

SIZE	Version	CH		PUMP					CH
		Pfgross	Qfgross	Curve	Model	N.	F.L.A.	F.L.I.	HU
		[kW] (1)	[l/s] (1)			Pole	[A]	[kW]	[kPa]
0411	-	414,4	19,82	A1	NB 65-125/144 IE3	2	20	11,00	184
	SL	407,1	19,47						187
0802	-	814,7	38,96	B1	NB 80-160/161 IE3	2	35	18,50	221
	SL	799,6	38,24						225
0902	-	921,1	44,05	B2					211
	SL	903,7	43,22						216

(1) Values refer to nominal conditions
 CH Cooling mode
 Pf Cooling capacity unit (Cooling mode)
 Pt Heating capacity unit (Heating mode)

Q Plant (side) exchanger water flow
 F.L.I. Pump power input
 F.L.A. Pump running current
 HU Pump residual pressure head (Units with hydronic group without mains filter)

HEAT EXCHANGER USER SIDE - EV - 2 PUMPS 2P HH (FIX SPEED) (4712)

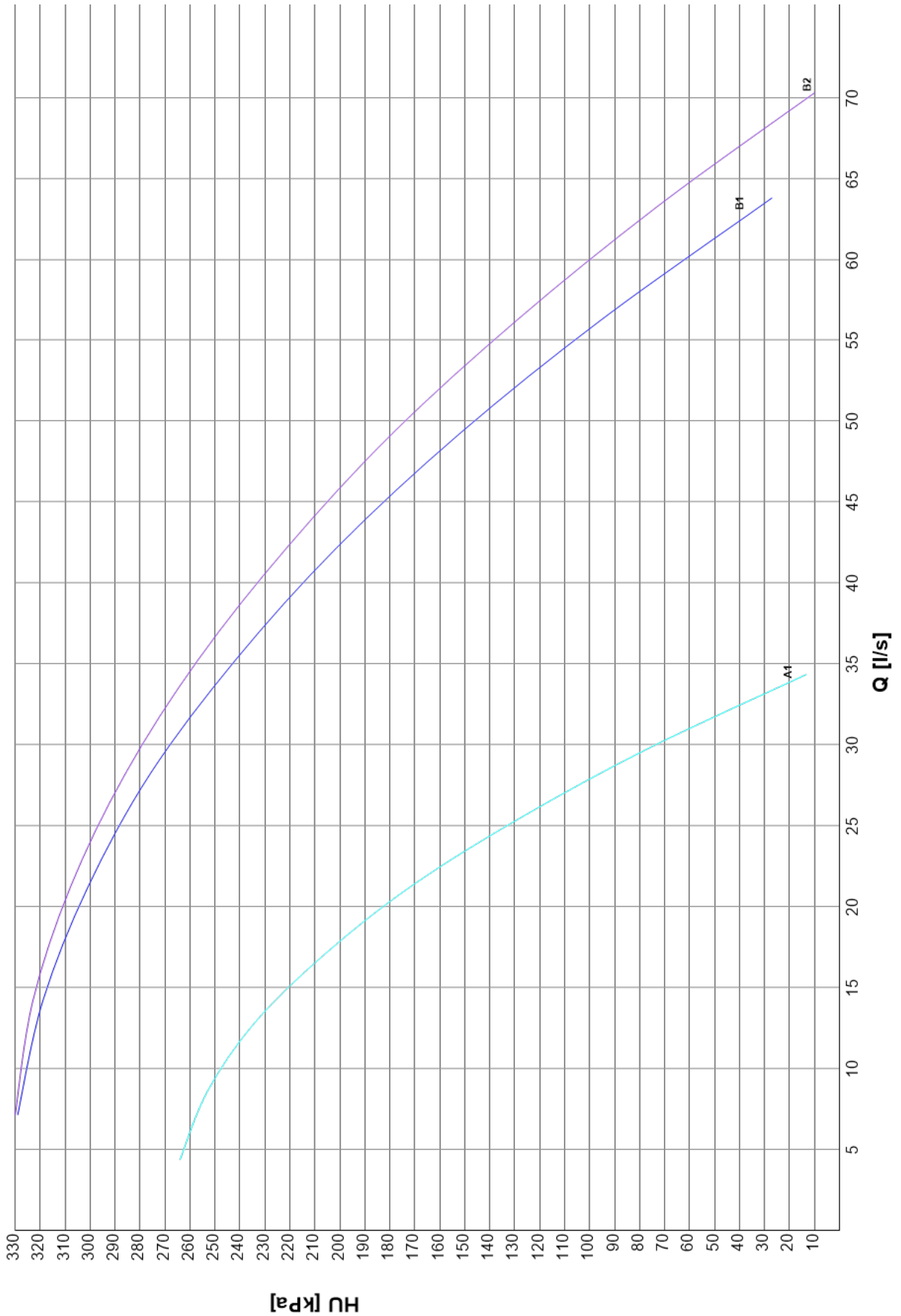

HEAT EXCHANGER USER SIDE - EV - 2 PUMPS 2P HH (VAR SPEED) (4723)

SIZE	Version	CH		PUMP					CH
		Pfgross	Qfgross	Curve	Model	N.	F.L.A.	F.L.I.	HU
		[kW] (1)	[l/s] (1)			Pole	[A]	[kW]	[kPa]
0411	-	414,4	19,82	A1	NB 65-125/144 IE3	2	20	11,00	184
	SL	407,1	19,47						187
0802	-	814,7	38,96	B1	NB 80-160/161 IE3	2	35	18,50	221
	SL	799,6	38,24						225
0902	-	921,1	44,05	B2					211
	SL	903,7	43,22						216

(1) Values refer to nominal conditions
 CH Cooling mode
 Pf Cooling capacity unit (Cooling mode)
 Pt Heating capacity unit (Heating mode)

Q Plant (side) exchanger water flow
 F.L.I. Pump power input
 F.L.A. Pump running current
 HU Pump residual pressure head (Units with hydronic group without mains filter)

HEAT EXCHANGER USER SIDE - EV - 2 PUMPS 2P HH (VAR SPEED) (4723)

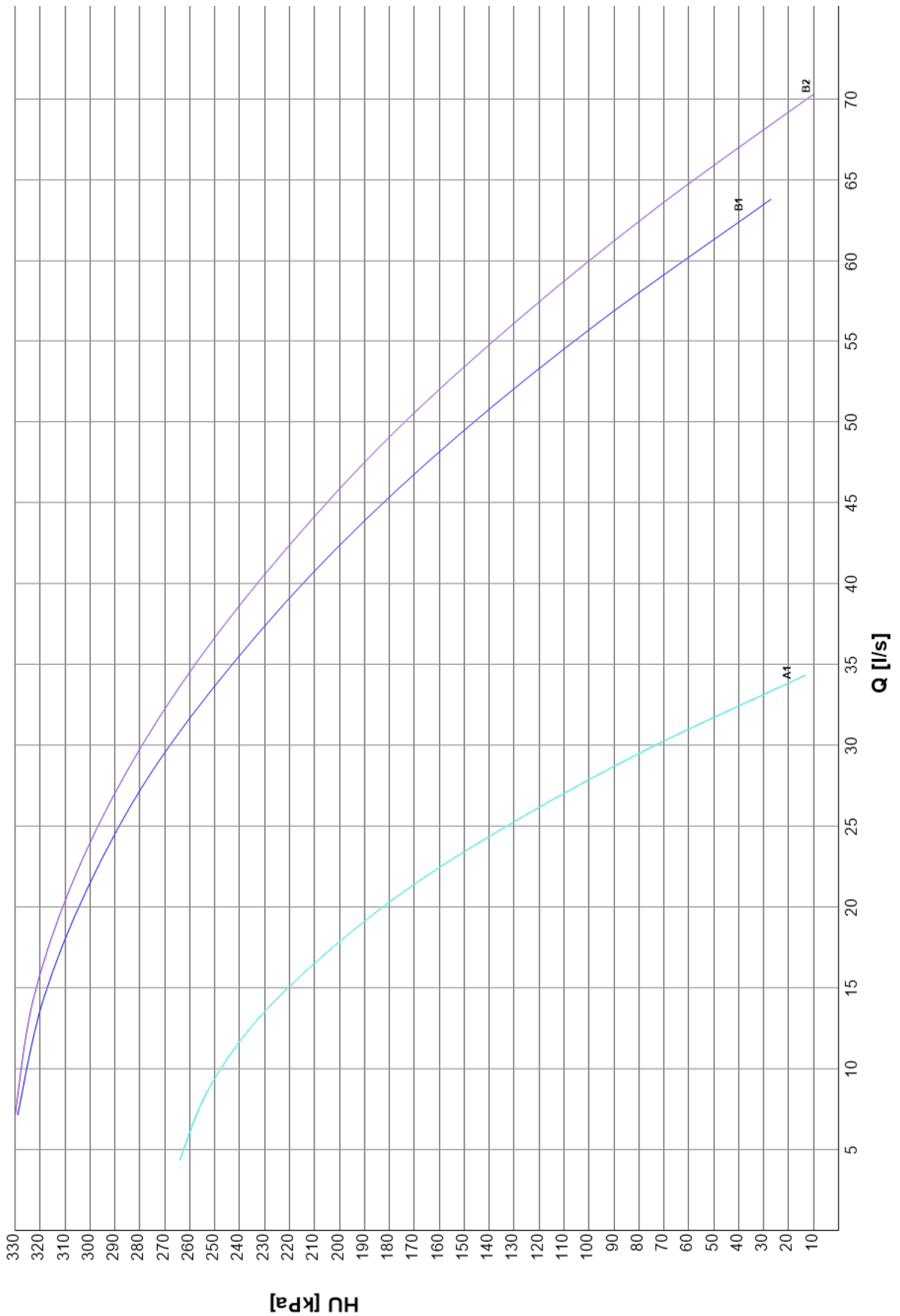

HEAT EXCHANGER USER SIDE - EV - 2 PUMPS 2P LH (FIX SPEED) (4711)

SIZE	Version	CH		PUMP					CH
		Pfgross	Qfgross	Curve	Model	N.	F.L.A.	F.L.I.	HU
		[kW] (1)	[l/s] (1)			Pole	[A]	[kW]	[kPa]
0411	-	414,4	19,82	A1	NB 50-125/135	2	11	5,500	106
	SL	407,1	19,47						111
0802	-	814,7	38,96	B1	NB 80-160/147-127	2	21	11,00	111
	SL	799,6	38,24						116
0902	-	921,1	44,05	B2					98,2
	SL	903,7	43,22						104

(1) Values refer to nominal conditions
 CH Cooling mode
 Pf Cooling capacity unit (Cooling mode)
 Pt Heating capacity unit (Heating mode)

Q Plant (side) exchanger water flow
 F.L.I. Pump power input
 F.L.A. Pump running current
 HU Pump residual pressure head (Units with hydronic group without mains filter)

HEAT EXCHANGER USER SIDE - EV - 2 PUMPS 2P LH (FIX SPEED) (4711)

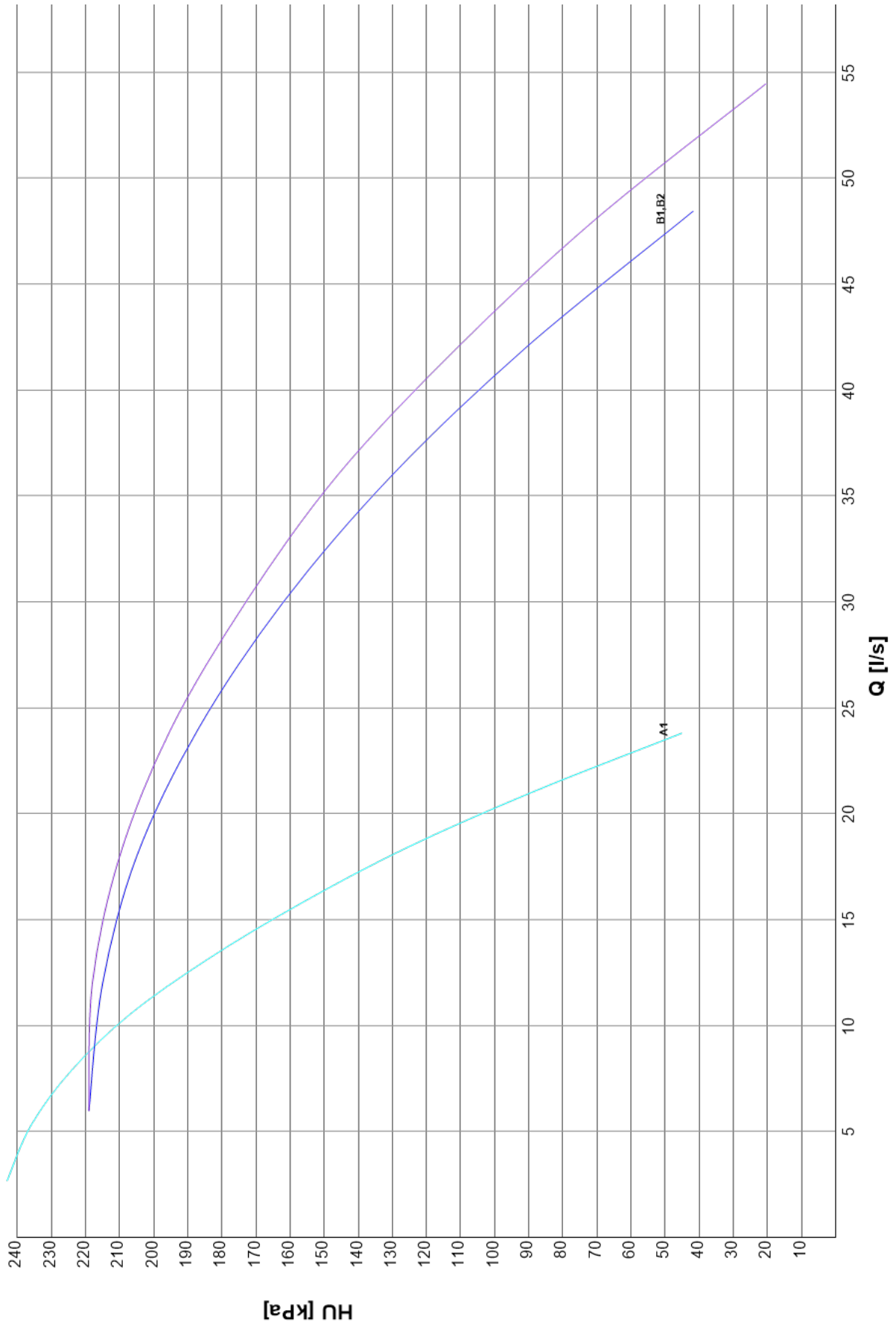

HEAT EXCHANGER USER SIDE - EV - 2 PUMPS 2P LH (VAR SPEED) (4722)

SIZE	Version	CH		PUMP					CH
		Pfgross	Qfgross	Curve	Model	N.	F.L.A.	F.L.I.	HU
		[kW] (1)	[l/s] (1)			Pole	[A]	[kW]	[kPa]
0411	-	414,4	19,82	A1	NB 50-125/135	2	11	5,500	106
	SL	407,1	19,47						111
0802	-	814,7	38,96	B1	NB 80-160/147-127	2	21	11,00	111
	SL	799,6	38,24						116
0902	-	921,1	44,05	B2					98,2
	SL	903,7	43,22						104

(1) Values refer to nominal conditions
 CH Cooling mode
 Pf Cooling capacity unit (Cooling mode)
 Pt Heating capacity unit (Heating mode)

Q Plant (side) exchanger water flow
 F.L.I. Pump power input
 F.L.A. Pump running current
 HU Pump residual pressure head (Units with hydronic group without mains filter)

HEAT EXCHANGER USER SIDE - EV - 2 PUMPS 2P LH (VAR SPEED) (4722) (3520)

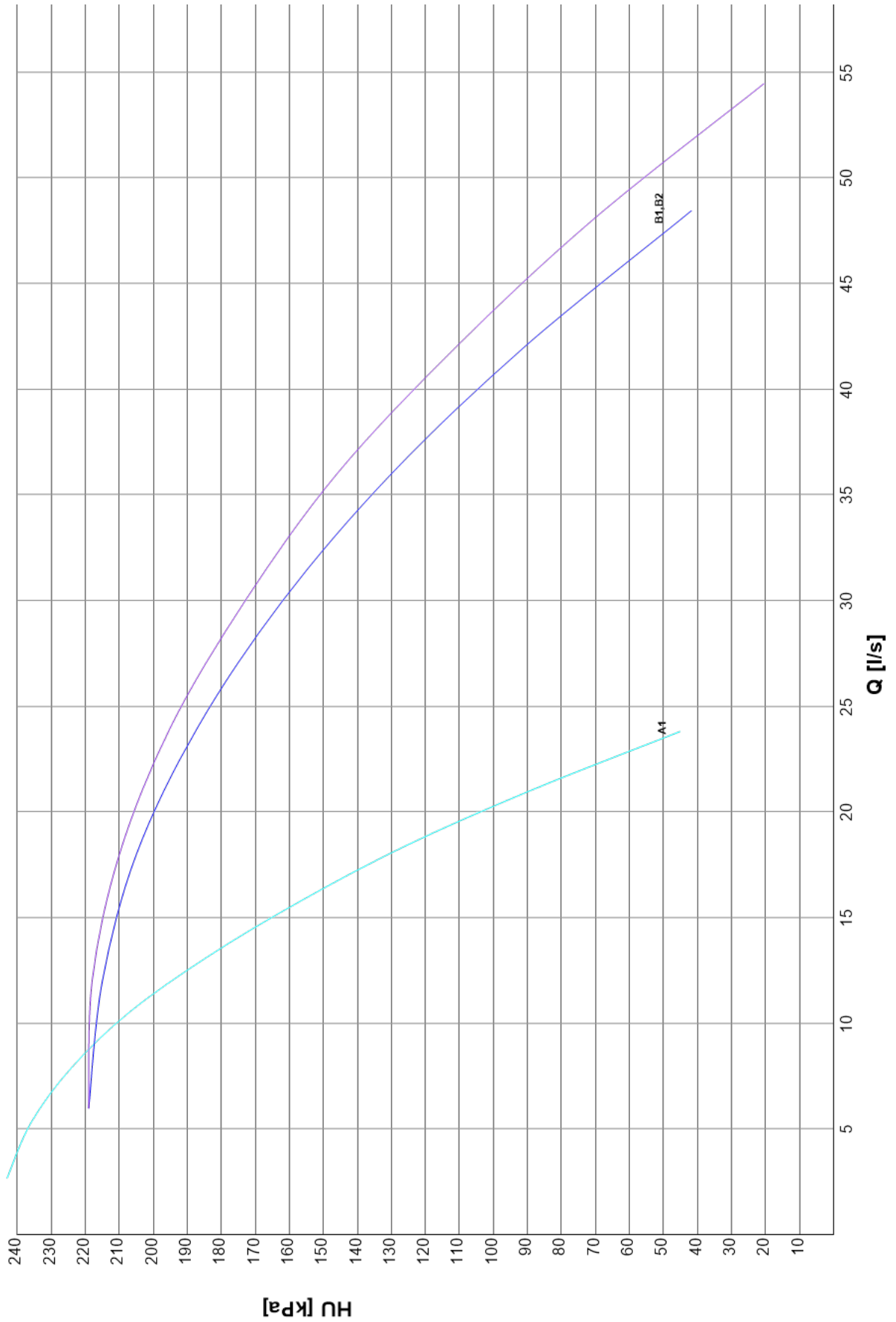

14.1 Variable flow control

Pump energy consumption significantly impacts plant running costs, but it can be considerably reduced thanks to the use of variable speed pumps (inverter driven pumps), capable of adjusting the water flow rate according to the actual plant thermal load.

Mitsubishi Electric Hydronics & Cooling Systems has developed the VPF control series (Variable Primary Flow), that provides different water flow regulation logics specifically devoted to various hydraulic plant solutions: only a primary circuit, primary and secondary circuits, single unit or multi-unit systems controlled with external controller (Manager 3000+, ClimaPRO+) or with 1541, 1542 Multi Manager options.

The VPF systems adjust the pump speeds on the basis of the plant's thermal load and optimize the unit's thermoregulation algorithm for variable flow operation, in a dynamic and simultaneous way. This ensures the highest energy savings, stable operation, and complete reliability.

VPF SYSTEM (delta P control) For plants with only a primary circuit

VPF - Plant and unit requirements

The VPF logic provides the variable flow control for the plant's primary circuit.

- Type of plant: primary circuit only, that feeds hydronic terminals fitted with a 2-way regulating valve
- Hydronic module: modulating regulation devices (0-10V signal) or variable speed pumps
- Unit thermoregulation: control of the leaving water temperature
- Monitored parameter: delta P on relevant users' hydronic terminal

Plant diagram for single unit system

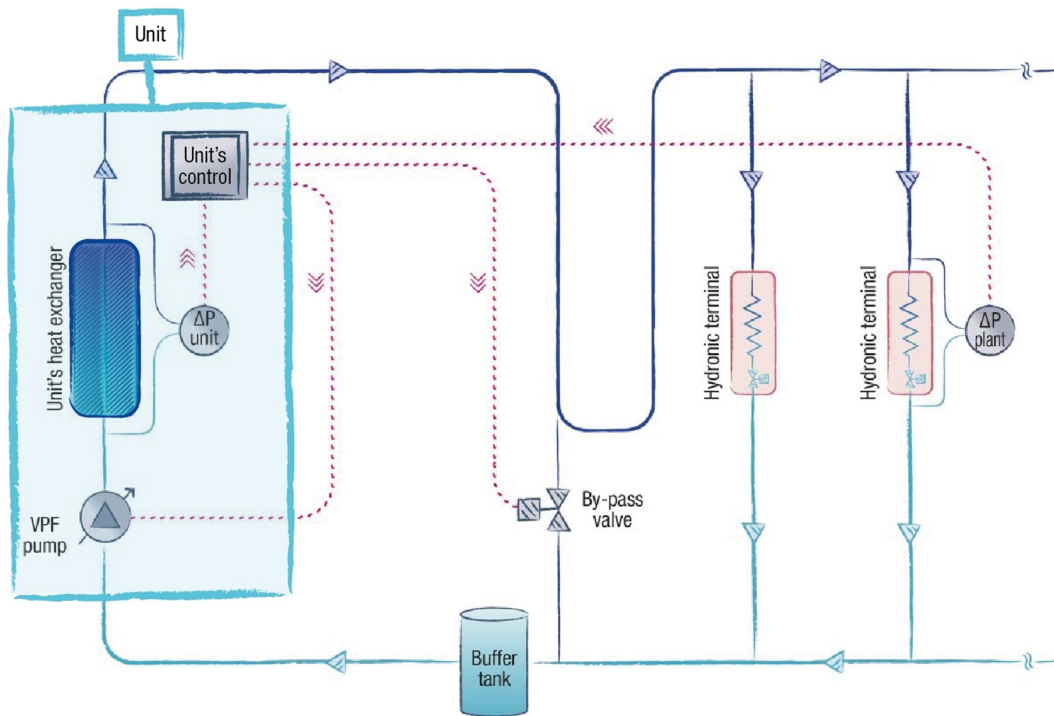

Plant diagram for multi-unit with external control system (Manager3000+ or ClimaPRO+)

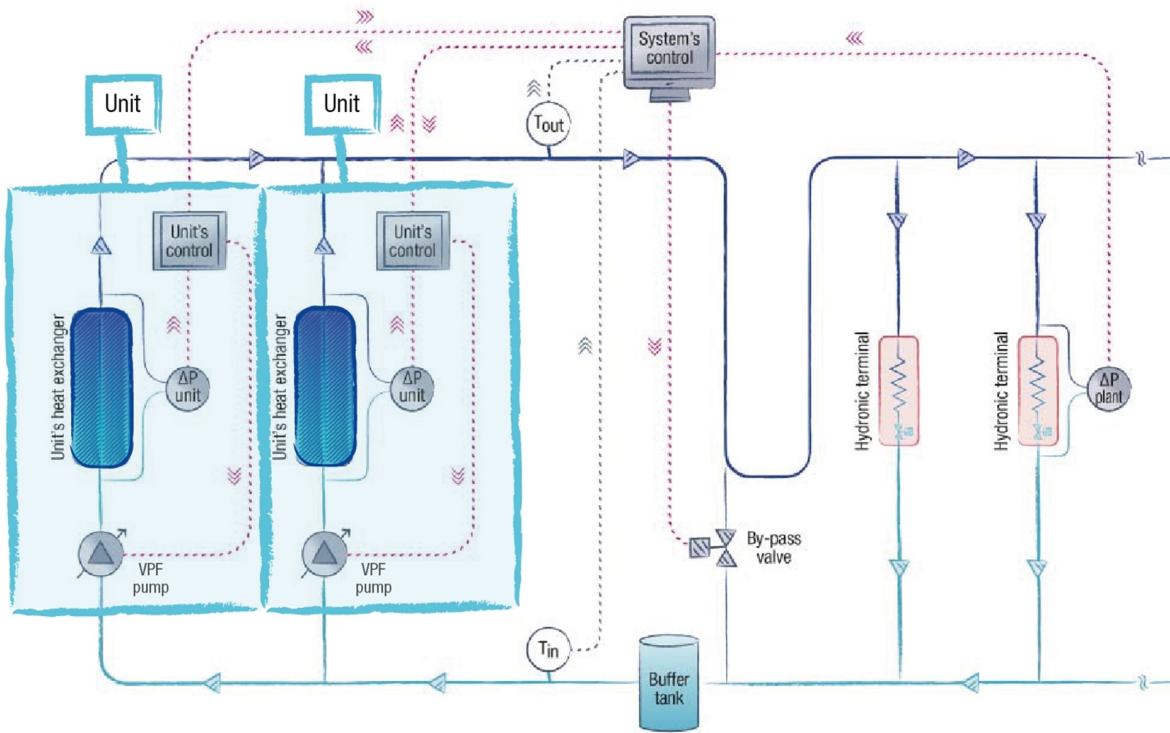

Plant diagram for multi-unit system with Multi Manager

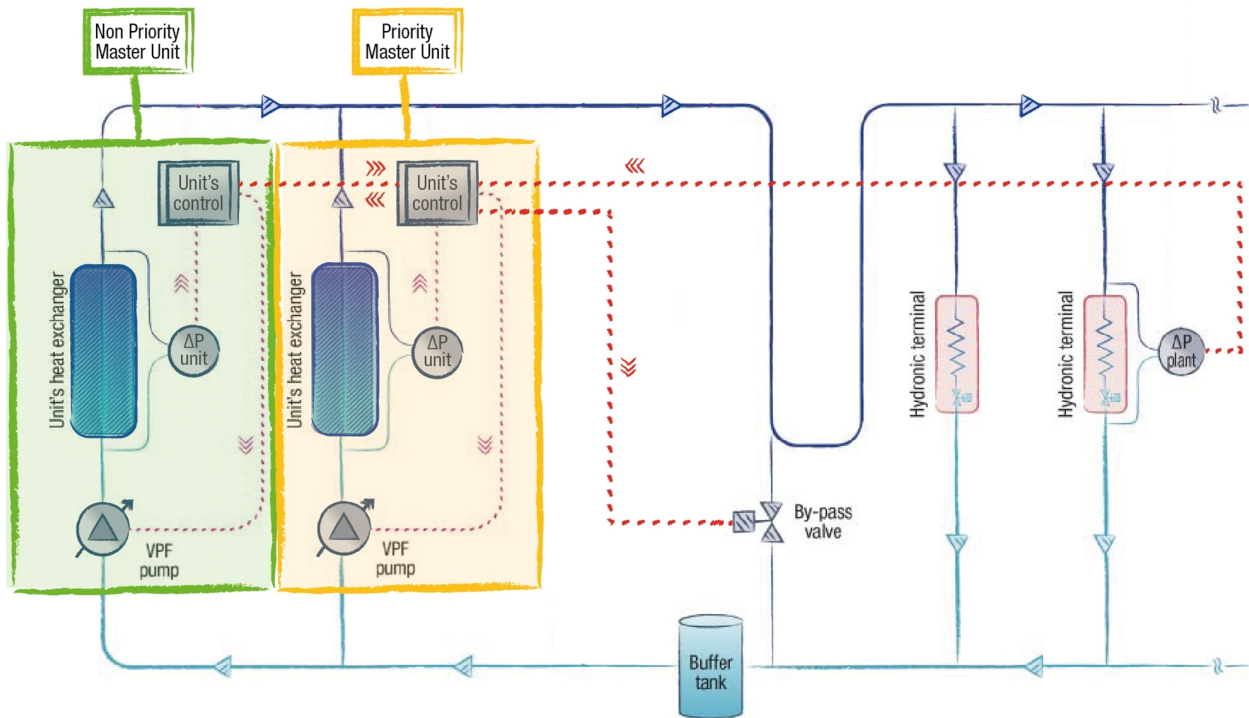

VPF - Operating logic

Water flow regulation

The VPF system monitors the differential pressure on the plant side (ΔP) and adjusts the pump speed in order to keep it within a defined range (ΔP_{min} ΔP_{max}).

- If $\Delta P_{min} \leq \Delta P \leq \Delta P_{max}$

The plant water flow is appropriate to the thermal load, the pump speed is kept constant.

- If $\Delta P > \Delta P_{max}$

The plant water flow exceeds what is necessary to properly cover the thermal load, the pump speed is reduced to save pump energy.

- If $\Delta P < \Delta P_{min}$

The plant water flow is too low to ensure the proper feed to the hydrionic terminals, the pump speed is increased.

With the VPF system, the water flow can be reduced to 50% of the unit nominal water flow, with regards to the selection conditions, provided that the minimum water flow required by the unit's heat exchanger is respected (the control of the heat exchanger's minimum water flow is described below).

The pump speed regulation is performed with little progressive adjustments while continuously monitoring the values of both the delta P on the plant side and the water temperature on the heat exchanger. The absence of abrupt water flow changes prevents fluctuation due to possible conflicts with the unit's thermoregulation function (compressor regulation).

Control of the unit's minimum water flow

Under no circumstances can the primary circuit water flow be reduced below the minimum water flow required by the unit's heat exchanger.

The monitoring of the unit's water flow is performed through a factory installed differential pressure transducer on the unit's heat exchanger.

If the differential pressure on the plant side requests a users' water flow lower than the unit's minimum water flow, the VPF system commands the gradual opening of the hydraulic by-pass valve (safety function). This ensures that the minimum water flow required by the unit's heat exchanger is always provided. As soon as the hydronic terminals request an increase of the water flow ($\Delta P < \Delta P_{min}$), the VPF closes the by-pass valve.

Multi-unit systems

The VPF control logic is also the same for multi-unit systems.

The plant side differential pressure transducer reading and the by-pass valve opening are managed by the multi-unit control system (Manager3000+, ClimaPRO+, Multi Manager Master).

Each unit autonomously adjusts its pump speed on the basis of the information provided by the multi-unit control system.

When the plant load requests the activation of a stand-by unit, the multi-unit control system calculates the starting speed of its pump in order to avoid excessive water flow variation of the running units.

In case of multi-unit system with Multi Manager, at least one unit must be set as Priority Master (opt 1541). To grant redundancy to the system, more than one unit can be configured as Priority Master. All the Priority Masters must be connected to the differential pressure transducer and the by-pass valve. The Multi Manager system only takes into account the signal read and sent by the Master of the moment (a specific filtering device is part of the supply; see the table below, note (8)).

The Non Priority Master cannot be connected to differential pressure transducer and by-pass valve and cannot managed the VPF function. In the event that a Non Priority Master is elected as the Master of the system, the VPF function is suspended.

ATTACHMENTS

Data Book
DB_ME_MECH-IF-G05 0411 - 0902_012024_EN
R513A

VPF - Devices and installation

Device	Accessory name		
	VPF (w/o DP)(SU, MM_PR) ⁽¹⁾	VPF (w DP)(SU, MM_PR) ⁽²⁾	VPF (M3000, CPRO, MM_N-PR) ⁽³⁾
Differential pressure transducer on the unit's heat exchanger and related controller expansion board	Factory installed	Factory installed	Factory installed
Controller expansion board to read the plant side differential pressure transducer (4-20mA signal) and manage the hydraulic by-pass valve opening (0-10V signal)	Factory installed	Factory installed	Factory installed on the multi-unit external control system (Manager3000, ClimaPRO) Not included with option 1542 (Non Priority Master unit) ⁽⁵⁾
Plant side differential pressure transducer	Not included (the supply is the customer's responsibility) ⁽⁴⁾	Factory supplied, installation is the client's responsibility ⁽⁴⁾⁽⁵⁾	Factory supplied with the multi-unit external control system (Manager3000, ClimaPRO); installation is the client's responsibility Not included with option 1542 (Non Priority Master unit) ⁽⁴⁾⁽⁶⁾
Plant side hydraulic by-pass valve	Not included (the supply is the customer's responsibility) ⁽⁷⁾⁽⁸⁾	Not included (the supply is the customer's responsibility) ⁽⁷⁾⁽⁸⁾	Not included (the supply is the customer's responsibility) ⁽⁷⁾

(1) VPF for unit without plant differential pressure transducer included (for single unit plant and Priority Master unit)

(2) VPF for unit with plant differential pressure transducer included (for single unit plant and Priority Master unit)

(3) VPF for multi-unit plant with external controller (Manager3000+, ClimaPRO+) and Non Priority Master unit

(4) It is recommended to install the differential pressure transducer on the most hydraulically critical hydronic terminal, to ensure it has a proper water flow in any load condition.

(5) Technical features of the differential pressure transducer supplied:

Model: Huba Control 692.9 120071C1

Pressure range: 0 ... + 1 bar

Output: 4-20mA

Electrical connection: DIN EN 175301-803-A (IP 65)

Pressure connection adapters: male threaded G 1/8"

(6) It is the customer's responsibility to configure the multi-unit control system (Manager3000+, ClimaPRO+ or Multi Manager) with option VPF.

(7) See attached table for information on the hydraulic by-pass design.

(8) In case of a multi-unit plant with more than one Master Priority unit (opt 1541) please specify it when emailing our sales. An additional device will be added to manage the multiple signals coming from unit's controller to the by-pass valve.

The following table provides the indications for a correct hydraulic by-pass design.

Heat exchanger minimum flow (m ³ /h) ⁽¹⁾	Minimum by-pass diameter	Minimum by-pass valve diameter	Suggested valve model	Kvs	Suggested actuator model
From 19 to 30	DN50 (2")	DN50 (2")	VVG41.50	40	SKB60
Up to 37	DN65 (2" ½)	DN65 (2" ½)	VVF31.65	49	SKB60
Up to 60	DN80 (3")	DN80 (3")	VVF31.80	78	SKB60
Up to 95	DN100 (4")	DN100 (4")	VVF31.90	124	SKC60
Up to 150	DN125 (5")	DN125 (5")	VVF31.91	200	SKC60
Up to 230	DN150 (6")	DN150 (6")	VVF31.92	300	SKC60

((1) In case of a multi-unit system, the unit with the highest minimum water flow should be the reference.

VPF.D SYSTEM (delta T control)

For plants with primary and secondary circuits separated by a hydraulic decoupler.

VPF.D - Plant and unit requirements

The VPF.D logic provides the variable flow control for the plant's primary circuit.

- Type of plant: primary and secondary circuits separated by a hydraulic decoupler
- Hydronic module: modulating regulation devices (0-10V signal) or variable speed pumps
- Unit thermoregulation: control of the leaving water temperature
- Monitored parameter: delta T on primary circuit

Plant diagram for multi-unit with external control system (Manager3000+ or ClimaPRO+)

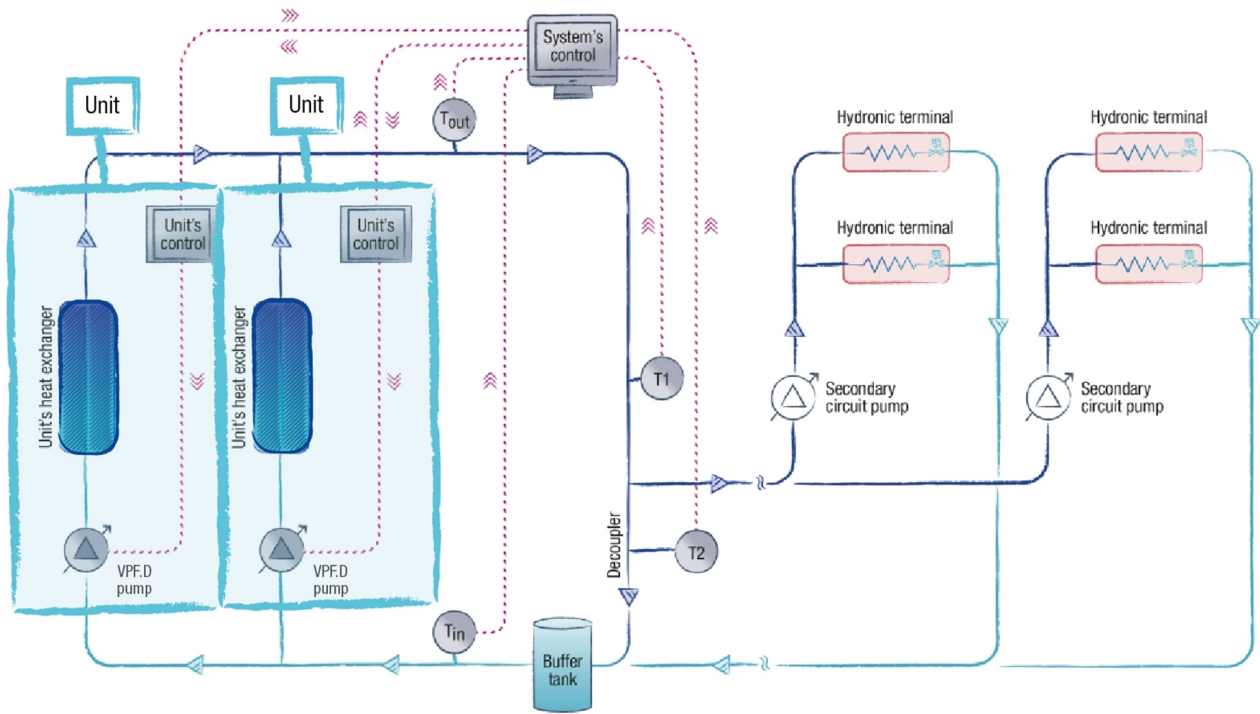

Plant diagram for single unit system

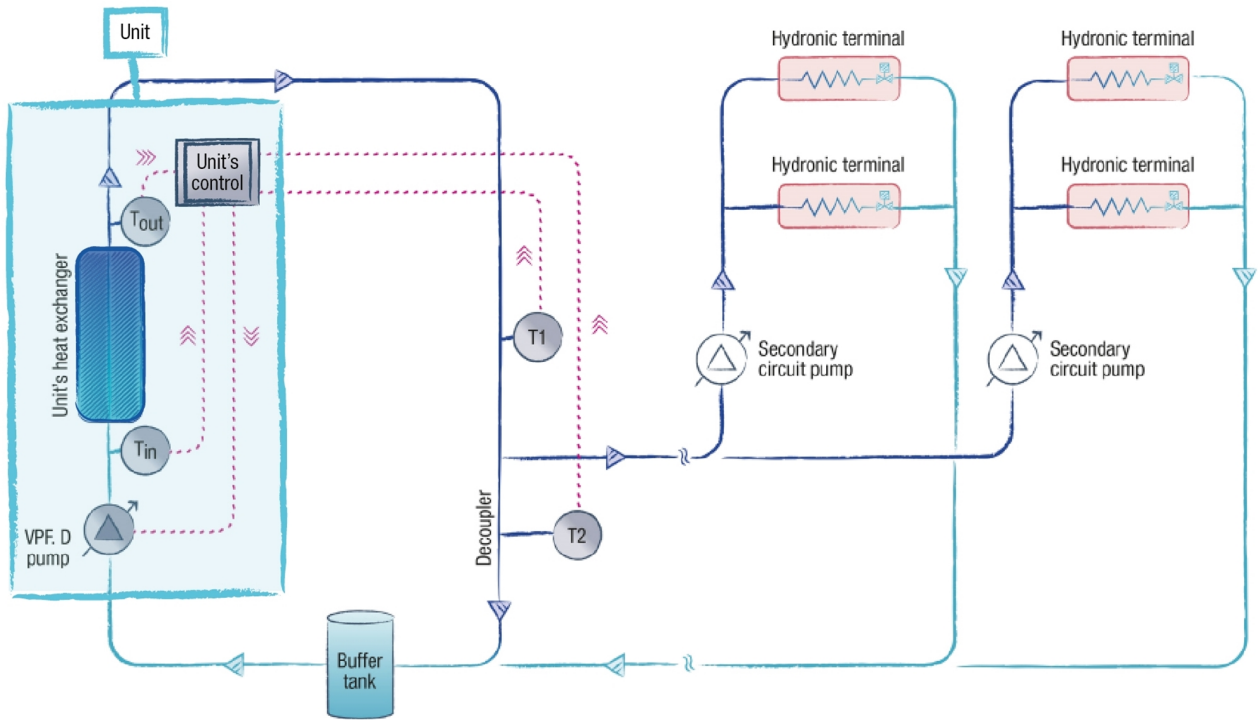

Plant diagram for multi-unit system with Multi Manager

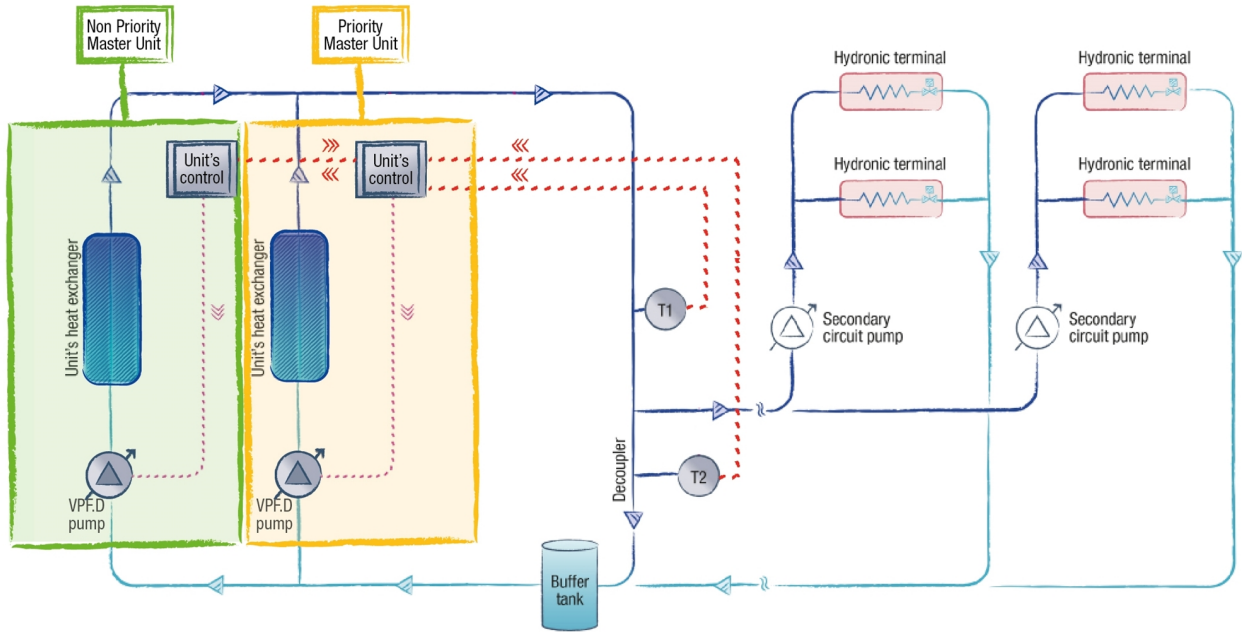

VPF.D - Operating logic

Water flow regulation

The VPF.D system monitors the temperature difference of the primary circuit (ΔT) (that corresponds to the temperature difference of the unit's heat exchanger in the case of a single unit system), and adjusts the primary circuit's pump speed in order to keep it within a defined range ($\Delta T_{min} \leq \Delta T \leq \Delta T_{max}$). The secondary circuit water flow is completely independent and is to be managed by the client.

- If $\Delta T_{min} \leq \Delta T \leq \Delta T_{max}$

The plant water flow is appropriate to the thermal load, the pump speed is kept constant.

- If $\Delta T < \Delta T_{min}$

The plant water flow exceeds what is necessary to properly cover the thermal load, the pump speed is reduced to save pump energy.

- If $\Delta T > \Delta T_{max}$

The plant water flow is too low to ensure the proper feed to the users, the pump speed is increased.

To prevent the returning water of the secondary circuit from recirculating through the decoupler and mixing with the delivery water, which would cause serious plant regulation problems, the VPF.D provides a safety function based on the temperatures, which are detected by two probes on the plant side: T1 on the unit delivery line and T2 on the hydraulic decoupler. If during the water flow regulation of the circuits, the flow direction in the decoupler reverses (detected temperatures $T1 < T2$), the system forces a quick increase of the primary water flow until the correct direction of the flow in the decoupler is restored (detected temperatures $T1 = T2$).

With the VPF.D system, the water flow can be reduced to 50% of the unit nominal water flow, with regards to the selection conditions, provided that the minimum water flow required by the unit's heat exchanger is respected (the control of the heat exchanger's minimum water flow is described below).

The pump speed regulation is performed with little progressive adjustments while continuously monitoring the values of both the temperature difference on the primary circuit and the temperatures of the probes T1 and T2. The absence of abrupt water flow changes prevents fluctuation due to possible conflicts with the unit's thermoregulation function (compressor regulation).

Control of the unit's minimum water flow

Under no circumstances can the primary circuit water flow be reduced below the minimum water flow required by the unit's heat exchanger.

The unit's minimum water flow is ensured by setting the minimum pump speed (service menu parameter).

Multi-unit systems

The VPF.D control logic is also the same for multi-unit systems.

The reading of the temperature difference on the primary circuit and the reading of the temperature probes T1 and T2 is managed by the multi-unit control system (Manager3000+, ClimaPRO+, Multi Manager Master). Each unit autonomously adjusts its pump speed on the basis of the information provided by the multi-unit control system.

When the plant load requests the activation of a stand-by unit, the multi-unit control system calculates the starting speed of its pump in order to avoid excessive water flow variation of the running units.

In case of multi-unit system with Multi Manager, at least one unit must be set as Priority Master (opt 1541). To grant redundancy to the system, more than one unit can be configured as Priority Master. All the Priority Masters must be connected to the temperature probes T1 and T2. The Multi Manager system only takes into account the signal read and sent by the Master of the moment.

The Non Priority Master cannot be connected to the temperature probes T1 and T2, and cannot managed the VPF.D function. In the event that a Non Priority Master is elected as the Master of the system, the VPF.D function is suspended.

VPF.D - Devices and installation

Dispositivo	Accessory name	
	VPF.D (SU, MM_PR) ⁽¹⁾	VPF.D(M3000, CPRO, MM_N-PR) ⁽²⁾
2 plant side NTC temperature sensors and related controller expansion board	Factory supplied (probes supplied without wells), installation is the client's responsibility ⁽³⁾	Factory supplied with the multi-unit external control system, Manager3000 or ClimaPRO (probes supplied without wells); installation is the client's responsibility Not included with option 1542 (Non Priority Master unit) ⁽³⁾⁽⁴⁾

(1) VPF.D for single unit plant and Priority Master unit

(2) VPF.D for multi-unit plant with external controller (Manager3000+ or ClimaPRO+) and Non Priority Master unit

(3) It is recommended to install the temperature probes as shown in the enclosed plant diagrams (T1 on the unit delivery line, T2 on the hydraulic decoupler)

(4) It is the customer's responsibility to configure the multi-unit control system (Manager3000+, ClimaPRO+ or Multi Manager) with option VPF.D.

The following table provides the indications for a correct hydraulic decoupler design.

Heat exchanger minimum flow (m ³ /h) ⁽¹⁾	Minimum hydraulic decoupler diameter
From 25 to 40	DN65 (2" ½)
Up to 60	DN80 (3")
Up to 100	DN100 (4")
Up to 150	DN125 (5")
Up to 225	DN150 (6")
Up to 375	DN200 (8")

(1) In case of a multi-unit system, the unit with the highest minimum water flow should be the reference.

14.2 Compressor rephasing and electromagnetic compatibility

Power Factor, Displacement Power Factor and Total Harmonic Distortion

The harmonic waves do not contribute to the absorption of active power from the power source, but their presence causes:

- The presence of voltage harmonics that worsen the quality of the grid power voltage thus leading to possible malfunctions of the loads connected to this power grid.
- The worsening of the unit power factor PF, resulting in higher charges for the client from the electricity distribution company.

The Power Factor PF of a system is equal to the ratio between the active power and the apparent power and it is formulated in the following way:

$$PF = \frac{1}{\sqrt{1 + THD_i^2}} DPF$$

DPF (Displacement Power Factor) is equal to the cosφ of the pure current wave.

THD (Total Harmonic Distorsion) is the rate which describes the amount of the harmonic distortion. In particular THDi refers to the current wave and THDv to the voltage wave.

It is therefore clear that, whenever harmonics are present, the Power Factor PF is different from the Displacement Power Factor, and that the heavier the harmonics are, the greater the difference is.

In general, frequency converters are characterized by an intrinsic constant DPF (Displacement Power Factor) value between 0.97 and 0.99, while the Power Factor PF varies according to the load conditions, usually becoming worse when load partialization increases.

The following table displays the values of Power Factor PF and current Total Harmonic Distortion for the units:

MECH-iF-G05 Size	Maximum		Nominal	
	PF [-]	THDi [%]	PF [-]	THDi [%]
0411	0,94	32%	0,93	38%
0802	0,94	32%	0,92	39%
0902	0,94	32%	0,93	38%

MAXIMUM: Values calculated at Maximum conditions (considering toughest possible load conditions)

The data shown above refer to measurement performed with the unit powered by 3% THDv electricity grid. Grids with different characteristics can lead to results that differ from those shown in the table.

**MITSUBISHI ELECTRIC
HYDRONICS & IT COOLING SYSTEMS S.p.A.**

Head Office:

Via Caduti di Cefalonia 1 - 36061 Bassano del Grappa (VI) - Italy

Tel (+39) 0424 509 500 - Fax (+39) 0424 509 509

www.melcohit.com