

SPLIT-TYPE AIR CONDITIONERS

Revision :A

- MUZ-EF25/35/42/50VG - [ER1] have been added.
- Part numbers of the inverter P.C. board assembly for MUZ-EF25/35/42/50VG- [ET1] have been changed.

OBB832 is void.

OUTDOOR UNIT



No. OBB832
REVISED EDITION-A

PARTS CATALOG

Models

MUZ-EF25VG - [E1], [ET1], [ER1]

MUZ-EF35VG - [E1], [ET1], [ER1]

MUZ-EF42VG - [E1], [ET1], [ER1]

MUZ-EF50VG - [E1], [ET1], [ER1]

MUZ-EF25VGH - [E1]

MUZ-EF35VGH - [E1]

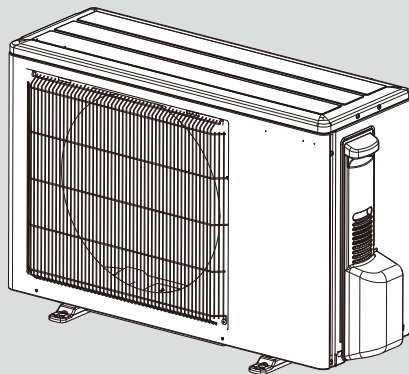

MUZ-EF25VG
MUZ-EF35VG
MUZ-EF42VG

CONTENTS

1. SERVICE PARTS LIST..... 2

SERVICE MANUAL (OBH832)

Revision A:

- MUZ-EF25/35/42/50VG - **ER1** have been added.
- Part numbers of the inverter P.C. board assembly for MUZ-EF25/35/42/50VG- **ET1** have been changed.

1 SERVICE PARTS LIST

MUZ-EF25VG MUZ-EF35VG

1-1. OUTDOOR UNIT STRUCTURAL PARTS AND FUNCTIONAL PARTS

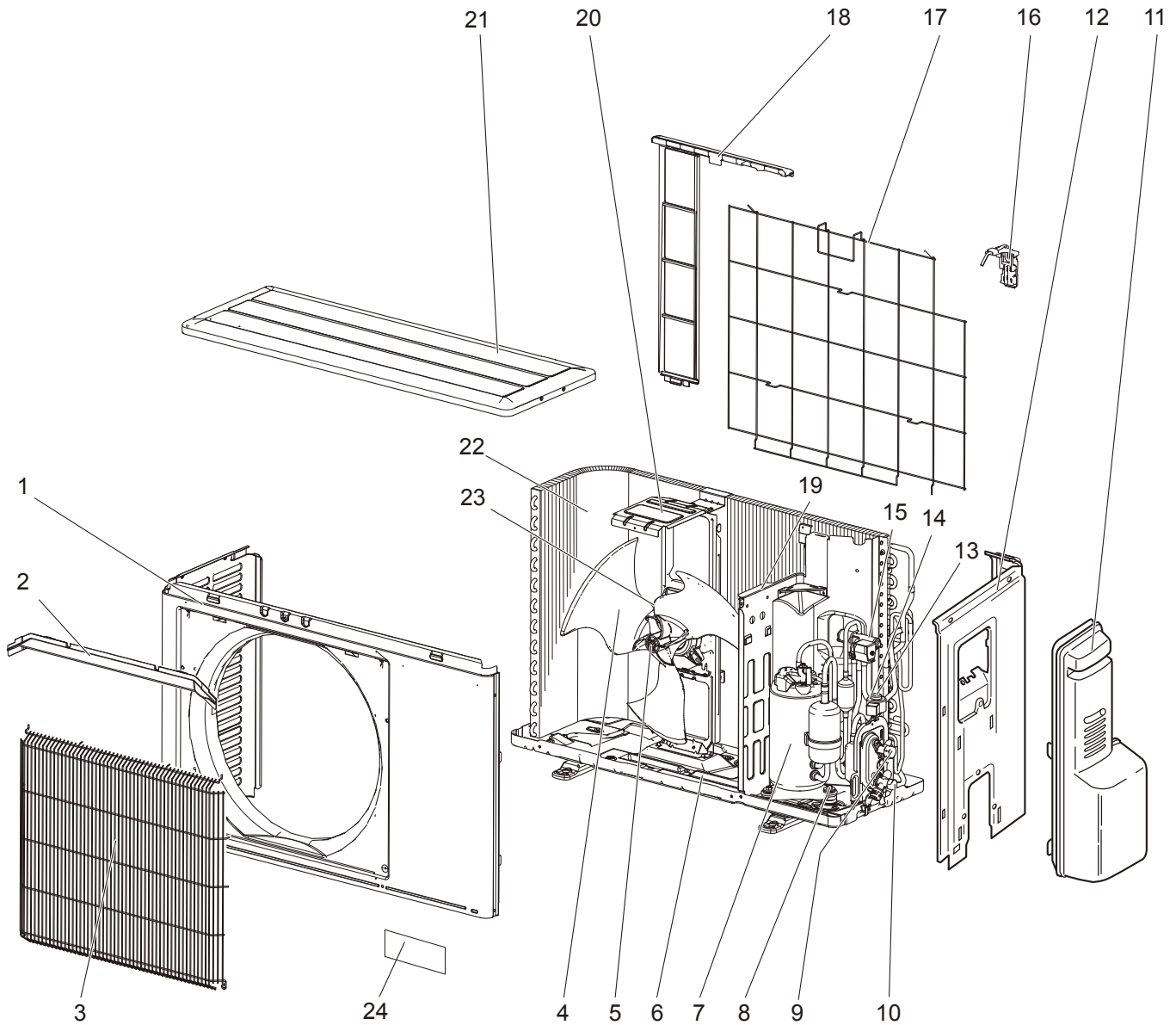

1-1. OUTDOOR UNIT STRUCTURAL PARTS AND FUNCTIONAL PARTS

1. The part quantity below indicates the required number of pieces per unit.
2. The circled No. indicates that the part is not shown in the figure.

No.	Part No.	Part Name	Symbol in Wiring Diagram	MUZ-EF25VG-E1	MUZ-EF25VG-E1	MUZ-EF25VG-E1	MUZ-EF35VG-E1	MUZ-EF35VG-E1	MUZ-EF35VG-E1	Remarks [Drawing No.]
1	E22 J63 232	CABINET		1	1	1	1	1	1	
2	E22 J63 531	ICE GUARD		1	1	1	1	1	1	
3	E22 Y84 521	WIRE GRILLE		1	1	1	1	1	1	
4	E22 95B 501	PROPELLER FAN		1	1	1	1	1	1	
5	————	PROPELLER FAN NUT		1	1	1	1	1	1	[SG12D375H03]
6	E22 Y84 290	BASE ASSEMBLY		1	1	1	1	1	1	
7	E22 R81 900	COMPRESSOR	MC	1	1	1	1	1	1	KVB073FYXMC
8	E22 065 506	COMPRESSOR RUBBER SET		3	3	3	3	3	3	3 RUBBERS/SET
9	E22 T66 662	STOP VALVE (LIQUID)		1	1	1	1	1	1	ø6.35
10	E22 T66 661	STOP VALVE (GAS)		1	1	1	1	1	1	ø9.52
11	E22 L59 245	SERVICE PANEL ASSEMBLY		1	1	1	1	1	1	
12	E22 G11 233	BACK PANEL ASSEMBLY		1	1	1	1	1	1	
13	E22 47H 645	EXPANSION VALVE ASSEMBLY		1	1	1				Includes LEV body, capillary tube ø4.0×ø2.4×240, ø3.0×ø2.0×100
13	E22 21G 645	EXPANSION VALVE ASSEMBLY					1	1	1	Includes LEV body, capillary tube ø4.0×ø2.4×240
14	E22 Y84 493	EXPANSION VALVE COIL	LEV	1	1	1	1	1	1	
15	E22 R81 961	4-WAY VALVE		1	1	1	1	1	1	
16	E22 928 079	THERMO HOLDER (AMBIENT)		1	1	1				
16	E22 930 079	THERMO HOLDER (AMBIENT)					1	1	1	
17	E22 47H 525	CONDENSER WIRE NET ASSEMBLY		1	1	1				
17	E22 930 525	CONDENSER WIRE NET ASSEMBLY					1	1	1	
18	E22 928 523	CONDENSER NET		1	1	1				
18	E22 930 523	CONDENSER NET					1	1	1	
19	E22 G10 293	SEPARATOR		1	1	1				
19	E22 G11 293	SEPARATOR					1	1	1	
20	E22 97B 515	MOTOR SUPPORT		1	1	1				
20	E22 47H 515	MOTOR SUPPORT					1	1	1	
21	E22 L85 297	TOP PANEL ASSEMBLY		1	1	1	1	1	1	
22	E22 47H 630	OUTDOOR HEAT EXCHANGER		1	1	1				
22	E22 Y84 630	OUTDOOR HEAT EXCHANGER					1	1	1	
23	E22 97B 301	OUTDOOR FAN MOTOR	MF	1	1	1	1	1	1	RC0J50-□□
24	————	TRADE MARK		1	1	1	1	1	1	[DK79G041H02]
25	E22 Y84 640	EXPANSION VALVE ASSEMBLY		1	1	1	1	1	1	
26	————	COMPRESSOR LEAD WIRE ASSEMBLY		1	1	1				[DM78R027G06]
26	————	COMPRESSOR LEAD WIRE ASSEMBLY					1	1	1	[DM78R027G15]
27	E22 838 704	DRAIN SOCKET		1	1	1	1	1	1	
28	————	THERMO HOLDER COVER		1	1	1	1	1	1	[SG25J917G05]
29	————	COMPRESSOR FELT (TOP)		1	1	1	1	1	1	[SQ33J347H01]
30	————	COMPRESSOR FELT (BODY)		1	1	1	1	1	1	[JU33Y270H15]
31	————	COMPRESSOR FELT (OUTER)		1	1	1	1	1	1	[SG33V226H04]

MUZ-EF25VG MUZ-EF35VG
1-2. OUTDOOR UNIT ELECTRICAL PARTS

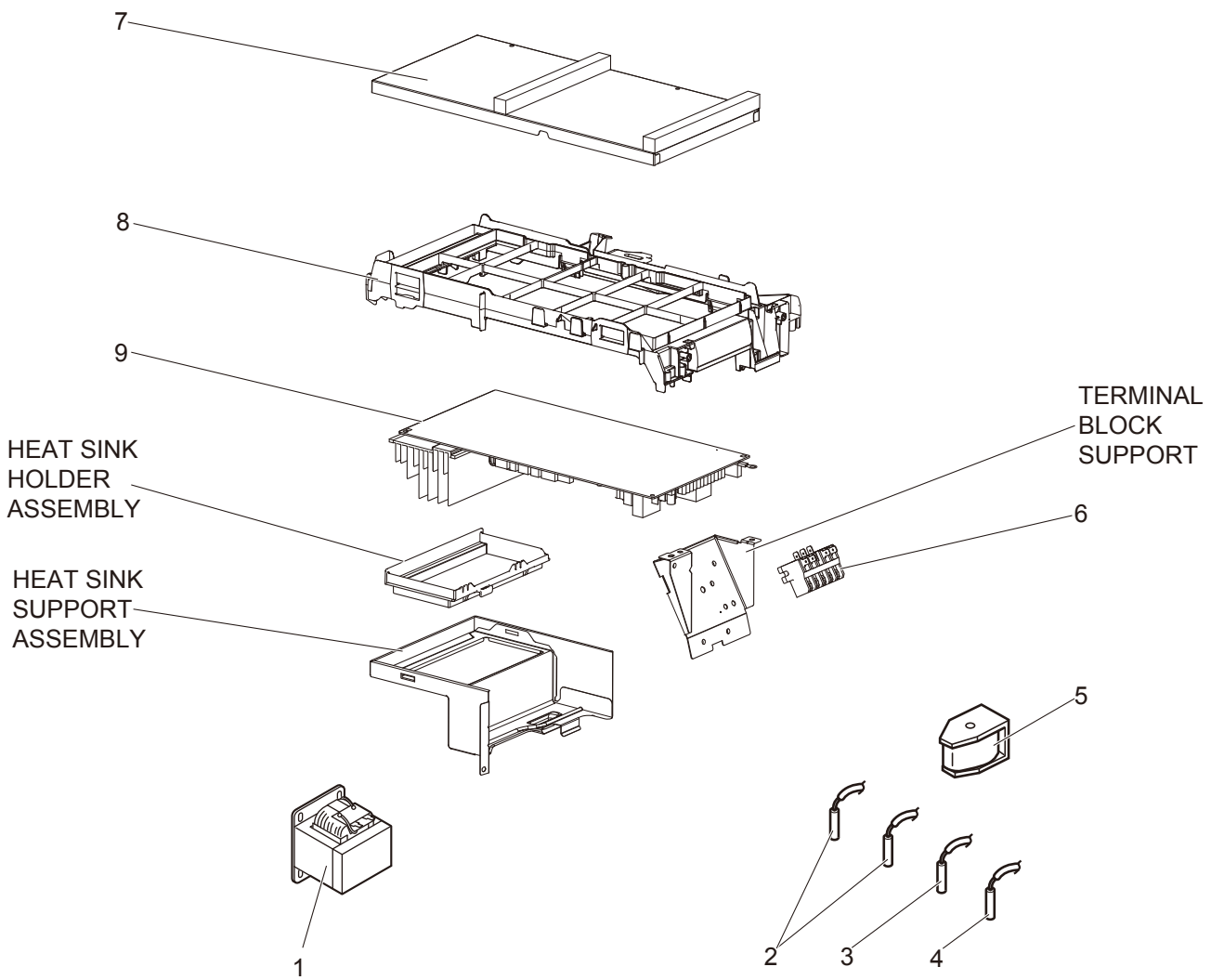



1-2. OUTDOOR UNIT ELECTRICAL PARTS

1. The part quantity below indicates the required number of pieces per unit.

No.	Part No.	Part Name	Symbol in Wiring Diagram	MUZ-EF25VG-ET						Remarks [Drawing No.]
				MUZ-EF25VG-ET	MUZ-EF25VG-ET1	MUZ-EF25VG-ER1	MUZ-EF35VG-ET	MUZ-EF35VG-ET1	MUZ-EF35VG-ER1	
1	E22 11C 337	REACTOR	L61	1	1	1				
1	E22 G11 337	REACTOR	L61				1	1	1	
2	E22 C34 306	THERMISTOR SET	RT61, RT62	1	1	1				DEFROST, DISCHARGE
2	E22 R81 306	THERMISTOR SET	RT61, RT62				1	1	1	DEFROST, DISCHARGE
3	E22 927 308	AMBIENT TEMPERATURE THERMISTOR	RT65	1	1	1	1	1	1	
4	E22 88F 307	OUTDOOR HEAT EXCHANGER TEMPERATURE THERMISTOR	RT68	1	1	1				
4	E22 P72 307	OUTDOOR HEAT EXCHANGER TEMPERATURE THERMISTOR	RT68				1	1	1	
5	E22 J47 490	R.V. COIL ASSEMBLY	21S4	1	1	1				
5	E22 R81 490	R.V. COIL ASSEMBLY	21S4				1	1	1	
6	E22 T95 374	TERMINAL BLOCK	TB1	1	1	1	1	1	1	5P (S1, S2, S3, L, N)
7	_____	P.C. BOARD COVER		1	1	1	1	1	1	[DY02B444G02], [DU33N535H56], [DU33N535HA7], [DM33T569H01] (4 PCS)
8	_____	P.C. BOARD SUPPORT		1	1	1	1	1	1	[RK00A867G01]
9	E22 47H 451	INVERTER P.C. BOARD ASSEMBLY		1	1	1				Includes heat sink and RT64
9	E22 48H 451	INVERTER P.C. BOARD ASSEMBLY					1	1	1	Includes heat sink and RT64

MUZ-EF25VGH MUZ-EF35VGH

1-3. OUTDOOR UNIT STRUCTURAL PARTS AND FUNCTIONAL PARTS

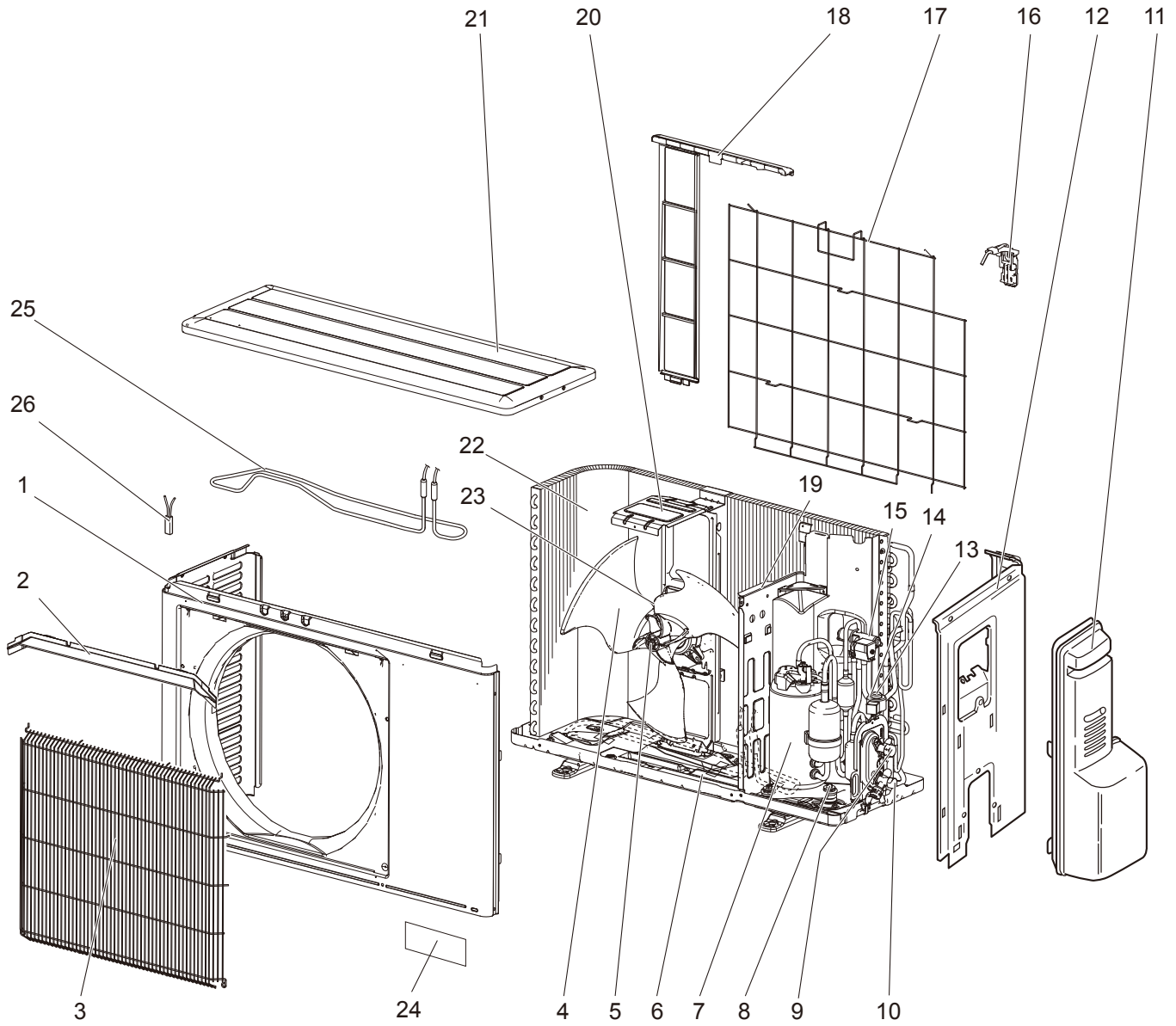

1-3. OUTDOOR UNIT STRUCTURAL PARTS AND FUNCTIONAL PARTS

1. The part quantity below indicates the required number of pieces per unit.
2. The circled No. indicates that the part is not shown in the figure.

No.	Part No.	Part Name	Symbol in Wiring Diagram	MUZ-EF25VGH-LE1	MUZ-EF35VGH-LE1	Remarks [Drawing No.]
1	E22 J63 232	CABINET		1	1	
2	E22 J63 531	ICE GUARD		1	1	
3	E22 Y84 521	WIRE GRILLE		1	1	
4	E22 95B 501	PROPELLER FAN		1	1	
5	————	PROPELLER FAN NUT		1	1	[SG12D375H03]
6	E22 Y96 290	BASE ASSEMBLY		1	1	
7	E22 R81 900	COMPRESSOR	MC	1	1	KVB073FYXMC
8	E22 065 506	COMPRESSOR RUBBER SET		3	3	3 RUBBERS/SET
9	E22 T66 662	STOP VALVE (LIQUID)		1		ø6.35
10	E22 T66 661	STOP VALVE (GAS)			1	ø9.52
11	E22 L59 245	SERVICE PANEL ASSEMBLY		1	1	
12	E22 G13 233	BACK PANEL ASSEMBLY		1	1	
13	E22 47H 645	EXPANSION VALVE ASSEMBLY		1		Includes LEV body, capillary tube ø4.0×ø2.4×240, ø3.0×ø2.0×100
13	E22 21G 645	EXPANSION VALVE ASSEMBLY			1	Includes LEV body, capillary tube ø4.0×ø2.4×240
14	E22 Y84 493	EXPANSION VALVE COIL	LEV	1	1	
15	E22 R81 961	4-WAY VALVE		1	1	
16	E22 928 079	THERMO HOLDER (AMBIENT)		1		
16	E22 930 079	THERMO HOLDER (AMBIENT)			1	
17	E22 47H 525	CONDENSER WIRE NET ASSEMBLY		1		
17	E22 930 525	CONDENSER WIRE NET ASSEMBLY			1	
18	E22 928 523	CONDENSER NET		1		
18	E22 930 523	CONDENSER NET			1	
19	E22 G13 293	SEPARATOR		1		
19	E22 G14 293	SEPARATOR			1	
20	E22 97B 515	MOTOR SUPPORT		1		
20	E22 47H 515	MOTOR SUPPORT			1	
21	E22 L85 297	TOP PANEL ASSEMBLY		1	1	
22	E22 47H 630	OUTDOOR HEAT EXCHANGER		1		
22	E22 Y84 630	OUTDOOR HEAT EXCHANGER			1	
23	E22 97B 301	OUTDOOR FAN MOTOR	MF	1	1	RC0J50-□□
24	————	TRADE MARK		1	1	[DK79G041H02]
25	E22 Y96 526	DEFROST HEATER	H	1	1	
26	E22 D65 381	HEATER PROTECTOR ASSEMBLY	26H	1	1	
27	E22 Y84 640	EXPANSION VALVE		1	1	
28	————	COMPRESSOR LEAD WIRE ASSEMBLY		1		[DM78R027G06]
28	————	COMPRESSOR LEAD WIRE ASSEMBLY			1	[DM78R027G15]
29	————	THERMO HOLDER COVER		1	1	[SG25J917G05]
30	————	COMPRESSOR FELT (TOP)		1	1	[SQ33J347H01]
31	————	COMPRESSOR FELT (BODY)		1	1	[JU33Y270H15]
32	————	COMPRESSOR FELT (OUTER)		1	1	[SG33V226H04]

MUZ-EF25VGH MUZ-EF35VGH
1-4. OUTDOOR UNIT ELECTRICAL PARTS

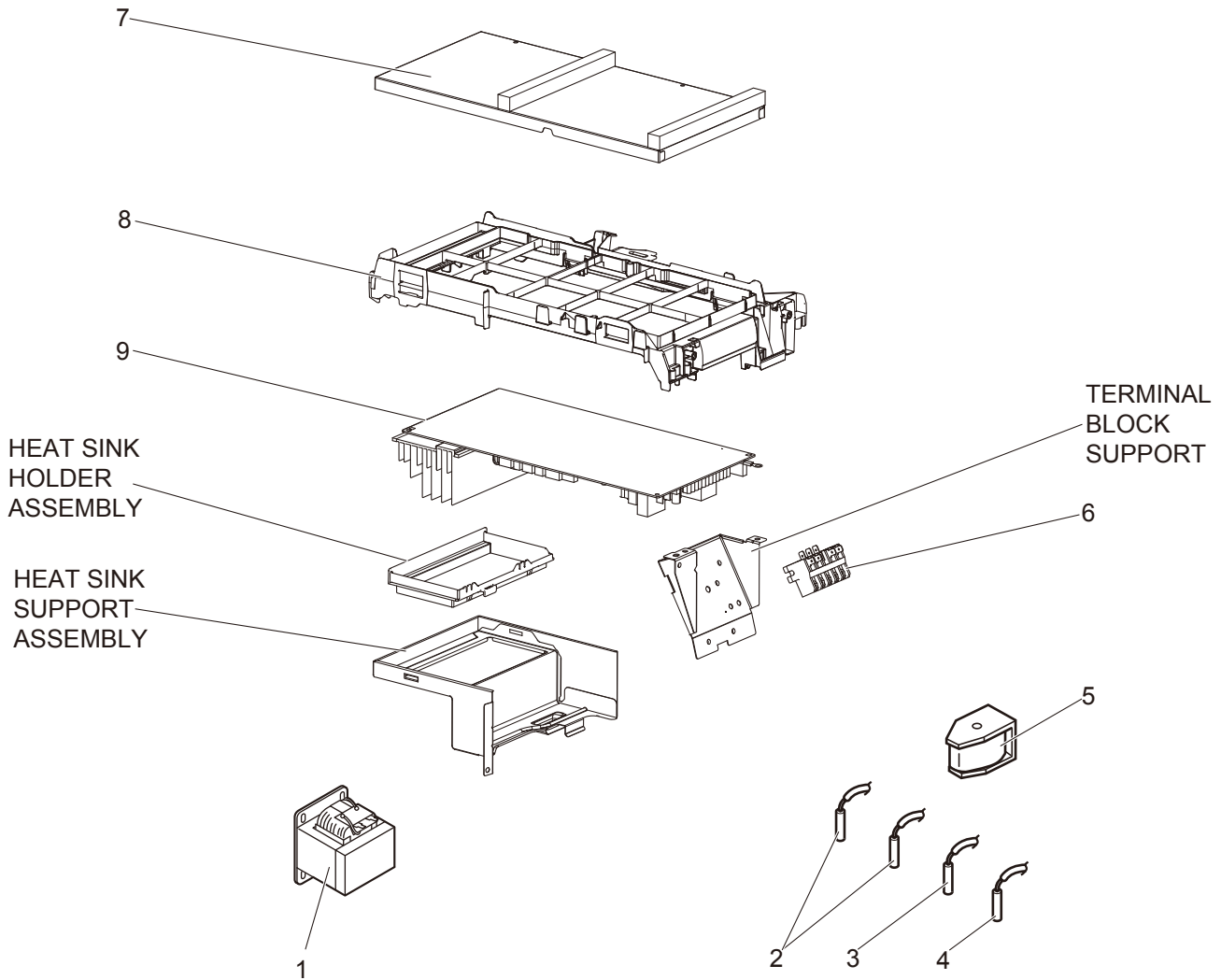

1-4. OUTDOOR UNIT ELECTRICAL PARTS

1. The part quantity below indicates the required number of pieces per unit.

No.	Part No.	Part Name	Symbol in Wiring Diagram	MUZ-EF25VGH-[ET]	MUZ-EF35VGH-[ET]	Remarks [Drawing No.]
1	E22 11C 337	REACTOR	L61	1		
1	E22 G11 337	REACTOR	L61		1	
2	E22 C34 306	THERMISTOR SET	RT61, RT62	1		DEFROST, DISCHARGE
2	E22 R81 306	THERMISTOR SET	RT61, RT62		1	DEFROST, DISCHARGE
3	E22 927 308	AMBIENT TEMPERATURE THERMISTOR	RT65	1	1	
4	E22 88F 307	OUTDOOR HEAT EXCHANGER TEMPERATURE THERMISTOR	RT68	1		
4	E22 P72 307	OUTDOOR HEAT EXCHANGER TEMPERATURE THERMISTOR	RT68		1	
5	E22 J47 490	R.V. COIL ASSEMBLY	21S4	1		
5	E22 R81 490	R.V. COIL ASSEMBLY	21S4		1	
6	E22 T95 374	TERMINAL BLOCK	TB1	1	1	5P (S1, S2, S3, L, N)
7	————	P.C. BOARD COVER		1	1	[DY02B444G02], [DU33N535H56], [DU33N535HA7], [DM33T569H01] (4 PCS)
8	————	P.C. BOARD SUPPORT		1	1	[RK00A867G01]
9	E22 51H 451	INVERTER P.C. BOARD ASSEMBLY		1		Includes heat sink and RT64
9	E22 52H 451	INVERTER P.C. BOARD ASSEMBLY			1	Includes heat sink and RT64

MUZ-EF42VG

1-5. OUTDOOR UNIT STRUCTURAL PARTS AND FUNCTIONAL PARTS

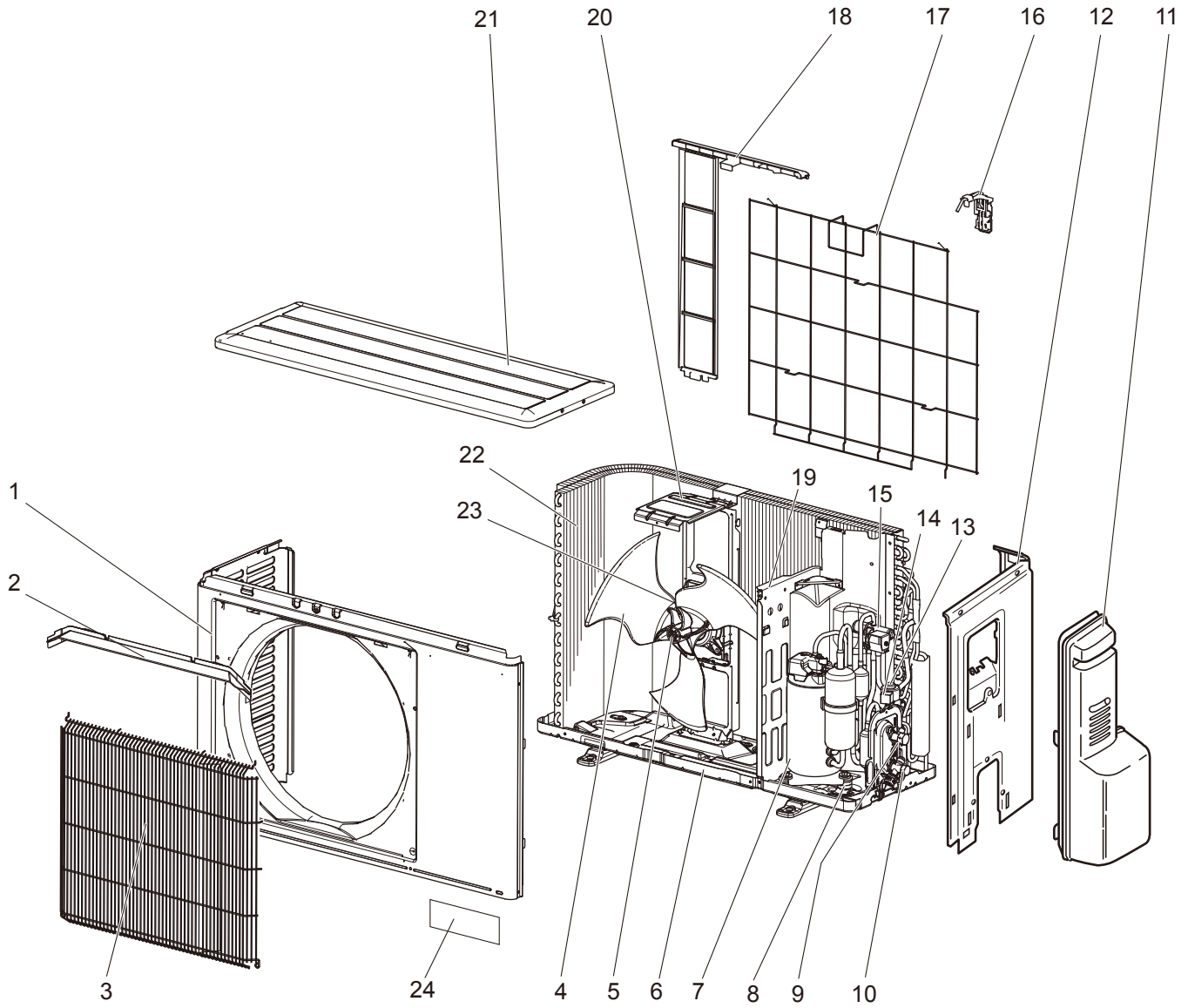

1-5. OUTDOOR UNIT STRUCTURAL PARTS AND FUNCTIONAL PARTS

1. The part quantity below indicates the required number of pieces per unit.
2. The circled No. indicates that the part is not shown in the figure.

No.	Part No.	Part Name	Symbol in Wiring Diagram	MUZ-EF42VG-ET	MUZ-EF42VG-ET1	MUZ-EF42VG-ERT1	Remarks [Drawing No.]
1	E22 J63 232	CABINET		1	1	1	
2	E22 J63 531	ICE GUARD		1	1	1	
3	E22 Y84 521	WIRE GRILLE		1	1	1	
4	E22 95B 501	PROPELLER FAN		1	1	1	
5	————	PROPELLER FAN NUT		1	1	1	[SG12D375H03]
6	E22 Y84 290	BASE ASSEMBLY		1	1	1	
7	E22 R83 900	COMPRESSOR	MC	1	1	1	SVB130FBBMT
8	E22 C34 506	COMPRESSOR RUBBER SET		3	3	3	3 RUBBERS/SET
9	E22 T66 662	STOP VALVE (LIQUID)		1	1	1	ø6.35
10	E22 T66 661	STOP VALVE (GAS)		1	1	1	ø9.52
11	E22 L59 245	SERVICE PANEL ASSEMBLY		1	1	1	
12	E22 G15 233	BACK PANEL ASSEMBLY		1	1	1	
13	E22 21G 645	EXPANSION VALVE ASSEMBLY		1	1	1	Includes LEV body, capillary tube ø4.0×ø2.4×240
14	E22 Y84 493	EXPANSION VALVE COIL	LEV	1	1	1	
15	E22 R81 961	4-WAY VALVE		1	1	1	
16	E22 930 079	THERMO HOLDER (AMBIENT)		1	1	1	
17	E22 930 525	CONDENSER WIRE NET ASSEMBLY		1	1	1	
18	E22 930 523	CONDENSER NET		1	1	1	
19	E22 G11 293	SEPARATOR		1	1	1	
20	E22 47H 515	MOTOR SUPPORT		1	1	1	
21	E22 L85 297	TOP PANEL ASSEMBLY		1	1	1	
22	E22 Y84 630	OUTDOOR HEAT EXCHANGER		1	1	1	
23	E22 97B 301	OUTDOOR FAN MOTOR	MF	1	1	1	RC0J50-□□
24	————	TRADE MARK		1	1	1	[DK79G041H02]
②⑤	E22 Y84 640	EXPANSION VALVE		1	1	1	
②⑥	————	COMPRESSOR LEAD WIRE ASSEMBLY		1	1	1	[DM78R027G16]
②⑦	E22 838 704	DRAIN SOCKET		1	1	1	
②⑧	————	THERMO HOLDER COVER		1	1	1	[SG25J917G05]
②⑨	————	COMPRESSOR FELT (TOP)		1	1	1	[SQ33J347H02]
③⑩	————	COMPRESSOR FELT (BODY)		1	1	1	[JU33Y270H15]
③①	————	COMPRESSOR FELT (OUTER)		1	1	1	[SG33V226H04]

MUZ-EF42VG

1-6. OUTDOOR UNIT ELECTRICAL PARTS

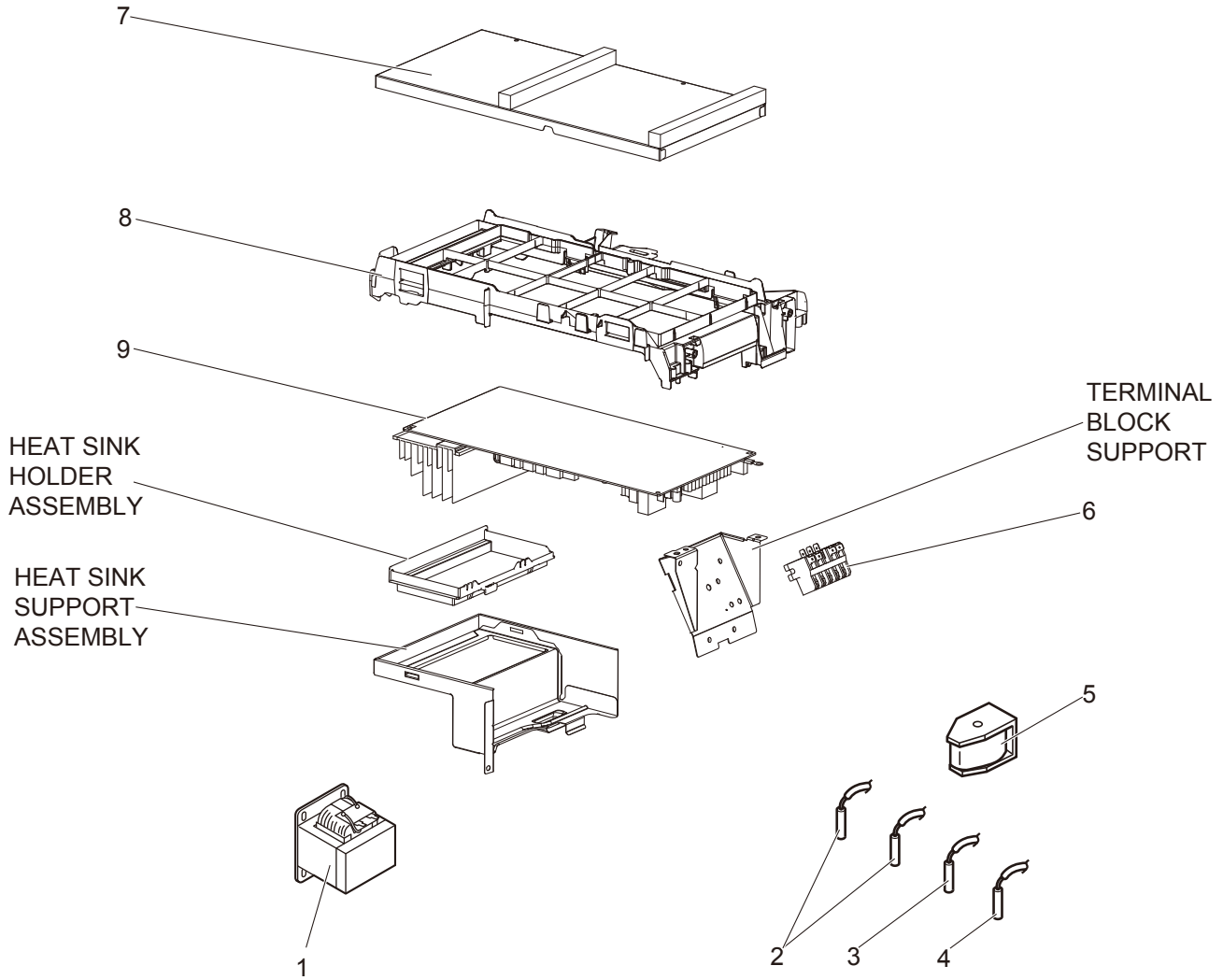

1-6. OUTDOOR UNIT ELECTRICAL PARTS

1. The part quantity below indicates the required number of pieces per unit.

No.	Part No.	Part Name	Symbol in Wiring Diagram	MUZ-EF42VG-[ET]	MUZ-EF42VG-[ET1]	MUZ-EF42VG-[ER1]	Remarks [Drawing No.]
1	E22 G11 337	REACTOR	L61	1	1	1	
2	E22 R81 306	THERMISTOR SET	RT61, RT62	1	1	1	DEFROST, DISCHARGE
3	E22 927 308	AMBIENT TEMPERATURE THERMISTOR	RT65	1	1	1	
4	E22 P72 307	OUTDOOR HEAT EXCHANGER TEMPERATURE THERMISTOR	RT68	1	1	1	
5	E22 R81 490	R.V. COIL ASSEMBLY	21S4	1	1	1	
6	E22 T95 374	TERMINAL BLOCK	TB1	1	1	1	5P (S1, S2, S3, L, N)
7	————	P.C. BOARD COVER		1	1	1	[DY02B444G02], [DU33N535H56], [DU33N535HA7], [DM33T569H01] (4 PCS)
8	————	P.C. BOARD SUPPORT		1	1	1	[RK00A867G01]
9	E22 49H 451	INVERTER P.C. BOARD ASSEMBLY		1	1	1	Includes heat sink and RT64

MUZ-EF50VG

1-7. OUTDOOR UNIT STRUCTURAL PARTS, ELECTRICAL PARTS AND FUNCTIONAL PARTS

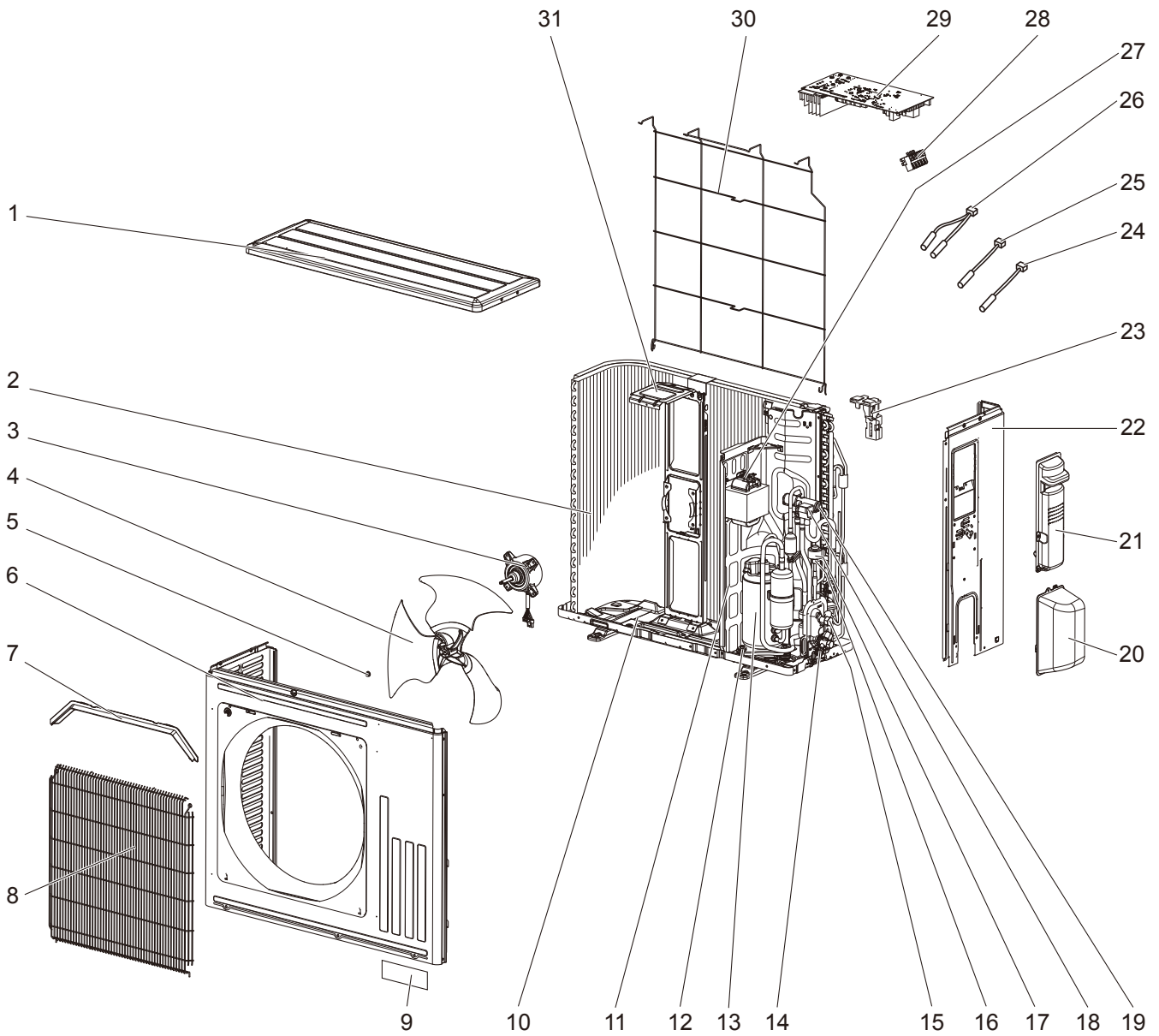

1-7. OUTDOOR UNIT STRUCTURAL PARTS, ELECTRICAL PARTS AND FUNCTIONAL PARTS

1. The part quantity below indicates the required number of pieces per unit.
2. The circled No. indicates that the part is not shown in the figure.

No.	Part No.	Part Name	Symbol in Wiring Diagram	MUZ-EF50VG-ET	MUZ-EF50VG-ET1	MUZ-EF50VG-ERT	Remarks [Drawing No.]
1	E22 Y86 297	TOP PANEL		1	1	1	
2	E22 Y86 630	OUTDOOR HEAT EXCHANGER		1	1	1	
3	E22 Y86 301	OUTDOOR FAN MOTOR	MF	1	1	1	RC0J50-□□
4	E22 Y86 501	PROPELLER FAN		1	1	1	
5	————	PROPELLER FAN NUT		1	1	1	[SG12D375H03]
6	E22 Y86 232	CABINET		1	1	1	
7	E22 Y86 531	ICE GUARD		1	1	1	
8	E22 Y86 521	GRILLE		1	1	1	
9	————	TRADE MARK		1	1	1	[DK79G041H02]
10	E22 Y84 290	BASE		1	1	1	
11	E22 Y86 293	SEPARATOR		1	1	1	
12	E22 C34 506	COMPRESSOR RUBBER SET		3	3	3	3 RUBBERS/SET
13	E22 R83 900	COMPRESSOR	MC	1	1	1	SVB130FBBMT
14	E22 Y86 661	STOP VALVE (GAS)		1	1	1	ø9.52
15	E22 Y86 662	STOP VALVE (LIQUID)		1	1	1	ø6.35
16	E22 41G 645	EXPANSION VALVE		1	1	1	Includes LEV body, capillary tube
17	E22 Y84 493	EXPANSION VALVE COIL	LEV	1	1	1	
18	E22 Y86 490	R.V. COIL	21S4	1	1	1	
19	E22 J44 961	4-WAY VALVE		1	1	1	
20	E22 Y86 650	VALVE COVER		1	1	1	
21	E22 Y86 245	SERVICE PANEL		1	1	1	
22	E22 Y86 233	BACK PANEL (OUT)		1	1	1	
23	E22 22A 079	THERMO HOLDER		1	1	1	
24	E22 Y86 309	AMBIENT TEMPERATURE THERMISTOR	RT65	1	1	1	
25	E22 C34 307	OUTDOOR HEAT EXCHANGER TEMPERATURE THERMISTOR	RT68	1	1	1	
26	E22 Y86 306	THERMISTOR SET	RT61, RT62	1	1	1	DEFROST, DISCHARGE
27	E22 H21 337	REACTOR	L61	1	1	1	
28	E22 T95 374	TERMINAL BLOCK	TB1	1	1	1	5 P
29	E22 50H 451	INVERTER P.C. BOARD		1	1	1	Includes heat sink and RT64
30	E22 Y86 525	CONDENSER WIRE NET		1	1	1	
31	E22 Y86 515	MOTOR SUPPORT		1	1	1	
32	E22 838 704	DRAIN SOCKET		1	1	1	
33	E22 Y84 640	EXPANSION VALVE		1	1	1	LEV body
34	E22 J47 936	CAPILLARY TUBE		1	1	1	ø4.0 × ø2.4 × 240
35	E22 F35 936	CAPILLARY TUBE		2	2	2	ø3.0 × ø2.0 × 210
36	————	PB SUPPORT		1	1	1	[RK00A627G01]
37	————	PB COVER		1	1	1	[DY00B947G02]
38	————	COMPRESSOR LEAD WIRE ASSEMBLY		1	1	1	[DY78C464G02]
39	————	COMPRESSOR FELT (TOP)		1	1	1	[SQ33J842H03]
40	————	COMPRESSOR FELT (BODY)		1	1	1	[SQ33Y585H02]
41	————	COMPRESSOR FELT (OUTER)		1	1	1	[SG33V226H04]

2-1. DEFROST HEATER

Model	Parts No.
MUZ-EF42VG	MAC-643BH-E
MUZ-EF50VG	MAC-646BH-E

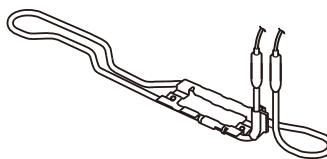
**NOTE:**

- Attaching the Freeze-prevention heater "MAC-643BH-E Anti-Freeze Heater" (for drain pan) to MUZ-EF25/35VG requires installation of the INVERTER P.C. BOARD for MUZ-EF25/35VGH. Order the INVERTER P.C. BOARD for MUZ-EF25/35VGH as needed.
- Refer to the installation manual for the installation.

MITSUBISHI ELECTRIC CORPORATION

HEAD OFFICE: TOKYO BUILDING, 2-7-3, MARUNOUCHI, CHIYODA-KU, TOKYO 100-8310, JAPAN

© Copyright 2019 MITSUBISHI ELECTRIC CORPORATION

Issued: Jun. 2020 No. OBB832 REVISED EDITION-A

Published: Feb. 2019. No. OBB832

Made in Japan

Specifications are subject to change without notice.