

SPLIT-TYPE AIR CONDITIONERS

**Revision A:**  
• Pats numbers of "AIR PURIFYING DE-  
VICE" and "AIR PURIFYING DEVICE  
SUPPORT" have been changed.  
OBB930 is void.

# INDOOR UNIT

**No. OBB930**  
**REVISED EDITION-A**

# PARTS CATALOG

## Models

**MSZ-AY25VGK** - E6  
**MSZ-AY35VGK** - E6  
**MSZ-AY42VGK** - E6  
**MSZ-AY50VGK** - E6

**MSZ-AY25VGKP** - E6  
**MSZ-AY35VGKP** - E6  
**MSZ-AY42VGKP** - E6  
**MSZ-AY50VGKP** - E6



## CONTENTS

1. SERVICE PARTS LIST .....	2
2. OPTIONAL PARTS .....	7

**SERVICE MANUAL (OBH930)**

**Revision A:**

• Pats numbers of "AIR PURIFYING DEVICE" and "AIR PURIFYING DEVICE SUPPORT" have been changed.

# 1 SERVICE PARTS LIST

MSZ-AY25VGK- [E6]  
MSZ-AY25VGKP- [E6]

MSZ-AY35VGK- [E6]  
MSZ-AY35VGKP- [E6]

MSZ-AY42VGK- [E6]  
MSZ-AY42VGKP- [E6]

MSZ-AY50VGK- [E6]  
MSZ-AY50VGKP- [E6]

## 1-1. INDOOR UNIT STRUCTURAL PARTS

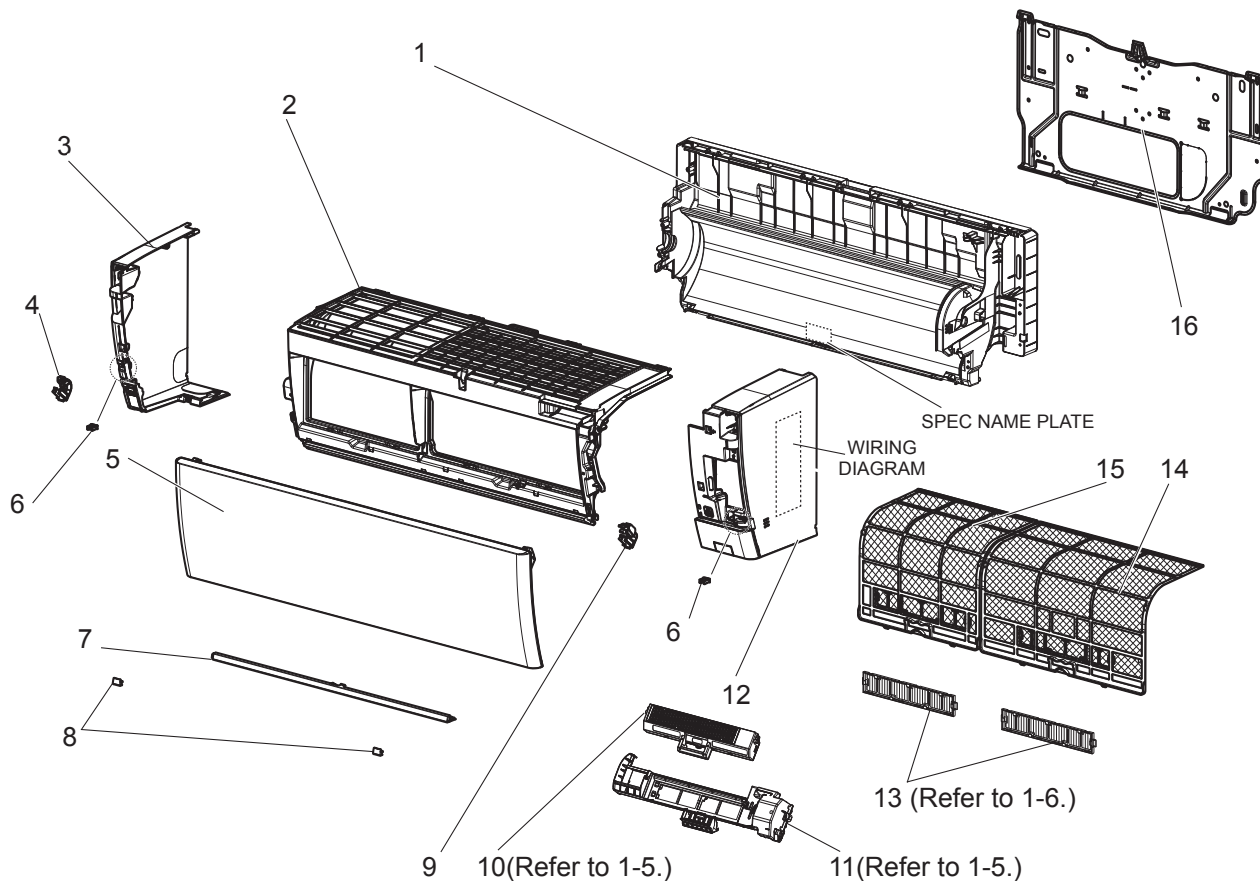

## 1-2. ACCESSORY AND REMOTE CONTROLLER

## 1-3. INDOOR UNIT HEAT EXCHANGER

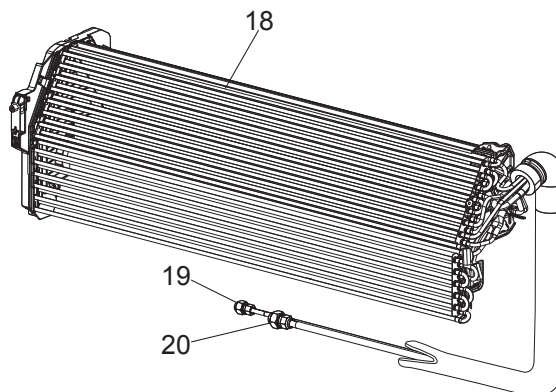
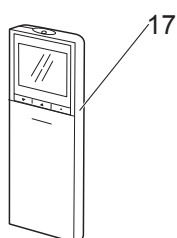

## 1-1. INDOOR UNIT STRUCTURAL PARTS

1. The part quantity below indicates the required number of pieces per unit.

No.	Part No.	Part name	MSZ-AY25VGK - [E6]	MSZ-AY35VGK - [E6]	MSZ-AY42VGK - [E6]	MSZ-AY50VGK - [E6]	MSZ-AY25VGKP - [E6]	MSZ-AY35VGKP - [E6]	MSZ-AY42VGKP - [E6]	MSZ-AY50VGKP - [E6]	Symbol in Wiring Diagram	Remarks
1	T2W EC7 234	BOX ASSEMBLY	1	1	1	1	1	1	1	1		Not includes SPEC NAME PLATE
2	T2W EBF 002	PANEL (FRONT) ASSEMBLY	1	1	1	1	1	1	1	1		
3	T2W EAY 057	PANEL (LEFT) ASSEMBLY	1	1	1	1	1	1	1	1		Includes No. 4,6
4	T2W EAK 039	ARM HOLDER (LEFT)	1	1	1	1	1	1	1	1		
5	T2W EDJ 010	FRONT PANEL	1	1	1	1	1	1	1	1		
6	T2W EA3 008	CATCH	2	2	2	2	2	2	2	2		
7	T2W EA9 003	PANEL (UNDER) ASSEMBLY	1	1	1	1	1	1	1	1		
8	T2W EAN 067	SCREW CAP	2	2	2	2	2	2	2	2		
9	T2W EAL 039	ARM HOLDER (RIGHT)	1	1	1	1	1	1	1	1		
10	G2W 001 428	AIR PURIFYING DEVICE					1	1	1	1		
11	G2W 001 418	AIR PURIFYING DEVICE SUPPORT					1	1	1	1		
12	T2W EB4 006	PANEL (RIGHT) ASSEMBLY	1	1	1	1						Includes No. 6,9 Not including WIRING DIAGRAM
12	T2W EB5 006	PANEL (RIGHT) ASSEMBLY					1	1	1	1		Includes No. 6,9 Not including WIRING DIAGRAM
13	—	AIR CLEANING FILTER (V BLOCKING FILTER)	2	2	2	2						2 PCS/SET MAC2470FT-E
14	T2W ECA 100	AIR FILTER_RIGHT	1	1	1	1	1	1	1	1		1 PC/SET
15	T2W ECC 100	AIR FILTER_LEFT	1	1	1	1	1	1	1	1		1 PC/SET
16	T2W EAC 970	INSTALLATION PLATE	1	1	1	1	1	1	1	1		

## 1-2. ACCESSORY AND REMOTE CONTROLLER

1. The part quantity below indicates the required number of pieces per unit.

No.	Part No.	Part name	MSZ-AY25VGK - [E6]	MSZ-AY35VGK - [E6]	MSZ-AY42VGK - [E6]	MSZ-AY50VGK - [E6]	MSZ-AY25VGKP - [E6]	MSZ-AY35VGKP - [E6]	MSZ-AY42VGKP - [E6]	MSZ-AY50VGKP - [E6]	Symbol in Wiring Diagram	Remarks
17	G2W 007 400	REMOTE CONTROLLER	1	1	1	1						SH22Q
17	G2W 010 400	REMOTE CONTROLLER					1	1	1	1		SH22R

## 1-3. INDOOR UNIT HEAT EXCHANGER

1. The part quantity below indicates the required number of pieces per unit.

No.	Part No.	Part name	MSZ-AY25VGK - [E6]	MSZ-AY35VGK - [E6]	MSZ-AY42VGK - [E6]	MSZ-AY50VGK - [E6]	MSZ-AY25VGKP - [E6]	MSZ-AY35VGKP - [E6]	MSZ-AY42VGKP - [E6]	MSZ-AY50VGKP - [E6]	Symbol in Wiring Diagram	Remarks
18	T2W EM1 620	INDOOR HEAT EXCHANGER	1	1			1	1				Includes No. 19, 20
18	T2W EM2 620	INDOOR HEAT EXCHANGER			1	1			1	1		Includes No. 19, 20
19	G2W 001 605	UNION (LIQUID)	1	1	1	1	1	1	1	1		'1/4" (ø6.35)
20	G2W 002 605	UNION (GAS)	1	1	1	1	1	1	1	1		'3/8" (ø9.52)

MSZ-AY25VGK- E6

MSZ-AY35VGK- E6

MSZ-AY42VGK- E6

MSZ-AY50VGK- E6

MSZ-AY25VGKP- E6

MSZ-AY35VGKP- E6

MSZ-AY42VGKP- E6

MSZ-AY50VGKP- E6

### 1-4. INDOOR UNIT ELECTRICAL PARTS AND FUNCTIONAL PARTS

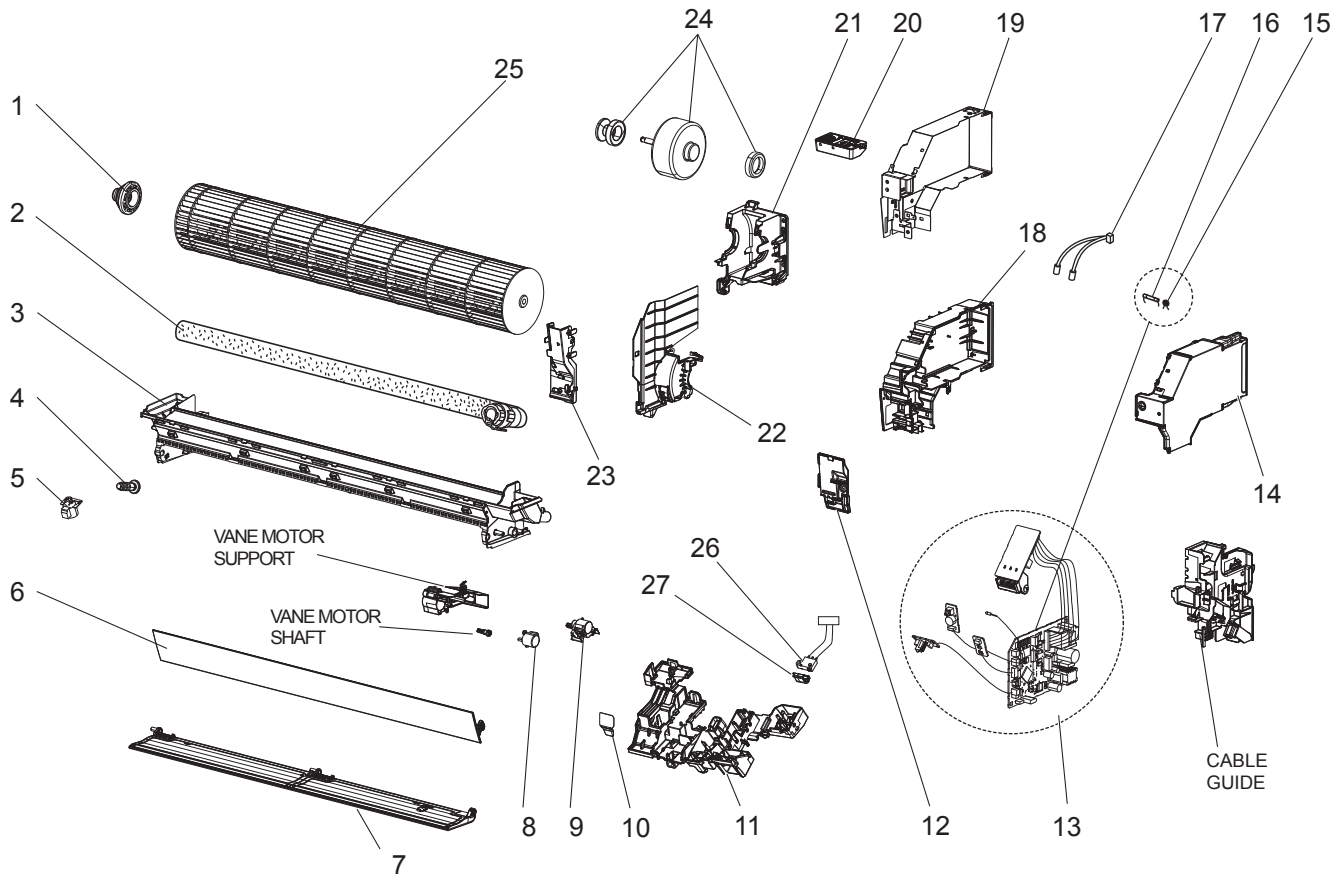

## 1-4. INDOOR UNIT ELECTRICAL PARTS AND FUNCTIONAL PARTS

1. The part quantity below indicates the required number of pieces per unit.
2. The circled No. indicates that the part is not shown in the figure.

No.	Part No.	Part name	MSZ-A Series								Symbol in Wiring Diagram	Remarks [Drawing No.]
			MSZ-A25VGK - [E6]	MSZ-A35VGK - [E6]	MSZ-A42VGK - [E6]	MSZ-A50VGK - [E6]	MSZ-A25VGKP - [E6]	MSZ-A35VGKP - [E6]	MSZ-A42VGKP - [E6]	MSZ-A50VGKP - [E6]		
1	T2W EA2 509	BEARING MOUNT ASSEMBLY	1	1	1	1	1	1	1	1		Includes sleeve bearing
2	T2W EAC 703	DRAIN HOSE ASSEMBLY (SHORT)	1	1	1	1	1	1	1	1		L=520 mm
3	T2W ECG 235	NOZZLE ASSEMBLY	1	1	1	1	1	1	1	1		
4	T2W EA1 707	DRAIN CAP	1	1	1	1	1	1	1	1		
5	G2W 001 320	VANE MOTOR (VERTICAL)	1	1	1	1	1	1	1	1	MV3	RIGHT & LEFT
6	T2W EDR 041	HORIZONTAL VANE (UPPER) ASSEMBLY	1	1	1	1	1	1	1	1		Includes shaft
7	T2W EDS 041	HORIZONTAL VANE (LOWER) ASSEMBLY	1	1	1	1	1	1	1	1		Includes shaft
8	G2W 003 315	VANE MOTOR (HORIZONTAL) (UPPER)	1	1	1	1	1	1	1	1	MV1	UP & DOWN
9	G2W 002 315	VANE MOTOR (HORIZONTAL) (LOWER)	1	1	1	1	1	1	1	1	MV2	UP & DOWN
10	—	SWITCH SHEET	1	1	1	1	1	1	1	1		[ DY79C595H01 ]
11	—	DISPLAY AND RECEIVER P.C. BOARD HOLDER ASSEMBLY	1	1	1	1	1	1	1	1		[ DY25Y050G03 ]
12	—	V.A. CLAMP ASSEMBLY	1	1	1	1	1	1	1	1		[ DK00G532G02 ]
13	T2W FMJ 450	ELECTRONIC CONTROL P.C. BOARD	1									Includes RECEIVER P.C. BOARD, DISPLAY P.C. BOARD, SWITCH/BUZZER P.C. BOARD, TERMINAL P.C. BOARD and ROOM TEMPERATURE THERMISTOR (RT11)
13	T2W FMK 450	ELECTRONIC CONTROL P.C. BOARD		1								
13	T2W FML 450	ELECTRONIC CONTROL P.C. BOARD			1							
13	T2W FMM 450	ELECTRONIC CONTROL P.C. BOARD				1						
13	T2W FMN 450	ELECTRONIC CONTROL P.C. BOARD					1					
13	T2W FMP 450	ELECTRONIC CONTROL P.C. BOARD						1				
13	T2W FMR 450	ELECTRONIC CONTROL P.C. BOARD							1			
13	T2W FMS 450	ELECTRONIC CONTROL P.C. BOARD								1		
14	—	PB-COVER (RIGHT)	1	1	1	1	1	1	1	1		[ DK00G531G02 ]
15	G2W 001 425	VARISTOR	1	1	1	1	1	1	1	1	NR11	
16	G2W 002 422	FUSE	1	1	1	1	1	1	1	1	F11	T3.15AL250V
17	G2W 001 310	INDOOR COIL THERMISTOR	1	1			1	1			RT12, RT13	
17	G2W 002 310	INDOOR COIL THERMISTOR			1	1				1	RT12, RT13	
18	—	PB-COVER (LEFT)	1	1	1	1	1	1	1	1		[ DY00Y071G01 ]
19	—	PB-BOX(LEFT)	1	1	1	1	1	1	1	1		[ DY25Y070G03 ]
20	T2W EAJ 441	Wi-Fi INTERFACE MAC-577IF2-E	1	1	1	1	1	1	1	1		MAC-577IF2-E
21	—	MOTOR BED	1	1	1	1	1	1	1	1		[ SQ00C974G02 ]
22	T2W EAE 023	MOTOR BAND	1	1	1	1	1	1	1	1		
23	—	WATER COVER	1	1	1	1						[ JQ25Y274G01 ]
23	—	WATER COVER					1	1	1	1		[ JQ25Y273G01 ]
24	G2W 001 300	INDOOR FAN MOTOR	1	1	1	1	1	1	1	1	MF	RC0J30 □□, Includes FAN MOTOR RUBBER MOUNT (2 PCS/SET)
25	T2W EBC 302	LINE FLOW FAN	1	1	1	1	1	1	1	1		
26	G2W 001 325	INTER LOCK SWICTH					1	1	1	1		
27	—	SW ARM					1	1	1	1		[ DY25J070G03 ]
②8	—	LEAD WIRE	1	1	1	1	1	1	1	1		[ SM00G912G02 ], Between CN151 on ELECTRONIC CONTROL P.C. BOARD and VANE MOTOR

## 1-5. AIR PURIFYING DEVICE

### Every 3 months:

- Remove dirt by a vacuum cleaner.

### When dirt cannot be removed by vacuum cleaning:

- Soak the filter together with its frame in lukewarm water and rinse it.
- After washing, dry it well in shade.

**NOTE 1:** Clean the filters regularly for best performance and to reduce power consumption.

**NOTE 2:** Dirty filters cause condensation in the air conditioner which will contribute to the growth of fungi such as mold. It is therefore recommended to clean air filters every 2 weeks.

**NOTE 3:** The air purifying device does not function for safety for a couple minutes after the operation starts or the front panel is opened/closed.

**NOTE 4:** Do not disassemble the air purifying device.

**NOTE 5:** Do not touch any parts other than the frame of the air purifying device.

Model
MSZ-AY25VGKP - E6
MSZ-AY35VGKP - E6
MSZ-AY42VGKP - E6
MSZ-AY50VGKP - E6

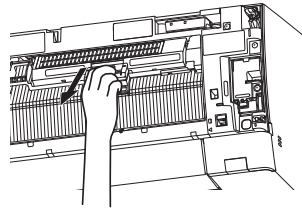

## 1-6. AIR CLEANING FILTER (V BLOCKING FILTER)

### Every 3 months:

- Remove dirt by a vacuum cleaner.

### When dirt cannot be removed by vacuum cleaning:

- Soak the filter and its frame in lukewarm water before rinsing it.
- After washing, dry it well in shade. Install all tabs of the air filter.

### Every year:

- Replace it with a new air cleaning filter for best performance.

**NOTE 1:** Clean the filters regularly for best performance and to reduce power consumption.

**NOTE 2:** Dirty filters cause condensation in the air conditioner which will contribute to the growth of fungi such as mold. It is therefore recommended to clean air filters every 2 weeks.

Model	Part No.
MSZ-AY25VGK - E6	MAC-2470FT-E
MSZ-AY35VGK - E6	
MSZ-AY42VGK - E6	
MSZ-AY50VGK - E6	

Pull to remove from the air filter

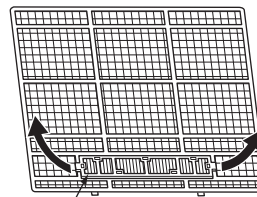

Air cleaning filter

## 2-1. AIR CLEANING FILTER (V BLOCKING FILTER)

Every 3 months:

- Remove dirt by a vacuum cleaner.

**When dirt cannot be removed by vacuum cleaning:**

- Soak the filter and its frame in lukewarm water before rinsing it.
- After washing, dry it well in shade. Install all tabs of the air filter.

Every year:

- Replace it with a new air cleaning filter for best performance.

**NOTE 1:** Clean the filters regularly for best performance and to reduce power consumption.

**NOTE 2:** Dirty filters cause condensation in the air conditioner which will contribute to the growth of fungi such as mold. It is therefore recommended to clean air filters every 2 weeks.

Model	Part No.
MSZ-AY25VGKP - E6	MAC-2470FT-E
MSZ-AY35VGKP - E6	
MSZ-AY42VGKP - E6	
MSZ-AY50VGKP - E6	

Pull to remove from the air filter

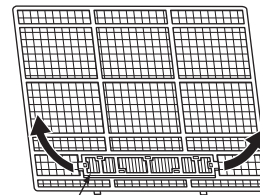

Air cleaning filter

# **mitsubishi electric corporation**

HEAD OFFICE: TOKYO BUILDING, 2-7-3, MARUNOUCHI, CHIYODA-KU, TOKYO 100-8310, JAPAN

© Copyright 2022 MITSUBISHI ELECTRIC CORPORATION

Issued: Nov. 2023. No. OBB930 REVISED EDITION-A

Published: Nov. 2022. No. OBB930

Made in Japan

Specifications are subject to change without notice.