

INDOOR UNIT

No. OBB894
REVISED EDITION-A

PARTS CATALOG

Models

MFZ-KW25VG - [E1], [E2]
MFZ-KW35VG - [E1], [E2]
MFZ-KW50VG - [E1], [E2]
MFZ-KW60VG - [E1], [E2]

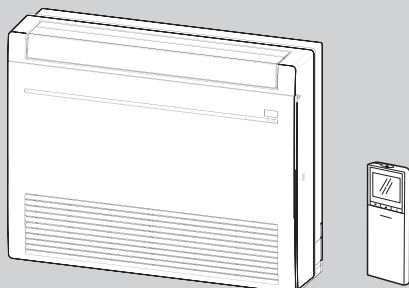

MFZ-KW25VG
MFZ-KW35VG
MFZ-KW50VG
MFZ-KW60VG

CONTENTS

| | |
|-----------------------------|----|
| 1. SERVICE PARTS LIST | 2 |
| 2. OPTIONAL PARTS | 10 |

SERVICE MANUAL (OBH894)

Revision A:

• MFZ-KW25/35/50/60VG-**E2** have been added.

1

SERVICE PARTS LIST

MFZ-KW25VG-E1** MFZ-KW35VG-**E1** MFZ-KW50VG-**E1** MFZ-KW60VG-**E1****

1-1. INDOOR UNIT STRUCTURAL PARTS, HEAT EXCHANGER AND FUNCTIONAL PARTS

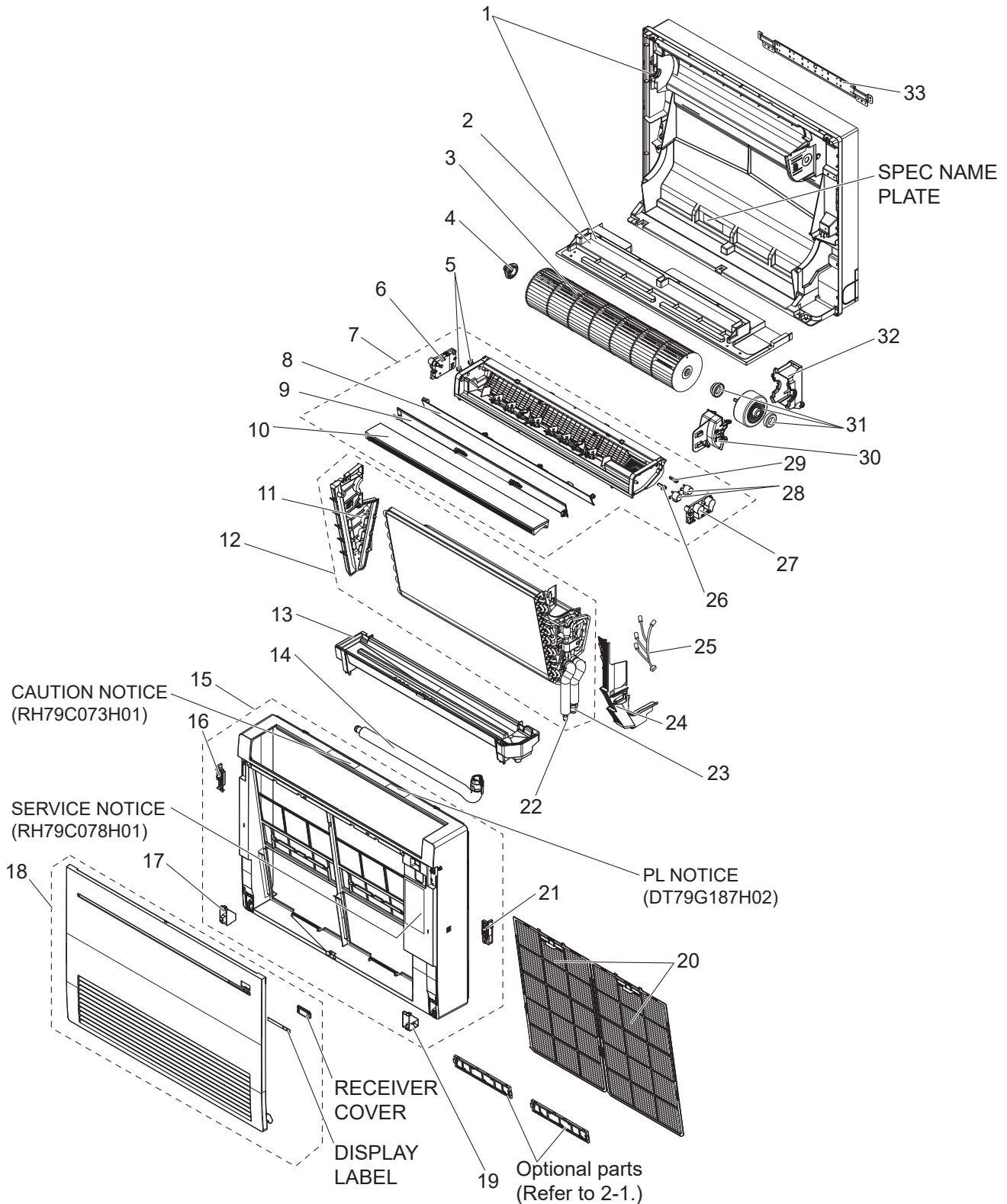

1-1. INDOOR UNIT STRUCTURAL PARTS, HEAT EXCHANGER AND FUNCTIONAL PARTS

1. The part quantity below indicates the required number of pieces per unit.

2. The circled No. indicates that the part is not shown in the figure.

| No. | Part No. | Part Name | MFZ-KW25VG - [ET] | | | | Symbol in Wiring Diagram | Remarks [Drawing No.] |
|-----|-------------|----------------------------|-------------------|-------------------|-------------------|-------------------|--------------------------------|---|
| | | | MFZ-KW25VG - [ET] | MFZ-KW35VG - [ET] | MFZ-KW50VG - [ET] | MFZ-KW60VG - [ET] | | |
| 1 | M21 EBY 234 | BOX ASSEMBLY | 1 | 1 | 1 | 1 | | Includes base without spec name plate |
| 2 | — | BASE | 1 | 1 | 1 | 1 | | [SQ25A544G07] |
| 3 | M21 EAA 302 | LINE FLOW FAN ASSEMBLY | 1 | 1 | 1 | 1 | | |
| 4 | M21 EA3 509 | BEARING ASSEMBLY | 1 | 1 | 1 | 1 | | |
| 5 | M21 EA5 071 | VANE SLEEVE | 2 | 2 | 2 | 2 | | |
| 6 | M21 EA4 306 | MULTI-FLOW VANE MOTOR UNIT | 1 | 1 | 1 | 1 | MV3 | |
| 7 | M21 EAY 235 | NOZZLE ASSEMBLY | 1 | 1 | 1 | 1 | | |
| 8 | M21 EAA 040 | HORIZONTAL VANE (BACK) | 1 | 1 | 1 | 1 | | |
| 9 | M21 EA9 040 | HORIZONTAL VANE (FRONT) | 1 | 1 | 1 | 1 | | |
| 10 | M21 EA8 040 | MULTI-FLOW VANE | 1 | 1 | 1 | 1 | | |
| 11 | — | HAIRPIN HOLDER ASSEMBLY | 1 | 1 | 1 | 1 | | [DQ00T279G05] |
| 12 | M21 ELS 620 | INDOOR HEAT EXCHANGER | 1 | 1 | | | | |
| 12 | M21 ELT 620 | INDOOR HEAT EXCHANGER | | | 1 | 1 | | |
| 13 | M21 EA5 700 | DRAIN PAN ASSEMBLY | 1 | 1 | 1 | 1 | | |
| 14 | M21 7K1 703 | DRAIN HOSE ASSEMBLY | 1 | 1 | 1 | 1 | | |
| 15 | T2W EC2 000 | PANEL ASSEMBLY | 1 | 1 | 1 | 1 | | Includes notice |
| 16 | M21 EA0 099 | HOOK (LEFT) ASSEMBLY | 1 | 1 | 1 | 1 | | |
| 17 | M21 EA8 039 | ARM HOLDER (LEFT) | 1 | 1 | 1 | 1 | | |
| 18 | M21 EBR 010 | FRONT PANEL | 1 | 1 | 1 | 1 | | Includes receiver cover and display label |
| 19 | M21 EA9 039 | ARM HOLDER (RIGHT) | 1 | 1 | 1 | 1 | | |
| 20 | M21 EAS 100 | AIR PURIFYING FILTER | 2 | 2 | 2 | 2 | | |
| 21 | M21 EA1 099 | HOOK (RIGHT) ASSEMBLY | 1 | 1 | 1 | 1 | | |
| 22 | M21 L3V 664 | UNION (LIQ) | 1 | 1 | 1 | 1 | | ø6.35 |
| 23 | M21 L3V 663 | UNION (GAS) | 1 | 1 | | | | ø9.52 |
| 23 | M21 L5V 663 | UNION (GAS) | | | 1 | 1 | | ø12.7 |
| 24 | — | WATER COVER | 1 | 1 | 1 | 1 | | [DQ00T288G04] |
| 25 | M21 EC6 305 | INDOOR COIL THERMISTOR | 1 | 1 | 1 | 1 | RT12, RT13 | |
| 26 | M21 EA5 049 | VANE MOTOR SHAFT (FRONT) | 1 | 1 | 1 | 1 | | |
| 27 | M21 EA1 506 | VANE MOTOR SUPPORT | 1 | 1 | 1 | 1 | | |
| 28 | M21 EA5 306 | VANE MOTOR | 2 | 2 | 2 | 2 | MV1, MV2 | |
| 29 | M21 EA6 049 | VANE MOTOR SHAFT (BACK) | 1 | 1 | 1 | 1 | | |
| 30 | M21 EA3 023 | MOTOR BAND | 1 | 1 | 1 | 1 | | |
| 31 | M21 EDD 300 | INDOOR FAN MOTOR ASSEMBLY | 1 | 1 | | | MF | RC0J30-□□ |
| 31 | M21 EAM 300 | INDOOR FAN MOTOR ASSEMBLY | | | 1 | 1 | MF | RC0J40-□□ |
| 32 | M21 EA3 791 | MOTOR BED | 1 | 1 | 1 | 1 | | |
| 33 | T2W L3V 233 | BACK PLATE | 1 | 1 | 1 | 1 | | |
| ③④ | — | LEAD WIRE ASSEMBLY | 1 | 1 | 1 | 1 | | [DY00C344G04] To terminal block |
| ③⑤ | — | LEAD WIRE ASSEMBLY | 1 | 1 | 1 | 1 | | [DY00C346G03] To vane motor |
| ③⑥ | — | LEAD WIRE ASSEMBLY | 1 | 1 | 1 | 1 | | [DY00C345G03] To display receiver P.C. board |
| ③⑦ | — | LEAD WIRE ASSEMBLY | 1 | 1 | 1 | 1 | | [RH78C059G01] To R32 sensor |

MFZ-KW25VG - E1 MFZ-KW35VG - E1 MFZ-KW50VG - E1 MFZ-KW60VG - E1
1-2. INDOOR UNIT ELECTRICAL PARTS

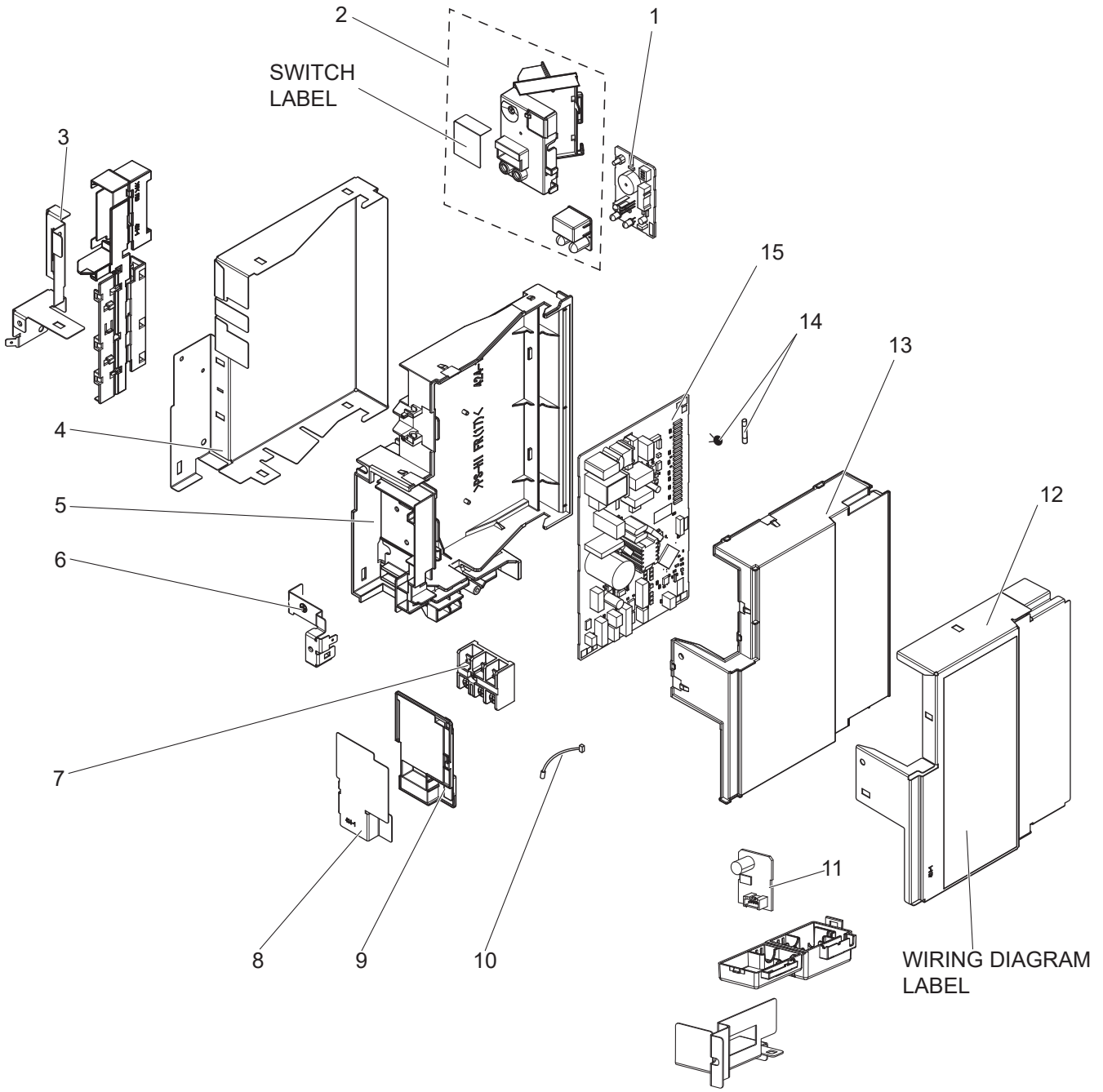

1-3. ACCESSORY AND REMOTE CONTROLLER

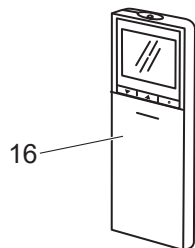

1-2. INDOOR UNIT ELECTRICAL PARTS

1. The part quantity below indicates the required number of pieces per unit.

| No. | Part No. | Part Name | MFZ-KW25VG - [E1] | MFZ-KW35VG - [E1] | MFZ-KW50VG - [E1] | MFZ-KW60VG - [E1] | Symbol in Wiring Diagram | Remarks [Drawing No.] |
|-----|-------------|--------------------------------------|-------------------|-------------------|-------------------|-------------------|--------------------------|---|
| 1 | T2W EBE 328 | DISPLAY RECEIVER P.C. BOARD ASSEMBLY | 1 | 1 | 1 | 1 | | |
| 2 | T2W EAL 012 | SWITCH HOLDER SET | 1 | 1 | 1 | 1 | | Includes switch label |
| 3 | — | TB COVER | 1 | 1 | 1 | 1 | | [DY02B654G01] |
| 4 | — | PB COVER LEFT | 1 | 1 | 1 | 1 | | [DY02A632G03] |
| 5 | — | PB BOX | 1 | 1 | 1 | 1 | | [DY25A631G06] |
| 6 | — | EARTH PLATE | 1 | 1 | 1 | 1 | | [DY02B655G02] |
| 7 | M21 EA3 376 | TERMINAL BLOCK | 1 | 1 | 1 | 1 | TB | |
| 8 | — | VA CLAMP COVER | 1 | 1 | 1 | 1 | | [DK02B679G02] |
| 9 | — | VA CLAMP | 1 | 1 | 1 | 1 | | [DK25B680G03] |
| 10 | M21 EAA 305 | ROOM TEMPERATURE THERMISTOR | 1 | 1 | 1 | 1 | RT11 | |
| 11 | M21 EA1 334 | R32 SENSOR | 1 | 1 | 1 | 1 | | |
| 12 | — | PB COVER RIGHT | 1 | 1 | 1 | 1 | | [DK02A696G01] Without wiring diagram label |
| 13 | — | PB COVER | 1 | 1 | 1 | 1 | | [DK25A695G01] |
| 14 | M21 EA5 313 | FUSE VARISTOR SET | 1 | 1 | 1 | 1 | F11/ NR11 | T3.15AL250V |
| 15 | T2W FE6 450 | ELECTRONIC CONTROL P.C. BOARD | 1 | | | | | |
| 15 | T2W FE7 450 | ELECTRONIC CONTROL P.C. BOARD | | 1 | | | | |
| 15 | T2W FE8 450 | ELECTRONIC CONTROL P.C. BOARD | | | 1 | | | |
| 15 | T2W FE9 450 | ELECTRONIC CONTROL P.C. BOARD | | | | 1 | | |

1-3. ACCESSORY AND REMOTE CONTROLLER

1. The part quantity below indicates the required number of pieces per unit.

| No. | Part No. | Part Name | MFZ-KW25VG - [E1] | MFZ-KW35VG - [E1] | MFZ-KW50VG - [E1] | MFZ-KW60VG - [E1] | Symbol in Wiring Diagram | Remarks |
|-----|-------------|----------------------------|-------------------|-------------------|-------------------|-------------------|--------------------------|---------|
| 16 | T2W EGA 426 | REMOTE CONTROLLER ASSEMBLY | 1 | 1 | 1 | 1 | | SG191 |

MFZ-KW25VG - E2 MFZ-KW35VG - E2 MFZ-KW50VG - E2 MFZ-KW60VG - E2

1-4. INDOOR UNIT STRUCTURAL PARTS, HEAT EXCHANGER AND FUNCTIONAL PARTS

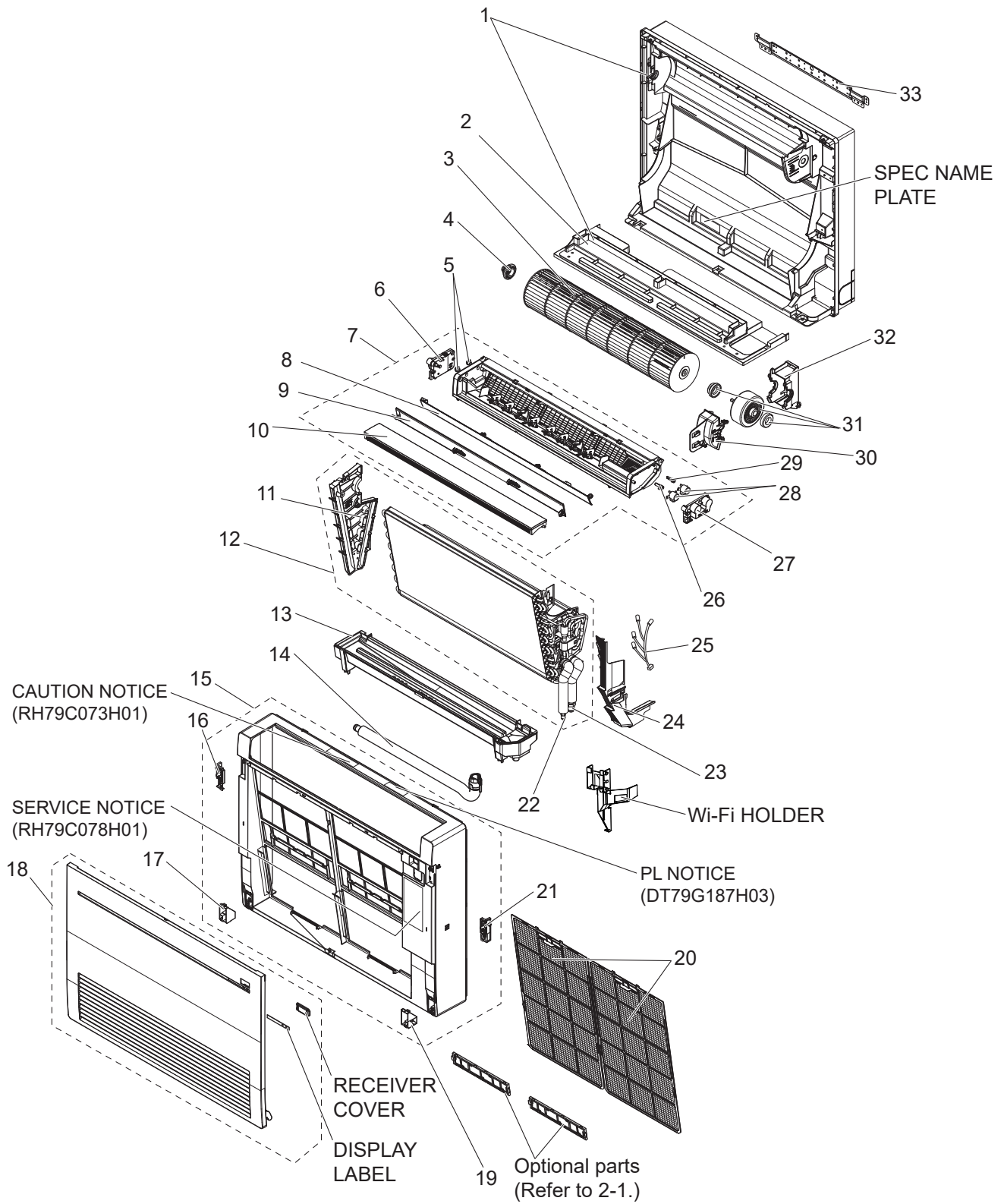

1-4. INDOOR UNIT STRUCTURAL PARTS, HEAT EXCHANGER AND FUNCTIONAL PARTS

1. The part quantity below indicates the required number of pieces per unit.

2. The circled No. indicates that the part is not shown in the figure.

| No. | Part No. | Part Name | MFZ-KW25VG | MFZ-KW35VG | MFZ-KW50VG | MFZ-KW60VG | Symbol in Wiring Diagram | Remarks [Drawing No.] |
|-----|-------------|----------------------------|------------|------------|------------|------------|--------------------------------|---|
| | | | E2 | E2 | E2 | E2 | | |
| 1 | M21 EBY 234 | BOX ASSEMBLY | 1 | 1 | 1 | 1 | | Includes base without spec name plate |
| 2 | — | BASE | 1 | 1 | 1 | 1 | | [SQ25A544G07] |
| 3 | M21 EAA 302 | LINE FLOW FAN ASSEMBLY | 1 | 1 | 1 | 1 | | |
| 4 | M21 EA3 509 | BEARING ASSEMBLY | 1 | 1 | 1 | 1 | | |
| 5 | M21 EA5 071 | VANE SLEEVE | 2 | 2 | 2 | 2 | | |
| 6 | M21 EA4 306 | MULTI-FLOW VANE MOTOR UNIT | 1 | 1 | 1 | 1 | MV3 | |
| 7 | M21 EAY 235 | NOZZLE ASSEMBLY | 1 | 1 | 1 | 1 | | |
| 8 | M21 EAA 040 | HORIZONTAL VANE (BACK) | 1 | 1 | 1 | 1 | | |
| 9 | M21 EA9 040 | HORIZONTAL VANE (FRONT) | 1 | 1 | 1 | 1 | | |
| 10 | M21 EA8 040 | MULTI-FLOW VANE | 1 | 1 | 1 | 1 | | |
| 11 | — | HAIRPIN HOLDER ASSEMBLY | 1 | 1 | 1 | 1 | | [DQ00T279G05] |
| 12 | M21 ELS 620 | INDOOR HEAT EXCHANGER | 1 | 1 | | | | |
| 12 | M21 ELT 620 | INDOOR HEAT EXCHANGER | | | 1 | 1 | | |
| 13 | M21 EA5 700 | DRAIN PAN ASSEMBLY | 1 | 1 | 1 | 1 | | |
| 14 | M21 7K1 703 | DRAIN HOSE ASSEMBLY | 1 | 1 | 1 | 1 | | |
| 15 | T2W EC2 000 | PANEL ASSEMBLY | 1 | 1 | 1 | 1 | | Includes notice |
| 16 | M21 EA0 099 | HOOK (LEFT) ASSEMBLY | 1 | 1 | 1 | 1 | | |
| 17 | M21 EA8 039 | ARM HOLDER (LEFT) | 1 | 1 | 1 | 1 | | |
| 18 | M21 EBR 010 | FRONT PANEL | 1 | 1 | 1 | 1 | | Includes receiver cover and display label |
| 19 | M21 EA9 039 | ARM HOLDER (RIGHT) | 1 | 1 | 1 | 1 | | |
| 20 | M21 EAS 100 | AIR PURIFYING FILTER | 2 | 2 | 2 | 2 | | |
| 21 | M21 EA1 099 | HOOK (RIGHT) ASSEMBLY | 1 | 1 | 1 | 1 | | |
| 22 | M21 L3V 664 | UNION (LIQ) | 1 | 1 | 1 | 1 | | ø6.35 |
| 23 | M21 L3V 663 | UNION (GAS) | 1 | 1 | | | | ø9.52 |
| 23 | M21 L5V 663 | UNION (GAS) | | | 1 | 1 | | ø12.7 |
| 24 | — | WATER COVER | 1 | 1 | 1 | 1 | | [DQ00T288G04] |
| 25 | M21 EC6 305 | INDOOR COIL THERMISTOR | 1 | 1 | 1 | 1 | RT12, RT13 | |
| 26 | M21 EA5 049 | VANE MOTOR SHAFT (FRONT) | 1 | 1 | 1 | 1 | | |
| 27 | M21 EA1 506 | VANE MOTOR SUPPORT | 1 | 1 | 1 | 1 | | |
| 28 | M21 EA5 306 | VANE MOTOR | 2 | 2 | 2 | 2 | MV1, MV2 | |
| 29 | M21 EA6 049 | VANE MOTOR SHAFT (BACK) | 1 | 1 | 1 | 1 | | |
| 30 | M21 EA3 023 | MOTOR BAND | 1 | 1 | 1 | 1 | | |
| 31 | T2W EFE 300 | INDOOR FAN MOTOR ASSEMBLY | 1 | 1 | | | MF | RC0J30-□□ |
| 31 | M21 EAM 300 | INDOOR FAN MOTOR ASSEMBLY | | | 1 | 1 | MF | RC0J40-□□ |
| 32 | M21 EA3 791 | MOTOR BED | 1 | 1 | 1 | 1 | | |
| 33 | T2W L3V 233 | BACK PLATE | 1 | 1 | 1 | 1 | | |
| ③④ | — | LEAD WIRE ASSEMBLY | 1 | 1 | 1 | 1 | | [DY00C344G04] To terminal block |
| ③⑤ | — | LEAD WIRE ASSEMBLY | 1 | 1 | 1 | 1 | | [DY00C346G03] To vane motor |
| ③⑥ | — | LEAD WIRE ASSEMBLY | 1 | 1 | 1 | 1 | | [DY00C345G03] To display receiver P.C. board |
| ③⑦ | — | LEAD WIRE ASSEMBLY | 1 | 1 | 1 | 1 | | [RH78C059G01] To R32 sensor |

MFZ-KW25VG - E2 MFZ-KW35VG - E2 MFZ-KW50VG - E2 MFZ-KW60VG - E2
1-5. INDOOR UNIT ELECTRICAL PARTS

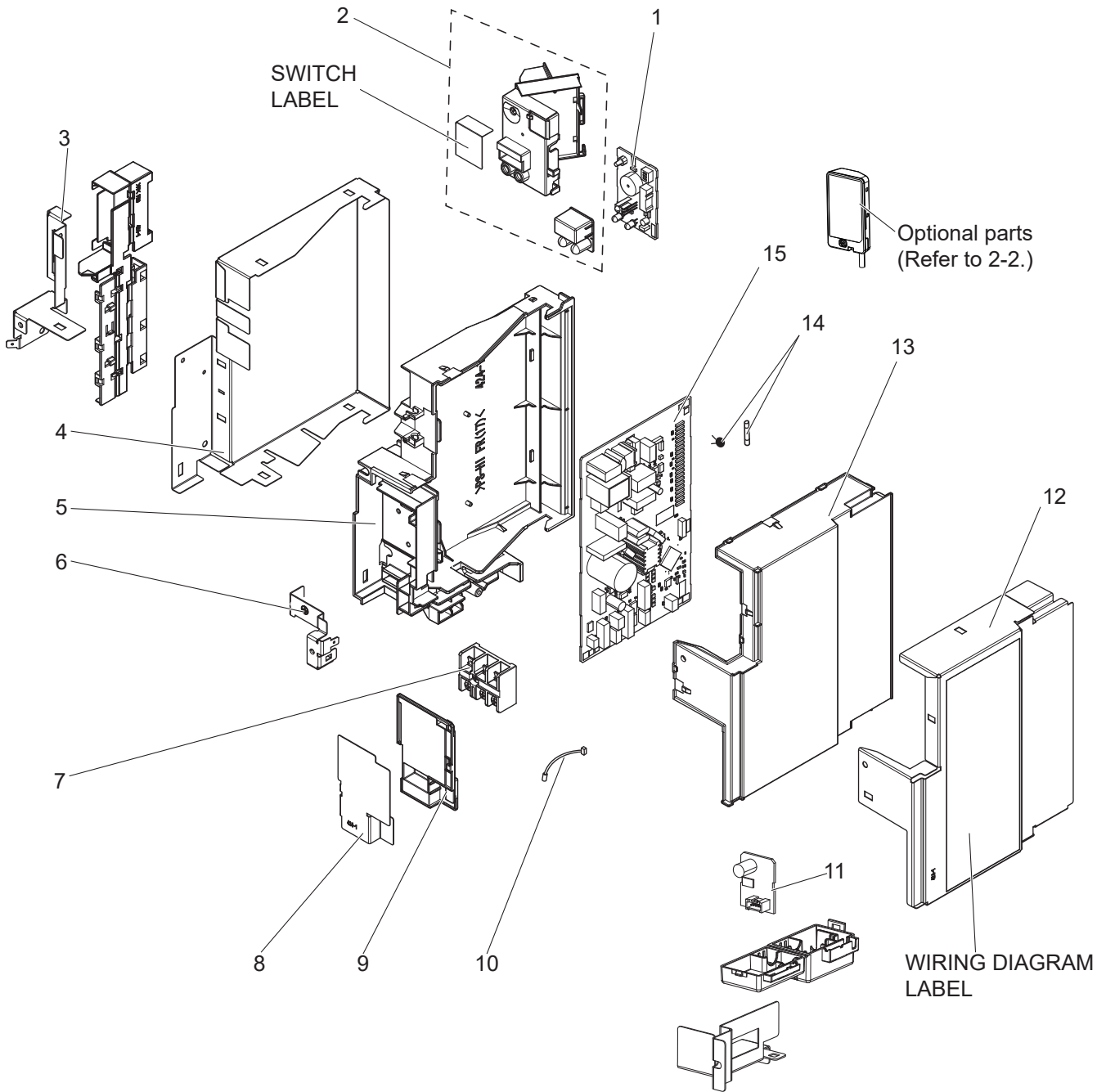

1-6. ACCESSORY AND REMOTE CONTROLLER

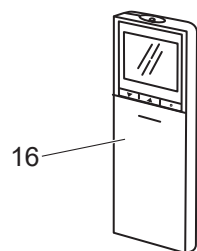

1-5. INDOOR UNIT ELECTRICAL PARTS

1. The part quantity below indicates the required number of pieces per unit.

| No. | Part No. | Part Name | MFZ-KW25VG - E2 | MFZ-KW35VG - E2 | MFZ-KW50VG - E2 | MFZ-KW60VG - E2 | Symbol in Wiring Diagram | Remarks [Drawing No.] |
|-----|-------------|--------------------------------------|-----------------|-----------------|-----------------|-----------------|--------------------------|---|
| 1 | T2W EBE 328 | DISPLAY RECEIVER P.C. BOARD ASSEMBLY | 1 | 1 | 1 | 1 | | |
| 2 | T2W EAR 012 | SWITCH HOLDER SET | 1 | 1 | 1 | 1 | | Includes switch label |
| 3 | — | TB COVER | 1 | 1 | 1 | 1 | | [DY02B654G01] |
| 4 | — | PB COVER LEFT | 1 | 1 | 1 | 1 | | [DY02A632G03] |
| 5 | — | PB BOX | 1 | 1 | 1 | 1 | | [DY25A631G06] |
| 6 | — | EARTH PLATE | 1 | 1 | 1 | 1 | | [DY02B655G02] |
| 7 | M21 EA3 376 | TERMINAL BLOCK | 1 | 1 | 1 | 1 | TB | |
| 8 | — | VA CLAMP COVER | 1 | 1 | 1 | 1 | | [DK02B679G02] |
| 9 | — | VA CLAMP | 1 | 1 | 1 | 1 | | [DK25B680G03] |
| 10 | M21 EAA 305 | ROOM TEMPERATURE THERMISTOR | 1 | 1 | 1 | 1 | RT11 | |
| 11 | M21 EA2 334 | R32 SENSOR | 1 | 1 | 1 | 1 | | |
| 12 | — | PB COVER RIGHT | 1 | 1 | 1 | 1 | | [DK02A696G01] Without wiring diagram label |
| 13 | — | PB COVER | 1 | 1 | 1 | 1 | | [DK25A695G01] |
| 14 | M21 EA5 313 | FUSE VARISTOR SET | 1 | 1 | 1 | 1 | F11/ NR11 | T3.15AL250V |
| 15 | T2W FE6 450 | ELECTRONIC CONTROL P.C. BOARD | 1 | | | | | |
| 15 | T2W FE7 450 | ELECTRONIC CONTROL P.C. BOARD | | 1 | | | | |
| 15 | T2W FE8 450 | ELECTRONIC CONTROL P.C. BOARD | | | 1 | | | |
| 15 | T2W FE9 450 | ELECTRONIC CONTROL P.C. BOARD | | | | 1 | | |

1-6. ACCESSORY AND REMOTE CONTROLLER

1. The part quantity below indicates the required number of pieces per unit.

| No. | Part No. | Part Name | MFZ-KW25VG - E2 | MFZ-KW35VG - E2 | MFZ-KW50VG - E2 | MFZ-KW60VG - E2 | Symbol in Wiring Diagram | Remarks |
|-----|-------------|----------------------------|-----------------|-----------------|-----------------|-----------------|--------------------------|---------|
| 16 | T2W EHJ 426 | REMOTE CONTROLLER ASSEMBLY | 1 | 1 | 1 | 1 | | SH24G |

2-1. AIR CLEANING FILTER

1. SILVER-IONIZED AIR PURIFIER FILTER

| Model | Part No. |
|--|--------------|
| MFZ-KW25VG MFZ-KW35VG MFZ-KW50VG MFZ-KW60VG | MAC-2370FT-E |

2. V BLOCKING FILTER

| Model | Part No. |
|--|--------------|
| MFZ-KW25VG MFZ-KW35VG MFZ-KW50VG MFZ-KW60VG | MAC-2470FT-E |

Every 3 months:

- Remove dirt by a vacuum cleaner.

When dirt cannot be removed by vacuum cleaning:

- Soak the filter and its frame in lukewarm water before rinsing it.
(Diluted mild detergents can be used when dirt cannot be removed.)
- After washing, dry it well in shade.

Every year:

- Replace it with a new air cleaning filter for best performance.

Replacement of the air cleaning filter

(1) Remove the front panel.

1. Push down the tab on the both sides of the unit to open the front panel.
2. Pull the front panel toward you to remove it.
3. Open the front panel completely and remove it.

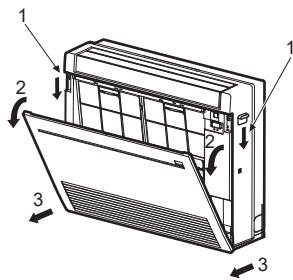

(3) Replace the air cleaning filter.

Fix the filter with the tabs securely.

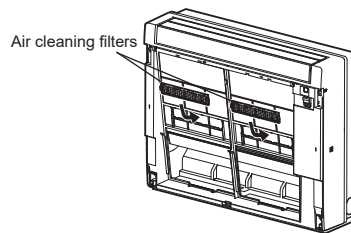

(2) Remove the air filter.

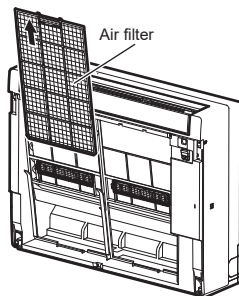

(4) Install the air filter.

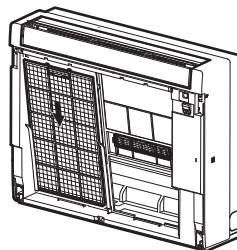

(5) Securely close the front panel.

Install the front panel by the removal procedure in reverse. Refer to (1) 1-3.

2-2. Wi-Fi INTERFACE

| Model | Part No. |
|-----------------|-------------|
| MFZ-KW25VG - E2 | MAC-587IF-E |
| MFZ-KW35VG - E2 | |
| MFZ-KW50VG - E2 | |
| MFZ-KW60VG - E2 | |

How to install

When connecting the Wi-Fi interface (option) Install the interface in the holder as shown in the figure. Adjust the length of the cable, and bundle it as shown in the figure.

- (1) Remove the panel.
- (2) Open the cover of the indoor control P.C. board.
- (3) Joint the connecting cable to CN105 on the indoor control P.C. board.
- (4) Route the connecting cable through this point in the figure.
- (5) Attach the cable clamp provided with interface/connector cable to the thick part of the connecting cable with a screw 4 × 16 as shown in the figure.
- (6) Set the Wi-Fi interface in the holder.
- (7) Set the connecting cable in the holder, then fix it with the band (L).
- (8) Bundle the excess cable with the band (L). The rolled part should be about 140 mm.
- (9) Close the cover of the indoor control P.C. board. Be careful not to catch the thin part of the connecting cable in the cover. Reinstall the panel.

⚠ WARNING

Fix the connecting cable at the prescribed position securely. Incorrect installation may cause electric shock, fire, and/or malfunction.

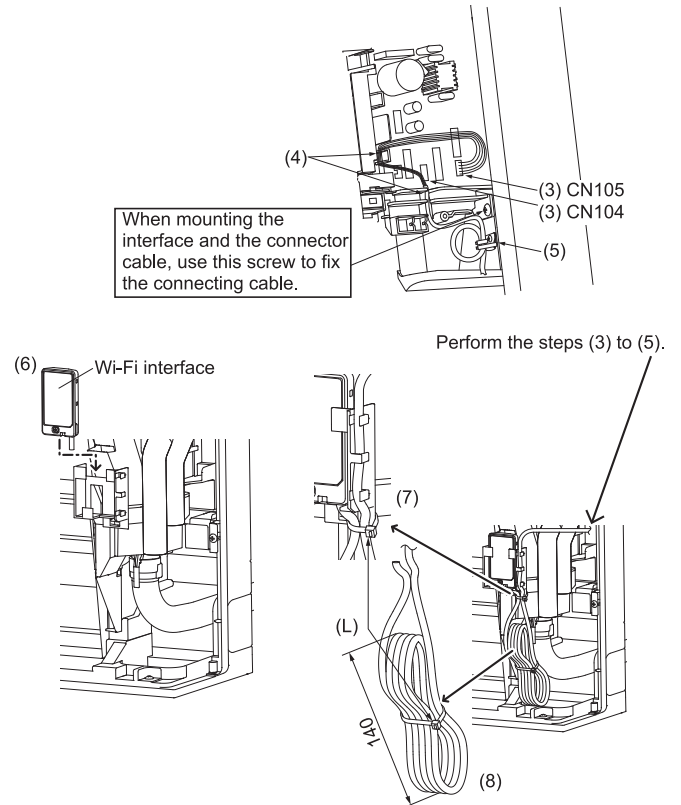

mitsubishi electric corporation

HEAD OFFICE: TOKYO BUILDING, 2-7-3, MARUNOUCHI, CHIYODA-KU, TOKYO 100-8310, JAPAN

© Copyright 2021 MITSUBISHI ELECTRIC CORPORATION

Issued: Apr. 2024. No. OBB894 REVISED EDITION-A

Published: Jul. 2021. No. OBB894

Made in Japan

Specifications are subject to change without notice.