

Descriptions

A-control Mr. SLIM models can be connected to "M-NET" through optional M-NET converter so that they can be monitored / controlled effectively and meticulously.

Applicable Models

- PUZ-ZM35VKA2
- PUZ-ZM50VKA2

Specifications

Power	Supplied from control board
Power consumption	0.6W (at 5V DC, 12V DC)
Operating conditions	Mounted inside the electrical utility box. (Temperature: -20 to 60°C , humidity: 90% or less (no condensation))
Weight	0.68kg (without package)

Dimensions

Unit: mm

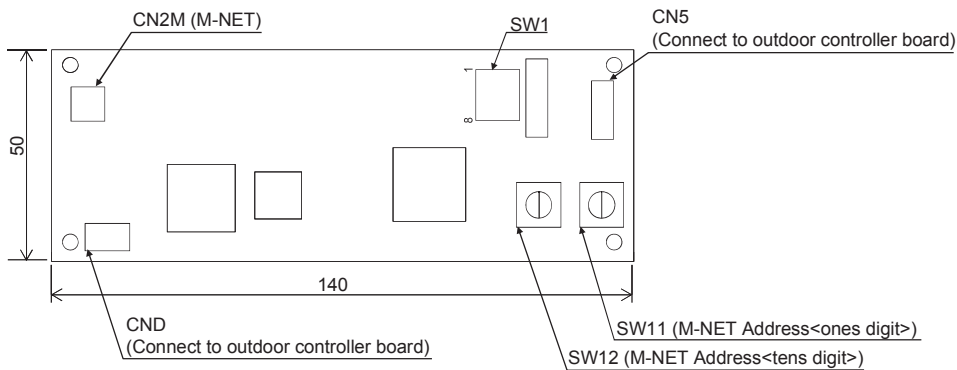

How to Use / How to Install

1. Wiring diagram



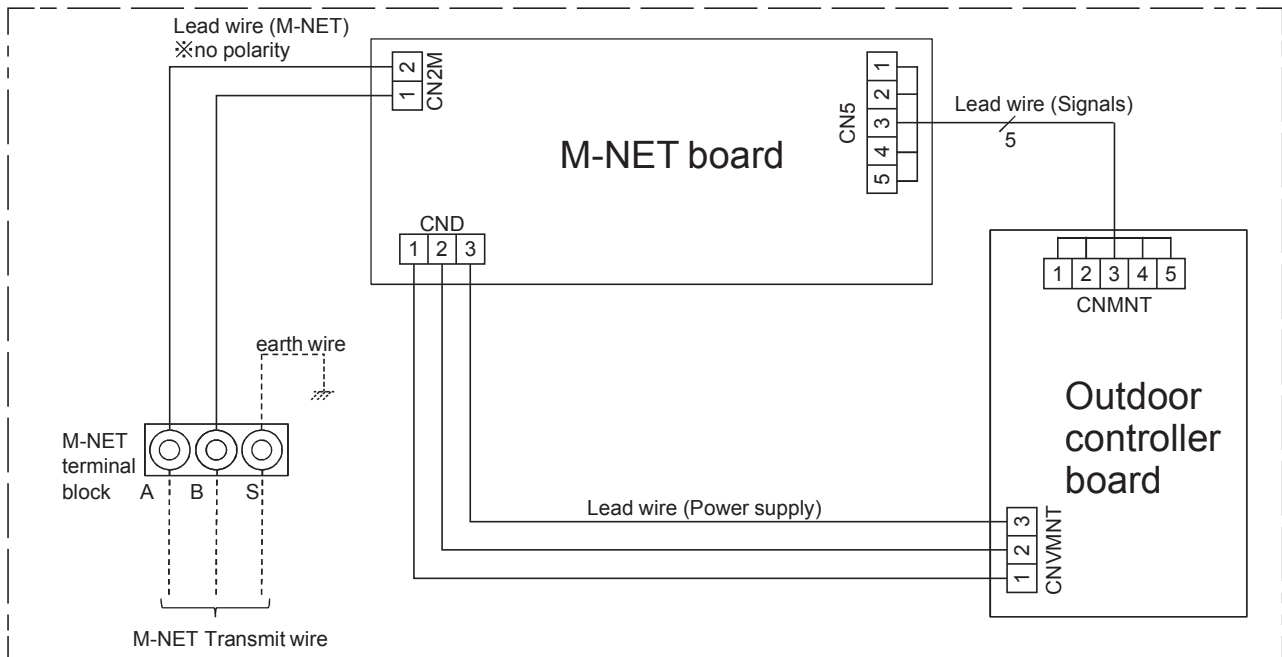





The electrical box of outdoor unit.

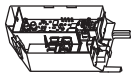
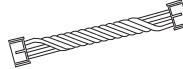

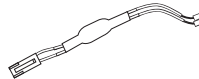
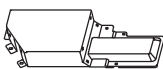
OPTIONAL PARTS

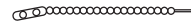
OUTDOOR UNIT

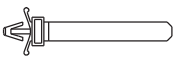
2. Parts List

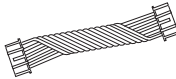
No.	Part name	Figure	Q'ty	No.	Part name	Figure	Q'ty
①	M-NET case (bottom) (with M-NET board, M-NET terminal block, and cable bushing)		1	⑧	Lead wire for power supply (3 poles)		1
②	M-NET case (top)		1	⑨	Lead wire for M-NET (2 poles)		1
③	M-NET cover		1	⑩	Earth wire and screw (M4×8)		1 each
④	Screw (M4×10) (not serrated)		2	⑪	Fastener		1
⑤	Screw (M4×10) (serrated)		4	⑫	Cable tie		1
⑥	Cable band		1	⑬	White cushioning material		1
⑦	Lead wire for signal (5 poles)		1				

3. Switch setting

■ M-NET address setting

Make M-NET setting and refrigerant address setting on only outdoor unit.

There is no address settings for outdoor unit and remote controller like City Multi system.







The M-NET address setting for taking into centralized control system should be done only to the outdoor unit.

The address set number should be 1-50 same as for City Multi indoor unit and make set in order of number for the same group.

	A control slim	City Multi (M-NET)
Indoor unit	—	1 - 50
Outdoor unit	1 - 50	51 - 100
Remote controller	—	101 - 150
System controller	201 - 250	
Group remote controller	201 - 250	

The setting should be done by rotary switches SW11 (ones digit) and SW12 (tens digit) on M-NET board of the outdoor unit. (Factory settings are all zero.)

[Example]

M-NET address No.		1	2	50
Switch setting	SW11 (ones digit)			
	SW12 (tens digit)			

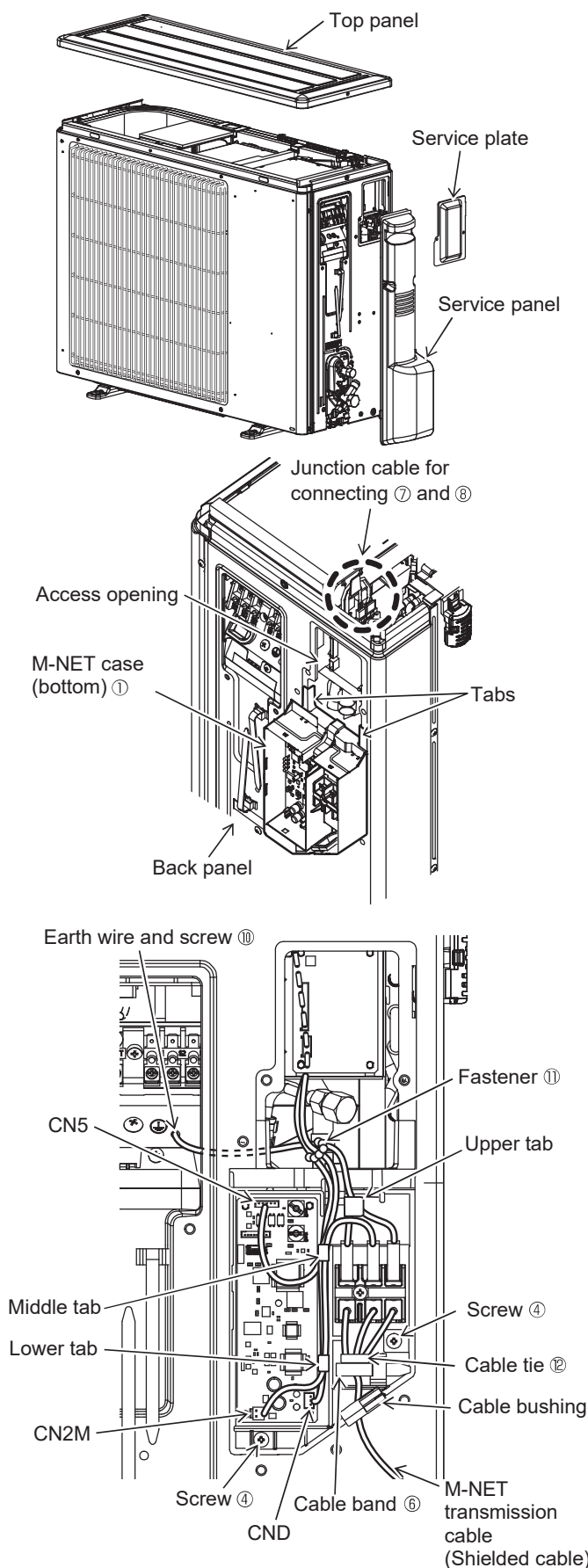
4. Work procedure

- (1) Remove the top panel, service panel, and service plate.
 - The 2 screws removed from the service plate will be used in (14).
 - The removed service plate will not be used.

- (2) Attach the 2 tabs of the M-NET case (bottom) ① to the access opening.

- (3) Fix the M-NET case (bottom) ① to the back panel with the 2 screws ④.

- (4) Connect the lead wire for signal (5 poles) ⑦ and the lead wire for power supply (3 poles) ⑧ to the junction cable for connection ⑦ and ⑧ that is fixed on the back of the electrical parts box.
 - When connecting the wires, mate the connectors of the same color.

- (5) Pass the lead wire for signal (5 poles) ⑦ that was connected in (4) through the middle tab of the M-NET case (bottom) ①, and connect it to CN5 on the M-NET board.

- (6) Pass the lead wire for power supply (3 poles) ⑧ that was connected in (4) through the middle and lower tabs of the M-NET case (bottom) ①, and connect it to CND on the M-NET board.

- (7) Connect the lead wire for M-NET (2 poles) ⑨ to CN2M on the M-NET board. Pass it through the middle and lower tabs of the M-NET case (bottom) ①, and connect it to A and B terminals on the M-NET terminal block. There is no polarity.
 - Position the thick portion of black tube of the lead wire for M-NET (2 poles) ⑨ between the middle and the lower tabs.

Note 1: Connect the shield of the M-NET transmission cable to the outdoor terminal block plate with the earth wire and screw ⑩ as needed.
Refer to "(1) Earth wire connection" on page 2.

- (8) Tie the wires routed in (5), (6), and Note1 together with the fastener ⑪.

- (9) Attach the cable band ⑥ to the M-NET transmission cable (shielded cable), and then attach the cable band ⑥ to the M-NET case (bottom) ①.

- (10) Attach the cable tie ⑫ above the cable band ⑥ so that external force on the cables is not transmitted to the terminal connections.
 - Cut off the excess part of the cable tie ⑫.

- (11) Pass the M-NET transmission cable (shielded cable) that was attached to the M-NET case (bottom) ① in (9) through the cable bushing. Seal the intake part of the M-NET transmission cable (shielded cable) with putty or other sealing material you have.
(Failure to do so can cause sound leakage or breakdown due to intrusion of small animals, rainwater, dust, etc.)

Note 2: Route the cables as shown in the left figure.

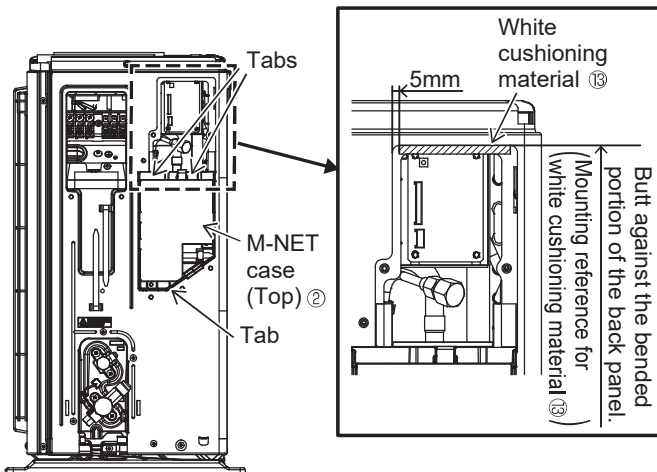

- (12) Attach the M-NET case (top) ② to the M-NET case (bottom) ① using the 3 tabs of the M-NET case (bottom) ①.

Note: Insert the black cushioning material (insulation) attached to the lead wire for signal (5 poles) ⑦, the lead wire for power supply (3 poles) ⑧, and the earth wire ⑩ between the M-NET case (bottom) ① and the M-NET case (top) ②. (Failure to do so can cause breakage due to intrusion of rainwater or oil.)

- (13) Attach the white cushioning material ⑬ to the back panel. (Failure to do so can cause breakage due to intrusion of rainwater or oil.)

Screws removed in (1)

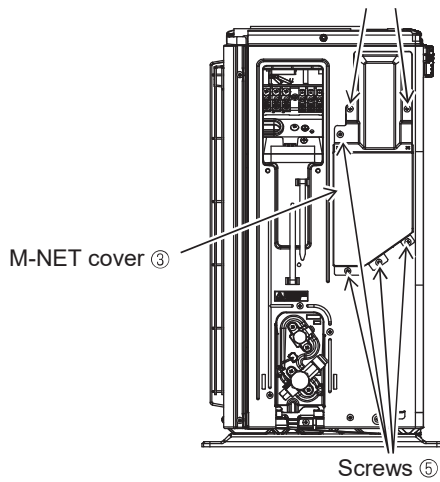

- (14) Fix the M-NET cover ③ to the back panel with the 4 screws ⑤ and the 2 screws removed in (1).

• Be careful not to let the lead wire get caught between them.

- (15) Reinstall the top panel and the service panel.

