

SPLIT-TYPE AIR CONDITIONERS

INDOOR UNIT

No. OBH921

SERVICE MANUAL

Models

MLZ-KY20VG - **E1**, **ET1**

Outdoor unit service manual
MXZ-F•VF Series (OBH790)

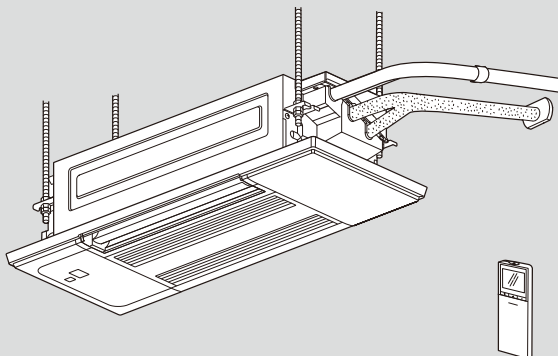

CONTENTS

1. TECHNICAL CHANGES	2
2. SAFETY PRECAUTION.....	3
3. PART NAMES AND FUNCTIONS.....	7
4. SPECIFICATION	8
5. NOISE CRITERIA CURVES	9
6. OUTLINES AND DIMENSIONS.....	10
7. WIRING DIAGRAM.....	11
8. REFRIGERANT SYSTEM DIAGRAM	12
9. SERVICE FUNCTIONS.....	13
10. MICROPROCESSOR CONTROL	16
11. TROUBLESHOOTING	24
12. DISASSEMBLY INSTRUCTIONS	38

PARTS CATALOG (OBB921)

Use the specified refrigerant only

Never use any refrigerant other than that specified.

Doing so may cause a burst, an explosion, or fire when the unit is being used, serviced, or disposed of.

Correct refrigerant is specified in the manuals and on the spec labels provided with our products.

We will not be held responsible for mechanical failure, system malfunction, unit breakdown or accidents caused by failure to follow the instructions.

<Preparation before the repair service>

- Prepare the proper tools.
- Prepare the proper protectors.
- Provide adequate ventilation.
- After stopping the operation of the air conditioner, turn off the power-supply breaker and pull the power plug.
- Discharge the capacitor before the work involving the electric parts.

<Precautions during the repair service>

- Do not perform the work involving the electric parts with wet hands.
- Do not pour water into the electric parts.
- Do not touch the refrigerant.
- Do not touch the hot or cold areas in the refrigeration cycle.
- When the repair or the inspection of the circuit needs to be done without turning off the power, exercise great caution not to touch the live parts.

WARNING

- When the refrigeration circuit has a leak, do not execute pump down with the compressor.
- When pumping down the refrigerant, stop the compressor before disconnecting the refrigerant pipes. The compressor may burst if air etc. get into it.
- When opening or closing the valve below freezing temperatures, refrigerant may spurt out from the gap between the valve stem and the valve body, resulting in injuries.

1

TECHNICAL CHANGES

MLZ-KY20VG-[E1], [ET1]

1. New model

CAUTIONS RELATED TO NEW REFRIGERANT

Cautions for units utilizing refrigerant R32



WARNING

Warning for service

- (1) In case of reconnecting the refrigerant pipes after detaching, make the flared part of pipe re-fabricated.
- (2) This unit should be installed in rooms which exceed the floor space specified in outdoor unit installation manual. Refer to outdoor unit installation manual.
- (3) Refrigerant pipes connection shall be accessible for maintenance purposes.
- (4) Do not use low temperature solder alloy in case of brazing the refrigerant pipes.
- (5) Do not use means to accelerate the defrosting process or to clean, other than those recommended by the manufacturer.
- (6) The appliance shall be stored in a room without continuously operating ignition sources (for example: open flames, an operating gas appliance or an operating electric heater).
- (7) Do not pierce or burn.
- (8) Be aware that refrigerants may not contain an odour.
- (9) Pipe-work shall be protected from physical damage.
- (10) The installation of pipe-work shall be kept to a minimum.
- (11) Compliance with national gas regulations shall be observed.
- (12) Keep any required ventilation openings clear of obstruction.
- (13) Servicing shall be performed only as recommended by the manufacturer.
- (14) The appliance shall be stored in a well-ventilated area where the room size corresponds to the room area as specified for operation.
- (15) Maintenance, service and repair operations shall be performed by authorized technician with required qualification.

Cautions for unit using R32 refrigerant

Basic work procedures are the same as those for conventional units using refrigerant R410A. However, pay careful attention to the following points.

1. Information on servicing

(1) Checks on the Area

Prior to beginning work on systems containing flammable refrigerants, safety checks are necessary to ensure that the risk of ignition is minimized.

For repair to the refrigerating systems, (3) to (7) shall be completed prior to conducting work on the systems.

(2) Work Procedure

Work shall be undertaken under a controlled procedure so as to minimize the risk of a flammable gas or vapor being present while the work is being performed.

(3) General Work Area

All maintenance staff and others working in the local area shall be instructed on the nature of work being carried out.

Work in confined spaces shall be avoided. The area around the workspace shall be sectioned off. Ensure that the conditions within the area have been made safe by control of flammable material.

(4) Checking for Presence of Refrigerant

The area shall be checked with an appropriate refrigerant detector prior to and during work, to ensure the technician is aware of potentially toxic or flammable atmospheres. Ensure that the leak detection equipment being used is suitable for use with all applicable refrigerants, i.e. non-sparking, adequately sealed or intrinsically safe.

(5) Presence of Fire Extinguisher

If any hot work is to be conducted on the refrigeration equipment or any associated parts, appropriate fire extinguishing equipment shall be available to hand.

Have a dry powder or CO2 fire extinguisher adjacent to the charging area.

(6) No Ignition Sources

No person carrying out work in relation to a refrigeration system which involves exposing any pipe work shall use any sources of ignition in such a manner that it may lead to the risk of fire or explosion. All possible ignition sources, including cigarette smoking, should be kept sufficiently far away from the site of installation, repairing, removing and disposal, during which refrigerant can possibly be released to the surrounding space. Prior to work taking place, the area around the equipment is to be surveyed to make sure that there are no flammable hazards or ignition risks. "No Smoking" signs shall be displayed.

(7) Ventilated Area

Ensure that the area is in the open or that it is adequately ventilated before breaking into the system or conducting any hot work. A degree of ventilation shall continue during the period that the work is carried out. The ventilation should safely disperse any released refrigerant and preferably expel it externally into the atmosphere.

(8) Checks on the Refrigeration Equipment

Where electrical components are being changed, they shall be fit for the purpose and to the correct specification. At all times the manufacturer's maintenance and service guidelines shall be followed. If in doubt, consult the manufacturer's technical department for assistance.

The following checks shall be applied to installations using flammable refrigerants:

- The charge size is in accordance with the room size within which the refrigerant containing parts are installed.
- The ventilation machinery and outlets are operating adequately and are not obstructed.
- Marking to the equipment continues to be visible and legible. Markings and signs that are illegible shall be corrected.
- Refrigeration pipe or components are installed in a position where they are unlikely to be exposed to any substance which may corrode refrigerant containing components, unless the components are constructed of materials which are inherently resistant to being corroded or are suitably protected against being corroded.

(9) Checks on Electrical Devices

Repair and maintenance to electrical components shall include initial safety checks and component inspection procedures. If a fault exists that could compromise safety, then no electrical supply shall be connected to the circuit until it is satisfactorily dealt with. If the fault cannot be corrected immediately but it is necessary to continue operation, an adequate temporary solution shall be used. This shall be reported to the owner of the equipment so all parties are advised. Initial safety checks shall include that:

- capacitors are discharged: this shall be done in a safe manner to avoid possibility of sparking;
- no live electrical components and wiring are exposed while charging, recovering or purging the system;
- there is continuity of earth bonding

2. Repairs to Sealed Components

(1) During repairs to sealed components, all electrical supplies shall be disconnected from the equipment being worked upon prior to any removal of sealed covers, etc. If it is absolutely necessary to have an electrical supply to equipment during servicing, then a permanently operating form of leak detection shall be located at the most critical point to warn of a potentially hazardous situation.

(2) Particular attention shall be paid to the following to ensure that by working on electrical components, the casing is not altered in such a way that the level of protection is affected. This shall include damage to cables, excessive number of connections, terminals not made to original specification, damage to seals, incorrect fitting of glands, etc.

Ensure that the apparatus is mounted securely.

Ensure that seals or sealing materials have not degraded to the point that they no longer serve the purpose of preventing the ingress of flammable atmospheres.

Replacement parts shall be in accordance with the manufacturer's specifications.

3. Repair to Intrinsically Safe Components

Do not apply any permanent inductive or capacitance loads to the circuit without ensuring that this will not exceed the permissible voltage and current permitted for the equipment in use.

Intrinsically safe components are the only types that can be worked on while live in the presence of a flammable atmosphere. The test apparatus shall be at the correct rating.

Replace components only with parts specified by the manufacturer. Other parts may result in the ignition of refrigerant in the atmosphere from a leak.

4. Cabling

Check that cabling will not be subject to wear, corrosion, excessive pressure, vibration, sharp edges or any other adverse environmental effects. The check shall also take into account the effects of aging or continual vibration from sources such as compressors or fans.

5. Detection of Flammable Refrigerants

Under no circumstances shall potential sources of ignition be used in the searching for or detection of refrigerant leaks. A halide torch (or any other detector using a naked flame) shall not be used.

6. Leak Detection Methods

Electronic leak detectors may be used to detect refrigerant leaks but, in the case of flammable refrigerants, the sensitivity may not be adequate, or may need re-calibration. (Detection equipment shall be calibrated in a refrigerant-free area.)

Ensure that the detector is not a potential source of ignition and is suitable for the refrigerant used. Leak detection equipment shall be set at a percentage of the LFL of the refrigerant and shall be calibrated to the refrigerant employed, and the appropriate percentage of gas (25% maximum) is confirmed.

Leak detection fluids are suitable for use with most refrigerants but the use of detergents containing chlorine shall be avoided as the chlorine may react with the refrigerant and corrode the copper pipe-work.

If a leak is suspected, all naked flames shall be removed/extinguished.

If a leakage of refrigerant is found which requires brazing, all of the refrigerant shall be recovered from the system, or isolated (by means of shut off valves) in a part of the system remote from the leak. For appliances containing flammable refrigerants, oxygen free nitrogen (OFN) shall then be purged through the system both before and during the brazing process.

7. Removal and Evacuation

When breaking into the refrigerant circuit to make repairs – or for any other purpose conventional procedures shall be used. However, for flammable refrigerants it is important that best practice is followed since flammability is a consideration. The following procedure shall be adhered to:

- remove refrigerant
- purge the circuit with inert gas
- evacuate
- purge again with inert gas
- open the circuit by cutting or brazing.

The refrigerant charge shall be recovered into the correct recovery cylinders. For appliances containing flammable refrigerants, the system shall be “flushed” with OFN to render the unit safe. This process may need to be repeated several times.

Compressed air or oxygen shall not be used for purging refrigerant systems.

For appliances containing flammable refrigerants, flushing shall be achieved by breaking the vacuum in the system with OFN and continuing to fill until the working pressure is achieved, then venting to atmosphere, and finally pulling down to a vacuum. This process shall be repeated until no refrigerant is within the system. When the final OFN charge is used, the system shall be vented down to atmospheric pressure to enable work to take place. This operation is absolutely vital if brazing operations on the pipe-work are to take place.

Ensure that the outlet for the vacuum pump is not close to any ignition sources and that ventilation is available.

8. Charging Procedures

In addition to conventional charging procedures, the following requirements shall be followed:

- Ensure that contamination of different refrigerants does not occur when using charging equipment. Hoses or lines shall be as short as possible to minimize the amount of refrigerant contained in them.
- Cylinders shall be kept upright.
- Ensure that the refrigeration system is earthed prior to charging the system with refrigerant.
- Label the system when charging is complete (if not already).
- Extreme care shall be taken not to overfill the refrigeration system.

Prior to recharging the system, it shall be pressure-tested with the appropriate purging gas. The system shall be leak-tested on completion of charging but prior to commissioning. A follow up leak test shall be carried out prior to leaving the site.

9. Decommissioning

Before carrying out this procedure, it is essential that the technician is completely familiar with the equipment and all its detail. It is recommended good practice that all refrigerants are recovered safely. Prior to the task being carried out, an oil and refrigerant sample shall be taken in case analysis is required prior to re-use of reclaimed refrigerant. It is essential that electrical power is available before the task is commenced.

- (1) Become familiar with the equipment and its operation.
- (2) Isolate system electrically.
- (3) Before attempting the procedure, ensure that:
 - mechanical handling equipment is available, if required, for handling refrigerant cylinders;
 - all personal protective equipment is available and being used correctly;
 - the recovery process is supervised at all times by a competent person;
 - recovery equipment and cylinders conform to the appropriate standards.
- (4) Pump down refrigerant system, if possible.
- (5) If a vacuum is not possible, make a manifold so that refrigerant can be removed from various parts of the system.
- (6) Make sure that cylinder is situated on the scales before recovery takes place.
- (7) Start the recovery machine and operate in accordance with manufacturer's instructions.
- (8) Do not overfill cylinders. (No more than 80 % volume liquid charge).
- (9) Do not exceed the maximum working pressure of the cylinder, even temporarily.
- (10) When the cylinders have been filled correctly and the process completed, make sure that the cylinders and the equipment are removed from site promptly and all isolation valves on the equipment are closed off.
- (11) Recovered refrigerant shall not be charged into another refrigeration system unless it has been cleaned and checked.

10. Labelling

Equipment shall be labelled stating that it has been de-commissioned and emptied of refrigerant. The label shall be dated and signed. For appliances containing flammable refrigerants, ensure that there are labels on the equipment stating the equipment contains flammable refrigerant.

11. Recovery

When removing refrigerant from a system, either for servicing or decommissioning, it is recommended good practice that all refrigerants are removed safely. When transferring refrigerant into cylinders, ensure that only appropriate refrigerant recovery cylinders are employed. Ensure that the correct number of cylinders for holding the total system charge are available. All cylinders to be used are designated for the recovered refrigerant and labelled for that refrigerant (i.e. special cylinders for the recovery of refrigerant). Cylinders shall be complete with pressure-relief valve and associated shut-off valves in good working order. Empty recovery cylinders are evacuated and, if possible, cooled before recovery occurs. The recovery equipment shall be in good working order with a set of instructions concerning the equipment that is at hand and shall be suitable for the recovery of all appropriate refrigerants including, when applicable, flammable refrigerants. In addition, a set of calibrated weighing scales shall be available and in good working order. Hoses shall be complete with leak-free disconnect couplings and in good condition. Before using the recovery machine, check that it is in satisfactory working order, has been properly maintained and that any associated electrical components are sealed to prevent ignition in the event of a refrigerant release. Consult manufacturer if in doubt.

The recovered refrigerant shall be returned to the refrigerant supplier in the correct recovery cylinder, and the relevant waste transfer note arranged. Do not mix refrigerants in recovery units and especially not in cylinders. If compressors or compressor oils are to be removed, ensure that they have been evacuated to an acceptable level to make certain that flammable refrigerant does not remain within the lubricant. The evacuation process shall be carried out prior to returning the compressor to the suppliers. Only electric heating to the compressor body shall be employed to accelerate this process. When oil is drained from a system, it shall be carried out safely.

3

PART NAMES AND FUNCTIONS

INDOOR UNIT

MLZ-KY20VG

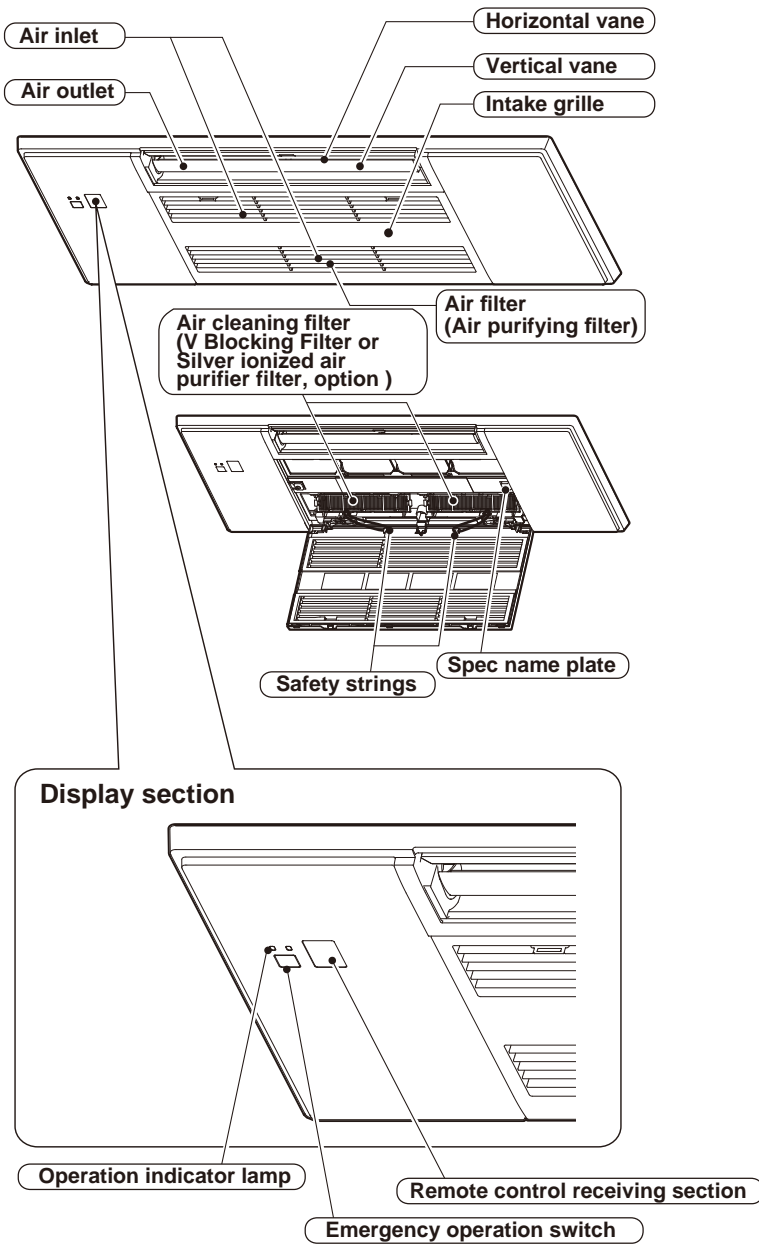

ACCESSORIES

MODELS	MLZ-KY20VG
(1) Alkaline battery (AAA) for remote controller	2
(2) Drain hose (with insulation)	1
(3) Special washer (with cushion, 4pcs)	8
(4) Installation template	1
(5) Fixing screw for (4) M5 x 30 mm	4
(6) Band	1
(7) Fixing screw for (6) 4 x 16 mm	2
(8) Remote controller	1
(9) Remote controller holder	1
(10) Fixing screw for (9) 3.5 x 16 mm (Black)	2

4

SPECIFICATION

Indoor model			MLZ-KY20VG	
Function			Cooling	Heating
Power supply			Single phase 230V, 50Hz	
Capacity	Air flow (High/Med./Low/SLow)	m ³ /h	336/312/282/258	360/330/294/258
Electrical data	Running current *1	A	0.12	
	Power input *1	W	12	
	Auxiliary heater	A(kW)	-	
	Power factor *1	%	43.5	
	Fan motor current *1	A	0.12	
Fan motor	Model		RC0J30-QH	
	Dimensions W x H x D	mm	842x194x301	
	Weight	kg	11	
Special remarks	Air direction		5	
	Sound level (High/Med./Low/SLow)	dB(A)	37/34/32/30	38/35/32/29
	Fan speed (High/Med./Low/SLow)	rpm	1080/1010/940/860	1150/1070/970/860
	Fan speed regulator		4	
Remote controller model			SH21E	

NOTE: Test conditions are based on ISO 5151.

Cooling: Indoor Dry-bulb temperature 27°C Wet-bulb temperature 19°C

Outdoor Dry-bulb temperature 35°C

Heating: Indoor Dry-bulb temperature 20°C

Outdoor Dry-bulb temperature 7°C Wet-bulb temperature 6°C

Refrigerant piping length (one way): 5m

*1 Measured under rated operating frequency. (Only indoor unit)

Specifications and rated conditions of main electric parts

Item	Model	MLZ-KY20VG
Fuse	(F11)	T3.15AL250V
Horizontal vane motor	(MV1)	12 V DC
Vertical vane motor	(MV2)	12 V DC
Varistor	(NR11)	470 V
DRAIN PUMP	(DP)	230 V 6.4 W
DRAIN SENSOR	(DS)	Thermistor 25°C 5.3kΩ

5

NOISE CRITERIA CURVES

MLZ-KY20VG

FAN SPEED	FUNCTION	SPL(dB(A))	LINE
High	COOLING	37	●—●
	HEATING	38	○—○

Test conditions,

Cooling: Dry-bulb temperature 27°C Wet-bulb temperature 19°C
 Heating: Dry-bulb temperature 20°C

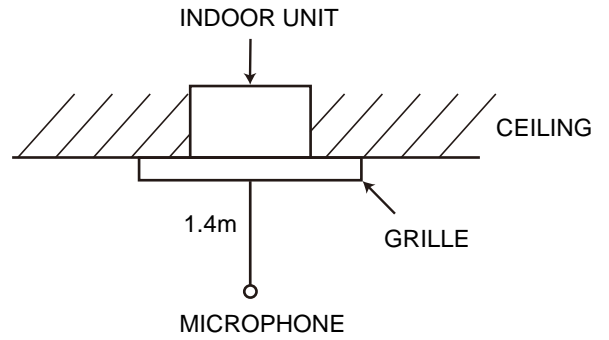
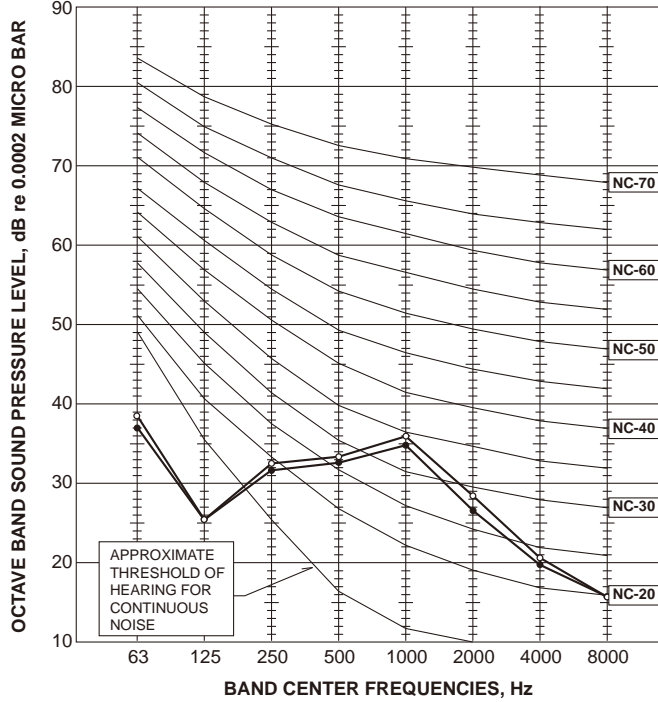

MLZ-KY20VG

Unit: mm

INDOOR UNIT

INDOOR UNIT OUTLINE DRAWING

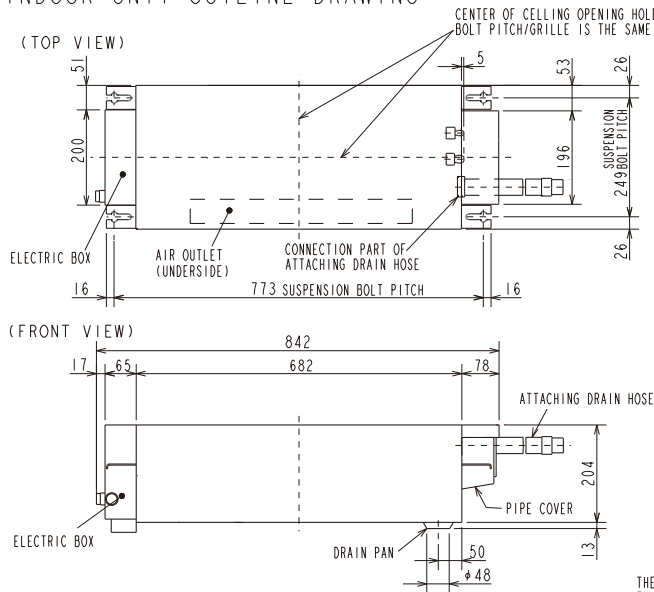

REMOTE CONTROLLER OUTLINE DRAWING

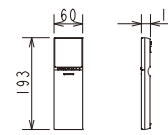

(RIGHT SIDE VIEW)

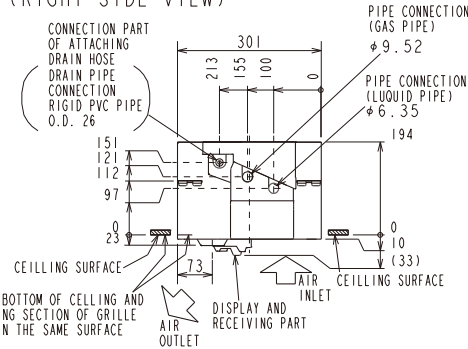

GRILLE OUTLINE DRAWING (MLP-448W)

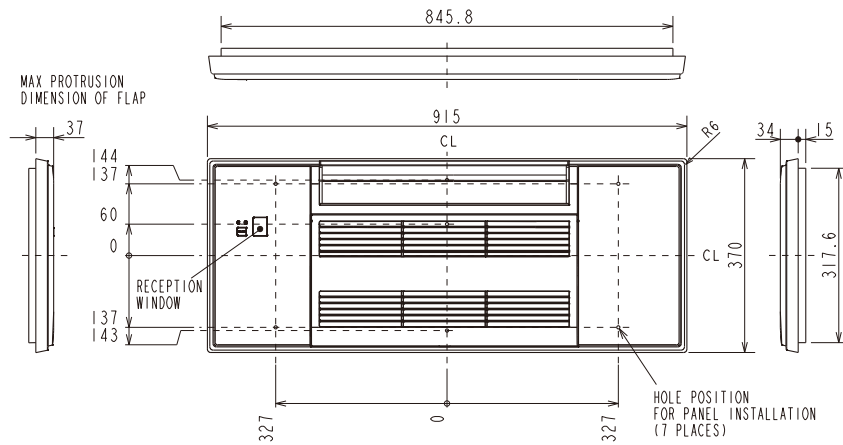

EXTENSION PIPE	LIQUID PIPE O.D.	$\phi 6.35$	
	GAS PIPE O.D.	$\phi 9.52$	
CONNECTION OF PIPE	LIQUID PIPE	FLARED CONNECTION $\phi 6.35$	
	GAS PIPE	FLARED CONNECTION $\phi 9.52$	
DRAIN HOSE	HEAT INSULATOR O.D.	CONNECTION I.D.	EFFECTIVE LENGTH
	$\phi 32$	$\phi 25$	480
	DRAIN PIPE CONNECTION RIGID PVC PIPE O.D. $\phi 26$		

NOTE1. CUT THE DRAIN HOSE (ACCESSORY) FOR USE, IF NECESSARY.

INDOOR UNIT DETAIL VIEW

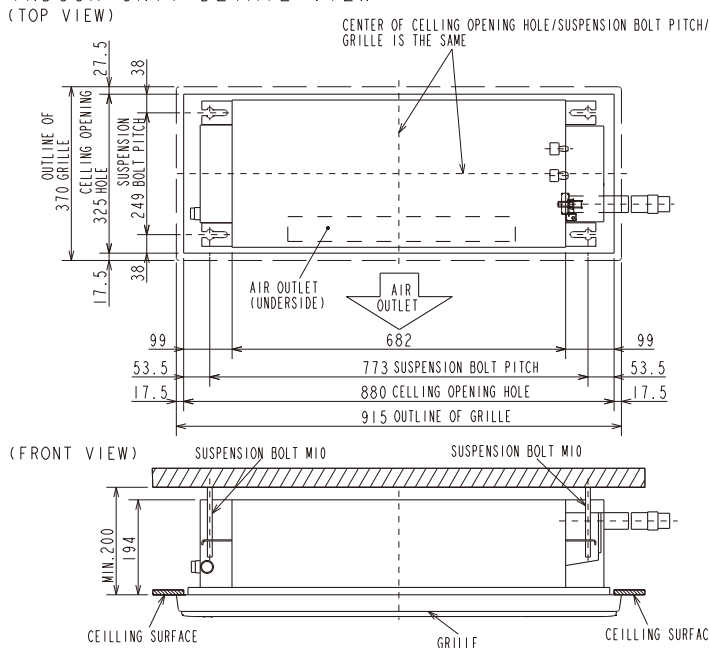

THE METHOD FOR STANDING DRAIN FROM INDOOR UNIT
* CUT THE DRAIN HOSE (ACCESSORY) FOR USE, IF NECESSARY.

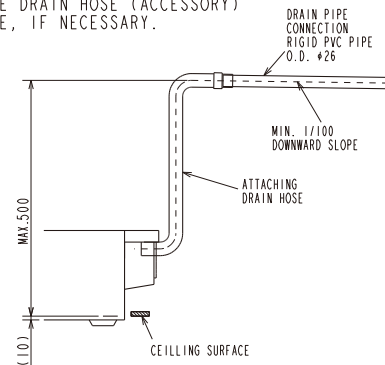

7

WIRING DIAGRAM

MLZ-KY20VG-E1

INDOOR UNIT

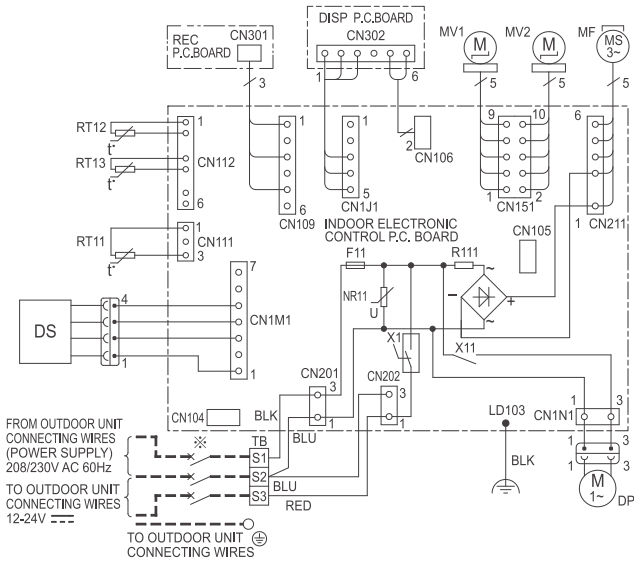

SYMBOL	NAME	SYMBOL	NAME
MF	FAN MOTOR	RT11	ROOM TEMP. THERMISTOR
MV1	HORIZONTAL VANE MOTOR	RT12	COIL TEMP. THERMISTOR(MAIN)
MV2	VERTICAL VANE MOTOR	RT13	COIL TEMP. THERMISTOR(SUB)
DP	DRAIN PUMP	NR11	VARISTOR
DS	DRAIN SENSOR	R111	RESISTOR
F11	FUSE (T3.15AL250V)	CN105	IT TERMINAL
X11	RELAY	X1	RELAY
TB	TERMINAL BLOCK		

NOTES :

1. About the outdoor side electric wiring refer to the outdoor unit electric wiring diagram for servicing.
2. Use copper conductors only.
3. Symbols below indicate.

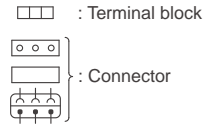

MLZ-KY20VG- E1

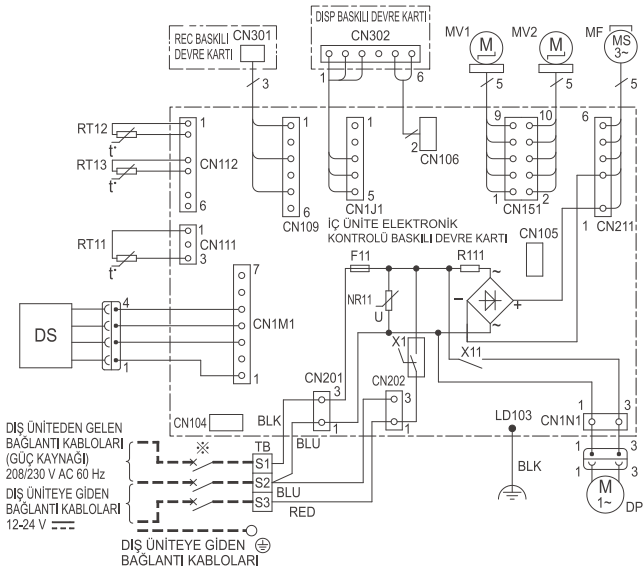

SEMBOL	PARÇA ADI	SEMBOL	PARÇA ADI
MF	FAN MOTORU	RT11	ODA SICAKL. TERMİSTÖRÜ
MV1	YATAY PERVANE MOTORU	RT12	BOBİN SICAKL. TERMİSTÖRÜ (ASIL)
MV2	DIKEY KANATÇIK MOTORU	RT13	COIL TEMP. THERMISTOR(SUB)
DP	DRENAJ POMPASI	NR11	VARİSTÖR
DS	DRENAJ SENSÖRÜ	R111	DİRENÇ
F11	SİGORTA (T3.15AL250V)	CN105	IT TERMİNALİ
X11	RÖLE	X1	RÖLE
TB	TERMINAL BLOĞU		

NOTLAR:

1. Dış ünite elektrik şeması ile ilgili servis için dış ünite elektrik şemasına bakın.
2. Sadece bakır kablolar kullanın. (Saha kablo bağlantısı için)
3. Aşağıdaki sembollerin açıklaması.

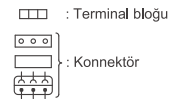

INDOOR UNIT

MLZ-KY20VG

Unit: mm

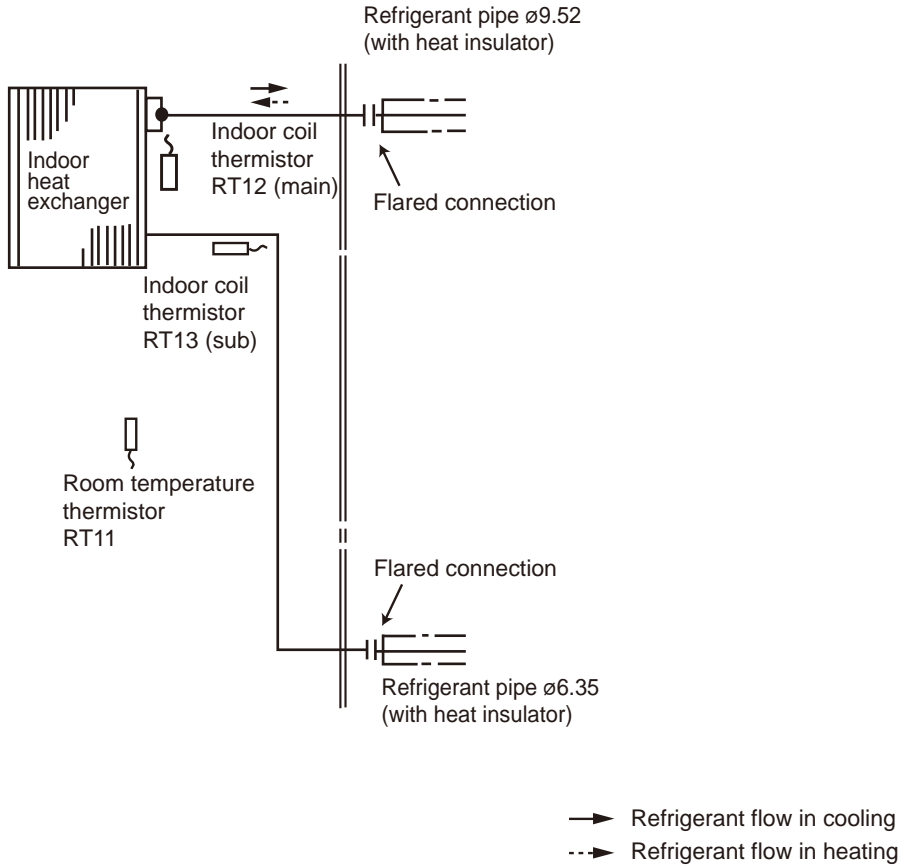

MLZ-KY20VG

9-1. TIMER SHORT MODE

- For service, the following set time can be shortened by bridging the timer short mode point on the electronic control P.C. board. (Refer to 11-7.)
- The set time for the ON/OFF timer can be reduced to 1 second for each minute.
- After the breaker is turned on, the time for starting the compressor, which normally takes 3 minutes, can be reduced to 3 seconds. Restarting the compressor, which takes 3 minutes, cannot be reduced.

9-2. HOW TO SET REMOTE CONTROLLER EXCLUSIVELY FOR A PARTICULAR INDOOR UNIT

A maximum of 4 indoor units with wireless remote controllers can be used in a room.

To operate the indoor units individually with each remote controller, assign a number to each remote controller according to the number of the indoor unit.

This setting can be set only when all the following conditions are met:

- The remote controller is powered OFF.
- Weekly timer is not set.
- Weekly timer is not being edited.

1. How to modify the electronic control P.C. board

Turn OFF the power supply before modification. To assign a number to each indoor unit, cut off "JR05" and "JR06" on the electronic control P.C. board as shown in Table 1. (Refer to 11-7.)

Table 1

	JR05	JR06
Unit No. 1	No modification	No modification
Unit No. 2	Cut off JR05	No modification
Unit No. 3	No modification	Cut off JR06
Unit No. 4	Cut off JR05	Cut off JR06

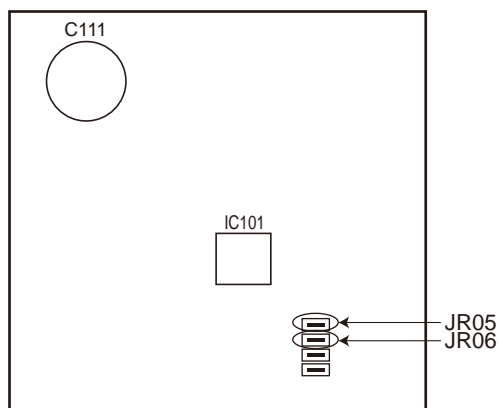

2. How to set the remote controller

- (1) Hold down [1~4] button on the remote controller for 2 seconds to enter the pairing mode.
- (2) Press [1~4] button again and assign a number to each remote controller.
Each press of [1~4] button advances the number in the following order: 1 → 2 → 3 → 4.
- (3) Press  button to complete the pairing setting.

After the setting, turn ON the power supply and with the remote controller headed towards the indoor unit, press the OFF/ON (stop/operate) button. If 1 or 2 beeps is heard from the indoor unit, the setting is completed correctly. The remote controller that first sends a signal to an indoor unit will be regarded as the remote controller for the indoor unit.

Once they are set, the indoor unit will only receive the signal from the assigned remote controller afterwards.

9-3. AUTO RESTART FUNCTION

When the indoor unit is controlled with the remote controller, the operation mode, the set temperature, and the fan speed are memorized by the indoor electronic control P.C. board. "AUTO RESTART FUNCTION" automatically starts operation in the same mode just before the shutoff of the main power.

Operation

- ① If the main power has been cut, the operation settings remain.
- ② After the power is restored, the unit restarts automatically according to the memory.
(However, it takes at least 3 minutes for the compressor to start running.)

How to disable "AUTO RESTART FUNCTION"

- ① Turn off the main power for the unit.
- ② Cut the jumper wire to JR77 on the indoor electronic control P.C. board. (Refer to 11-7.)

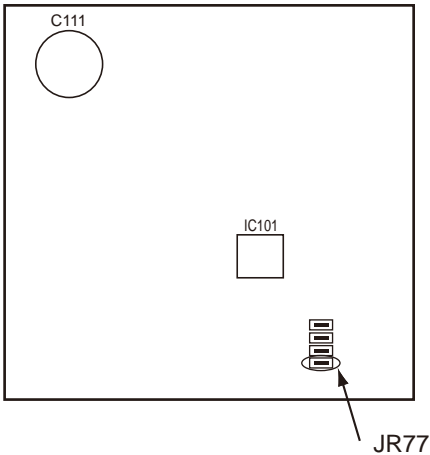

NOTE:

- The operation settings are memorized when 10 seconds has passed after the indoor unit was operated with the remote controller.
- If main power is turned OFF or a power failure occurs while AUTO START/STOP timer is active, the timer setting is cancelled.
- If the unit has been off with the remote controller before power failure, the auto restart function does not work as the power button of the remote controller is off.
- To prevent breaker tripping due to the rush of starting current, systematize other home appliance not to turn on at the same time.
- When some air conditioners are connected to the same supply system, if they are operated before power failure, the starting current of all the compressors may flow simultaneously at restart. Therefore, the special counter-measures are required to prevent the main voltage-drop or the rush of the starting current by adding to the system that allows the units to start one by one.

9-4. P.C. BOARD MODIFICATION FOR CHANGING AIRFLOW VOLUME

Change dip switch SW3 setting according to the height of ceiling.

Dip switch SW3	Normal	Increase airflow volume
Ceiling height	2.4 m or below	above 2.4 m and 2.7 m or below

NOTE: When the ceiling is above 2.7 m, airflow volume may be insufficient even with the Dip switch (SW3) set to "increase airflow".

How to change Dip switch (SW3) setting (Factory setting is normal)

1. Make sure that the breaker for air conditioner is turned OFF.
2. Remove the disp cover of the indoor unit.
3. Slide out the electronic control P.C. board, and switch up the slide switch (SW).
4. Put the electronic control P.C. board back to the original position, and install the disp cover.

NOTE:

- Perform static elimination before setting.

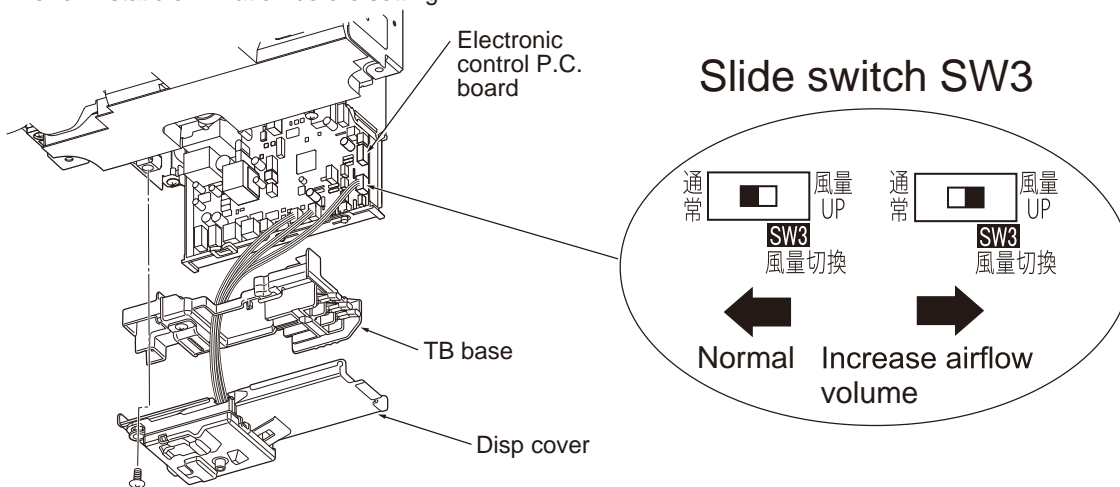

9-5. P.C. BOARD MODIFICATION FOR CHANGING AIRFLOW DIRECTION ADJUSTMENT

The setting when the lower airflow is preferred in the Airflow direction (1)

The angle of airflow direction (1) can be slightly lowered by changing SWV1 to normal when the lower airflow is preferred or the airflow causes the dirt on the ceiling.

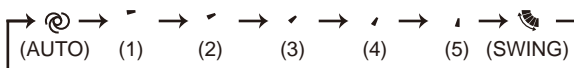

How to change Dip switch (SWV1) setting (Factory setting is up)

1. Make sure that the breaker for air conditioner is turned OFF.
2. Remove the disp cover of the indoor unit.
3. Slide out the electronic control P.C. board, and change the slide switch (SWV1) to normal.
4. Put the electronic control P.C. board back to the original position, and install the disp cover.

NOTE:

- Perform static elimination before setting.

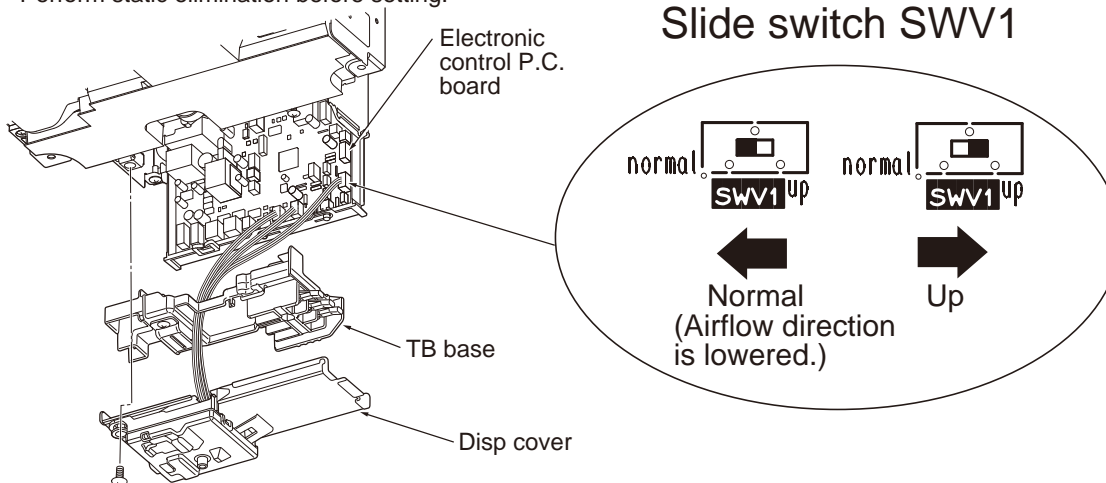

MLZ-KY20VG

WIRELESS REMOTE CONTROLLER

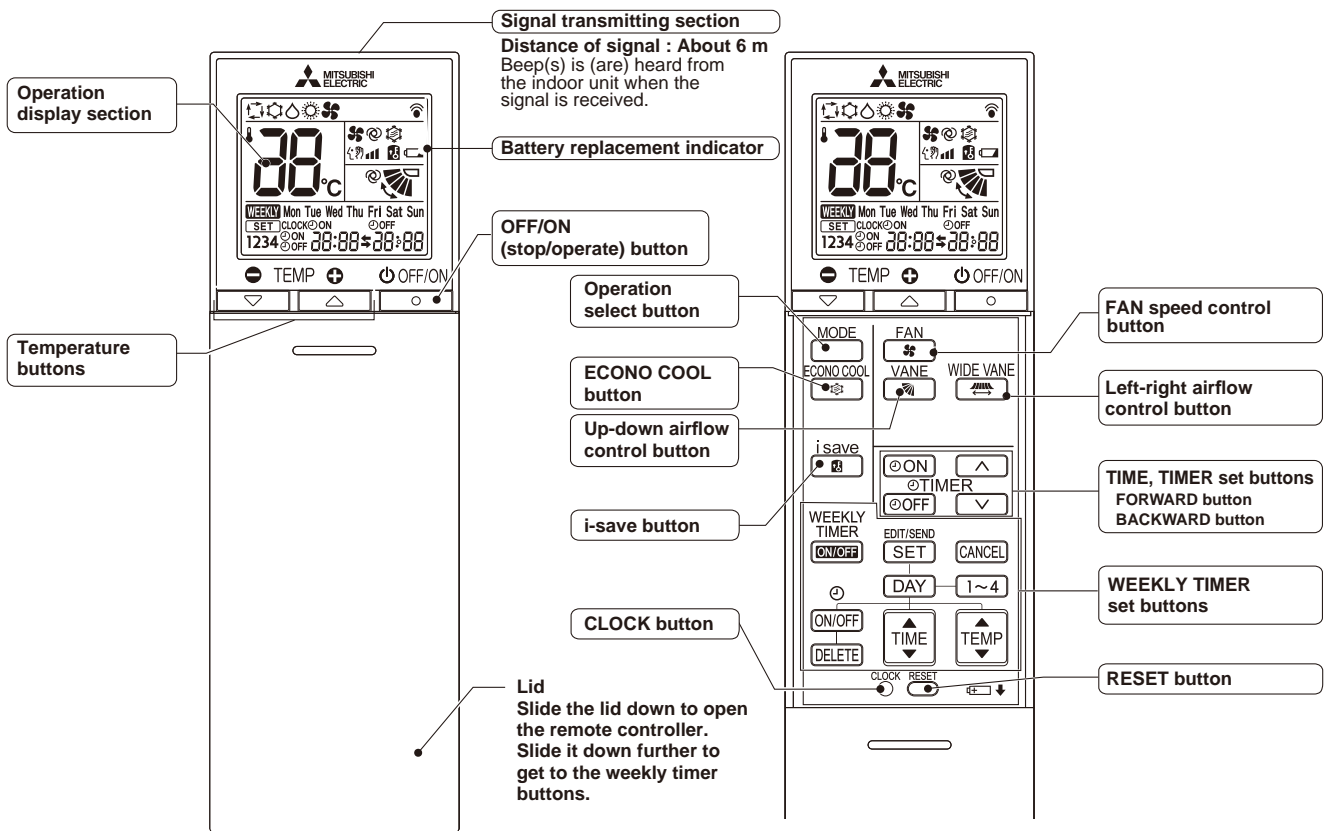

NOTE: Last setting will be stored after the unit is turned OFF with the remote controller. Indoor unit receives the signal of the remote controller with beeps.

INDOOR UNIT DISPLAY SECTION

Operation Indicator Lamp

The operation indicator at the right side of the indoor unit indicates the operation state.

•The following indication applies regardless of shape of the indication.

Indication	Operation state	Room temperature
● ●	The unit is operating to reach the set temperature	About 2°C or more away from set temperature
● ○	The room temperature is approaching the set temperature	About 1 to 2°C from set temperature
● ●	Standby mode (Refer to multi system operation)	—

- Lit
- Blinking
- Not lit

10-1. COOL (❄️) OPERATION

- (1) Press OFF/ON (stop/operate) button.
OPERATION INDICATOR lamp of the indoor unit turns on with a beep tone.
- (2) Select COOL mode with Operation select button.
- (3) Press Temperature buttons TEMP \ominus or \oplus button to select the desired temperature. The setting range is 16 - 31°C.

1. Coil frost prevention

The compressor operational frequency is controlled by the temperature of the indoor heat exchanger to prevent the coil from frosting.

When the temperature of indoor heat exchanger becomes too low, the coil frost prevention mode works.

The indoor fan operates at the set speed and the compressor stops. This mode continues until the temperature of indoor heat exchanger rises.

10-2. DRY (☀️) OPERATION

- (1) Press OFF/ON (stop/operate) button.
OPERATION INDICATOR lamp of the indoor unit turns on with a beep tone.
- (2) Select DRY mode with Operation select button.
- (3) The set temperature is determined from the initial room temperature.

1. Coil frost prevention

Coil frost prevention works the same way as that in COOL mode. (10-1.1.)

10-3. FAN (🌀) OPERATION

- (1) OPERATION INDICATOR lamp of the indoor unit turns on with a beep tone.
- (2) Select FAN mode with Operation select button.
- (3) Select the desired fan speed. When AUTO, it becomes Low.
Only indoor fan operates.
Outdoor unit does not operate.

10-4. HEAT (🔥) OPERATION

- (1) Press OFF/ON (stop/operate) button.
OPERATION INDICATOR lamp of the indoor unit turns on with a beep tone.
- (2) Select HEAT mode with Operation select button.
- (3) Press Temperature buttons TEMP \ominus or \oplus button to select the desired temperature. The setting range is 10°C and 16 - 31°C.

1. Cold air prevention control

When the compressor is not operating or is starting, and the temperature of indoor heat exchanger and/or the room temperature is low or when defrosting is being done, the indoor fan will stop or rotate in Very Low speed.

2. Defrosting

Defrosting starts when the temperature of outdoor heat exchanger becomes too low.

The compressor stops once, the indoor/outdoor fans stop, the 4-way valve reverses, and the compressor re-starts.

This mode continues until the temperature of outdoor heat exchanger rises or the fixed time passes.

10-5. AUTO CHANGE OVER ... AUTO MODE OPERATION

Once desired temperature is set, unit operation is switched automatically between COOL and HEAT operation.

Mode selection

(1) Initial mode

When unit starts the operation with AUTO operation from OFF:

- If the room temperature is higher than the set temperature, operation starts in COOL mode.
- If the room temperature is equal to or lower than the set temperature, operation starts in HEAT mode.

(2) Mode change

COOL mode changes to HEAT mode when about 15 minutes have passed with the room temperature 2°C below the set temperature.

HEAT mode changes to COOL mode when about 15 minutes have passed with the room temperature 2°C above the set temperature.

NOTE 1

If 2 or more indoor units are operating in multi system, there might be a case that the indoor unit, which is operating in

☐ (AUTO), cannot change over to the other operating mode (COOL ↔ HEAT) and becomes a state of standby.

Refer to **NOTE 2 "FOR MULTI SYSTEM AIR CONDITIONER"**.

NOTE 2

FOR MULTI SYSTEM AIR CONDITIONER

OUTDOOR UNIT: MXZ series

Multi system air conditioner can connect 2 or more indoor units with one outdoor unit.

- When you try to operate 2 or more indoor units with one outdoor unit simultaneously, one for the cooling and the others for heating, the operation mode of the indoor unit that operates first is selected. Other indoor units cannot operate, and operation indicator lamp blinks as shown in the figure below. In this case, please set all the indoor units to the same operation mode.

OPERATION INDICATOR

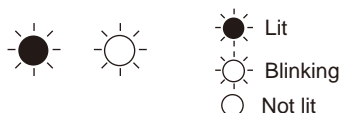

- When indoor unit starts the operation while the defrosting of outdoor unit is being done, it takes a few minutes (max. 10 minutes) to blow out the warm air.
- In the heating operation, though indoor unit that does not operate may get warm or the sound of refrigerant flowing may be heard, they are not malfunction. The reason is that the refrigerant continuously flows into it.

10-6. AUTO VANE OPERATION

1. Horizontal vane

(1) Vane motor drive

These models are equipped with a stepping motor for the horizontal vane. The rotating direction, speed, and angle of the motor are controlled by pulse signals (approximately 12 V) transmitted from indoor microprocessor.

- (2) The horizontal vane angle and mode change as follows by pressing VANE CONTROL button.

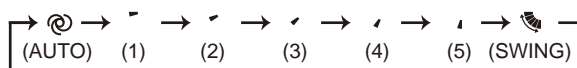

NOTE:

The setting when the lower airflow is preferred in the Airflow direction (1)

The angle of airflow direction (1) can be slightly lowered by changing SWV1 to normal when the lower airflow is preferred or the airflow causes the dirt on the ceiling.

(Refer to 9-5. P.C. BOARD MODIFICATION FOR CHANGING AIRFLOW DIRECTION ADJUSTMENT.)

Factory setting is up.

(3) Positioning

To confirm the standard position, the vane moves until it touches the vane stopper. Then the vane is set to the selected angle.

Confirming of standard position is performed in the following cases:

- When the power supply turns on.
- When the operation starts or finishes (including timer operation).
- When the test run starts.
- When multi-standby starts or finishes.
- When the swing operation finishes.

(4) VANE AUTO (⊙) mode

In VANE AUTO mode, the microprocessor automatically determines the vane angle and operation to make the optimum room-temperature distribution.

- (1) In COOL and DRY operation Vane angle is fixed to Angle 1.

- (2) In HEAT operation Vane angle is fixed to Angle 4.

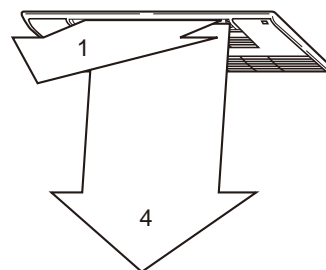

(5) STOP (operation OFF) and ON TIMER standby

In the following cases, the horizontal vane returns to the closed position.

- When OFF/ON (stop/operate) button is pressed (POWER OFF).
- When the operation is stopped by the emergency operation.
- When ON TIMER is ON standby.

(6) SWING  mode

By selecting SWING mode with VANE CONTROL button, the horizontal vanes swing vertically.
When COOL, DRY or FAN mode is selected, only the upper vane swings.

(7) Cold air prevention in HEAT operation

The horizontal vane position is set to upward.

(8) ECONO COOL  operation (ECONOMical operation)

When ECONO COOL button is pressed in COOL mode, set temperature is automatically set 2°C higher by micro-processor. However, the temperature on the LCD screen on the remote controller is not changed.

Also the horizontal vane swings in various cycle.

SWING operation makes you feel cooler than set temperature. So, even though the set temperature is higher, the air conditioner can keep comfort. As a result, energy can be saved.

To cancel this operation, select a different mode or press one of the following buttons in ECONO COOL operation: ECONO COOL, WIDE VANE CONTROL or VANE CONTROL button.

2. Vertical vane

(1) Press WIDE VANE CONTROL button to change horizontal airflow direction.

•The vertical vane moves for about 30 seconds.

(After 30 seconds, the vertical vane moves to its original position. In this case, press WIDE VANE CONTROL button again.)

(2) Press WIDE VANE CONTROL button again to set horizontal airflow direction.

•The vertical vane stops and the airflow direction is set.

(3) Positioning

To confirm the standard position, the vane moves until it touches the vane stopper. Then the vane set to the desired angle.

Confirming of standard position is performed in the following cases:

(a) When OFF/ON (stop/operate) button is pressed (POWER ON).

(b) When SWING is started.

10-7. DRAIN PUMP CONTROL

1. Drain pump

Operating conditions:

1. During COOL, DRY, or emergency COOL operation
2. When the drain sensor detects the water level above the fixed point during the following states:
 - (a) Standby during multi system operation
 - (b) Standby while the ON timer is set
 - (c) Operation stop
3. When there is a failure on the drain sensor

Drain pump operates in conditions 1,2 or 3.

Stop conditions:

States other than 1 or 2 indicated above

10-8. TIMER OPERATION

1. How to set the time

- (1) Check that the current time is set correctly.

NOTE: Timer operation will not work without setting the current time. Initially "0:00" blinks at the current time display of TIME MONITOR, so set the current time correctly with CLOCK SET button.

How to set the current time

- (a) Press the CLOCK set button.
 (b) Press the TIME SET buttons (▲) and (▼) to set the current time.
 • Each time FORWARD button (▲) is pressed, the set time increases by 1 minute, and each time BACKWARD button (▼) is pressed, the set time decreases by 1 minute.
 • Pressing those buttons longer, the set time increases/decreases by 10 minutes.
 (c) Press the CLOCK set button.
 (2) Press OFF/ON (stop/operate) button to start the air conditioner.
 (3) Set the time of timer.

ON timer setting

- (a) Press ON TIMER button (ⓄON) during operation.
 (b) Set the time of the timer using TIME SET buttons (▲) and (▼).*

OFF timer setting

- (a) Press OFF TIMER button (ⓄOFF) during operation.
 (b) Set the time of the timer using TIME SET buttons (▲) and (▼).*

* Each time FORWARD button (▲) is pressed, the set time increases by 10 minutes: each time BACKWARD button (▼) is pressed, the set time decreases by 10 minutes.

2. To release the timer

To release ON timer, press ON TIMER button (ⓄON).

To release OFF timer, press OFF TIMER button (ⓄOFF).

TIMER is cancelled and the display of set time disappears.

PROGRAM TIMER

- OFF timer and ON timer can be used in combination. The set time that is reached first will operate first.
- "←" and "→" display shows the order of OFF timer and ON timer operation.

(Example 1) The current time is 8:00 PM.

The unit turns off at 11:00 PM, and on at 6:00 AM.

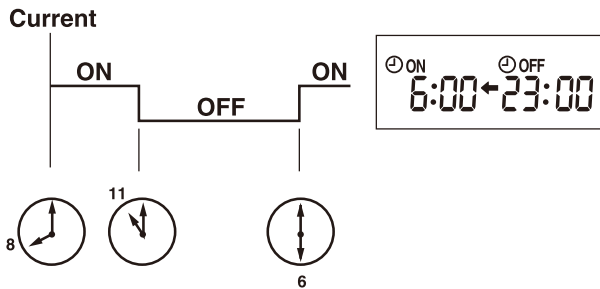

(Example 2) The current time is 11:00 AM.

The unit turns on at 5:00 PM, and off at 9:00 PM.

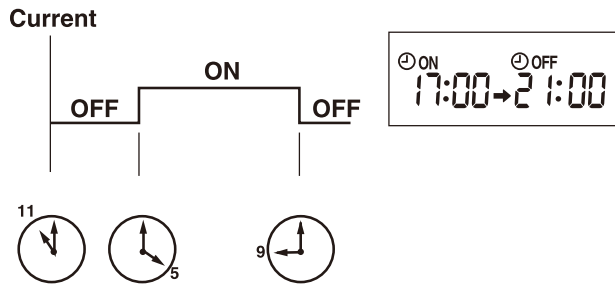

NOTE: If the main power is turned OFF or a power failure occurs while ON/OFF timer is active, the timer setting is cancelled. As these models are equipped with an auto restart function, the air conditioner starts operating with timer cancelled when power is restored.

10-9. WEEKLY TIMER OPERATION

- A maximum of 4 ON or OFF timers can be set for individual days of the week.
- A maximum of 28 ON or OFF timers can be set for a week.

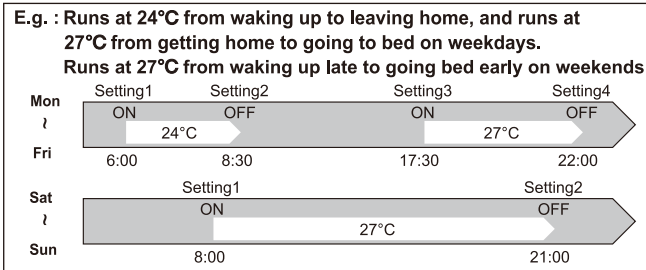

NOTE:

- The simple ON/OFF timer setting is available while the weekly timer is on. In this case, the ON/OFF timer has priority over the weekly timer; the weekly timer operation will start again after the simple ON/OFF timer is complete.
- When the weekly timer is set, temperature cannot be set to 10°C.
- The weekly timer operation and i-save operation cannot be used together.

1. How to set the weekly timer

* Make sure that the current time and day are set correctly.

- (1) Press **EDIT/SEND** **SET** button to enter the weekly timer setting mode.

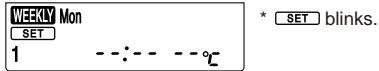

- (2) Press **DAY** and **1~4** buttons to select setting days and/or numbers.

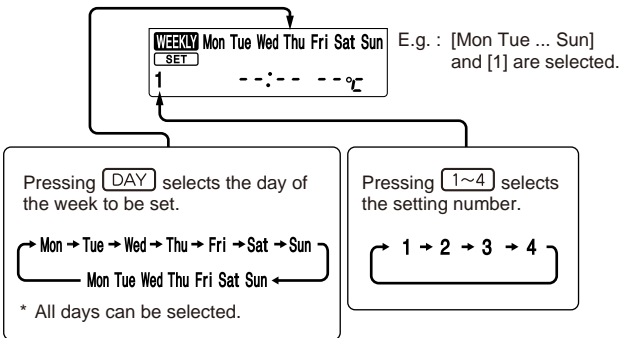

- (3) Press **ON/OFF**, **TIME**, and **TEMP** buttons to set ON/OFF, time, and temperature.

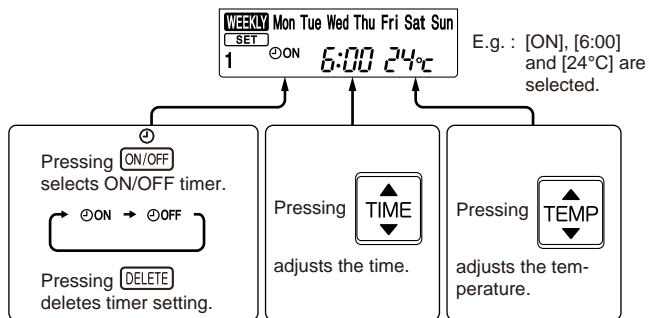

* Hold down the button to change the time quickly.

* The temperature can be set between 16°C and 31°C at weekly timer.





Press **DAY** and **1~4** buttons to continue setting the timer for other days and/or numbers.



(4) Press  button to complete and transmit the weekly timer setting.





*  which was blinking goes out, and the current time will be displayed.

NOTE:

- Press  button to transmit the setting information of weekly timer to the indoor unit. Point the remote controller toward the indoor unit for 3 seconds.
- When setting the timer for more than one day of the week or one number,  button does not have to be pressed per each setting. Press  button once after all the settings are complete. All the weekly timer settings will be saved.
- Press  button to enter the weekly timer setting mode, and press and hold  button for 5 seconds to erase all weekly timer settings. Point the remote controller toward the indoor unit.

(5) Press  button to turn the weekly timer ON. ()

- When the weekly timer is ON, the day of the week whose timer setting is complete, will light.

Press  button again to turn the weekly timer OFF. ()

NOTE:

The saved settings will not be cleared when the weekly timer is turned OFF.

2. Checking weekly timer setting

(1) Press  button to enter the weekly timer setting mode.

*  blinks.

(2) Press  or  buttons to view the setting of the particular day or number.

(3) Press  button to exit the weekly timer setting.

10-10. i-save (iS) OPERATION

1. How to set i-save operation

- (1) Press OFF/ON (stop/operate) button.
- (2) Select COOL or HEAT mode.
- (3) Press i-save button.
- (4) Set the temperature, fan speed, and airflow direction for i-save operation.

NOTE:

- i-save operation cannot be selected during DRY, FAN or AUTO mode operation.
- The setting range of HEAT mode i-save operation is 10°C and 16 - 31°C.
- 2 groups of setting can be saved. (One for COOL, one for HEAT)
- i-save operation and the weekly timer operation cannot be used together.

2. How to cancel operation

- Press i-save button again.
 - i-save operation can also be cancelled by pressing Operation select button to change the operation mode.
- The same setting is selected from the next time by simply pressing i-save button.



10-11. EMERGENCY/TEST OPERATION

In the case of test run operation or emergency operation, use the emergency operation switch on the right side of the indoor unit. Emergency operation is available when the remote controller is missing or has failed, or the batteries in the remote controller are running down. The unit will start and OPERATION INDICATOR lamp will light up. The first 30 minutes of operation is the test run operation. This operation is for servicing. The indoor fan runs at High speed and the temperature control does not work. After 30 minutes of test run operation, the system shifts to EMERGENCY COOL/HEAT MODE with a set temperature of 24°C. The fan speed shifts to Medium. The coil frost prevention works even in the test run or the emergency operation. In the test run or emergency operation, the horizontal vane operates in VANE AUTO (@) mode. Emergency operation continues until the emergency operation switch is pressed once or twice or the unit receives any signal from the remote controller. In the latter case normal operation will start.

NOTE: Do not press the emergency operation switch during normal operation.

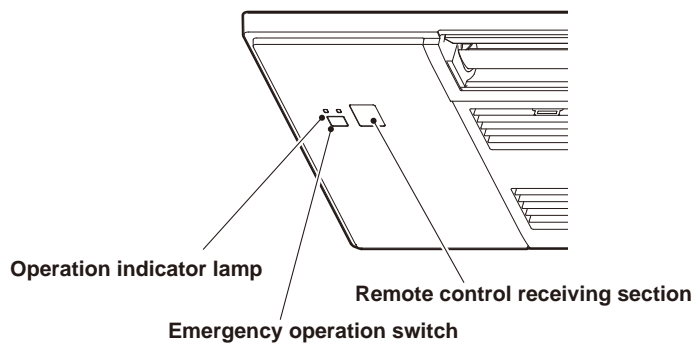

Operation mode	COOL/HEAT
Set temperature	24°C
Fan speed	Medium
Horizontal vane	Auto

The operation mode is indicated by the Operation Indicator lamp as following

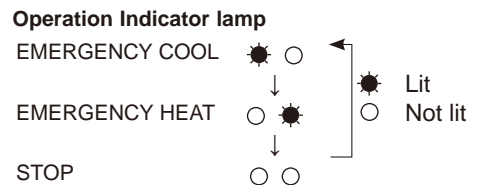

10-12. 3-MINUTE TIME DELAY OPERATION

When the system turns OFF, compressor will not restart for 3 minutes as 3-minute time delay function operates to protect compressor from overload.

MLZ-KY20VG

11-1. CAUTIONS ON TROUBLESHOOTING

1. Before troubleshooting, check the following:

- 1) Check the power supply voltage.
- 2) Check the indoor/outdoor connecting wire for miswiring.

2. Take care of the following during servicing

- 1) Before servicing the air conditioner, be sure to turn off the unit first with the remote controller, and then after confirming the horizontal vane is closed, turn off the breaker and/or disconnect the power plug.
- 2) Be sure to turn OFF the power supply before removing the front panel, the cabinet, the top panel, and the electronic control P.C. board.
- 3) When removing the electronic control P.C. board, hold the edge of the board with care NOT to apply stress on the components.
- 4) When connecting or disconnecting the connectors, hold the connector housing. DO NOT pull the lead wires.

<Incorrect>



Lead wiring

<Correct>

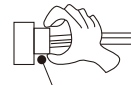

Connector housing

3. Troubleshooting procedure

- 1) Check if the OPERATION INDICATOR lamp on the indoor unit is blinking ON and OFF to indicate an abnormality. To make sure, check how many times the OPERATIONAL INDICATOR lamp is blinking ON and OFF before starting service work.
- 2) Before servicing, verify that all connectors and terminals are connected properly.
- 3) When the electronic control P.C. board seems to be defective, check for disconnection of the copper foil pattern and burnt or discolored components.
- 4) Refer to 11-2, 11-3 and 11-4.

4. How to replace batteries

Weak batteries may cause the remote controller malfunction.

In this case, replace the batteries to operate the remote controller normally.

- ① Remove the front lid and insert batteries. Then reattach the front lid.

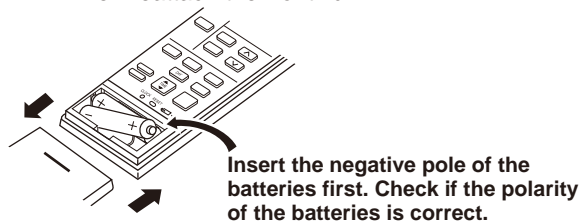

- ② Press RESET button with a fine-tipped object, and then use the remote controller.

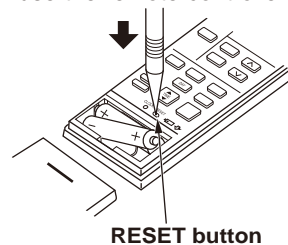

NOTE: 1. If RESET button is not pressed, the remote controller may not operate correctly.

2. This remote controller has a circuit to automatically reset the microcomputer when batteries are replaced.

This function is equipped to prevent the microcomputer from malfunctioning due to the voltage drop caused by the battery replacement.

3. Do not use the leaking batteries.

INFORMATION FOR MULTI SYSTEM AIR CONDITIONER

OUTDOOR UNIT : MXZ series

Multi system air conditioner can connect two or more indoor units with one outdoor unit.

- Unit will not operate in case the total capacity of indoor units exceeds the capacity of outdoor units.

Do not connect indoor units beyond the outdoor unit capacity.

Operation indicator lamp blinks as shown in the figure below.

- When you try to operate two or more indoor units with one outdoor unit simultaneously, one for the cooling and the other for heating, the operation mode of the indoor unit that operates earlier is selected. The other indoor units cannot operate and indicate as shown in the figure below. In this case, please set all the indoor units to the same operation mode.

OPERATION INDICATOR



Lit



Blinking



Not lit

- When indoor units start operation while the defrosting of outdoor unit is being done, it takes a few minutes (maximum 10 minutes) to blow out the warm air.

- In the heating operation, though indoor unit that does not operate may get warm or the sound of refrigerant flowing may be heard, they are not malfunction. The reason is that the refrigerant continuously flows into it.

11-2. FAILURE MODE RECALL FUNCTION

Outline of the function

This air conditioner can memorize the abnormal condition which has occurred once.

Even though LED indication listed on the troubleshooting check table (11-4.) disappears, the memorized failure details can be recalled.

1. Flow chart of failure mode recall function for the indoor/outdoor unit

Operational procedure

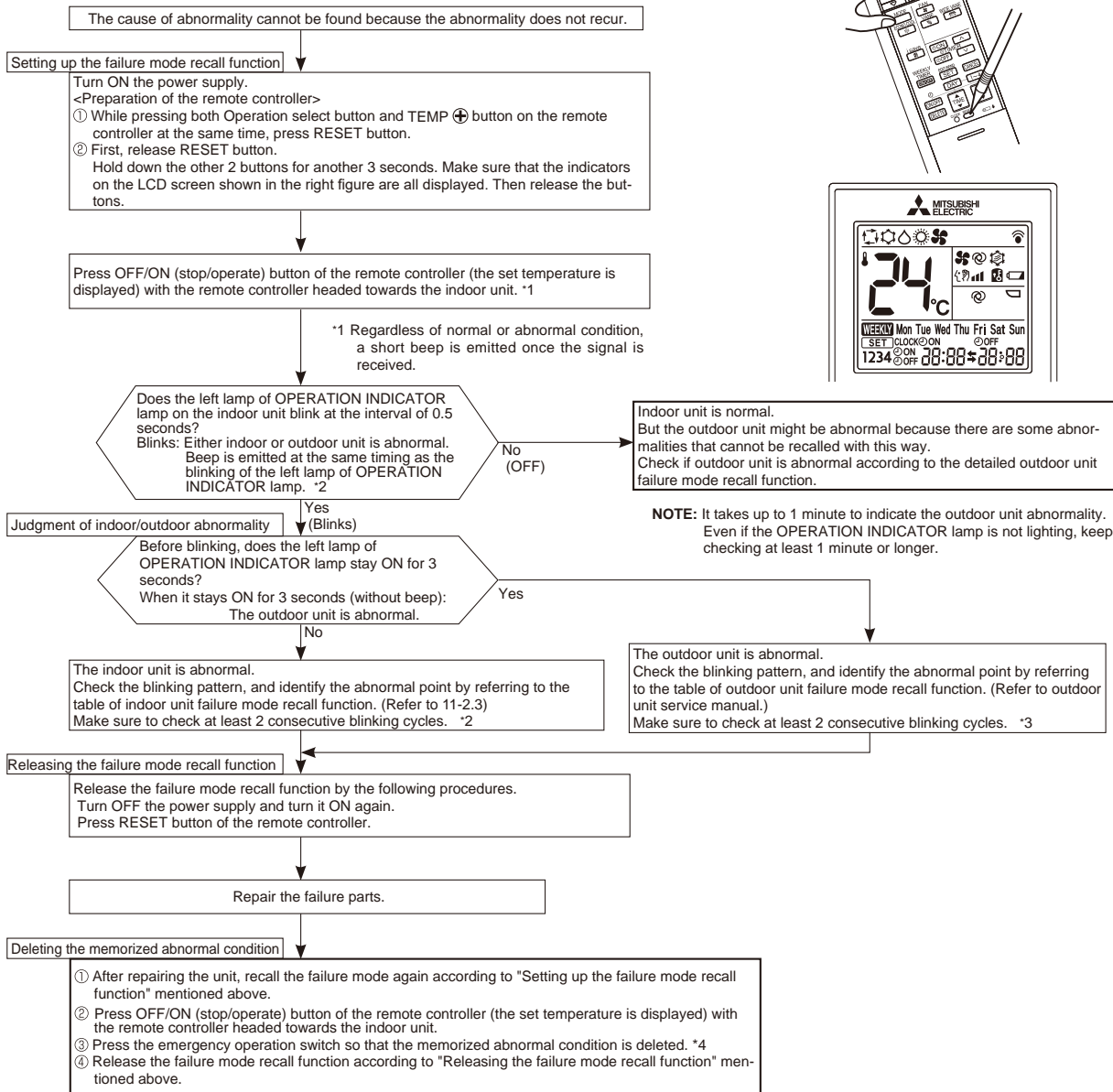

*2. Blinking pattern when the indoor unit is abnormal:

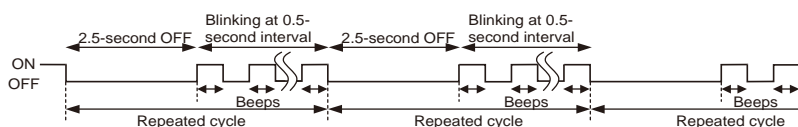

*3. Blinking pattern when the outdoor unit is abnormal:

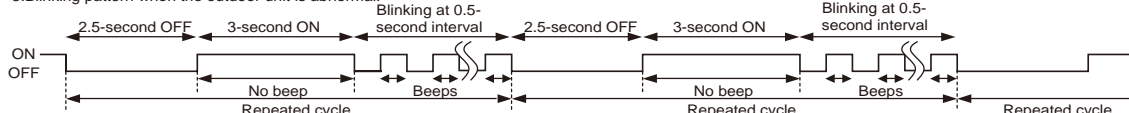

2. Flow chart of the detailed outdoor unit failure mode recall function

Operational procedure

The outdoor unit might be abnormal.
Check if outdoor unit is abnormal according to the following procedures.

Make sure that the remote controller is set to the failure mode recall function.

With the remote controller headed towards the indoor unit, press TOO COOL or TOO WARM button to adjust the set temperature to 25°C. *1

*1. Regardless of normal or abnormal, 2 short beeps are emitted as the signal is received.

Does OPERATION INDICATOR lamp on the indoor unit blink at the interval of 0.5 seconds?
Blinks: The outdoor unit is abnormal.
Beeps are emitted at the same timing as the blinking of OPERATION INDICATOR lamp. *2

No (OFF)

Yes (Blinks)

The outdoor unit is abnormal.
Check the blinking pattern, and identify the abnormal point by referring to the outdoor unit failure mode table (Refer to outdoor unit service manual).
Make sure to check at least 2 consecutive blinking cycles. *2

The outdoor unit is normal.

Release the failure mode recall function according to the left mentioned procedure.

Releasing the failure mode recall function

Release the failure mode recall function by the following procedures.
Turn OFF the power supply and turn it ON again.
Press RESET button of the remote controller.

Repair the failure parts.

Deleting the memorized abnormal condition

- ① After repairing the unit, recall the failure mode again according to "Setting up the failure mode recall function".
- ② Press OFF/ON (stop/operate) button of the remote controller (the set temperature is displayed) with the remote controller headed towards the indoor unit.
- ③ Press the emergency operation switch so that the memorized abnormal condition is deleted.
- ④ Release the failure mode recall function according to "Releasing the failure mode recall function".

Note1. Make sure to release the failure mode recall function after it is set up, otherwise the unit cannot operate properly.
2. If the abnormal condition is not deleted from the memory, the last abnormal condition is kept memorized.

*2. Blinking pattern when outdoor unit is abnormal:

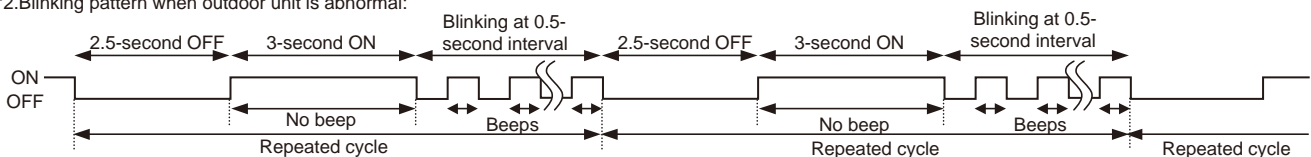

3. Table of indoor unit failure mode recall function

NOTE: Blinking patterns of this mode differs from the ones of Troubleshooting check table (11-4.).

Left lamp of OPERATION INDICATOR lamp	Right lamp of OPERATION INDICATOR lamp	Abnormal point (Failure mode)	Condition	Remedy
Not lit	Not lit	Normal	—	—
1-time blink every 0.5-second	Not lit	Room temperature thermistor	When the room temperature thermistor short or open circuit is detected every 8 seconds during operation.	Refer to the characteristics of the room temperature thermistor (11-7.).
2-time blink 2.5-second OFF	Not lit	Indoor coil thermistor (Main 1, 2 and sub)	When the indoor coil thermistor short or open circuit is detected every 8 seconds during operation.	Refer to the characteristic of the main 1,2 indoor coil thermistor and the sub indoor coil thermistor (11-7.).
3-time blink 2.5-second OFF	Not lit	Serial signal error	When the serial signal from the outdoor unit is not received for a maximum of 6 minutes.	Refer to 11-6. ㉔ "How to check miswiring and serial signal error".
5-time blink 2.5-second OFF	Not lit	Drain pump Drain sensor	<ul style="list-style-type: none"> • Drain sensor is open. • Drain sensor detects abnormal water level. 	<ul style="list-style-type: none"> • Check the drain sensor and the drain pump. • Check the connectors of drain sensor and the drain pump. • Refer to 11-6. ㉔ "Check of drain sensor and drain pump".
11-time blink 2.5-second OFF	Not lit	Indoor fan motor	When the rotational frequency feedback signal is not emitted during 12 seconds the indoor fan operation.	Refer to 11-6. ㉔ "Check of indoor fan motor".
12-time blink 2.5-second OFF	Not lit	Indoor control system	When it cannot properly read data in the nonvolatile memory of the indoor electronic control P.C. board.	Replace the indoor electronic control P.C. board.

11-3. INSTRUCTION OF TROUBLESHOOTING

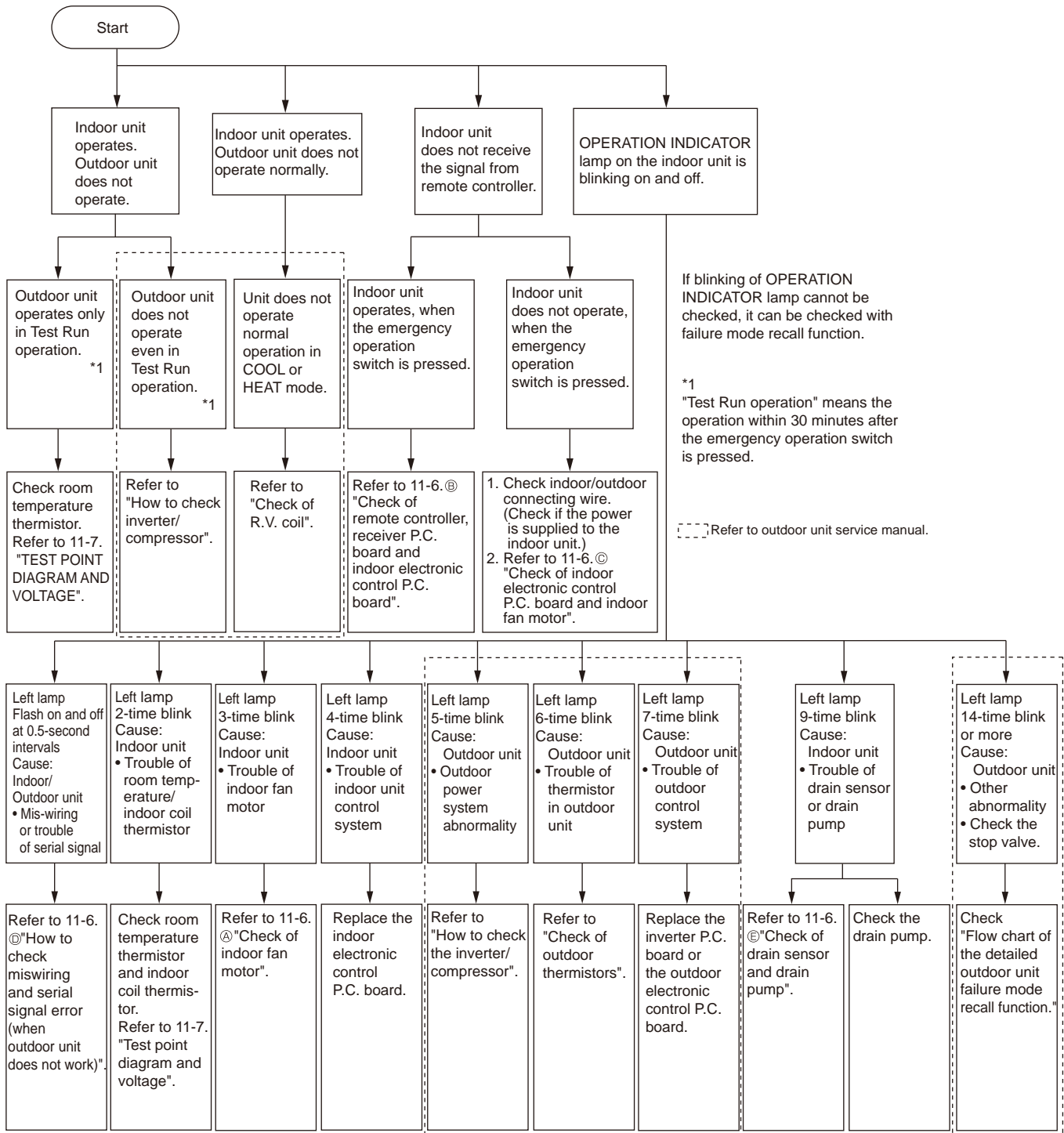

11-4. TROUBLESHOOTING CHECK TABLE

OPERATION INDICATOR



Lit

Blinking

Not lit

· Blinking of OPERATION INDICATOR lamp (left-hand side lamp) indicates abnormalities.

NOTE: Before taking measures, make sure that the symptom reappears for accurate troubleshooting.

Self check table

No.	Abnormal point	Operation indicator lamp	Symptom	Condition	Remedy
1	Miswiring or serial signal	Left lamp blinks. 0.5-second ON 0.5-second OFF	Indoor unit and outdoor unit do not operate.	When the serial signal from the outdoor unit is not received for a maximum of 6 minutes.	• Refer to 11-6.③ "How to check miswiring and serial signal error".
2	Indoor coil thermistor Room temperature thermistor	Left lamp blinks. 2-time blink 2.5-second OFF	Indoor unit and outdoor unit do not operate.	When the indoor coil or the room temperature thermistor is shorts or opens circuit.	• Refer to the characteristics of indoor coil thermistor, and the room temperature thermistor on 11-7.
3	Indoor fan motor	Left lamp blinks. 3-time blink 2.5-second OFF	Indoor unit and outdoor unit do not operate.	When the rotational frequency feedback signal is not emitted during the indoor fan operation.	• Refer to 11-6.④ "Check of indoor fan motor".
4	Indoor control system	Left lamp blinks. 4-time blink 2.5-second OFF	Indoor unit and outdoor unit do not operate.	When it cannot properly read data in the nonvolatile memory of the indoor electronic control P.C. board.	• Replace the indoor electronic control P.C. board.
5	Outdoor power system	Left lamp blinks. 5-time blink 2.5-second OFF	Indoor unit and outdoor unit do not operate.	The compressor stops 3 times consecutively for over current protection or start-up failure protection within 1 minute after start-up.	• Refer to "Check of inverter/compressor". • Check the stop valve. Refer to outdoor unit service manual.
6	Outdoor thermistors	Left lamp blinks. 6-time blink 2.5-second OFF	Indoor unit and outdoor unit do not operate.	When the outdoor thermistors short or open circuit during the compressor operation.	• Refer to "Check of outdoor thermistor". Refer to outdoor unit service manual.
7	Outdoor control system	Left lamp blinks. 7-time blink 2.5-second OFF	Indoor unit and outdoor unit do not operate.	When it cannot properly read data in the nonvolatile memory of the inverter P.C. board or the outdoor electronic control P.C. board.	• Replace the inverter P.C. board or the outdoor electronic control P.C. board. Refer to outdoor unit service manual.
8	Drain pump	Left lamp blinks. 9-time blink 2.5-second OFF	Indoor unit and outdoor unit do not operate.	<ul style="list-style-type: none"> • Drain sensor is open. • Drain sensor detects abnormal water level. 	<ul style="list-style-type: none"> • Check the drain sensor characteristics. • Check the drain pump. • Check the drain pipe. • Check the connectors of drain sensor and the drain pump. • Refer to 11-6.⑤ "Check of drain sensor and drain pump".
9	Other abnormality	Left lamp blinks. 14-time blink or more 2.5-second OFF	Indoor unit and outdoor unit do not operate.	An abnormality other than above mentioned is detected.	• Check the abnormality in detail using the failure mode recall function. Refer to outdoor unit service manual.

NOTE: When the indoor unit has started operation and the above failures are detected (the first detection after the power ON), the indoor electronic control P.C. board turns OFF the indoor fan motor with OPERATION INDICATOR lamp blinking.

OPERATION INDICATOR

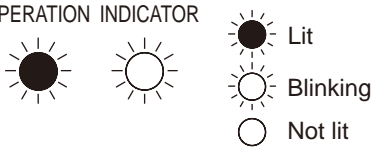

- Blinking of OPERATION INDICATOR lamp (right-hand side lamp) indicates abnormality.
- OPERATION INDICATOR lamp (left-hand side lamp) is lighted.

No.	Abnormal point	Operation indicator lamp	Symptom	Condition	Remedy
1	MXZ type Operation mode setting	<p>Right lamp blink</p> <p>2.5-second OFF</p>	Outdoor unit operates but indoor unit does not operate.	When the operation mode of the each indoor unit is differently set to COOL (includes DRY) and HEAT at the same time, the operation mode of the indoor unit that has operated at first has the priority.	<ul style="list-style-type: none"> • Unify the operation mode. Refer to outdoor unit service manual.

NOTE: When the indoor unit has started operation and the above failures are detected (the first detection after the power ON), the indoor electronic control P.C. board turns OFF the indoor fan motor with OPERATION INDICATOR lamp blinking.

11-5. TROUBLESHOOTING CRITERION MLZ-KY20VG

Part name	Check method and criteria	Figure								
Room temperature thermistor (RT11)	Measure the resistance with a multimeter. (Part temperature 10°C - 30°C)	/								
Indoor coil thermistor (RT12 (MAIN), RT13 (SUB))	<table border="1" style="margin-left: auto; margin-right: auto;"> <tr> <td>Normal</td> </tr> <tr> <td>8 kΩ - 20 kΩ</td> </tr> </table>		Normal	8 kΩ - 20 kΩ						
Normal										
8 kΩ - 20 kΩ										
Indoor fan motor	Check 11-6. ㉔.	/								
Drain sensor (DS)	Disconnect the connectors and measure the resistance between the terminals with a multimeter. (Part temperature 10°C - 30°C) <table border="1" style="margin-left: auto; margin-right: auto;"> <thead> <tr> <th>Terminal (CN1M1)</th> <th>Normal</th> <th>Abnormal</th> </tr> </thead> <tbody> <tr> <td>BLK①-BLK③(heater)</td> <td>About 80Ω</td> <td rowspan="2">Open or short</td> </tr> <tr> <td>BLK④-BLK⑤(thermistor)</td> <td>4kΩ - 10kΩ</td> </tr> </tbody> </table> <p>NOTE: The relay connectors are connected near the drain sensor. (Refer to characteristic graph 11-7.)</p>	Terminal (CN1M1)	Normal	Abnormal	BLK①-BLK③(heater)	About 80Ω	Open or short	BLK④-BLK⑤(thermistor)	4kΩ - 10kΩ	/
Terminal (CN1M1)	Normal	Abnormal								
BLK①-BLK③(heater)	About 80Ω	Open or short								
BLK④-BLK⑤(thermistor)	4kΩ - 10kΩ									
Drain pump (DP)	Measure the resistance between the terminals with a multimeter. (Part temperature 10°C - 30°C) <table border="1" style="margin-left: auto; margin-right: auto;"> <thead> <tr> <th>Color of the lead wire</th> <th>Normal</th> </tr> </thead> <tbody> <tr> <td>BLUE-BLUE (Drain pump side)</td> <td rowspan="2">520Ω - 620Ω</td> </tr> <tr> <td>RED-RED (Control P.C. board side)</td> </tr> </tbody> </table>	Color of the lead wire	Normal	BLUE-BLUE (Drain pump side)	520Ω - 620Ω	RED-RED (Control P.C. board side)	/			
Color of the lead wire	Normal									
BLUE-BLUE (Drain pump side)	520Ω - 620Ω									
RED-RED (Control P.C. board side)										
Horizontal vane motor (MV1)	Measure the resistance between the terminals with a multimeter. (Part temperature 20°C - 30°C) <table border="1" style="margin-left: auto; margin-right: auto;"> <thead> <tr> <th>Color of the lead wire</th> <th>Normal</th> </tr> </thead> <tbody> <tr> <td>RED-YLW</td> <td>Each phase 300Ω</td> </tr> </tbody> </table>	Color of the lead wire	Normal	RED-YLW	Each phase 300Ω					
Color of the lead wire	Normal									
RED-YLW	Each phase 300Ω									
Vertical vane motor (MV2)	Measure the resistance between the terminals with a multimeter. (Part temperature 20°C - 30°C) <table border="1" style="margin-left: auto; margin-right: auto;"> <thead> <tr> <th>Color of the lead wire</th> <th>Normal</th> </tr> </thead> <tbody> <tr> <td>RED-YLW</td> <td>Each phase 300Ω</td> </tr> </tbody> </table>	Color of the lead wire	Normal	RED-YLW	Each phase 300Ω					
Color of the lead wire	Normal									
RED-YLW	Each phase 300Ω									

11-6. TROUBLESHOOTING FLOW

When the left lamp of OPERATION INDICATOR lamp blinks 3 times and the right lamp of OPERATION INDICATOR lamp is not lighted.
Indoor fan does not operate.

A Check of indoor fan motor

The indoor fan motor error has occurred, and the indoor fan does not operate.

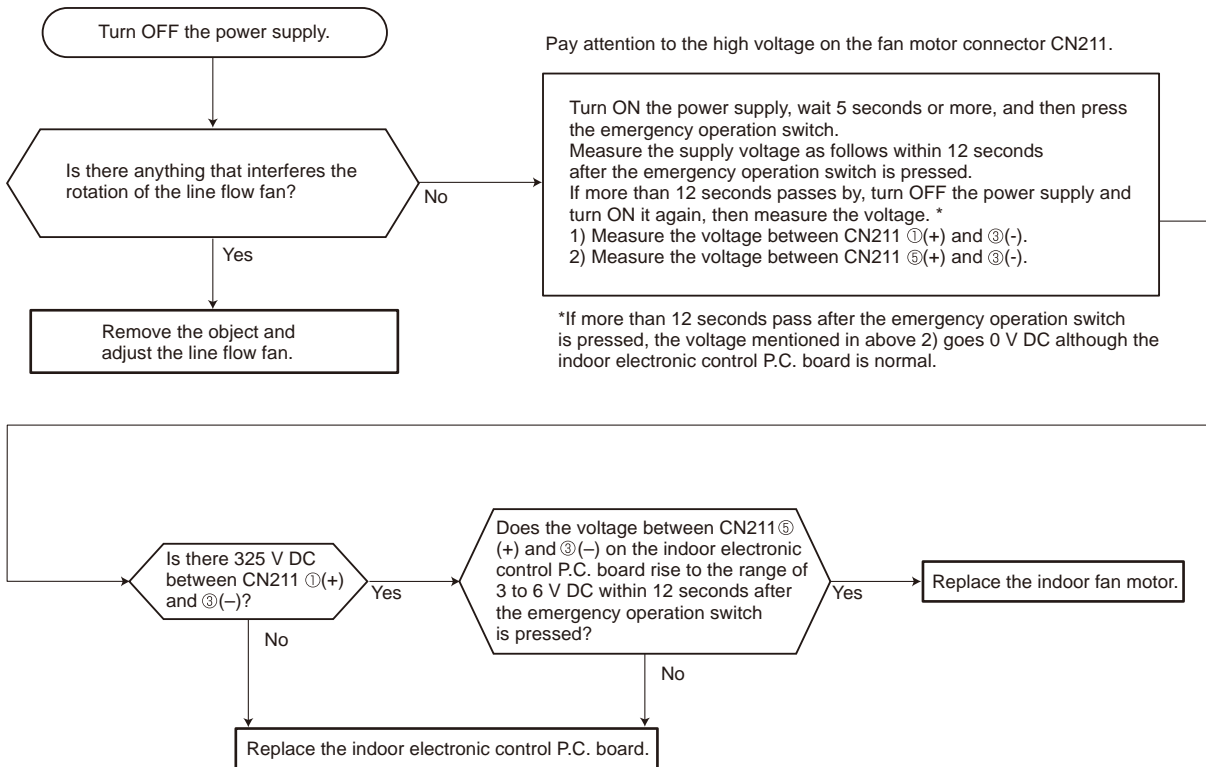

The indoor fan motor error has occurred, and the indoor fan repeats "12-second ON and 30-second OFF" 3 times, and then stops.

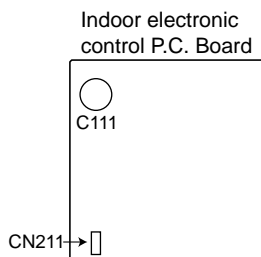
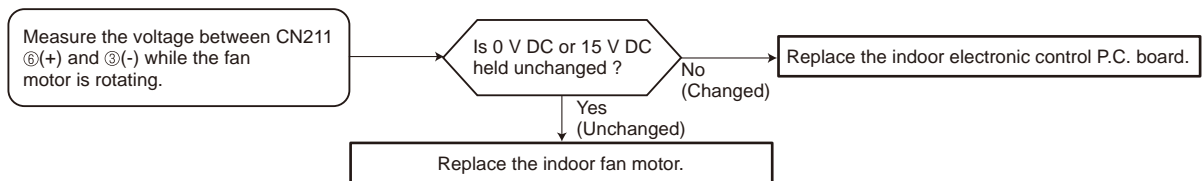

Indoor unit operates by pressing the emergency operation switch, but does not operate with the remote controller.

B Check of remote controller, receiver P.C. board and indoor electronic control P.C. board

* Check if the remote controller is exclusive for this air conditioner.

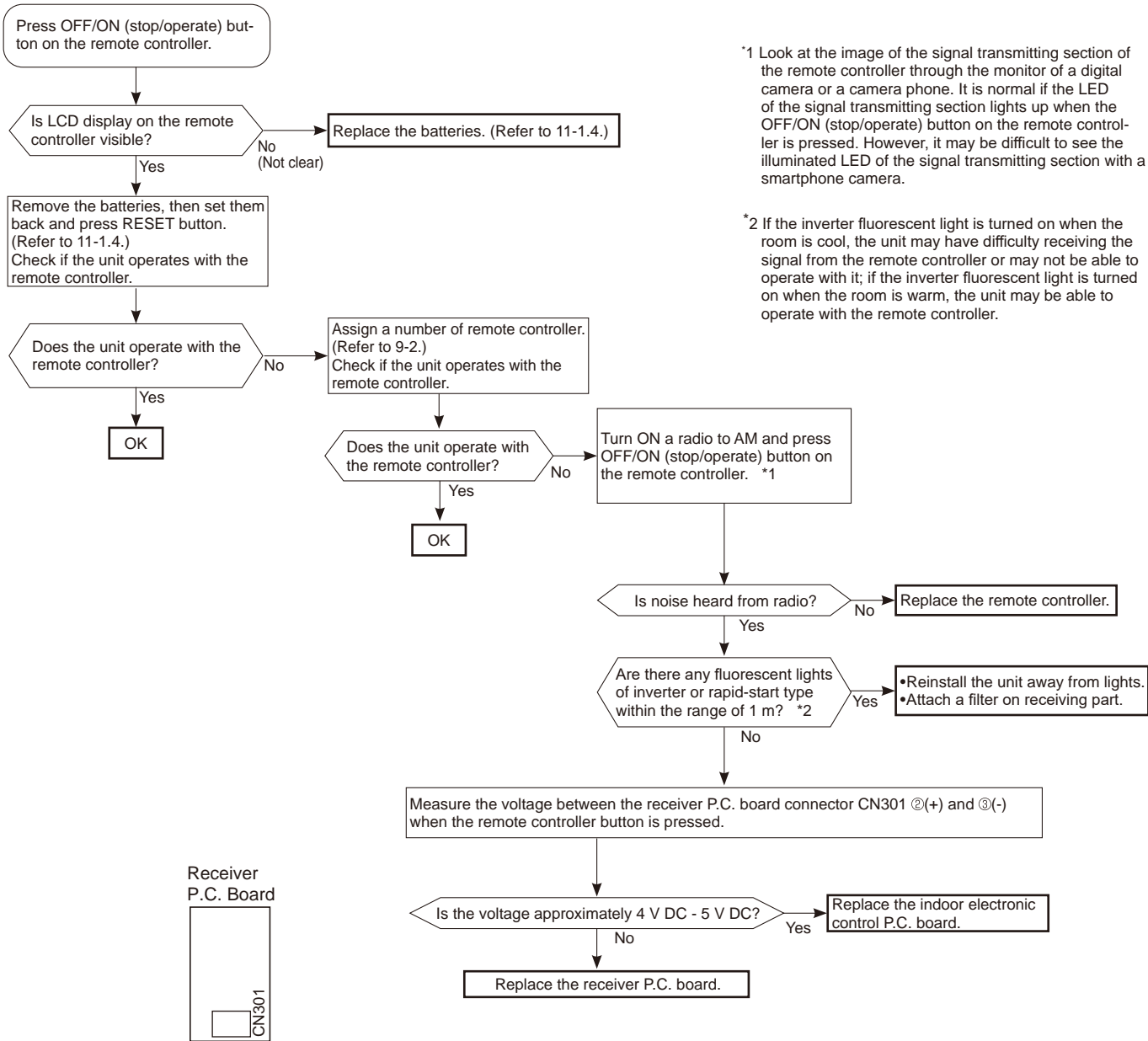

*1 Look at the image of the signal transmitting section of the remote controller through the monitor of a digital camera or a camera phone. It is normal if the LED of the signal transmitting section lights up when the OFF/ON (stop/operate) button on the remote controller is pressed. However, it may be difficult to see the illuminated LED of the signal transmitting section with a smartphone camera.

*2 If the inverter fluorescent light is turned on when the room is cool, the unit may have difficulty receiving the signal from the remote controller or may not be able to operate with it; if the inverter fluorescent light is turned on when the room is warm, the unit may be able to operate with the remote controller.

The unit cannot be operated with the remote controller.
 Also, OPERATION INDICATOR lamp does not light up by pressing the emergency operation switch.

Ⓒ Check of indoor electronic control P.C. board and indoor fan motor

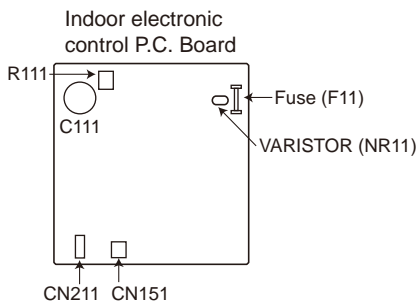
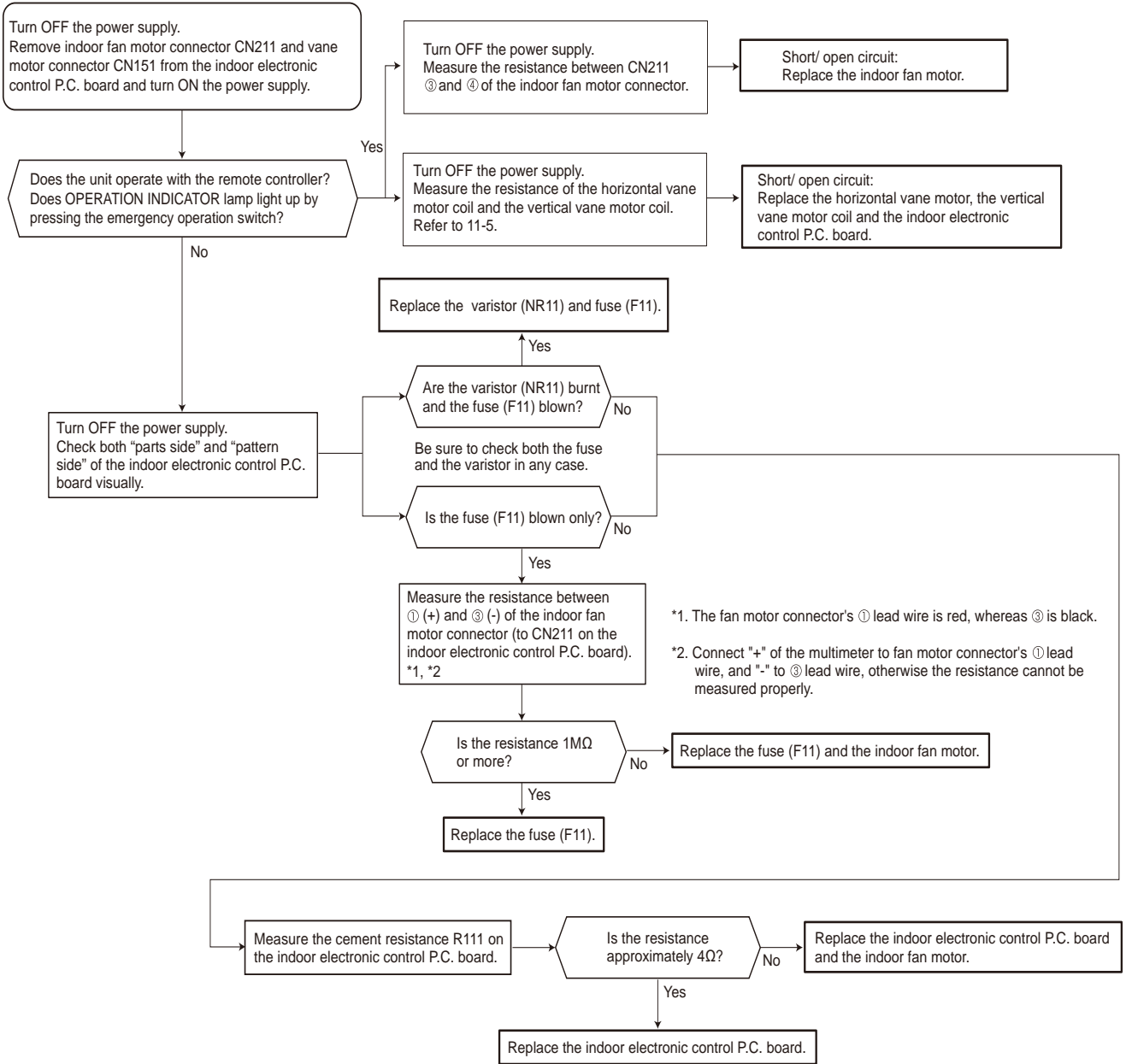

When the left lamp of OPERATION INDICATOR lamp blinks ON and OFF in every 0.5-second.
Outdoor unit does not operate.

D How to check miswiring and serial signal error

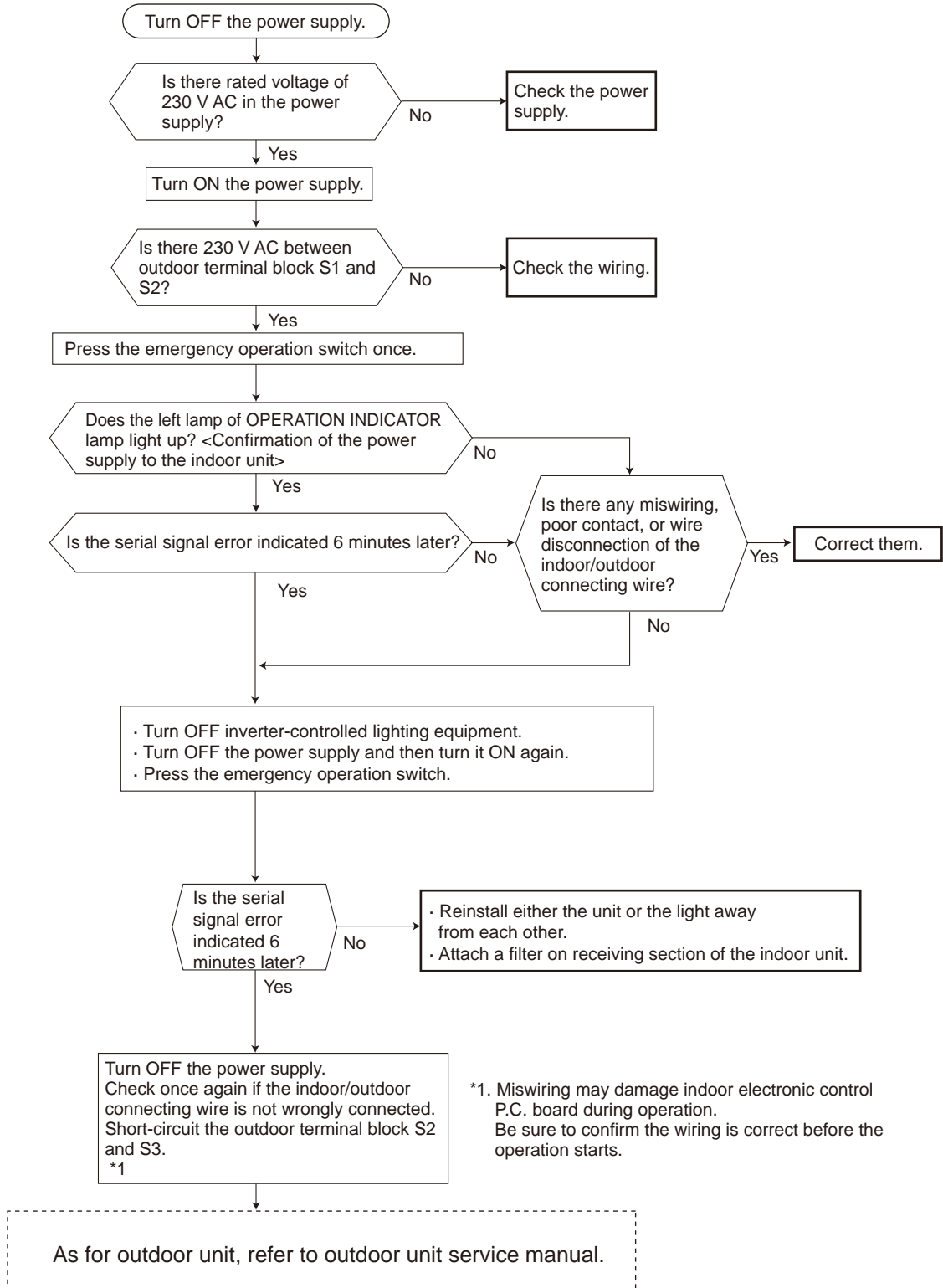

When the left lamp of OPERATION INDICATOR lamp blinks 9-time.
Indoor unit and outdoor unit do not operate.

E Check of drain sensor and drain pump

The drain sensor error has occurred.

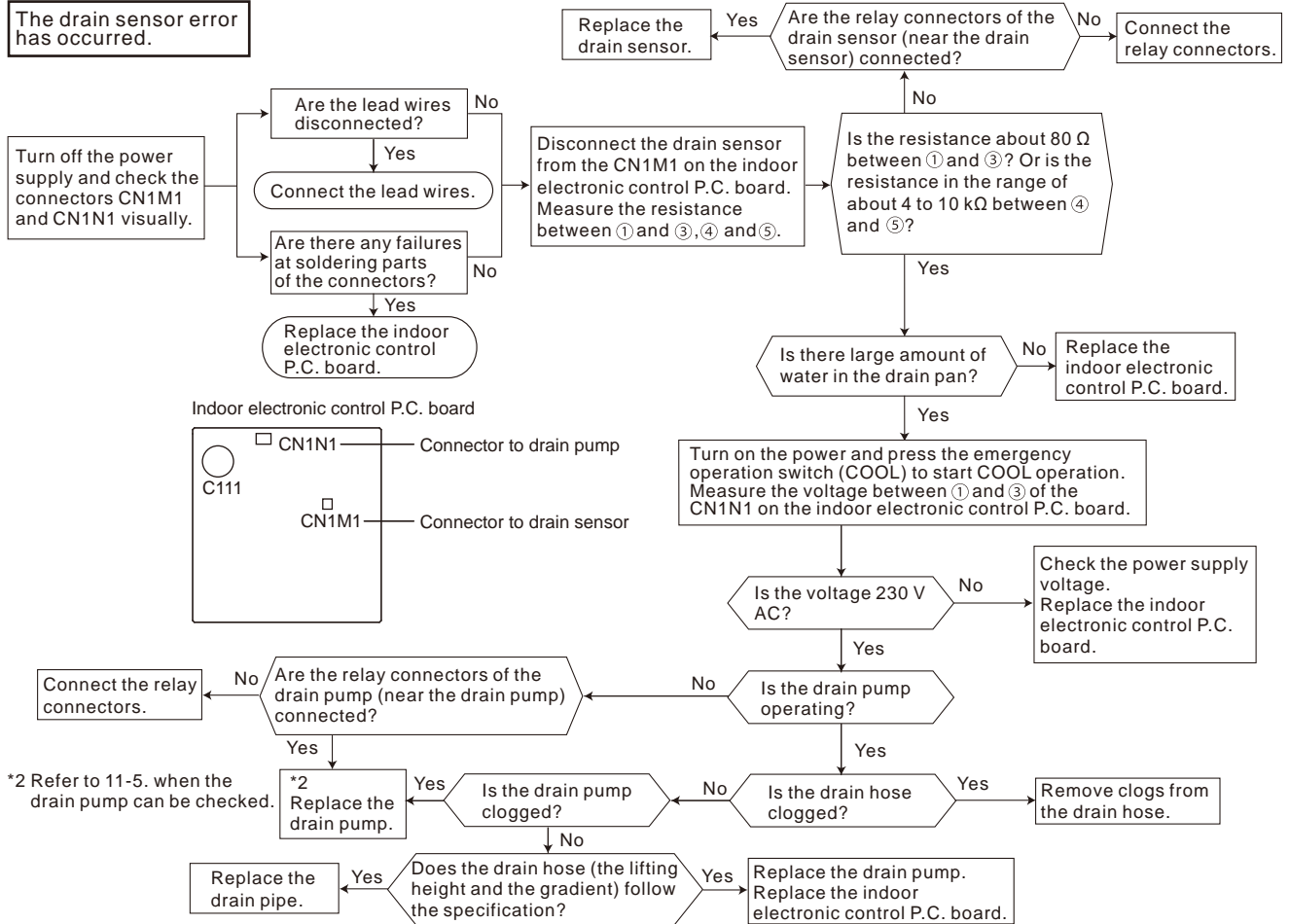

F Electromagnetic noise enters into TV sets or radios

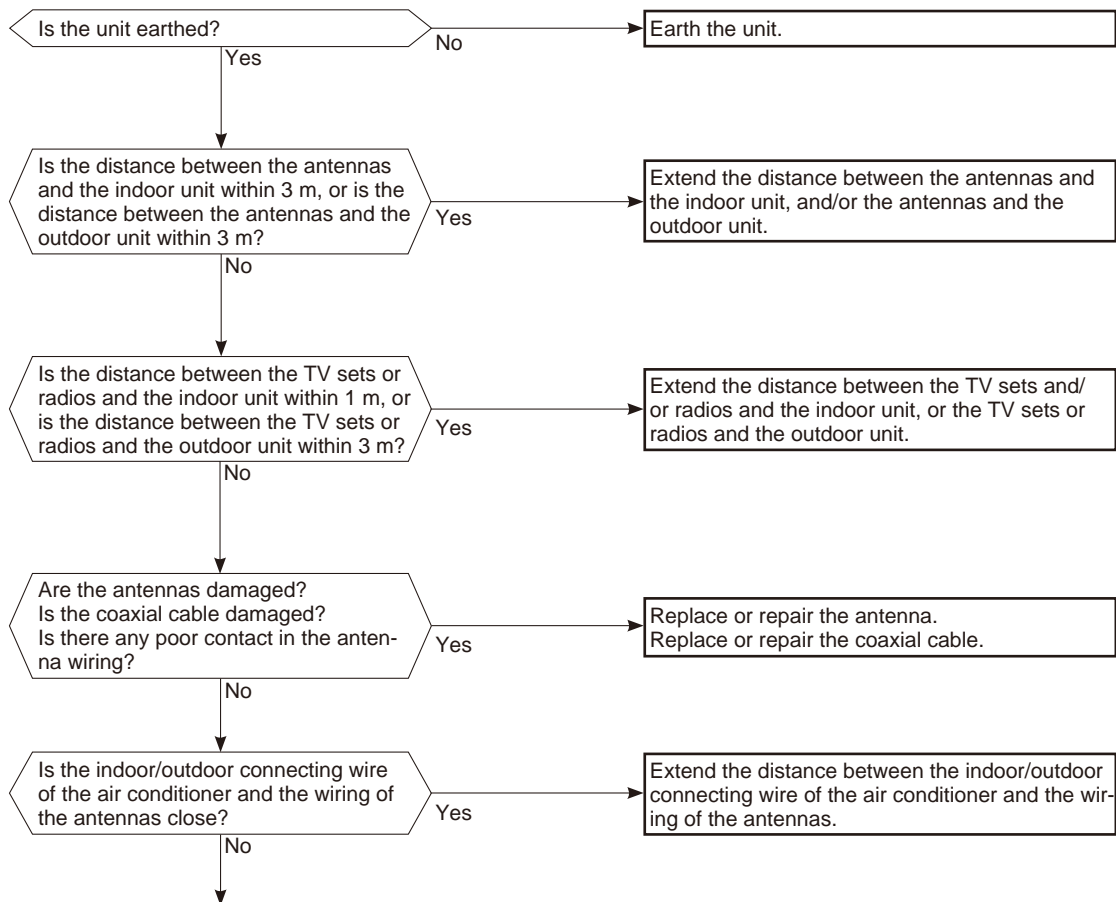

Even if all of the above conditions are fulfilled, the electromagnetic noise may enter, depending on the electric field strength or the installation condition (combination of specific conditions such as antennas or wiring).

Check the following before asking for service.

1. Devices affected by the electromagnetic noise
TV sets, radios (FM/AM broadcast, shortwave)
2. Channel, frequency, broadcast station affected by the electromagnetic noise
3. Channel, frequency, broadcast station unaffected by the electromagnetic noise
4. Layout of:
indoor/outdoor unit of the air conditioner, indoor/outdoor wiring, earth wire, antennas, wiring from antennas, receiver
5. Electric field intensity of the broadcast station affected by the electromagnetic noise
6. Presence or absence of amplifier such as booster
7. Operation condition of air conditioner when the electromagnetic noise enters in
 - 1) Turn OFF the power supply once, and then turn ON the power supply. In this situation, check for the electromagnetic noise.
 - 2) Within 3 minutes after turning ON the power supply, press OFF/ON (stop/operate) button on the remote controller for power ON, and check for the electromagnetic noise.
 - 3) After a short time (3 minutes later after turning ON), the outdoor unit starts running. During operation, check for the electromagnetic noise.
 - 4) Press OFF/ON (stop/operate) button on the remote controller for power OFF, when the outdoor unit stops but the indoor/outdoor communication still runs on. In this situation, check for the electromagnetic noise.

11-7. TEST POINT DIAGRAM AND VOLTAGE

MLZ-KY20VG Indoor electronic control P.C. board

Factory setting
(Do not change the setting.)

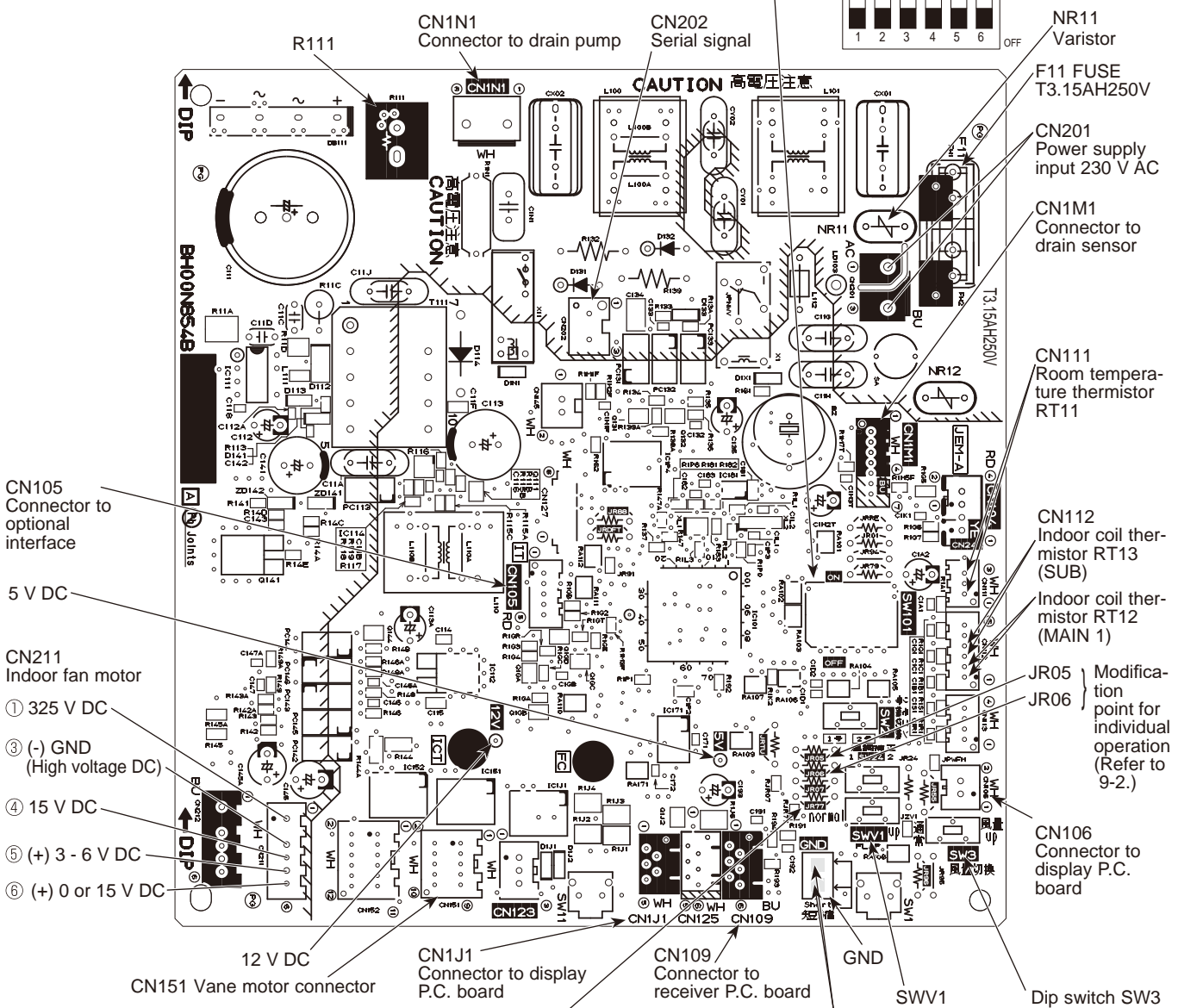
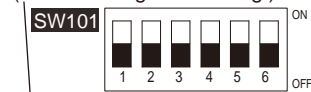

Receiver P.C. board

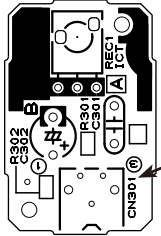

Display P.C. board

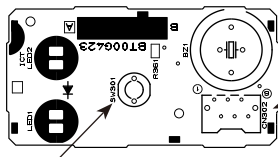

To disable "Auto restart function", cut the Jumper wire to JR77. (Refer to 9-3.)

Timer short mode point (2 points) (Refer to 9-1.)

Indoor coil thermistor [RT12 (MAIN), RT13 (SUB)]
Room temperature thermistor (RT11)

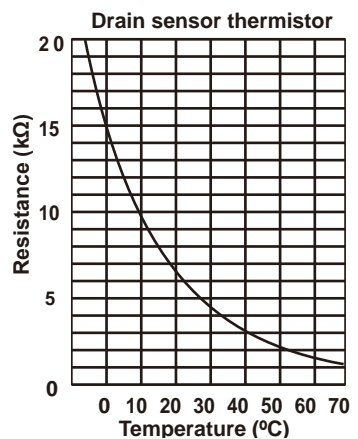
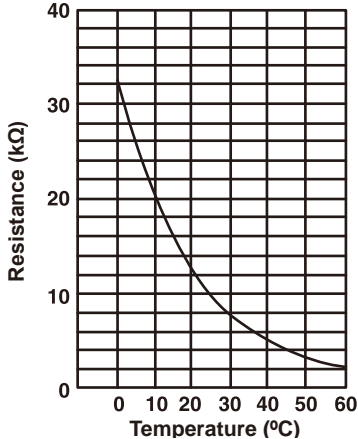

<Detaching method of the terminal with locking mechanism>

The terminal which has the locking mechanism can be detached as shown below.
 There are 2 types of the terminal with locking mechanism.
 The terminal without locking mechanism can be detached by pulling it out.
 Check the shape of the terminal before detaching.

(1) Slide the sleeve and check if there is a locking lever or not.

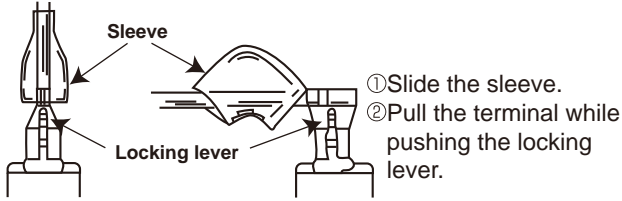

(2) The terminal with the connector shown below has the locking mechanism.

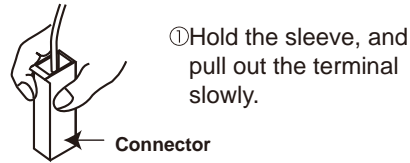

MLZ-KY20VG

NOTE: Turn OFF the power supply before disassembly.

→ : Indicates the visible parts in the photos/figures.
 ---→ : Indicates the invisible parts in the photos/figures.

OPERATING PROCEDURE	PHOTOS/FIGURES
<p>1. Removing the intake grille</p> <p>(1) Slide the tabs (2 places) of intake grille in the direction of the arrow (Figure 1).</p> <p>(2) Hold the intake grille and pull it down to open (Figure 2).</p> <p>(3) Slide the grille shafts (1 each on the left and right sides) off the intake grille and remove the intake grille (Figure 3).</p> <p>(4) Remove the safety strings of intake grille from the hooks (Figure 4).</p>	<p>Photo 1</p> <p>Remote control receiving section</p> <p>Places for installing the air cleaning filters or V blocking filters [(Silver-ionized air purifier filters (option)) [Install to air filters.(Air purifying filter)]</p> <p>Horizontal vane</p> <p>Electrical parts</p> <p>Safety string</p> <p>Safety string</p> <p>Intake grille</p> <p>Places for installing the air filter(Air purifying filter)</p> <p>Figure 1</p> <p>Intake grille</p> <p>Tab</p> <p>Press</p> <p>Figure 2</p> <p>Figure 3</p> <p>Shaft</p> <p>Slide inward.</p> <p>Figure 4</p> <p>Safety string</p> <p>Hook</p>

OPERATING PROCEDURE

2. Removing the grille

- (1) Remove the intake grille.
- (2) Remove the fixing screws for side panels (2 screws) on the left and right sides (Figure 5).
- (3) Open the side panels on the left and right sides. Remove the safety strings from the grille and remove the side panels (Figure 5).
- (4) Open the horizontal vane completely.
- (5) Remove the screw cap in the center of air outlet (Figure 5).
- (6) Remove the fixing screws ① at 4 places on the left and right sides (Figure 6).
- (7) Remove the fixing screws ① at 2 places in the middle and the fixing screw ② in the center (Figure 6).
- (8) Remove the temporary holding tabs of the grille from the hooks of the indoor unit (Figure 6).

<Installing the grille>

- (1) Open the horizontal vane completely.
- (2) Remove the screw cap in the center of air outlet (Figure 5).
- (3) Attach the temporary holding tabs of the grille to the hooks of the indoor unit (Figure 6).
- (4) Place the grille so that it fits closely with the ceiling surface. Loosely fasten with the provided fixing screws ① at 4 places on the left and right side (Figure 6).
- (5) Tighten the fixing screws ① at 2 places in the middle and the fixing screw ② in the center (Figure 6).
- (6) Tighten the fixing screws ① at 4 places on the left and right sides.

NOTE: Make sure there are no gaps between the indoor unit and the grille, or between the grille and the ceiling surface. If there are any gaps, the wind may come in and it may cause water to drip (Figure 7).

NOTE: Tighten the fixing screws ① and ② completely (Figure 6).

NOTE: If there are any gaps between the grille and the ceiling, with the grille attached, slightly adjust the installation height of the unit and clear the gap (Figure 8).

PHOTOS/FIGURES

Figure 5

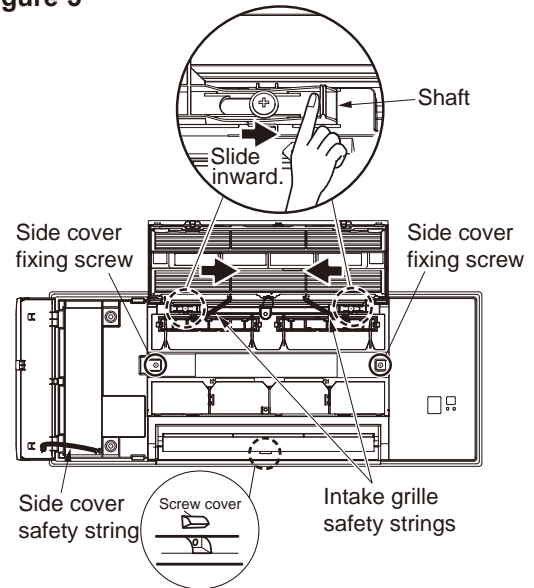

Figure 6

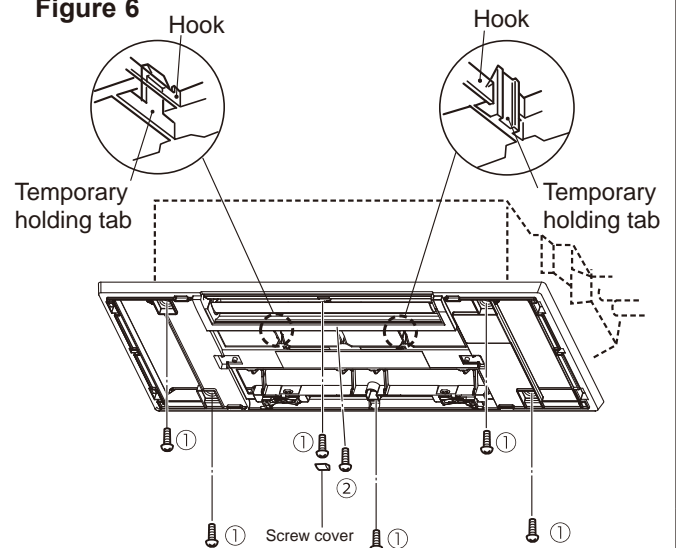

Figure 7

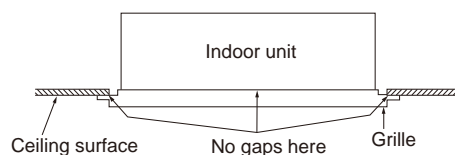
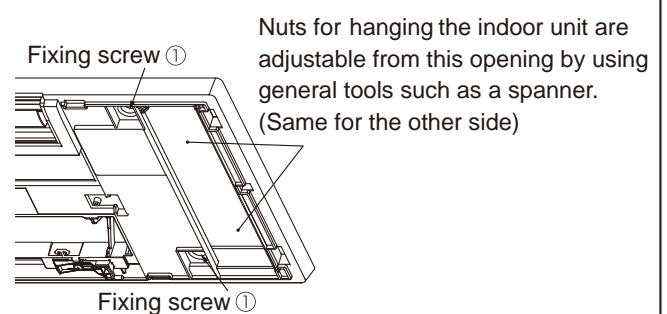

Figure 8



OPERATING PROCEDURE

- (7) Install the screw cap.
- (8) After attaching the safety strings for the left and right side panels to the grille, install the side panels (Figure 9).

NOTE: Make sure that the tabs of the side panels securely fit into place (Figure 9).

NOTE: Open the display cover to make sure the positioning marks are aligned.

NOTE: Make sure that there are no gaps between the emergency operation switch and the side panel (Figure 10).

NOTE: Make sure that the safety strings do not hang out of the side panels.

- (9) Attach the air cleaning filters (V Blocking Filters), if any, to the catches on the air filters (Air purifier filters) (Figure 10).

- (10) Attach the safety strings for intake grille to the grille and insert the grille shafts into the holes of the intake grille (Figure 10).

- (11) Close the intake grille (Figure 11).

NOTE: Press the intake grille firmly against the grille until a click is heard from each tab on the left and right sides.

PHOTOS/FIGURES

Figure 9

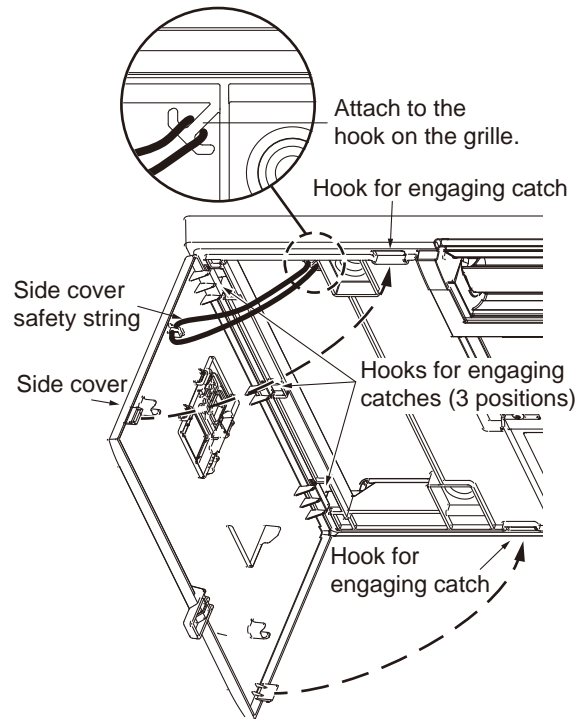
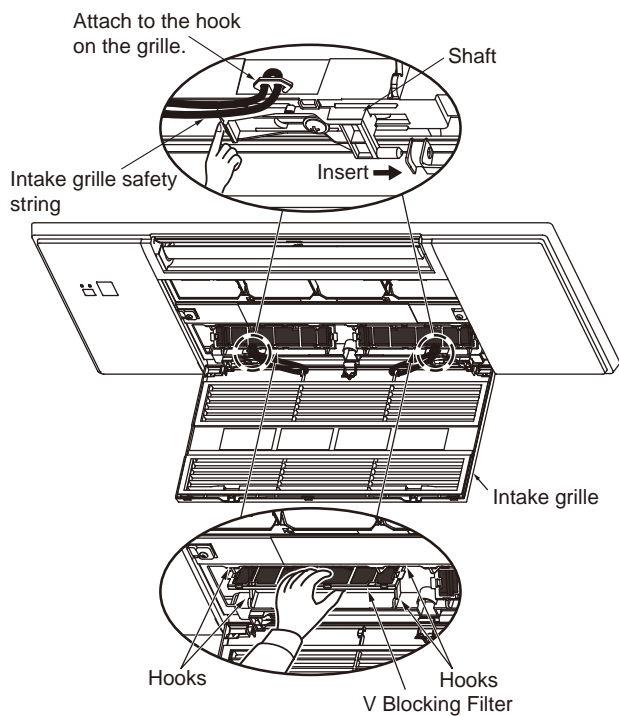

Figure 10



<Check after installing>

- (1) Check that there are no gaps between the indoor unit and the grille, or between the grille and the ceiling surface.

NOTE: If there are any gaps, the wind may come in and it may cause water to drip.

- (2) Check that the screw cap is installed.
 - (3) Check that the left and right side panels are installed securely.
 - (4) Check that the emergency operation switch is installed securely.
 - (5) Check that the display cover of side panel is installed securely.
 - (6) Check that the filters are installed securely.
- NOTE:** If the filters are not installed securely, the intake grille may not close properly.
- (7) Check that the safety strings (4 places) are attached securely.

Figure 11

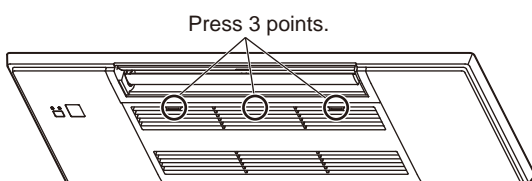

OPERATING PROCEDURE

3. Removing the indoor electric control P.C. board, the receiver P.C. board and the display P.C. board

- (1) Remove the intake grille.
- (2) Remove the side panel (L).
- (3) Remove screw of the lampcover and Pull out a cover to the direction of an arrow. (Photo 2).
- (4) Remove the electrical cover (A) (Photo 2).
- (5) Partially slide the indoor electronic control P.C. board out.
- (6) Disconnect all the connectors and lead wires on the board to remove the indoor electric control P.C. board.
- (7) Disconnect the connectors and lead wires, and remove the receiver P.C. board and the display P.C. board.

4. Removing the heat exchanger and stabilizer

- (1) Remove the grille.
- (2) Remove the tabs (2 places) in the center of stabilizer and remove the drain pan (4 fixing screws).
- (3) Remove the electrical cover (A).
- (4) Disconnect the connectors of the horizontal and vertical vane motors.
- (5) Remove the indoor coil thermistors (main and sub).
- (6) Remove the drain cover (3 fixing screws).
- (7) Remove the pipe band.
- (8) Remove the heat exchanger (6 fixing screws).
- (9) Remove the stabilizer (2 fixing screws).

5. Removing the horizontal and vertical vane motors

- (1) Remove the grille.
- (2) Remove the drain pan.
- (3) Remove the horizontal vane.
- (4) Remove the heat exchanger and stabilizer.
- (5) Remove the cover of horizontal and vertical vane motors (2 fixing screws).
- (6) Remove the vertical vane motor (2 fixing screws) and disconnect the connector (Photo 4).
- (7) Remove the horizontal vane motor (2 fixing screws) and disconnect the connector (Photo 4).

PHOTOS/FIGURES

Photo 2

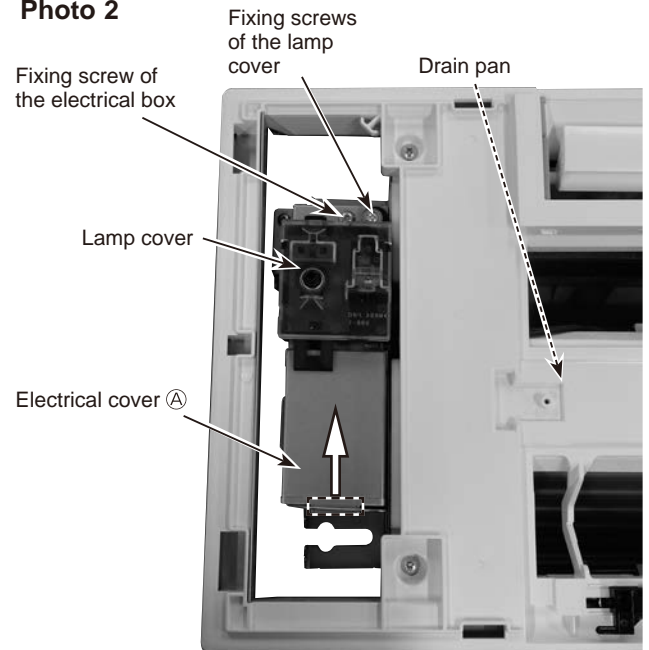

Photo 3

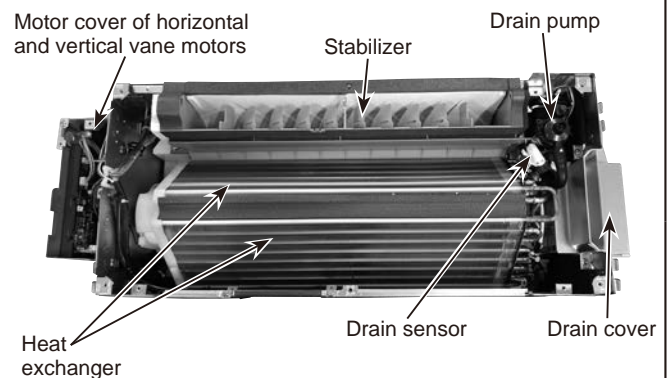
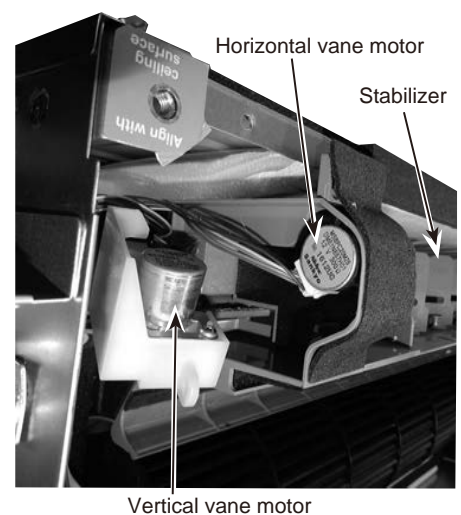
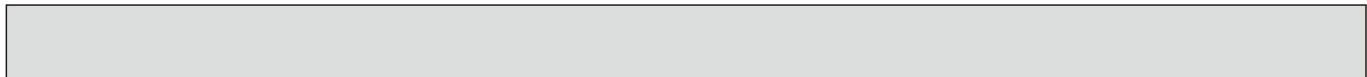
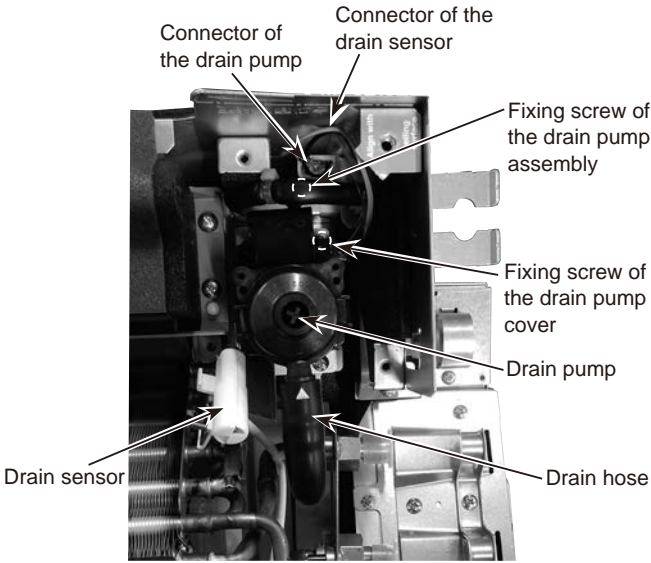
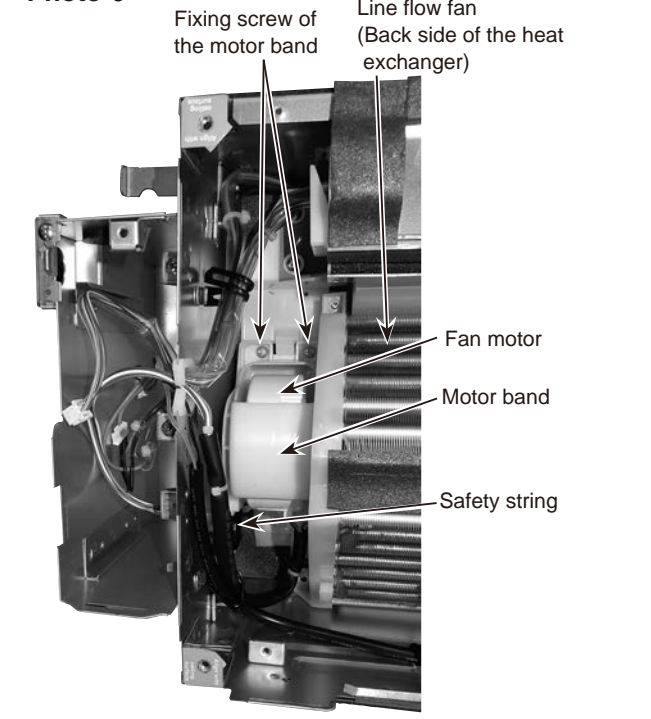

Photo 4





OPERATING PROCEDURE	PHOTOS/FIGURES
<p>6. Removing the drain pump and drain sensor</p> <ol style="list-style-type: none">(1) Remove the grille.(2) Remove the drain pan.(3) Disconnect the connector of the drain pump (Photo 5).(4) Disconnect the connector of the drain sensor (Photo 5).(5) Remove the drain hose (Photo 5).(6) Remove the drain pump assembly (2 fixing screws) (Photo 5).(7) Remove the drain pump cover (2 fixing screws) (Photo 5).	<p>Photo 5</p>  <p>Labels in Photo 5: Connector of the drain pump Connector of the drain sensor Fixing screw of the drain pump assembly Fixing screw of the drain pump cover Drain pump Drain sensor Drain hose</p>
<p>7. Removing the fan motor and line flow fan</p> <ol style="list-style-type: none">(1) Remove the grille.(2) Remove the drain pan.(3) Remove the drain cover.(4) Remove the pipe band.(5) Remove the electrical cover (A).(6) Remove the terminal box.(7) Remove the safety string from the clamps and untie (Photo 6).(8) Hook the safety string to the tabs on the side plate of indoor heat exchanger.(9) Remove the indoor heat exchanger (6 fixing screws) and slide it downward.(10) Remove the stabilizer (2 fixing screws).(11) Partially slide the indoor electric control P.C. board out.(12) Disconnect the connector (CN211) of indoor fan motor.(13) Remove the motor band (2 fixing screws) (Figure 6).(14) Remove the indoor fan motor and line flow fan. (No need to remove the indoor heat exchanger to remove these 2 items.)	<p>Photo 6</p>  <p>Labels in Photo 6: Fixing screw of the motor band Line flow fan (Back side of the heat exchanger) Fan motor Motor band Safety string</p>

MITSUBISHI ELECTRIC CORPORATION

HEAD OFFICE: TOKYO BUILDING, 2-7-3, MARUNOUCHI, CHIYODA-KU, TOKYO 100-8310, JAPAN

© Copyright 2022 MITSUBISHI ELECTRIC CORPORATION
Published in Apr. 2022. No. OBH921
Made in Japan

Specifications are subject to change without notice.