

SERVICE PARTS LIST FOR MITSUBISHI ELECTRIC PACKAGED AIR-CONDITIONERS

Series : PUHY-EP·Y(S)NW-A2.TH(-BS)

For use with the R410A

Mar. 2022

BWE021560

INDEX

PUHY-EP200YNW-A2.TH
PUHY-EP200YNW-A2.TH-BS
PUHY-EP250YNW-A2.TH
PUHY-EP250YNW-A2.TH-BS
PUHY-EP300YNW-A2.TH
PUHY-EP300YNW-A2.TH-BS
PUHY-EP350YNW-A2.TH
PUHY-EP350YNW-A2.TH-BS
PUHY-EP400YNW-A2.TH
PUHY-EP400YNW-A2.TH-BS
PUHY-EP450YNW-A2.TH
PUHY-EP450YNW-A2.TH-BS
PUHY-EP500YNW-A2.TH
PUHY-EP500YNW-A2.TH-BS

The Package name list

PUHY-EP400YSNW-A2(-BS) [PUHY-EP200YNW-A2.TH(-BS)+PUHY-EP200YNW-A2.TH(-BS)]

PUHY-EP450YSNW-A2(-BS) [PUHY-EP200YNW-A2.TH(-BS)+PUHY-EP250YNW-A2.TH(-BS)]

PUHY-EP500YSNW-A2(-BS) [PUHY-EP250YNW-A2.TH(-BS)+PUHY-EP250YNW-A2.TH(-BS)]

PUHY-EP550YSNW-A2(-BS) [PUHY-EP250YNW-A2.TH(-BS)+PUHY-EP300YNW-A2.TH(-BS)]

PUHY-EP600YSNW-A2(-BS) [PUHY-EP300YNW-A2.TH(-BS)+PUHY-EP300YNW-A2.TH(-BS)]

PUHY-EP650YSNW-A2(-BS) [PUHY-EP250YNW-A2.TH(-BS)+PUHY-EP400YNW-A2.TH(-BS)]

PUHY-EP700YSNW-A2(-BS) [PUHY-EP350YNW-A2.TH(-BS)+PUHY-EP350YNW-A2.TH(-BS)]

PUHY-EP750YSNW-A2(-BS) [PUHY-EP350YNW-A2.TH(-BS)+PUHY-EP400YNW-A2.TH(-BS)]

PUHY-EP800YSNW-A2(-BS) [PUHY-EP350YNW-A2.TH(-BS)+PUHY-EP450YNW-A2.TH(-BS)]

PUHY-EP850YSNW-A2(-BS) [PUHY-EP400YNW-A2.TH(-BS)+PUHY-EP450YNW-A2.TH(-BS)]

PUHY-EP900YSNW-A2(-BS) [PUHY-EP450YNW-A2.TH(-BS)+PUHY-EP450YNW-A2.TH(-BS)]

PUHY-EP950YSNW-A2(-BS) [PUHY-EP250YNW-A2.TH(-BS)+PUHY-EP350YNW-A2.TH(-BS)+PUHY-EP350YNW-A2.TH(-BS)]

PUHY-EP1000YSNW-A2(-BS) [PUHY-EP250YNW-A2.TH(-BS)+PUHY-EP350YNW-A2.TH(-BS)+PUHY-EP400YNW-A2.TH(-BS)]

PUHY-EP1050YSNW-A2(-BS) [PUHY-EP250YNW-A2.TH(-BS)+PUHY-EP400YNW-A2.TH(-BS)+PUHY-EP400YNW-A2.TH(-BS)]

PUHY-EP1100YSNW-A2(-BS) [PUHY-EP350YNW-A2.TH(-BS)+PUHY-EP350YNW-A2.TH(-BS)+PUHY-EP400YNW-A2.TH(-BS)]

PUHY-EP1150YSNW-A2(-BS) [PUHY-EP350YNW-A2.TH(-BS)+PUHY-EP400YNW-A2.TH(-BS)+PUHY-EP400YNW-A2.TH(-BS)]

PUHY-EP1200YSNW-A2(-BS) [PUHY-EP400YNW-A2.TH(-BS)+PUHY-EP400YNW-A2.TH(-BS)+PUHY-EP400YNW-A2.TH(-BS)]

PUHY-EP1250YSNW-A2(-BS) [PUHY-EP400YNW-A2.TH(-BS)+PUHY-EP400YNW-A2.TH(-BS)+PUHY-EP450YNW-A2.TH(-BS)]

PUHY-EP1300YSNW-A2(-BS) [PUHY-EP400YNW-A2.TH(-BS)+PUHY-EP450YNW-A2.TH(-BS)+PUHY-EP450YNW-A2.TH(-BS)]

PUHY-EP1350YSNW-A2(-BS) [PUHY-EP450YNW-A2.TH(-BS)+PUHY-EP450YNW-A2.TH(-BS)+PUHY-EP450YNW-A2.TH(-BS)]

PUHY-EP200,EP250,EP300YNW-A2.TH
PUHY-EP200,EP250,EP300YNW-A2.TH-BS

EXTERNAL PARTS & BLOWER PARTS (1-1)

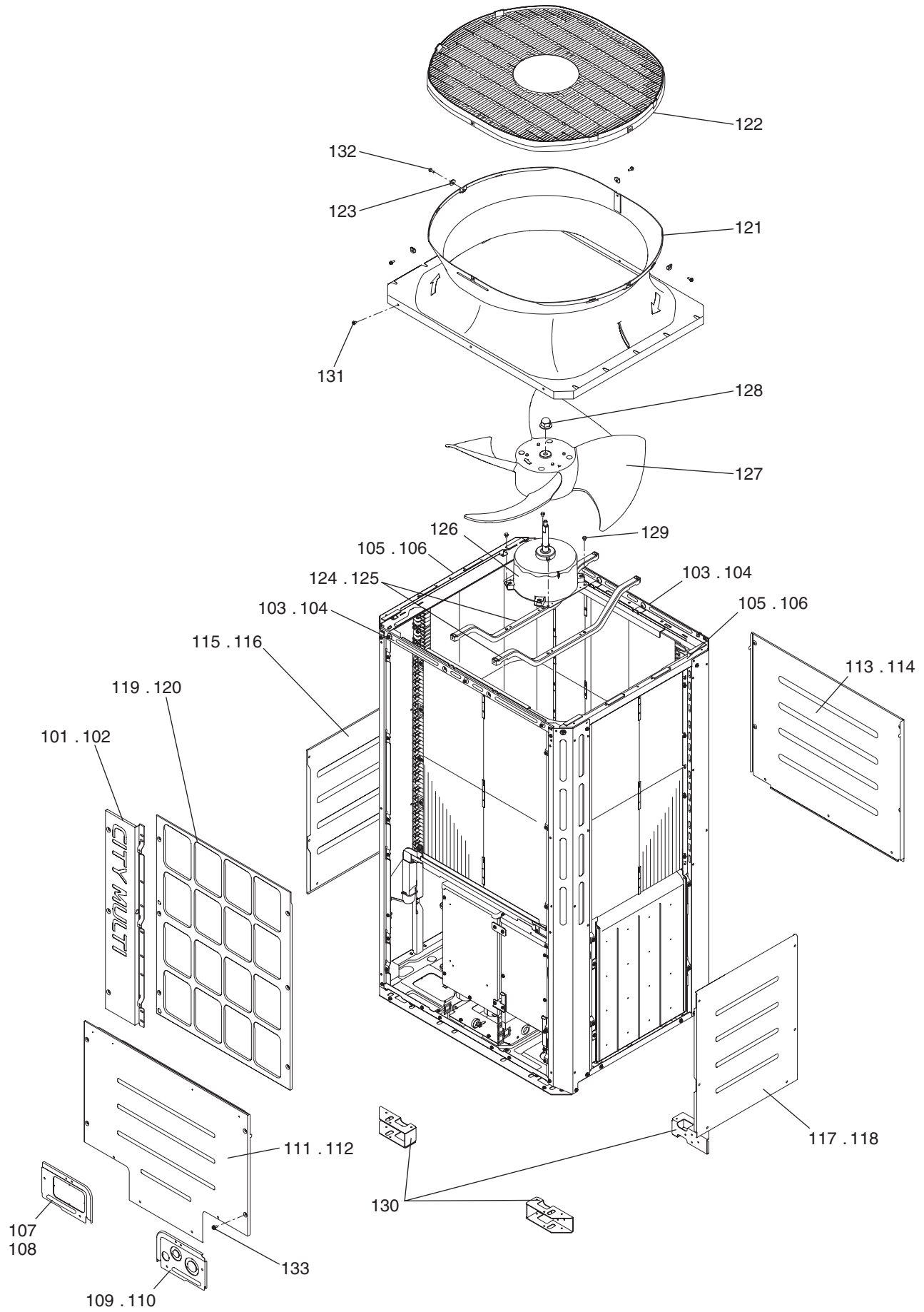

PUHY-EP200,EP250,EP300YNW-A2.TH
 PUHY-EP200,EP250,EP300YNW-A2.TH-BS

EXTERNAL PARTS & BLOWER PARTS (1-1)

No.	Part No.	Part Name	Spec.	PUHY-EP200/YNW-A2.TH	PUHY-EP250/YNW-A2.TH-BS	PUHY-EP250/YNW-A2.TH	PUHY-EP250/YNW-A2.TH-BS	PUHY-EP300/YNW-A2.TH	PUHY-EP300/YNW-A2.TH-BS	Dwg. No.	Notes for the models	Revision info.
101	E27 J45 812	Pillar LF2		1		1		1		KJ00F066G11		
102	E27 J52 812	Pillar LF2	BS		1		1	1		KJ00F066G12		
103	E27 J44 256	Frame assy FB		2		2		2		KS00L328G21		
104	E27 J51 256	Frame assy FB	BS		2		2	2		KS00L328G20		
105	E27 J44 254	Frame assy LR		2		2		2		KS00L332G07		
106	E27 J51 254	Frame assy LR	BS		2		2	2		KS00L332G08		
107	E27 J44 910	Pipe cover		1		1		1		KJ00F069G03		
108	E27 J51 910	Pipe cover	BS		1		1	1		KJ00F069G04		
109	E27 J44 091	Wiring cover		1		1		1		KJ00F070G03		
110	E27 J51 091	Wiring cover	BS		1		1	1		KJ00F070G04		
111	E27 J44 232	Panel F		1		1		1		KS00L334G03		
112	E27 J51 232	Panel F	BS		1		1	1		KS00L334G04		
113	E27 J45 232	Panel B		1		1		1		KS00L337G03		
114	E27 J52 232	Panel B	BS		1		1	1		KS00L337G04		
115	E27 J44 086	Panel L		1		1		1		KS00L340G03		
116	E27 J51 086	Panel L	BS		1		1	1		KS00L340G04		
117	E27 J44 085	Panel R		1		1		1		KS00L341G03		
118	E27 J51 085	Panel R	BS		1		1	1		KS00L341G04		
119	E27 J44 523	Fin guard		1		1		1		KS00R826G05		
120	E27 J51 523	Fin guard	BS		1		1	1		KS00R826G06		
121	E27 981 509	Bell mouth		1	1	1	1	1	1	KB25A620G01		
122	E27 981 521	Fan guard		1	1	1	1	1	1	KB25A623G03		
123	E27 981 810	Plate fanguard		4	4	4	4	4	4	KD02K443G01		
124	E27 E69 290	Fan stand		2		2		2		KS02L499G05		
125	E27 E73 290	Fan stand	BS		2		2	2		KJ00F134G04		
126	E27 J44 301	Outdoor fan motor	DC920 Y	1	1	1	1	1	1	KB61A973B02		
127	E27 J44 501	Propeller fan	700D	1	1	1	1	1	1	KB25Y026G02		
128	E27 622 508	Cap nut	M12	1	1	1	1	1	1	KB12S220H02		
129	E27 622 250	Screw upset	M6 x 10	10	10	10	10	10	10	KB12S261H01	4PCS/UNIT	
130	KJ00F064G01	Attachment leg		4	4	4	4	4	4	KJ00F064G01		
131	E27 633 250	Screw	M5 x 12	20	20	20	20	20	20	KB12S217H01	26PCS/UNIT	
132	E27 983 250	Screw	M5 x 16	10	10	10	10	10	10	KB12S217H02	24PCS/UNIT	
133	E27 623 250	Screw	M5 x 10 KNURLED	20	20	20	20	20	20	KB12S216H01	190PCS/UNIT	

PUHY-EP200,EP250,EP300YNW-A2.TH
PUHY-EP200,EP250,EP300YNW-A2.TH-BS

EXTERNAL PARTS & BLOWER PARTS (1-2)

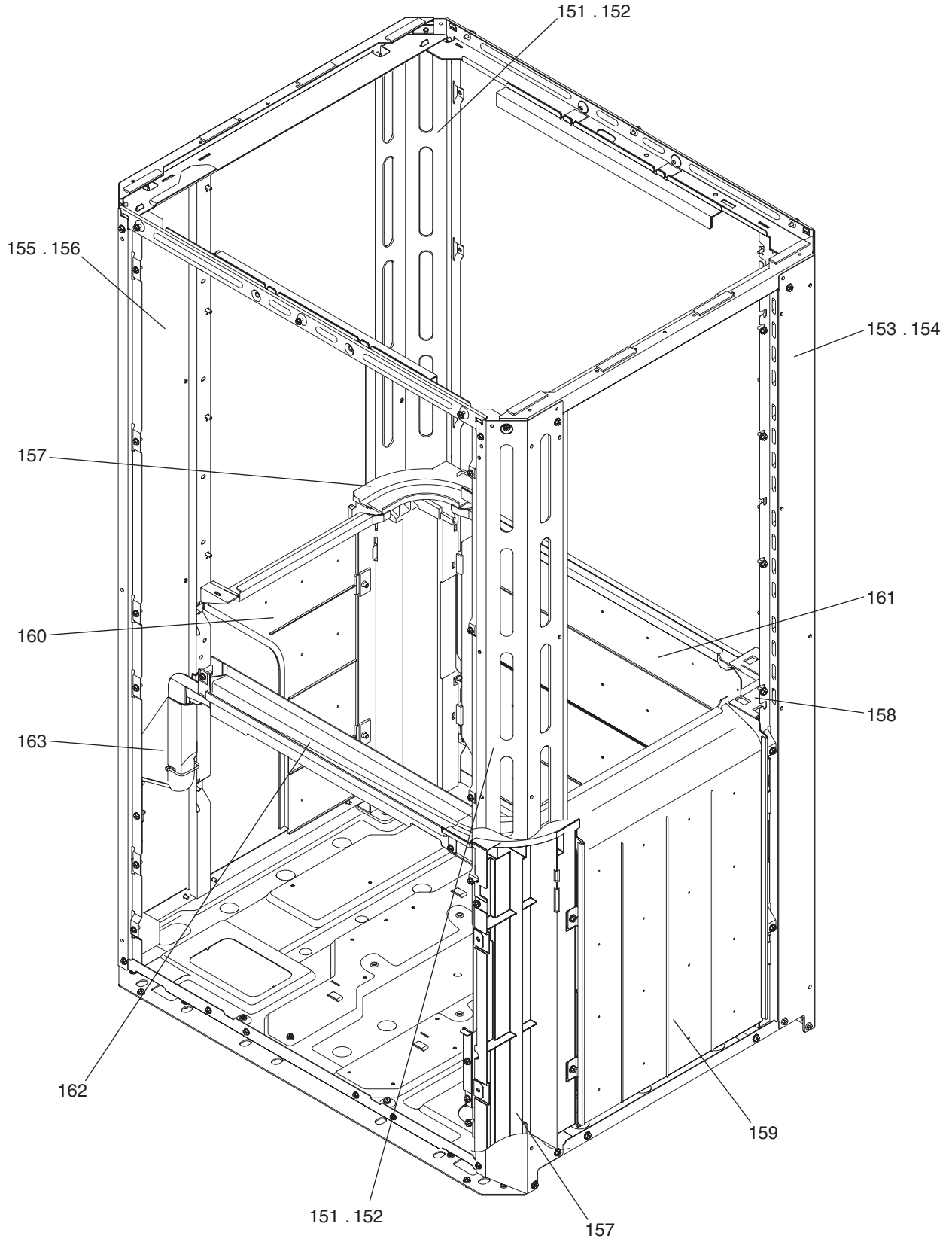

No.	Part No.	Part Name	Spec.							Dwg. No.	Notes for the models	Revision info.
				PUHY-EP200/YNW-A2.TH	PUHY-EP200/YNW-A2.TH-BS	PUHY-EP250/YNW-A2.TH	PUHY-EP250/YNW-A2.TH-BS	PUHY-EP300/YNW-A2.TH	PUHY-EP300/YNW-A2.TH-BS			
151	E27 J44 813	Pillar RF		2		2		2		KS00L323G07		
152	E27 J51 813	Pillar RF	BS		2	2		2		KS00L323G08		
153	E27 R13 814	Pillar RB		1		1		1		KS00L324G11		
154	E27 R23 814	Pillar RB	BS		1	1		1		KS00L324G12		
155	E27 J44 812	Pillar LF1		1		1		1		KS00L325G07		
156	E27 J51 812	Pillar LF1	BS		1	1		1		KS00L325G08		
157	E27 W90 648	Support HEX assy 1		2	2	2	2	2	2	KS00L613G06		
158	E27 J51 648	Support HEX assy 2		1	1	1	1	1	1	KS00L614G04		
159	E27 J44 230	Inner panel assy R		1	1	1	1	1	1	KS00R845G07		
160	E27 J45 230	Inner panel assy L		1	1	1	1	1	1	KS00L615G10		
161	E27 J46 230	Inner panel assy B		1	1	1	1	1	1	KS00R846G11		
162	E27 J44 700	Drain pan assy F		1	1	1	1	1	1	KS00D208G02		
163	E27 J44 540	DEF cover assy		1	1	1	1	1	1	KS00L612G05		

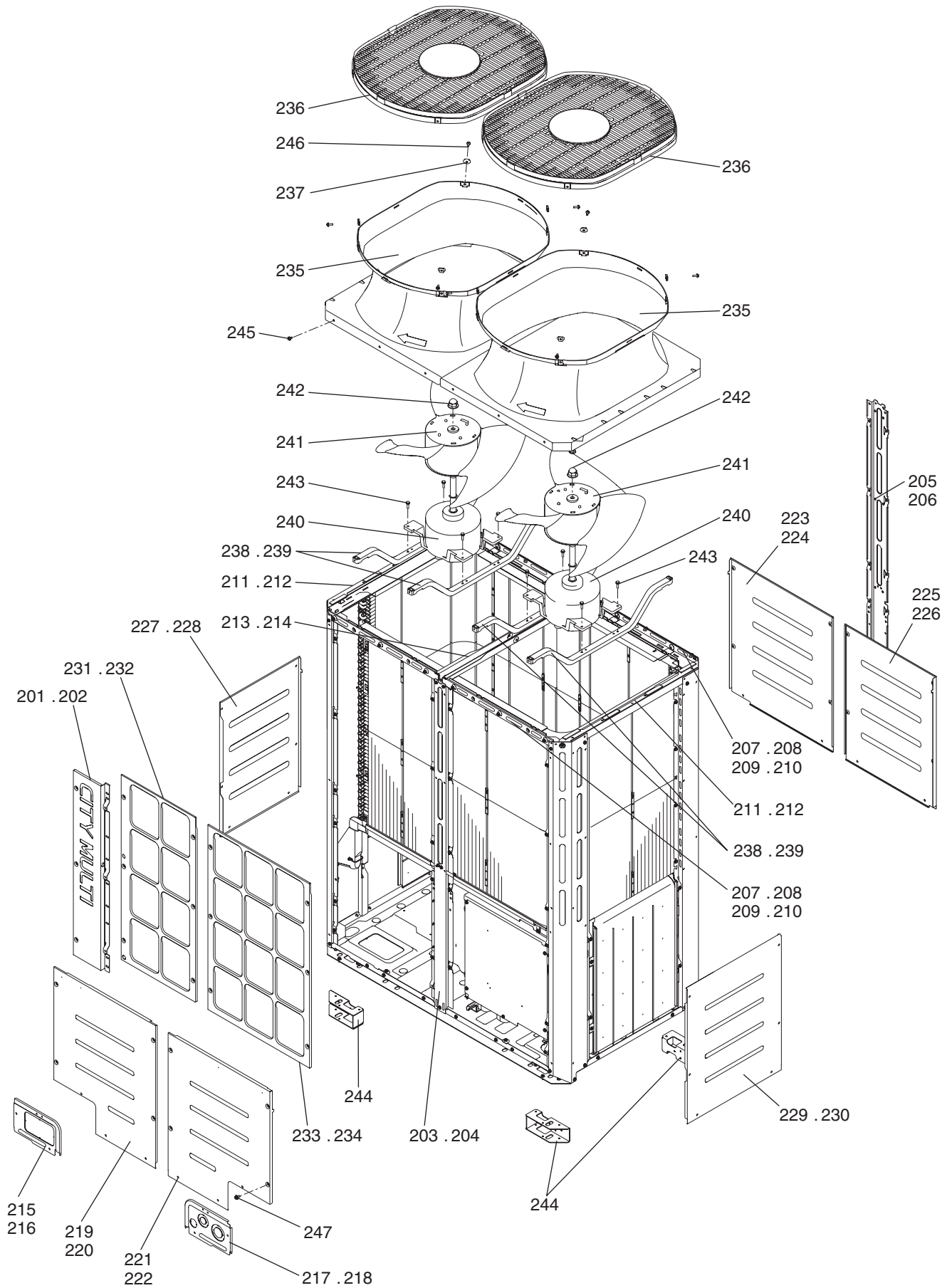

No.	Part No.	Part Name	Spec.							Dwg. No.	Notes for the models	Revision info.
				PUHY-EP350/YNW-A2.TH	PUHY-EP350/YNW-A2.TH-BS	PUHY-EP400/YNW-A2.TH	PUHY-EP400/YNW-A2.TH-BS	PUHY-EP450/YNW-A2.TH	PUHY-EP450/YNW-A2.TH-BS			
201	E27 J45 812	Pillar LF2		1		1		1		KJ00F066G11		
202	E27 J52 812	Pillar LF2	BS		1		1	1		KJ00F066G12		
203	E27 J47 813	Pillar assy C		1		1		1		KS00L326G09		
204	E27 J54 813	Pillar assy C	BS		1		1	1		KS00L326G10		
205	E27 J48 813	Pillar C		1		1		1		KS00L327G09		
206	E27 J55 813	Pillar C	BS		1		1	1		KS00L327G10		
207	E27 J47 256	Frame assy FB		2						KS00L330G21		
208	E27 J54 256	Frame assy FB	BS		2					KS00L330G20		
209	E27 J49 256	Frame assy FB 3L				2		2		KL00C026G19		
210	E27 J56 256	Frame assy FB 3L	BS				2	2		KL00C026G18		
211	E27 J44 254	Frame assy LR		2		2		2		KS00L332G07		
212	E27 J51 254	Frame assy LR	BS		2		2	2		KS00L332G08		
213	E27 R14 255	Frame assy C		1		1		1		KJ00F067G13		
214	E27 R24 255	Frame assy C	BS		1		1	1		KJ00F067G14		
215	E27 J44 910	Pipe cover		1		1		1		KJ00F069G03		
216	E27 J51 910	Pipe cover	BS		1		1	1		KJ00F069G04		
217	E27 J44 091	Wiring cover		1		1		1		KJ00F070G03		
218	E27 J51 091	Wiring cover	BS		1		1	1		KJ00F070G04		
219	E27 J47 232	Panel FL		1		1		1		KS00L335G03		
220	E27 J54 232	Panel FL	BS		1		1	1		KS00L335G04		
221	E27 J48 232	Panel FR		1		1		1		KS00L336G03		
222	E27 J55 232	Panel FR	BS		1		1	1		KS00L336G04		
223	E27 J61 232	Panel BL		1		1		1		KS00L338G03		
224	E27 J68 232	Panel BL	BS		1		1	1		KS00L338G04		
225	E27 J62 232	Panel BR		1		1		1		KS00L339G03		
226	E27 J69 232	Panel BR	BS		1		1	1		KS00L339G04		
227	E27 J44 086	Panel L		1		1		1		KS00L340G03		
228	E27 J51 086	Panel L	BS		1		1	1		KS00L340G04		
229	E27 J44 085	Panel R		1		1		1		KS00L341G03		
230	E27 J51 085	Panel R	BS		1		1	1		KS00L341G04		
231	E27 J47 523	Fin guard FL		1		1		1		KS00R827G05		
232	E27 J54 523	Fin guard FL	BS		1		1	1		KS00R827G06		
233	E27 J48 523	Fin guard FR		1		1		1		KS00R828G03		
234	E27 J55 523	Fin guard FR	BS		1		1	1		KS00R828G04		
235	E27 J47 509	Bell mouth		2	2	2	2	2	2	KB25Y031G02		
236	E27 J47 521	Fan guard		2	2	2	2	2	2	KB25Y028G02		
237	E27 981 810	Plate fanguard		8	8	8	8	8	8	KD02K443G01		
238	E27 E69 290	Fan stand		4		4		4		KS02L499G05		
239	E27 E73 290	Fan stand	BS		4		4	4		KJ00F134G04		
240	E27 J47 301	Outdoor fan motor	L-MW-750-F4-1	2	2	2	2	2	2	KR61C382H02		
241	E27 J47 501	Propeller fan	550D	2	2	2	2	2	2	KB25Y027G02		
242	E27 622 508	Cap nut	M12	2	2	2	2	2	2	KB12S220H02		
243	E27 982 250	Screw upset	M6 × 22	10	10	10	10	10	10	KB12S261H02	8PCS/UNIT	
244	KJ00F064G01	Attachment leg		4	4	4	4	4	4	KJ00F064G01		
245	E27 633 250	Screw	M5 × 12	20	20	20	20	20	20	KB12S217H01	33PCS/UNIT	

PUHY-EP350,EP400,EP450YNW-A2.TH
 PUHY-EP350,EP400,EP450YNW-A2.TH-BS

EXTERNAL PARTS & BLOWER PARTS (2-1)

No.	Part No.	Part Name	Spec.	PUHY-EP350YNW-A2.TH	PUHY-EP350YNW-A2.TH-BS	PUHY-EP400YNW-A2.TH	PUHY-EP400YNW-A2.TH-BS	PUHY-EP450YNW-A2.TH	PUHY-EP450YNW-A2.TH-BS	Dwg. No.	Notes for the models	Revision info.
246	E27 983 250	Screw	M5 × 16	10	10	10	10	10	10	KB12S217H02	29PCS/UNIT	
247	E27 623 250	Screw	M5 × 10 KNURLED	20	20	20	20	20	20	KB12S216H01	208PCS/UNIT	

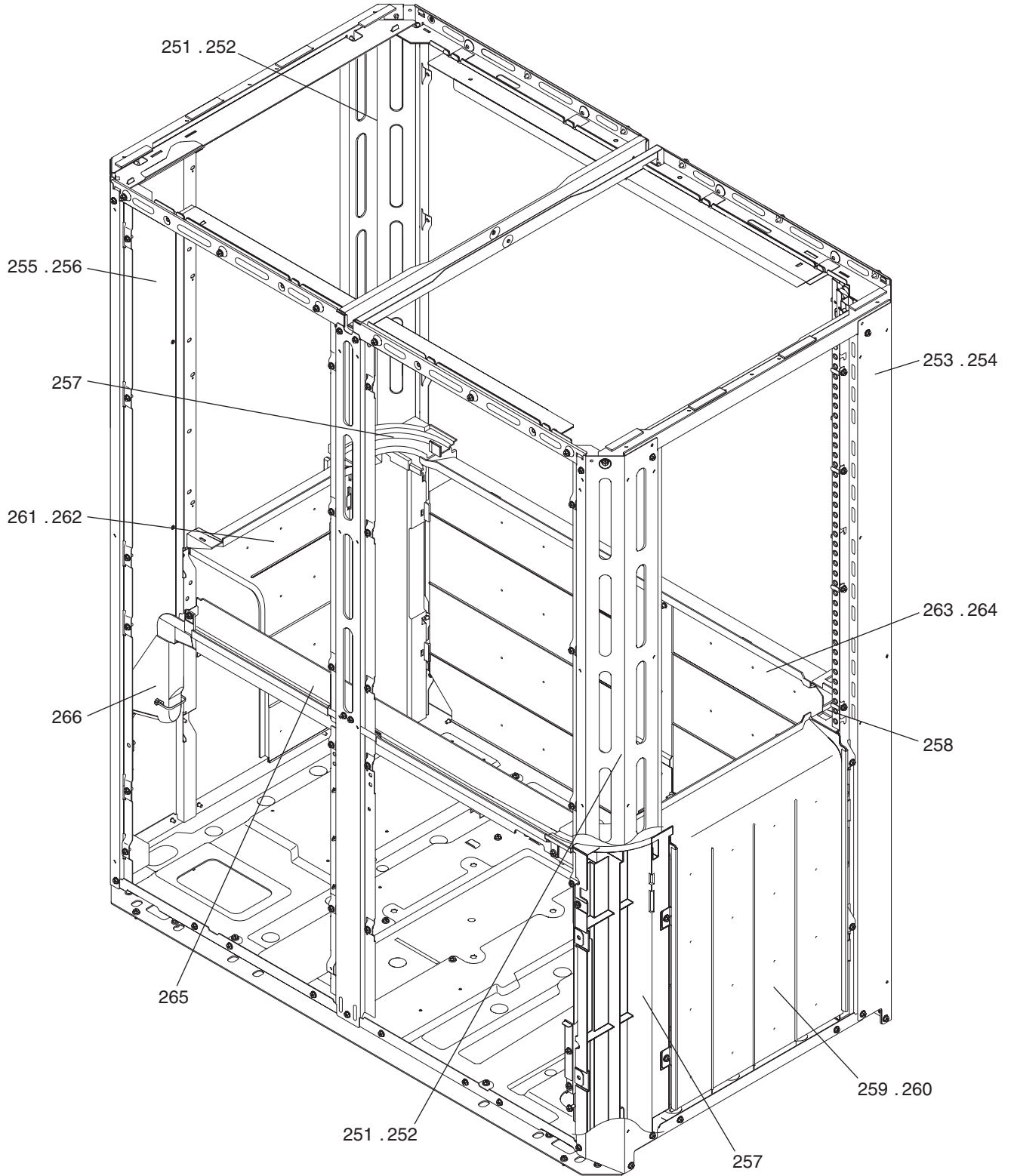

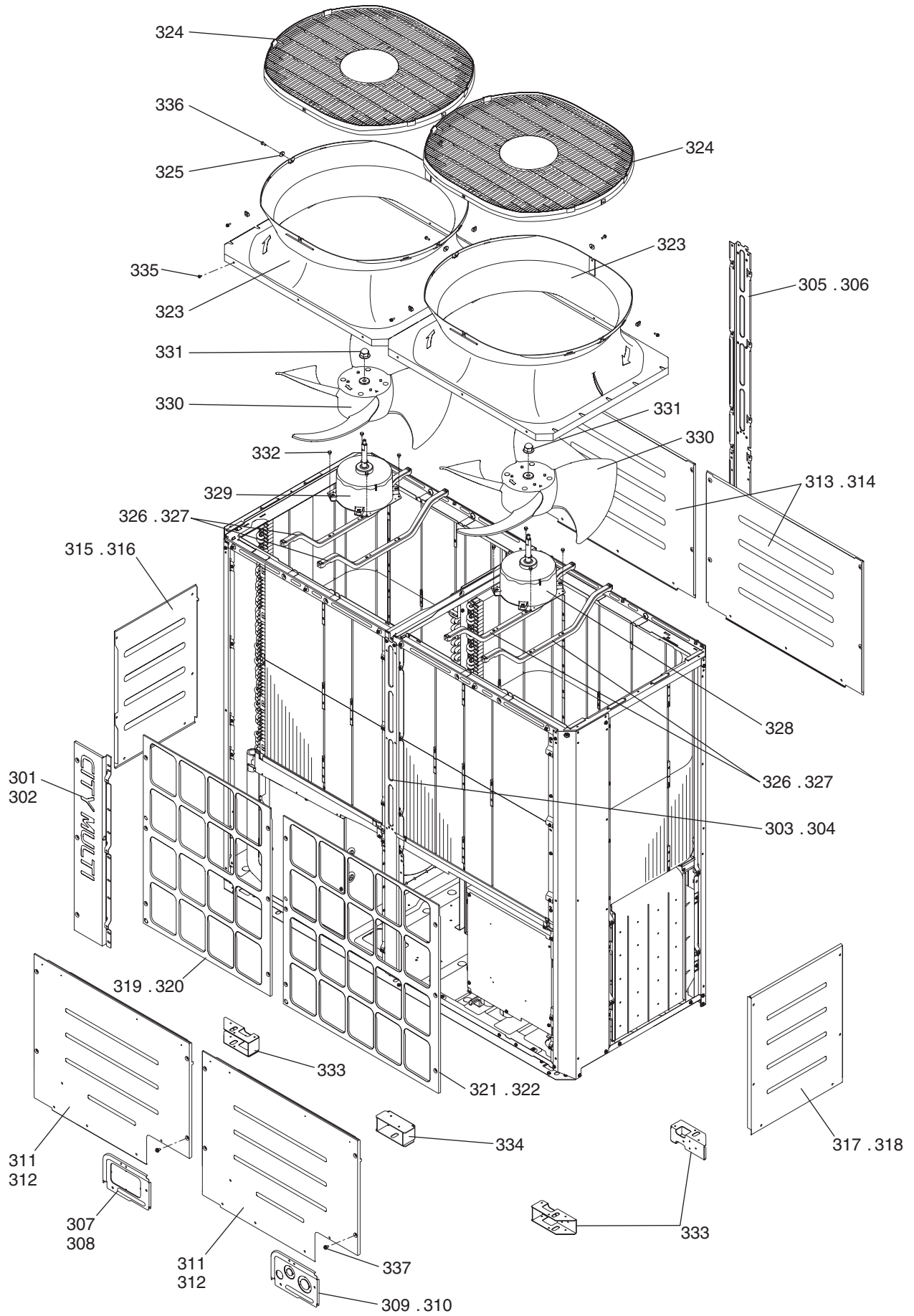

No.	Part No.	Part Name	Spec.	PUHY-EP500YNW-A2.TH		PUHY-EP500YNW-A2.TH-BS		Dwg. No.	Notes for the models	Revision info.
301	E27 J45 812	Pillar LF2		1				KJ00F066G11		
302	E27 J52 812	Pillar LF2	BS	1				KJ00F066G12		
303	E27 J47 813	Pillar assy C		1				KS00L326G09		
304	E27 J54 813	Pillar assy C	BS	1				KS00L326G10		
305	E27 J48 813	Pillar C		1				KS00L327G09		
306	E27 J55 813	Pillar C	BS	1				KS00L327G10		
307	E27 J50 910	Pipe cover		1				KJ00F431G01		
308	E27 J57 910	Pipe cover	BS	1				KJ00F431G02		
309	E27 J44 091	Wiring cover		1				KJ00F070G03		
310	E27 J51 091	Wiring cover	BS	1				KJ00F070G04		
311	E27 J50 232	Panel F		2				KS00R550G03		
312	E27 J57 232	Panel F	BS	2				KS00R550G04		
313	E27 J64 232	Panel B		2				KS00R551G01		
314	E27 J71 232	Panel B	BS	2				KS00R551G02		
315	E27 J44 086	Panel L		1				KS00L340G03		
316	E27 J51 086	Panel L	BS	1				KS00L340G04		
317	E27 J50 085	Panel R		1				KS00R552G03		
318	E27 J57 085	Panel R	BS	1				KS00R552G04		
319	E27 J44 523	Fin guard		1				KS00R826G05		
320	E27 J51 523	Fin guard	BS	1				KS00R826G06		
321	E27 J50 523	Fin guard		1				KS00R843G01		
322	E27 J57 523	Fin guard	BS	1				KS00R843G02		
323	E27 988 509	Bell mouth		2	2			KB25A621G01		
324	E27 981 521	Fan guard		2	2			KB25A623G03		
325	E27 981 810	Plate fanguard		8	8			KD02K443G01		
326	E27 E69 290	Fan stand		4				KS02L499G05		
327	E27 E73 290	Fan stand	BS	4				KJ00F134G04		
328	E27 J44 301	Outdoor fan motor	DC920 Y (RIGHT)	1	1			KB61A973B02		
329	E27 J50 301	Outdoor fan motor	DC920 Y (LEFT)	1	1			KB61A973B03		
330	E27 J44 501	Propeller fan	700D	2	2			KB25Y026G02		
331	E27 622 508	Cap nut	M12	2	2			KB12S220H02		
332	E27 622 250	Screw upset	M6 × 10	10	10			KB12S261H01	8PCS/UNIT	
333	KJ00F064G01	Attachment leg		4	4			KJ00F064G01		
334	KD00P364G02	Attachment leg		2	2			KD00P364G02		
335	E27 633 250	Screw	M5 × 12	20	20			KB12S217H01	47PCS/UNIT	
336	E27 983 250	Screw	M5 × 16	10	10			KB12S217H02	32PCS/UNIT	
337	E27 623 250	Screw	M5 × 10 KNURLED	20	20			KB12S216H01	230PCS/UNIT	

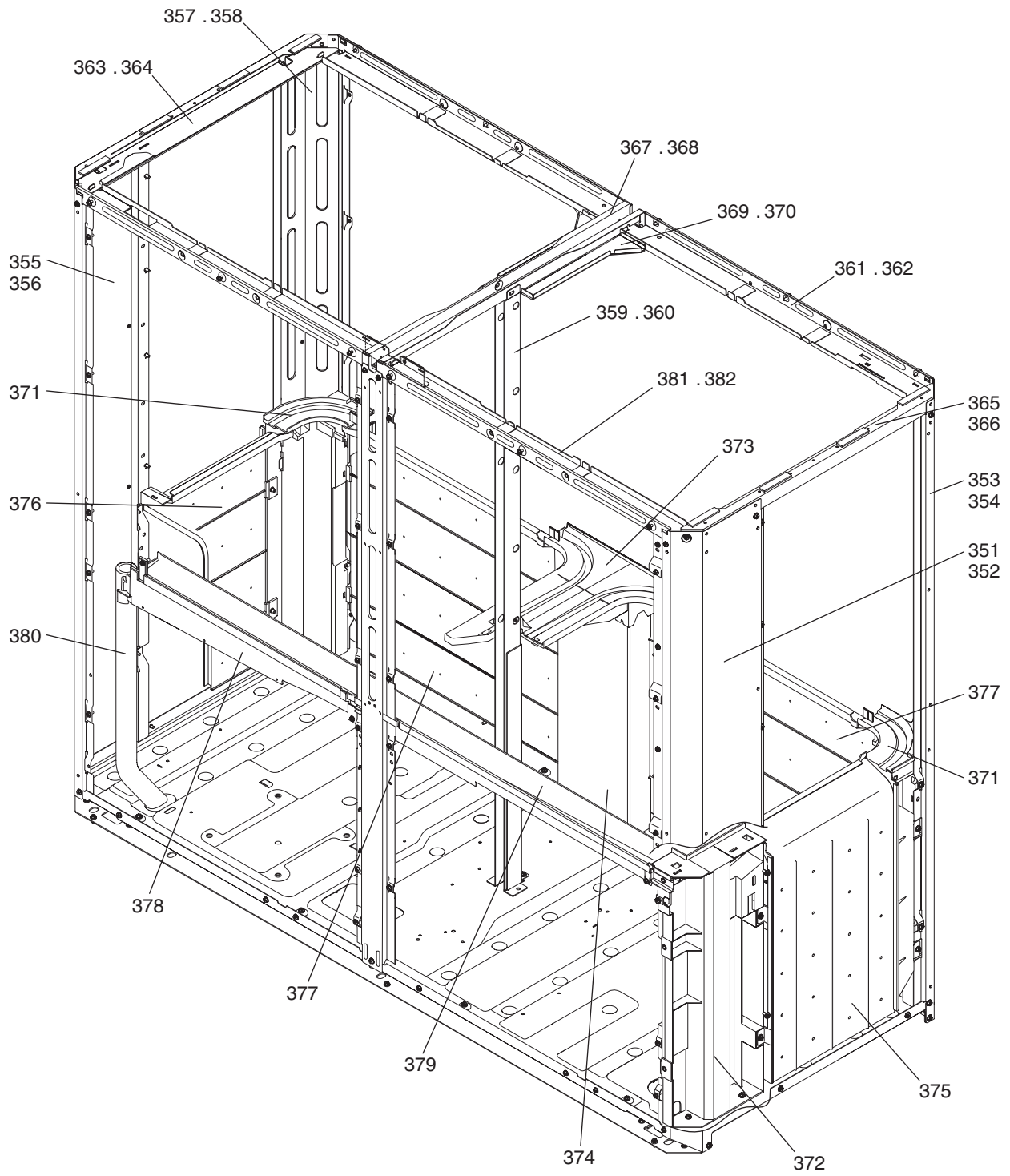

No.	Part No.	Part Name	Spec.	PUHY-EP500YNW-A2.TH	PUHY-EP500YNW-A2.TH-BS					Dwg. No.	Notes for the models	Revision info.
351	E27 J50 813	Pillar RF		1						KS00R542G05		
352	E27 J57 813	Pillar RF	BS	1						KS00R542G06		
353	E27 J50 814	Pillar RB		1						KS00R543G03		
354	E27 J57 814	Pillar RB	BS	1						KS00R543G04		
355	E27 J44 812	Pillar LF1		1						KS00L325G07		
356	E27 J51 812	Pillar LF1	BS	1						KS00L325G08		
357	E27 J44 813	Pillar RF		1						KS00L323G07		
358	E27 J51 813	Pillar RF	BS	1						KS00L323G08		
359	E27 J64 812	Pillar assy M		1						KL00G138G01		
360	E27 J71 812	Pillar assy M	BS	1						KS00R664G06		
361	E27 J50 256	Frame assy FB		1						KS00R544G11		
362	E27 J57 256	Frame assy FB	BS	1						KS00R544G12		
363	E27 J44 254	Frame assy LR		1						KS00L332G07		
364	E27 J51 254	Frame assy LR	BS	1						KS00L332G08		
365	E27 J64 254	Frame assy R		1						KS00R546G03		
366	E27 J71 254	Frame assy R	BS	1						KS00R546G04		
367	E27 R14 255	Frame assy C		1						KJ00F067G13		
368	E27 R24 255	Frame assy C	BS	1						KJ00F067G14		
369	E27 J50 810	Plate top assy		1						KS00R548G07		
370	E27 J57 810	Plate top assy	BS	1						KS00R548G08		
371	E27 W90 648	Support HEX assy 1		2	2					KS00L613G06		
372	E27 J50 648	Support HEX assy 2		1	1					KS00R553G02		
373	E27 J57 648	Support HEX assy MBT		1	1					KB25Y146G03		
374	E27 J64 648	Support HEX assy MBB		1	1					KL00C299G03		
375	E27 J50 230	Inner panel assy R		1	1					KS00T452G09		
376	E27 J45 230	Inner panel assy L		1	1					KS00L615G10		
377	E27 J57 230	Inner panel assy B		2	2					KS00T453G09		
378	E27 J50 700	Drain pan front L		1	1					KB25Y090G03		
379	E27 J57 700	Drain pan assy FR		1	1					KS00R555G06		
380	E27 J50 540	DEF cover		1	1					KL33C263G02		
381	E27 E72 256	Frame assy F		1						KL00C375G07		
382	E27 E84 256	Frame assy F	BS	1						KL00C375G08		

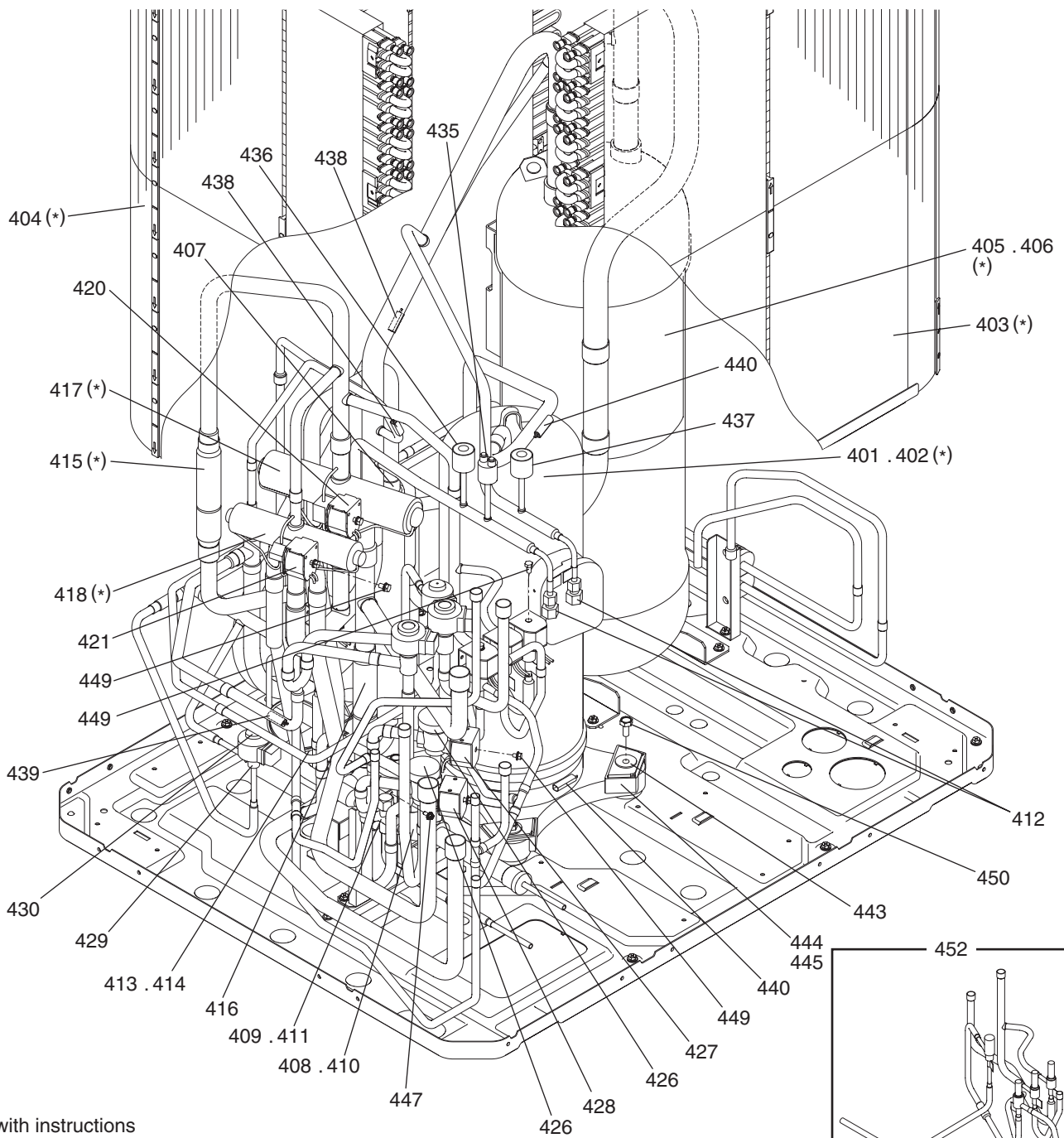

* with instructions

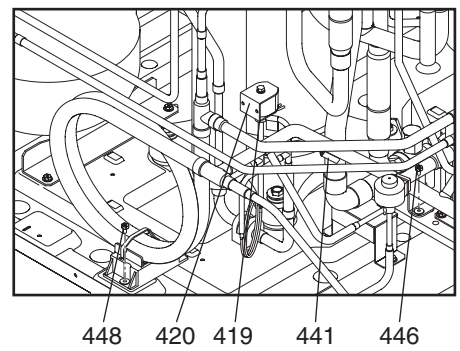
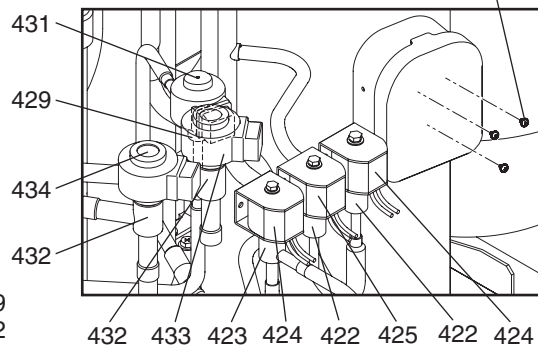
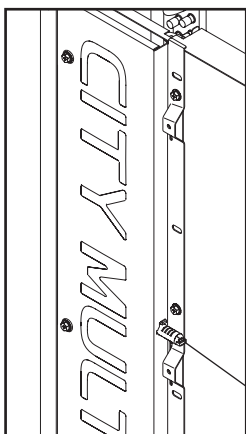

No.	Part No.	Part Name	Spec.							Dwg. No.	Notes for the models	Revision info.
				PUHY-EP200/YNW-A2.TH	PUHY-EP200/YNW-A2.TH-BS	PUHY-EP250/YNW-A2.TH	PUHY-EP250/YNW-A2.TH-BS	PUHY-EP300/YNW-A2.TH	PUHY-EP300/YNW-A2.TH-BS			
401	E27 Y05 900	Compressor SP kit	HNS51FA-YET	1	1	1	1			KJ00K987GA8	*	
402	E27 R20 900	Compressor SP kit	HNS68FA-YET					1	1	KJ00K987G96	*	
403	E27 R33 630	Outdoor heat exchanger	2L F	1	1	1	1	1	1	KJ00H699G03	*	
404	E27 R39 630	Outdoor heat exchanger	2L R	1	1	1	1	1	1	KJ00H700G03	*	
405	E27 W90 932	Accumulator		1		1		1		KJ00K987GA2	*	
406	E27 W97 932	Accumulator	BS		1		1		1	KJ00K987GA3	*	
407	E27 R13 299	Oil separator		1	1	1	1	1	1	KL00L033G02		
408	E27 J44 661	Ball valve	SBV07-005	1	1	1	1	1	1	KR50C373H01	<BV1>	
409	E27 J44 662	Valve	FSV-JA3GME-29	1	1	1	1	1	1	KR50C375H01	<BV2>	
410	E27 624 933	Strainer	25.4D	1	1	1	1	1	1	KD53C139G01	<ST1>	
411	E27 622 933	Strainer	19.05D	1	1	1	1	1	1	KB53S159G01	<ST2>	
412	E27 J44 643	Check joint	R410A	2	2	2	2	2	2	KR50C388H01	<CJ1,CJ2>	
413	E27 622 936	Capillary tube		1	1	1	1			KB49S267G01	<CP1>	
414	E27 A61 936	Capillary tube						1	1	KD49M523G01	<CP1>	
415	E27 R13 642	Check valve 1 SP kit		1	1	1	1	1	1	KJ00K987G85	<CV1>*	
416	E27 J50 642	Check valve	YCV15-014	1	1	1	1	1	1	KR50D176H01	<CV3>	
417	E27 R13 961	Four way valve A SP kit		1	1	1	1	1	1	KJ00K987G86	<21S4a>*	
418	E27 R23 961	Four way valve B SP kit		1	1	1	1	1	1	KJ00K987G87	<21S4b>*	
419	E27 981 492	Solenoid valve	FDF2A77	1	1	1	1	1	1	KR50D126H01	<SV1a>	
420	E27 J44 490	Solenoid valve coil		1	1	1	1	1	1	KS00L538G04	<21S4a,SV1a>	
421	E27 J45 490	Solenoid valve coil		1	1	1	1	1	1	KJ00F150G03	<21S4b>	
422	E27 J44 492	Solenoid valve	FDF4A10	2	2	2	2	2	2	KR50C371H01	<SV2,SV10>	
423	E27 J45 492	Solenoid valve	FDF6A58	1	1	1	1	1	1	KR50C440H01	<SV9>	
424	E27 J46 490	Solenoid valve coil		1	1	1	1	1	1	KS00L539G04	<SV2,SV9>	
425	E27 J47 490	Solenoid valve coil		1	1	1	1	1	1	KJ00F151G03	<SV10>	
426	E27 R34 492	Solenoid valve	FDF11A27	2	2	2	2	2	2	KR50C587H01	<SV14, SV15>	
427	E27 Y05 490	Solenoid valve coil		1	1	1	1	1	1	KJ00F152G04	<SV14>	
428	E27 Y06 490	Solenoid valve coil		1	1	1	1	1	1	KJ00F153G04	<SV15>	
429	E27 A59 640	Linear expansion valve	CAM-B35YGM-DTH-2T	2	2	2	2	2	2	KR50C700H01	<LEV1,LEV9>	
430	E27 J44 493	Solenoid valve coil	CAM-MD12MD-125	1	1	1	1	1	1	KJ00H713G01	<LEV1>	
431	E27 J45 493	Solenoid valve coil	CAM-MD12MD-126	1	1	1	1	1	1	KJ00H717G01	<LEV9>	
432	E27 624 640	Linear expansion valve	PAM-BBOYGM-D-2	2	2	2	2	2	2	KR50C486H01	<LEV2a,LEV2b>	
433	E27 J51 493	Solenoid valve coil	PAM-MD12MD-17	1	1	1	1	1	1	KJ00H714G01	<LEV2a>	
434	E27 J52 493	Solenoid valve coil	PAM-MD12MD-18	1	1	1	1	1	1	KJ00H715G01	<LEV2b>	
435	E27 J44 646	Pressure switch		1	1	1	1	1	1	KD00K089G06	<63H1>	
436	E27 J46 646	Pressure sensor	NSK-BH042D-501	1	1	1	1	1	1	KJ00H708G07	<63HS1>	
437	E27 J44 647	Pressure sensor	NSK-BH017D-505	1	1	1	1	1	1	KJ00H708G08	<63LS1>	
438	E27 J44 307	Thermistor	PXM-41E-M105-01Y	1	1	1	1	1	1	KS00L540G02	<TH2,TH5>	
439	E27 J45 307	Thermistor	PXM-41E-M105-01Y	1	1	1	1	1	1	KS00L541G03	<TH3,TH7>	
440	E27 W90 307	Thermistor	PX2M-56D-M2,PXM-41E-M105-01Y	1	1	1	1	1	1	KS00L542G05	<TH4,TH15>	
441	E27 J51 307	Thermistor	PXM-41E-M105-01Y	1	1	1	1	1	1	KJ00F154G02	<TH6>	
442	E27 622 241	Sensor holder		1	1	1	1	1	1	KB25J374G01	<TH7>	
443	E27 622 506	Comp.rubber mount set	4 Rubbers/SET	4	4	4	4	4	4	KB31S115H01		
444	E27 R13 534	Attachment (HH)		2		2		2		KJ00F713G01		
445	E27 R23 534	Attachment (HH)	BS		2		2		2	KJ00F713G02		

PUHY-EP200,EP250,EP300YNW-A2.TH
 PUHY-EP200,EP250,EP300YNW-A2.TH-BS

FUNCTIONAL PARTS (1)

No.	Part No.	Part Name	Spec.								Dwg. No.	Notes for the models	Revision info.
446	E27 623 250	Screw	M5 × 10 KNURLED	20	20	20	20	20	20	20	KB12S216H01	190PCS/UNIT	
447	E27 630 250	Screw	M5 × 14 KNURLED	10	10	10	10	10	10	10	KB12S216H02	10PCS/UNIT	
448	E27 633 250	Screw	M5 × 12	20	20	20	20	20	20	20	KB12S217H01	26PCS/UNIT	
449	E27 984 250	Screw upset	M5 × 9	10	10	10	10	10	10	10	KD12D936H02	8PCS/UNIT	
450	E27 J47 508	Bolt	M6	10	10	10	10	10	10	10	KJ12F711H05	4PCS/UNIT	
451	E27 632 250	Screw PMP BS	M5 × 10 BRASS	10	10	10	10	10	10	10	KB12S219H01	3PCS/UNIT	
452	E27 R13 963	Pipe assy (SV)		1	1	1	1	1	1	1	KD00J400G02	<SV2,SV9,SV10,LEV9>	

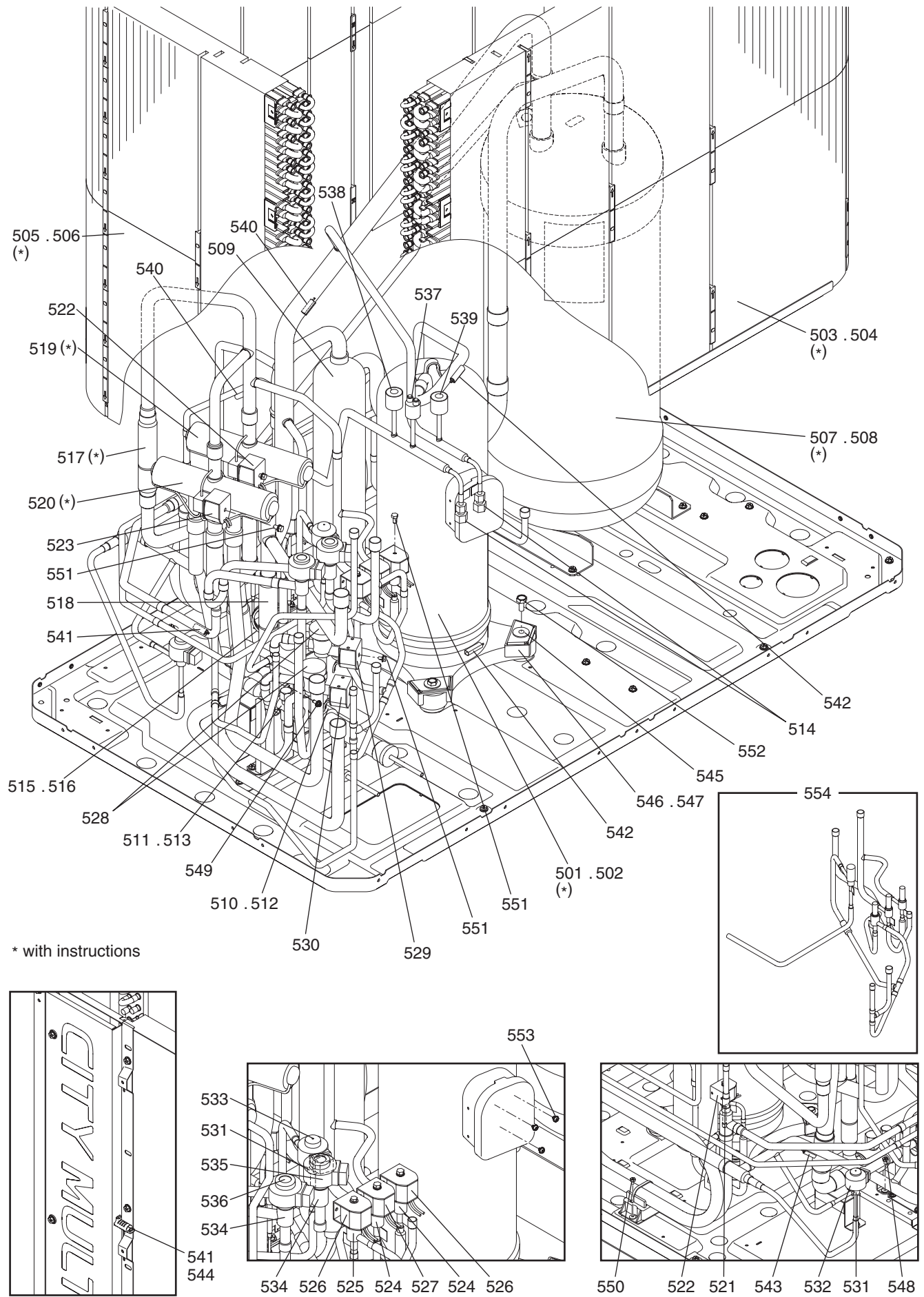

No.	Part No.	Part Name	Spec.							Dwg. No.	Notes for the models	Revision info.
				PUHY-EP350/YNW-A2.TH	PUHY-EP350/YNW-A2.TH-BS	PUHY-EP400/YNW-A2.TH	PUHY-EP400/YNW-A2.TH-BS	PUHY-EP450/YNW-A2.TH	PUHY-EP450/YNW-A2.TH-BS			
501	E27 R20 900	Compressor SP kit	HNS68FA-YET	1	1					KJ00K987G96	*	
502	E27 W94 900	Compressor SP kit	HNB84FE-YE-C			1	1	1	1	KJ00K987GA9	*	
503	E27 R34 630	Outdoor heat exchanger	2L F	1	1					KJ00H701G03	*	
504	E27 R36 630	Outdoor heat exchanger	3L F			1	1	1	1	KJ00H702G05	*	
505	E27 R35 630	Outdoor heat exchanger	2L R	1	1					KJ00H703G03	*	
506	E27 R42 630	Outdoor heat exchanger	3L R			1	1	1	1	KJ00H704G03	*	
507	E27 W93 932	Accumulator		1		1		1		KJ00K987GA4	*	
508	E27 Y01 932	Accumulator	BS		1		1		1	KJ00K987GA5	*	
509	E27 J44 299	Oil separator		1	1	1	1	1	1	KS00G735G02		
510	E27 J47 661	Ball valve	SBV10-005	1	1	1	1	1	1	KR50C374H01	<BV1>	
511	E27 J47 662	Valve	FSV-JA4GME-6	1	1	1	1	1	1	KR50C376H01	<BV2>	
512	E27 J47 933	Strainer	28.6D	1	1	1	1	1	1	KR48C381H01	<ST1>	
513	E27 622 933	Strainer	19.05D	1	1	1	1	1	1	KB53S159G01	<ST2>	
514	E27 J44 643	Check joint	R410A	2	2	2	2	2	2	KR50C388H01	<CJ1,CJ2>	
515	E27 A61 936	Capillary tube		1	1					KD49M523G01	<CP1>	
516	E27 A63 936	Capillary tube				1	1	1	1	KD49M579G01	<CP1>	
517	E27 R13 642	Check valve 1 SP kit		1	1	1	1	1	1	KJ00K987G85	<CV1>*	
518	E27 J50 642	Check valve	YCV15-014	1	1	1	1	1	1	KR50D176H01	<CV3>	
519	E27 R14 961	Four way valve A SP kit		1	1	1	1	1	1	KJ00K987G88	<21S4a>*	
520	E27 R15 961	Four way valve B SP kit		1	1	1	1	1	1	KJ00K987G89	<21S4b>*	
521	E27 981 492	Solenoid valve	FDF2A77	1	1	1	1	1	1	KR50D126H01	<SV1a>	
522	E27 J48 490	Solenoid valve coil		1	1	1	1	1	1	KS00L586G04	<21S4a,SV1a>	
523	E27 J49 490	Solenoid valve coil		1	1	1	1	1	1	KJ00F204G04	<21S4b>	
524	E27 J44 492	Solenoid valve	FDF4A10	2	2	2	2	2	2	KR50C371H01	<SV2,SV10>	
525	E27 J45 492	Solenoid valve	FDF6A58	1	1	1	1	1	1	KR50C440H01	<SV9>	
526	E27 J71 490	Solenoid valve coil		1	1	1	1	1	1	KS00L587G04	<SV2,SV9>	
527	E27 J72 490	Solenoid valve coil		1	1	1	1	1	1	KJ00F205G03	<SV10>	
528	E27 R34 492	Solenoid valve	FDF11A27	2	2	2	2	2	2	KR50C587H01	<SV14,SV15>	
529	E27 Y08 490	Solenoid valve coil		1	1	1	1	1	1	KJ00F206G04	<SV14>	
530	E27 Y09 490	Solenoid valve coil		1	1	1	1	1	1	KJ00F207G04	<SV15>	
531	E27 A59 640	Linear expansion valve	CAM-B35YGMDTH-2T	2	2	2	2	2	2	KR50C700H01	<LEV1,LEV9>	
532	E27 J44 493	Solenoid valve coil	CAM-MD12MD-125	1	1	1	1	1	1	KJ00H713G01	<LEV1>	
533	E27 J45 493	Solenoid valve coil	CAM-MD12MD-126	1	1	1	1	1	1	KJ00H717G01	<LEV9>	
534	E27 624 640	Linear expansion valve	PAM-BBOYGMD-2	2	2	2	2	2	2	KR50C486H01	<LEV2a,LEV2b>	
535	E27 J51 493	Solenoid valve coil	PAM-MD12MD-17	1	1	1	1	1	1	KJ00H714G01	<LEV2a>	
536	E27 J52 493	Solenoid valve coil	PAM-MD12MD-18	1	1	1	1	1	1	KJ00H715G01	<LEV2b>	
537	E27 J44 646	Pressure switch		1	1	1	1	1	1	KD00K089G06	<63H1>	
538	E27 J46 646	Pressure sensor	NSK-BH042D-501	1	1	1	1	1	1	KJ00H708G07	<63HS1>	
539	E27 J44 647	Pressure sensor	NSK-BH017D-505	1	1	1	1	1	1	KJ00H708G08	<63LS1>	
540	E27 J47 307	Thermistor	PXM-41E-M105-01Y	1	1	1	1	1	1	KS00L588G02	<TH2,TH5>	
541	E27 J48 307	Thermistor	PXM-41E-M105-01Y	1	1	1	1	1	1	KS00L589G03	<TH3,TH7>	
542	E27 Y08 307	Thermistor	PX2M-56D-M2,PXM-41E-M105-01Y	1	1	1	1	1	1	KS00L590G05	<TH4,TH15>	
543	E27 J71 307	Thermistor	PXM-41E-M105-01Y	1	1	1	1	1	1	KJ00F208G02	<TH6>	
544	E27 622 241	Sensor holder		1	1	1	1	1	1	KB25J374G01	<TH7>	
545	E27 622 506	Comp.rubber mount set	4 Rubbers/SET	4	4	4	4	4	4	KB31S115H01		

No.	Part No.	Part Name	Spec.							Dwg. No.	Notes for the models	Revision info.
				PUHY-EP350/YNW-A2.TH	PUHY-EP350/YNW-A2.TH-BS	PUHY-EP400/YNW-A2.TH	PUHY-EP400/YNW-A2.TH-BS	PUHY-EP450/YNW-A2.TH	PUHY-EP450/YNW-A2.TH-BS			
546	E27 R13 534	Attachment (HH)		2		2		2		KJ00F713G01		
547	E27 R23 534	Attachment (HH)	BS		2	2		2		KJ00F713G02		
548	E27 623 250	Screw	M5 × 10 KNURLED	20	20	20	20	20	20	KB12S216H01	208PCS/UNIT	
549	E27 630 250	Screw	M5 × 14 KNURLED	10	10	10	10	10	10	KB12S216H02	6PCS/UNIT	
550	E27 633 250	Screw	M5 × 12	20	20	20	20	20	20	KB12S217H01	33PCS/UNIT	
551	E27 984 250	Screw upset	M5 × 9	10	10	10	10	10	10	KD12D936H02	8PCS/UNIT	
552	E27 J47 508	Bolt	M6	10	10	10	10	10	10	KJ12F711H05	4PCS/UNIT	
553	E27 632 250	Screw PMP BS	M5 × 10 BRASS	10	10	10	10	10	10	KB12S219H01	3PCS/UNIT	
554	E27 R13 963	Pipe Assy (SV)		1	1	1	1	1	1	KD00J400G02	<SV2,SV9,SV10,LEV9>	

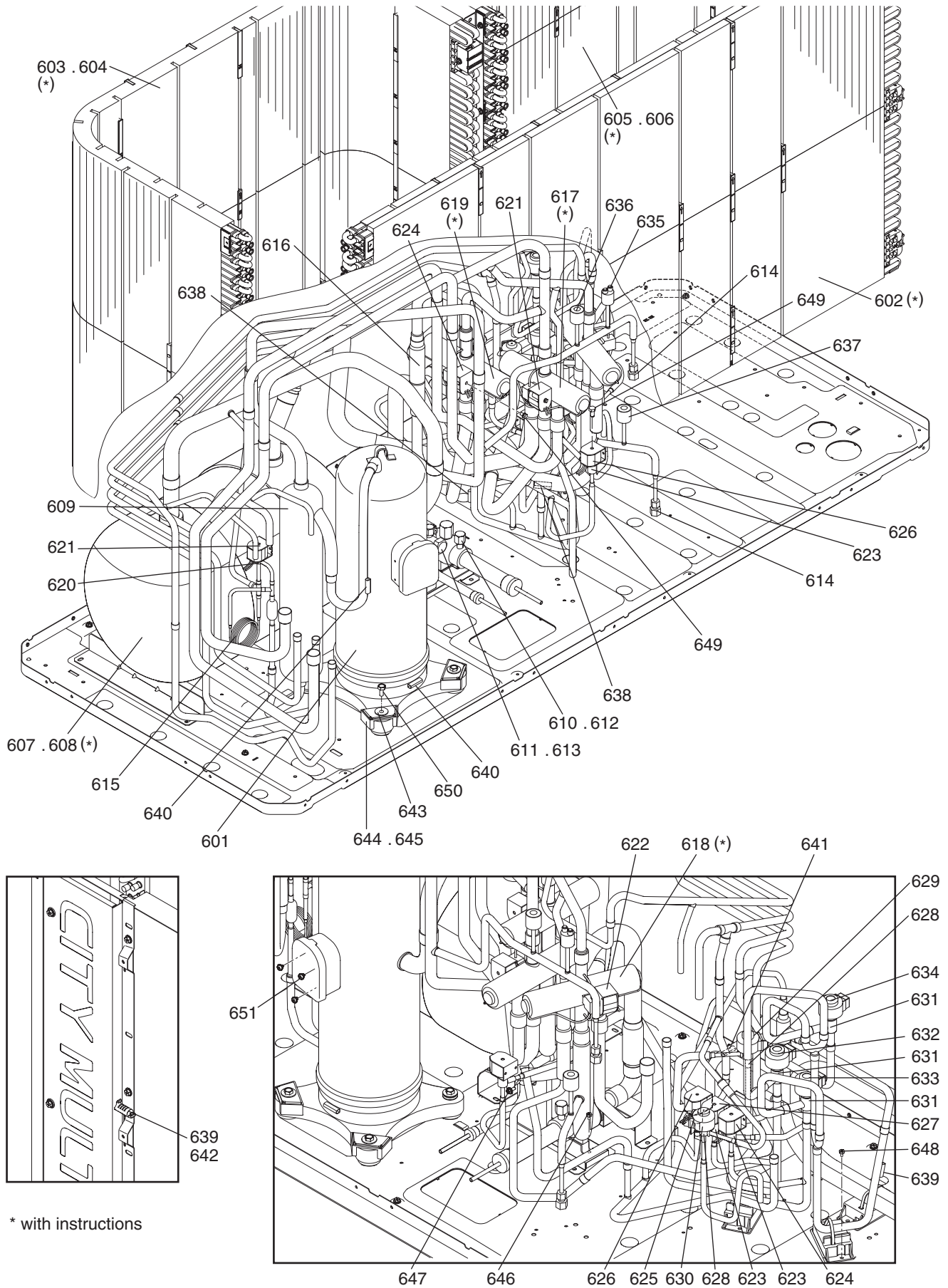

No.	Part No.	Part Name	Spec.	PUHY-EP500YNW-A2.TH	PUHY-EP500YNW-A2.TH-BS					Dwg. No.	Notes for the models	Revision info.
601	E27 W96 900	Compressor	HNB97FB-YET	1	1					KEP10148B06		
602	E27 R37 630	Outdoor heat exchanger	2L F	1	1					KJ00H705G03	*	
603	E27 R38 630	Outdoor heat exchanger	2L L	1						KJ00H706G05	*	
604	E27 R49 630	Outdoor heat exchanger	2L L BS		1					KJ00H706G06	*	
605	E27 R43 630	Outdoor heat exchanger	2L R	1						KJ00H707G05	*	
606	E27 R55 630	Outdoor heat exchanger	2L R BS		1					KJ00H707G06	*	
607	E27 W96 932	Accumulator		1						KJ00K987GA6	*	
608	E27 Y04 932	Accumulator	BS		1					KJ00K987GA7	*	
609	E27 J50 299	Oil separator		1	1					KS00R335G03		
610	E27 J47 661	Ball valve	SBV10-005	1	1					KR50C374H01	<BV1>	
611	E27 J50 662	Valve	FSV-JA5GME-34	1	1					KR50C377H01	<BV2>	
612	E27 J47 933	Strainer	28.6D	1	1					KR48C381H01	<ST1>	
613	E27 622 933	Strainer	19.05D	1	1					KB53S159G01	<ST2>	
614	E27 J50 643	Check joint	R410A	2	2					KR50C379H01	<CJ1,CJ2>	
615	E27 627 936	Capillary tube		1	1					KB49S487G01	<CP1>	
616	E27 J50 642	Check valve	YCV15-014	1	1					KR50D176H01	<CV1>	
617	E27 R17 961	Four way valve A SP kit		1	1					KJ00K987GB5	<21S4a>*	
618	E27 R22 961	Four way valve B SP kit		1	1					KJ00K987GB6	<21S4b>*	
619	E27 R27 961	Four way valve C SP kit		1	1					KJ00K987GB7	<21S4c>*	
620	E27 981 492	Solenoid valve	FD2A77	1	1					KR50D126H01	<SV1a>	
621	E27 W96 490	Solenoid valve coil		1	1					KL00R189G02	<21S4a,SV1a>	
622	E27 Y04 490	Solenoid valve coil		1	1					KJ00K375G02	<21S4b>	
623	E27 J44 492	Solenoid valve	FD4A10	3	3					KR50C371H01	<SV2,SV10,SV11>	
624	E27 Y25 490	Solenoid valve coil		1	1					KL00R201G02	<21S4c,SV11>	
625	E27 J45 492	Solenoid valve	FD6A58	1	1					KR50C440H01	<SV9>	
626	E27 Y11 490	Solenoid valve coil		1	1					KL00R200G02	<SV2,SV9>	
627	E27 Y18 490	Solenoid valve coil		1	1					KJ00K378G02	<SV10>	
628	E27 A59 640	Linear expansion valve	CAM-B35YGMTH-2T	2	2					KR50C700H01	<LEV1,LEV9>	
629	E27 J44 493	Solenoid valve coil	CAM-MD12MD-125	1	1					KJ00H713G01	<LEV1>	
630	E27 J45 493	Solenoid valve coil	CAM-MD12MD-126	1	1					KJ00H717G01	<LEV9>	
631	E27 624 640	Linear expansion valve	PAM-BBOYGM-2	3	3					KR50C486H01	<LEV2a,LEV2b,LEV2c>	
632	E27 J51 493	Solenoid valve coil		1	1					KJ00H714G01	<LEV2a>	
633	E27 J52 493	Solenoid valve coil	PAM-MD12MD-18	1	1					KJ00H715G01	<LEV2b>	
634	E27 J57 493	Solenoid valve coil	PAM-MD12MD-19	1	1					KJ00H716G01	<LEV2c>	
635	E27 J44 646	Pressure switch		1	1					KD00K089G06	<63H1>	
636	E27 J50 646	Pressure sensor	NSK-BH042D-501	1	1					KJ00H708G03	<63HS1>	
637	E27 W96 647	Pressure sensor	NSK-BH017D-505	1	1					KJ00H708G09	<63LS1>	
638	E27 E80 307	Thermistor	PXM-41E-M105-01Y	1	1					KS00R689G02	<TH2,TH5>	
639	E27 J50 307	Thermistor	PXM-41E-M105-01Y	1	1					KS00R690G03	<TH3,TH7>	
640	E27 J57 307	Thermistor	PX2M-56D-M2,PXM-41E-M105-01Y	1	1					KS00R691G03	<TH4,TH15>	
641	E27 J64 307	Thermistor	PXM-41E-M105-01Y	1	1					KJ00F456G02	<TH6>	
642	E27 622 241	Sensor holder		1	1					KB25J374G01	<TH7>	
643	E27 622 506	Comp.rubber mount set	4 Rubbers/SET	4	4					KB31S115H01		
644	E27 R13 534	Attachment (HH)		2						KJ00F713G01		
645	E27 R23 534	Attachment (HH)	BS		2					KJ00F713G02		

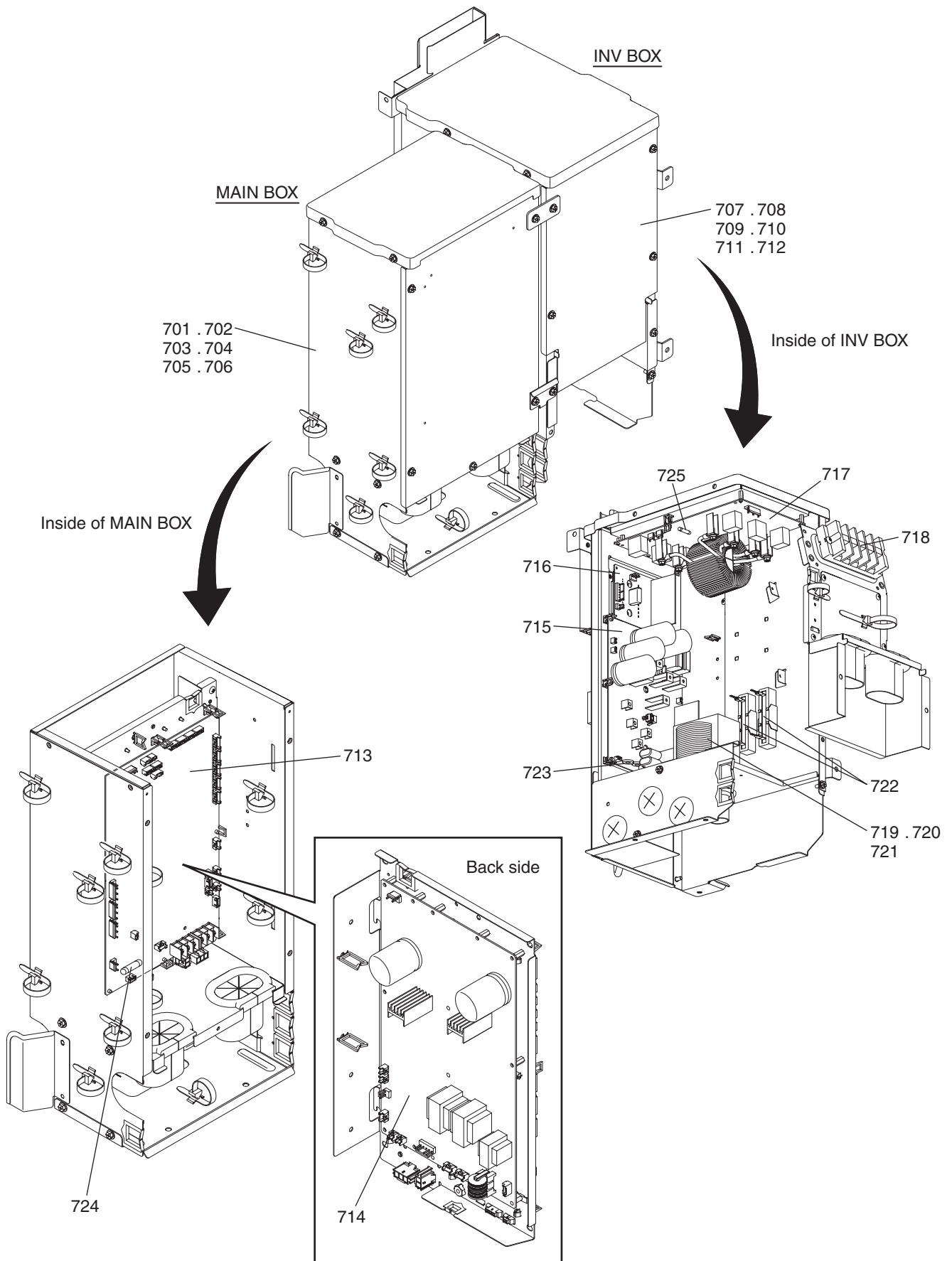

Notice:Consult your service agency when the wiring needs to be replaced.
 (Replacing wiring will take about 2 months.)

PUHY-EP200,EP250,EP300YNW-A2.TH
 PUHY-EP200,EP250,EP300YNW-A2.TH-BS

CONTROL BOX PARTS (1)

No.	Part No.	Part Name	Spec.							Dwg. No.	Notes for the models	Revision info.
				PUHY-EP200/YNW-A2.TH	PUHY-EP200/YNW-A2.TH-BS	PUHY-EP250/YNW-A2.TH	PUHY-EP250/YNW-A2.TH-BS	PUHY-EP300/YNW-A2.TH	PUHY-EP300/YNW-A2.TH-BS			
701	E27 09M 081	Control box	Y-EP200	1						KE00J398BE1	<MAIN BOX>	
702	E27 16M 081	Control box	Y-EP200 BS		1					KE00J398BE2	<MAIN BOX>	
703	E27 10M 081	Control box	Y-EP250			1				KE00J398BE3	<MAIN BOX>	
704	E27 17M 081	Control box	Y-EP250 BS				1			KE00J398BE4	<MAIN BOX>	
705	E27 11M 081	Control box	Y-EP300					1		KE00J398BE5	<MAIN BOX>	
706	E27 18M 081	Control box	Y-EP300 BS						1	KE00J398BE6	<MAIN BOX>	
707	E27 80L 081	Control box	Y-P200,Y-(E)P200	1						KE00J398BE7	<INV BOX>	
708	E27 87L 081	Control box	Y-P200 BS,Y-EP200 BS		1					KE00J398BE8	<INV BOX>	
709	E27 81L 081	Control box	Y-P250,Y-EP250			1				KE00J398BE9	<INV BOX>	
710	E27 88L 081	Control box	Y-P250 BS,Y-EP250 BS				1			KE00J398BF0	<INV BOX>	
711	E27 82L 081	Control box	Y-P300,Y-EP300					1		KE00J398BF1	<INV BOX>	
712	E27 89L 081	Control box	Y-P300 BS,Y-EP300 BS						1	KE00J398BF2	<INV BOX>	
713	E27 R13 450	Control board		1	1	1	1	1	1	KE01H430B01	<MAIN12>	
714	E27 W90 440	PS board		1	1	1	1	1	1	KE01H428B02	<PS02>	
715	E27 W90 451	INV board		1	1	1	1	1	1	KE01F965B03	<INV35Y>	
716	E27 W90 455	Fan board		1	1	1	1	1	1	KE01H520B01	<INV/S19Y>	
717	E27 W90 444	Noise filter		1	1	1	1	1	1	KE01H436B02	<Noise filter>	
718	E27 622 374	Terminal block		1	1	1	1	1	1	KR73C225H01	<TB1>	
719	E27 R18 337	Reactor		1	1					KR65C399H02	<DCL>	
720	E27 W91 337	Reactor				1	1			KR65C400H03	<DCL>	
721	E27 W92 337	Reactor						1	1	KR65C401H03	<DCL>	
722	E27 622 360	Resistor		2	2	2	2	2	2	KR63C218H01	<R1,R5>	
723	E27 J44 364	AC Current sensor		1	1	1	1	1	1	KR66C391H01	<ACCT1,2>	
724	E27 D58 382	Fuse	3.15A AC250V T	1	1	1	1	1	1	YE81D827H02		
725	E27 250 382	Fuse	6.3A AC250V T	1	1	1	1	1	1	YE81G542H22		

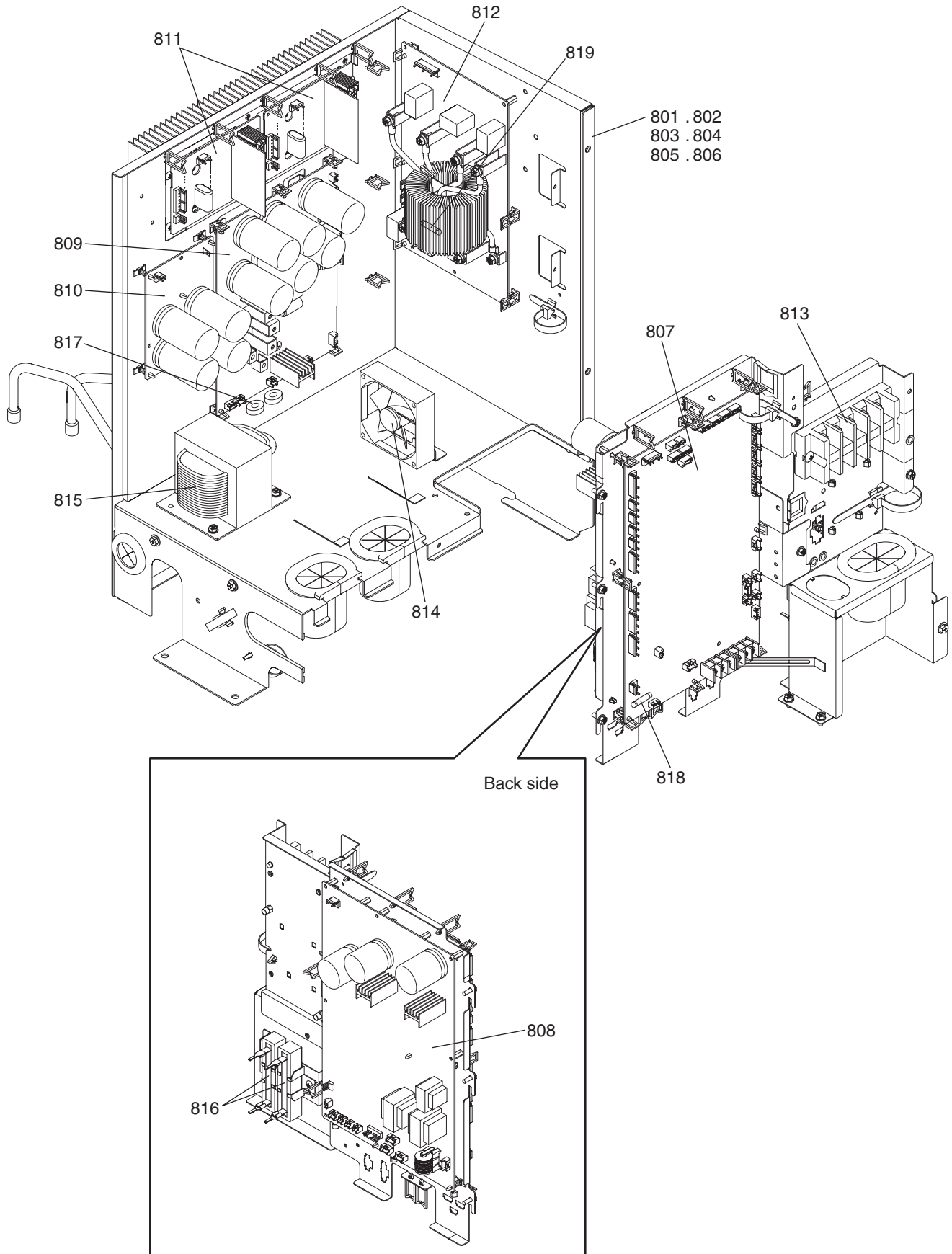

Notice: Consult your service agency when the wiring needs to be replaced.
(Replacing wiring will take about 2 months.)

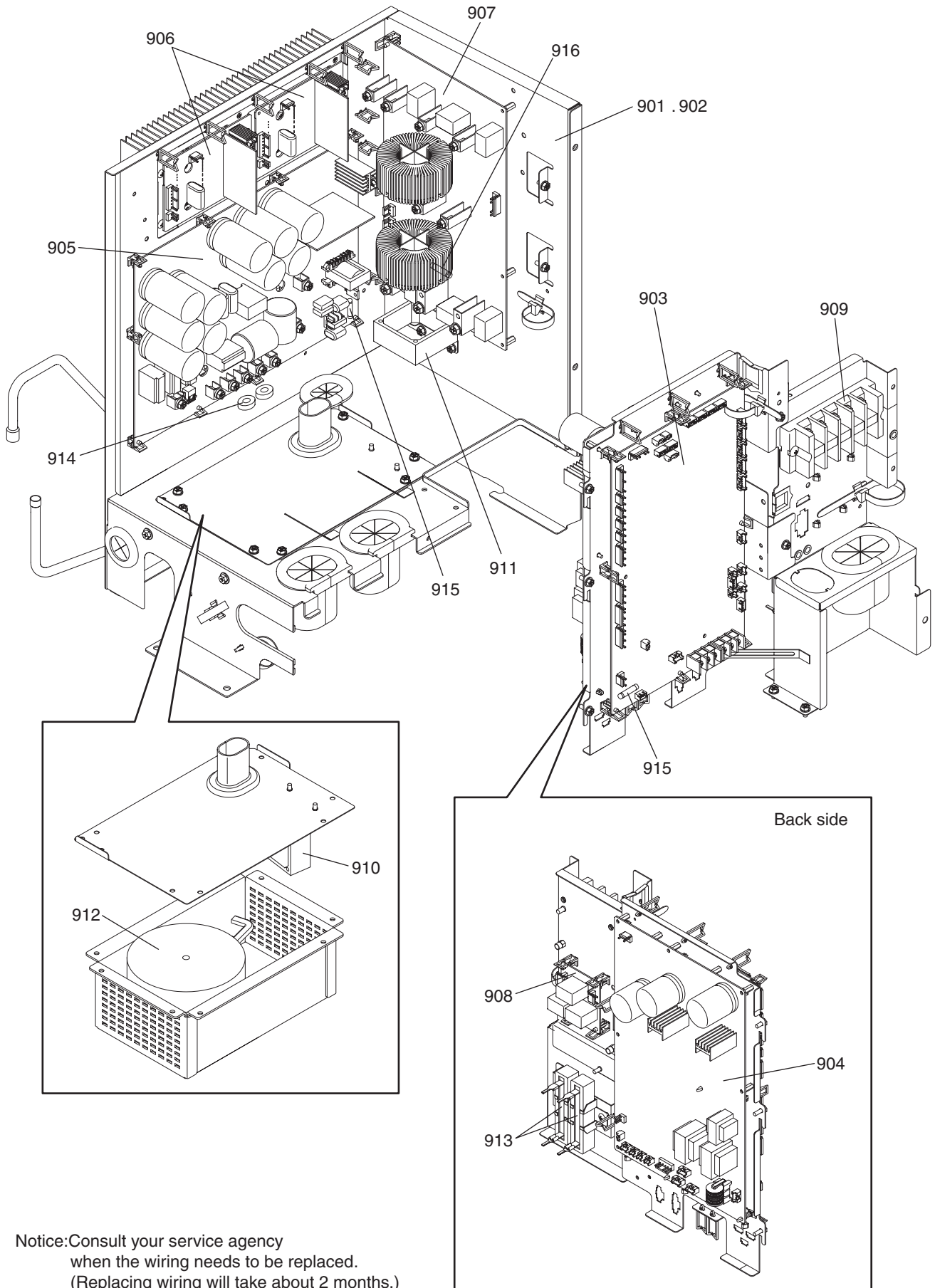

Notice: Consult your service agency
 when the wiring needs to be replaced.
 (Replacing wiring will take about 2 months.)

PUHY-EP500YNW-A2.TH
 PUHY-EP500YNW-A2.TH-BS

CONTROL BOX PARTS (3)

No.	Part No.	Part Name	Spec.	PUHY-EP500YNW-A2.TH	PUHY-EP500YNW-A2.TH-BS							Dwg. No.	Notes for the models	Revision info.
901	E27 15M 081	Control box	Y-EP500	1								KE00J398BK7		
902	E27 22M 081	Control box	Y-EP500 BS		1							KE00J398BK8		
903	E27 R13 450	Control board		1	1							KE01H430B01	<MAIN12>	
904	E27 W93 440	PS board		1	1							KE01H429B03	<PS board>	
905	E27 W96 451	INV board		1	1							KE01F968B03	<INV37YC>	
906	E27 W90 455	Fan board		2	2							KE01H520B01	<INV/S19Y>	
907	E27 W96 444	Noise filter		1	1							KE01H437B02	<Noise filter>	
908	E27 Y04 444	Filter board		1	1							KE01F973B02	<Filter board>	
909	E27 622 374	Terminal block		1	1							KR73C225H01	<TB1>	
910	E27 R37 503	Fan		1	1							KR55C522H01	<FAN>	
911	E27 R38 503	Fan		1	1							KR55C521H01	<FAN>	
912	E27 R55 337	Reactor		1	1							KR65C403H03	<DCL>	
913	E27 622 360	Resistor		2	2							KR63C218H01	<R1,R5>	
914	E27 J44 364	AC Current sensor		1	1							KR66C391H01	<ACCT1,2>	
915	E27 D58 382	Fuse	3.15A AC250V T	2	2							YE81D827H02		
916	E27 250 382	Fuse	6.3A AC250V T	1	1							YE81G542H22		

mitsubishi electric corporation

BWE021560 (20220331)