

PUHY-EP200, 250, 300YNW-A2 (-BS)

Unit: mm

- Note 1. Please refer to the next page for information regarding necessary spacing around the unit and foundation work.
 2. The detachable leg can be removed at site.
 3. At brazing of pipes, wrap the refrigerant service valve with wet cloth and keep the temperature of refrigerant service valve under 120°C.

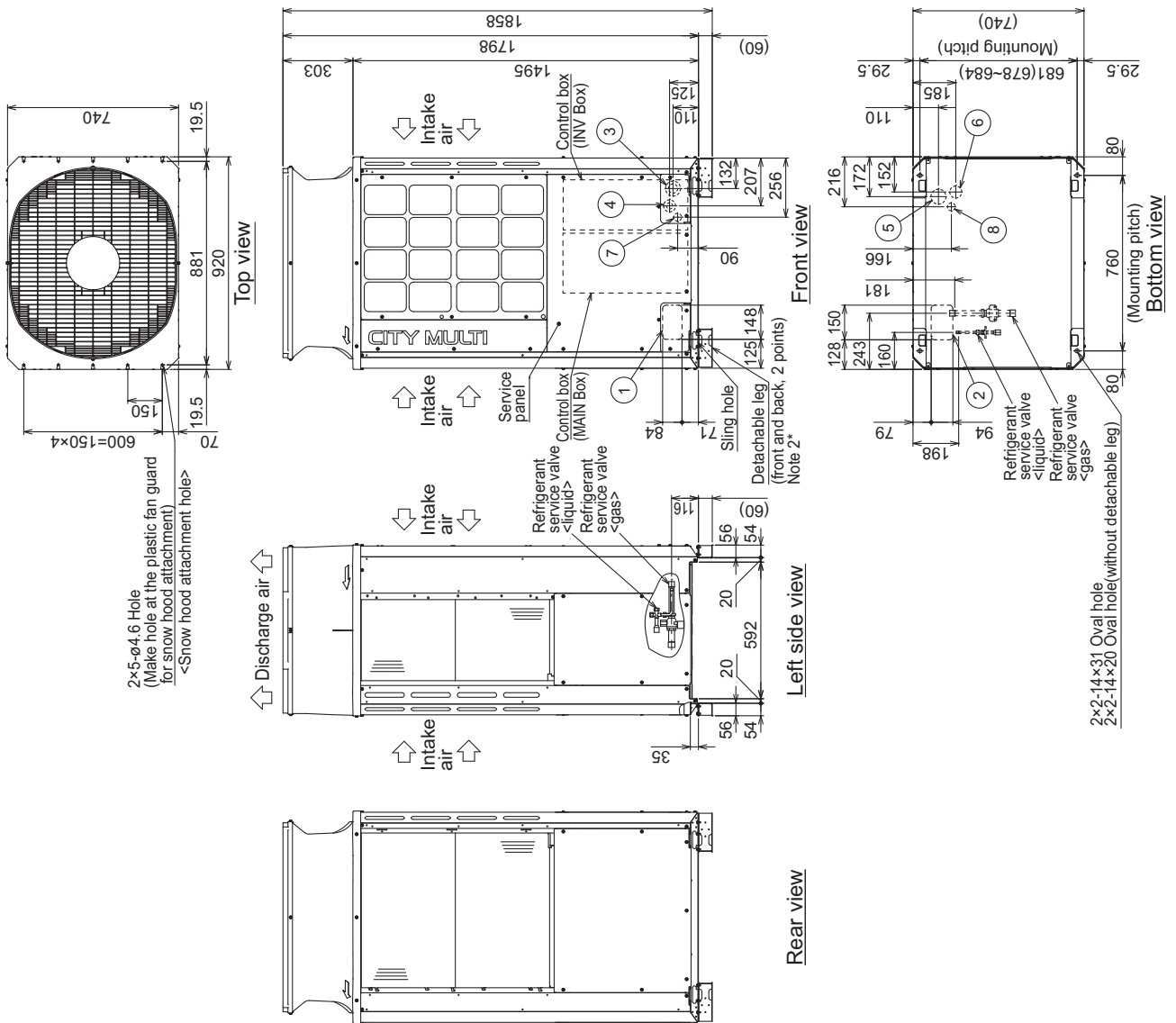

Connecting pipe specifications

Model	Refrigerant pipe		Service valve	
	Liquid	Gas	Liquid	Gas
EP200	ø9.52 Brazed			
EP250	ø9.52 Brazed (ø12.7 Brazed) ^{*1, *3}	ø22.2 Brazed	ø9.52	ø22.2
EP300	ø9.52 Brazed (ø12.7 Brazed) ^{*1, *2, *4}	ø28.58 Brazed ^{*1}		

- *1 Connect the refrigerant pipe to the service valve according to the Installation Manual.
 *2 Indicates dimensions and connection specifications in the case the unit is used in combination with other outdoor units.
 *3 Furthest piping length (OU from IU) ≥ 90m
 *4 Furthest piping length (OU from IU) ≥ 40m

NO.	Usage	Specifications
①	For pipes	Front through hole 148 x 84 Knockout hole
②		Bottom through hole 150 x 94 Knockout hole
③	For wires	Front through hole ø65 or ø40 Knockout hole
④		Front through hole ø62 or ø27 Knockout hole
⑤		Bottom through hole ø65 Knockout hole
⑥		Bottom through hole ø52 Knockout hole
⑦	For transmission cables	Front through hole ø34 Knockout hole
⑧		Bottom through hole ø34 Knockout hole

PUHY-EP200, 250, 300YNW-A2 (-BS)

Unit: mm

1. Required space around the unit

● In case of single installation

① Secure enough space around the unit as shown in the figure below.

· With a space of at least 300mm to the wall on the back of the unit

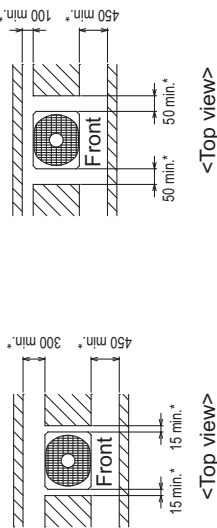

<Top view>

② When the height of the walls on the front, back or on the sides <H> exceeds the wall height limit as defined below

add half of the height that exceeds the height limit <h/2> to the figures that are marked with an asterisk(*)

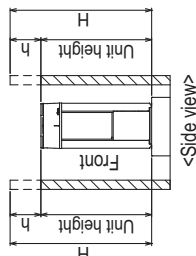

<Side view>

<Wall height limit> Front :Up to the unit height
Back :Up to the unit height
Side :Up to the unit height

2. Foundation work

- Take into consideration the surface strength, water drainage route, piping route, and wiring route when preparing the installation site.
<Note that the drain water comes out of the unit during operation.>
- Build the foundation in such way that the corner of the installation leg is securely supported as shown in the right figure.(Fig.A,B)
When using a rubber isolating cushion, please ensure it is large enough to cover the entire width of each of the unit's legs.
- The protrusion length of the anchor bolt must not exceed 30mm.(Fig.A,B)
- Use four fixing plates as shown in the right figure <field supply required> when using M12 hole-in anchor bolts <field supply required>.(Fig.C,D)
- To prevent small animals and water and snow from entering the unit and damaging its parts, close the gap around the edges of through holes for pipes and wires with filler plates <field supply required>.
- When the pipes or cables are routed at the bottom of the unit, make sure that the through hole at the base of the unit does not get blocked with the installation base.
- Refer to the Installation Manual when installing units on an installation base.

● In case of collective installation

- When multiple units are installed adjacent to each other, secure enough space to allow for air circulation and walkway between groups of units as shown in the figures below.
- At least two sides must be left open.
- As with the single installation, add half of the height that exceeds the height limit <h/2> to the figures that are marked with an asterisk(*)
- If there is a wall at both the front and the rear of the unit, install up to six units consecutively in the side direction and provide a space of 1000mm or more as inlet space/ passage space for each six units.

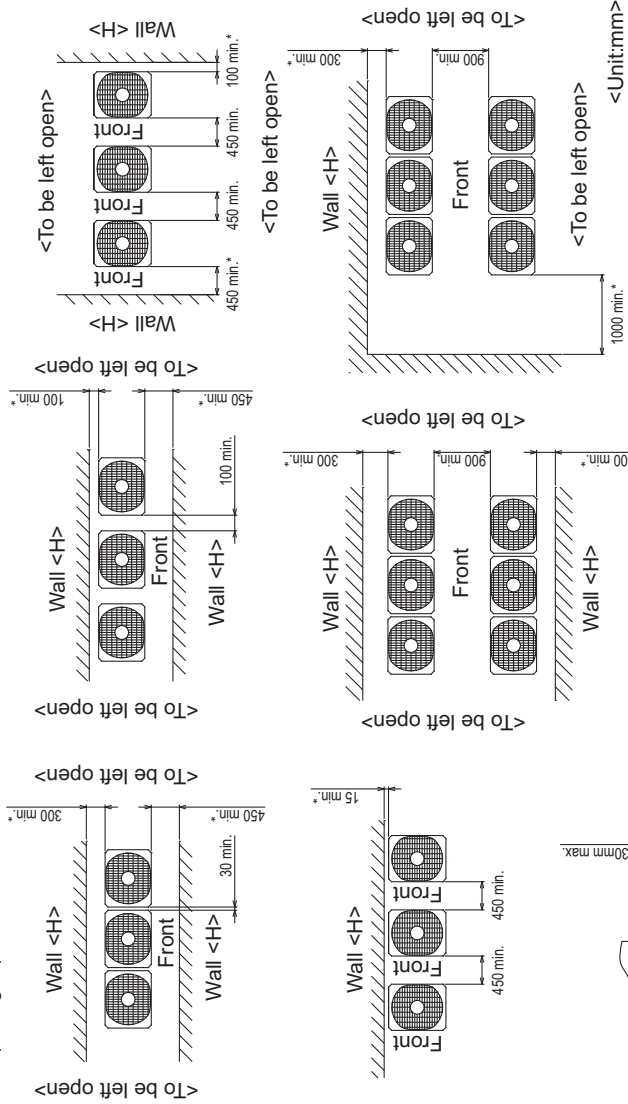

Fig.A (without detachable legs)

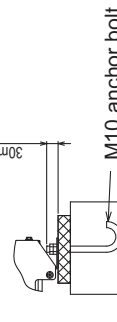
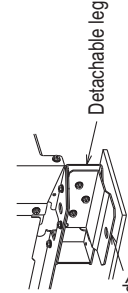

Fig.C (without detachable legs)



Fig.D (with detachable legs)



Unit: mm

PUHY-EP350, 400, 450YNW-A2 (-BS)

- Note 1. Please refer to the next page for information regarding necessary spacing around the unit and foundation work.
 2. The detachable leg can be removed at site.
 3. At brazing of pipes, wrap the refrigerant service valve with wet cloth and keep the temperature of refrigerant service valve under 120°C.

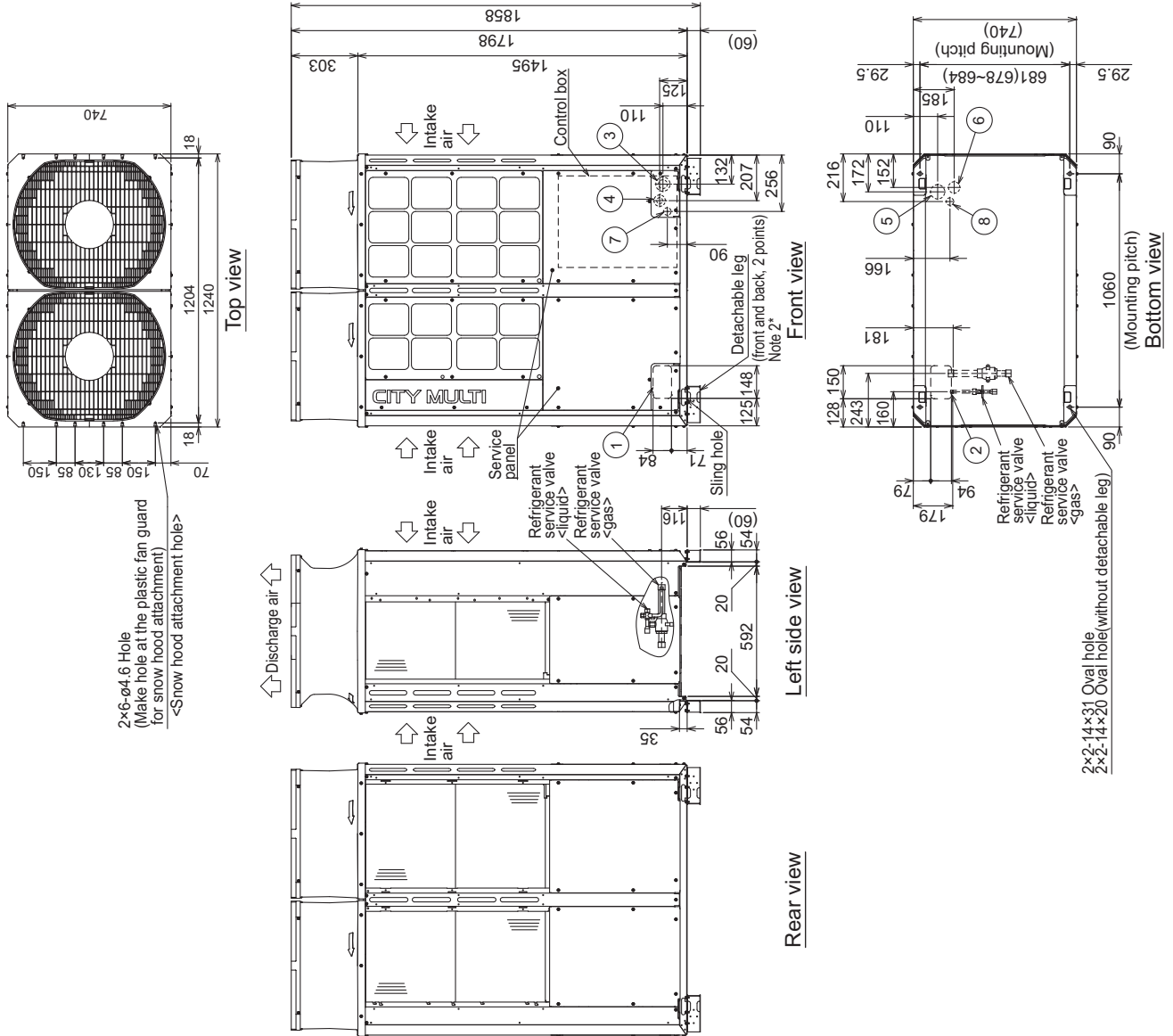

Connecting pipe specifications

Model	Refrigerant pipe		Service valve	
	Liquid	Gas	Liquid	Gas
EP350	ø12.7 Brazed	ø28.58 Brazed	ø12.7	ø28.58
EP400	ø12.7 Brazed (ø15.88 Brazed)*1,*2	ø28.58 Brazed	ø12.7	ø28.58
EP450	ø15.88 Brazed *1	ø28.58 Brazed	ø12.7	ø28.58

*1 Connect the refrigerant pipe to the service valve according to the Installation Manual.
 *2 Indicates dimensions and connection specifications in the case the unit is used in combination with other outdoor units. (Except for EP650)

NO.	Usage	Specifications
①	For pipes	Front through hole 148 x 84 Knockout hole
②		Bottom through hole 150 x 94 Knockout hole
③	For wires	Front through hole ø65 or ø40 Knockout hole
④		Front through hole ø52 or ø27 Knockout hole
⑤		Bottom through hole ø65 Knockout hole
⑥		Bottom through hole ø52 Knockout hole
⑦	For transmission cables	Front through hole ø34 Knockout hole
⑧		Bottom through hole ø34 Knockout hole

PUHY-EP350, 400, 450YNW-A2 (-BS)

Unit: mm

1. Required space around the unit

● In case of single installation

① Secure enough space around the unit as shown in the figure below.

- With a space of at least 300mm to the wall on the back of the unit
- With a space of at least 100mm to the wall on the back of the unit

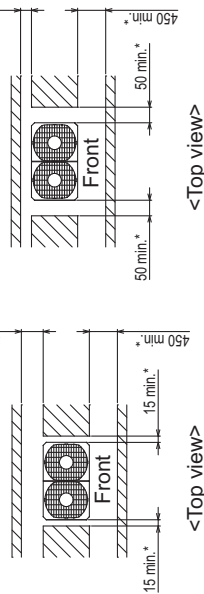

<Top view>

② When the height of the walls on the front, back or on the sides <H> exceeds the wall height limit as defined below add half of the height that exceeds the height limit <h/2> to the figures that are marked with an asterisk(*)

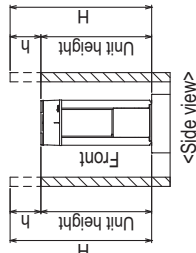

<Side view>

- <Wall height limit> Front :Up to the unit height
- Back :Up to the unit height
- Side :Up to the unit height

2.Foundation work

- Take into consideration the surface strength, water drainage route, piping route, and wiring route when preparing the installation site.
 - <Note that the drain water comes out of the unit during operation.>
- Build the foundation in such way that the corner of the installation leg is securely supported as shown in the right figure.(Fig.A,B)
 - When using a rubber isolating cushion, please ensure it is large enough to cover the entire width of each of the unit's legs.
- The protrusion length of the anchor bolt must not exceed 30mm.(Fig.A,B)
- Use four fixing plates as shown in the right figure <field supply required> when using M12 hole-in anchor bolts <field supply required> (Fig.C,D)
- To prevent small animals and water and snow from entering the unit and damaging its parts, close the gap around the edges of through holes for pipes and wires with filler plates <field supply required>.
- When the pipes or cables are routed at the bottom of the unit, make sure that the through hole at the base of the unit does not get blocked with the installation base.
- Refer to the Installation Manual when installing units on an installation base.

● In case of collective installation

- When multiple units are installed adjacent to each other, secure enough space to allow for air circulation and walkway between groups of units as shown in the figures below.
- At least two sides must be left open.
- As with the single installation, add half of the height that exceeds the height limit <h/2> to the figures that are marked with an asterisk(*)
- If there is a wall at both the front and the rear of the unit, install up to six units consecutively in the side direction and provide a space of 1000mm or more as inlet space/ passage space for each six units.

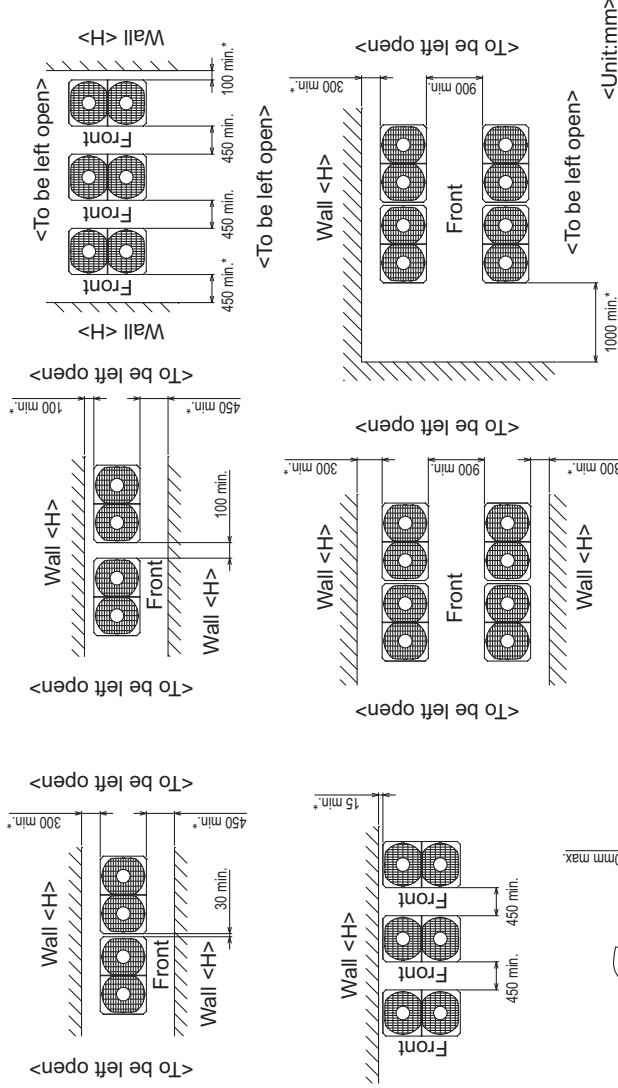

Fig.A (without detachable legs)

M10 anchor bolt <field supply required>

Fig.C (without detachable legs)

Fixing plate <field supply required>

Fig.B (with detachable legs)

Detachable leg

Fig.D (with detachable legs)

Fixing plate <field supply required>

Fig.C (with detachable legs)

M10 anchor bolt <field supply required>

Fig.B (with detachable legs)

Detachable leg

PUHY-EP500YNW-A2 (-BS)

Unit: mm

- Note 1. Please refer to the next page for information regarding necessary spacing around the unit and foundation work.
 2. The detachable leg can be removed at site.
 3. At brazing of pipes, wrap the refrigerant service valve with wet cloth and keep the temperature of refrigerant service valve under 120°C.

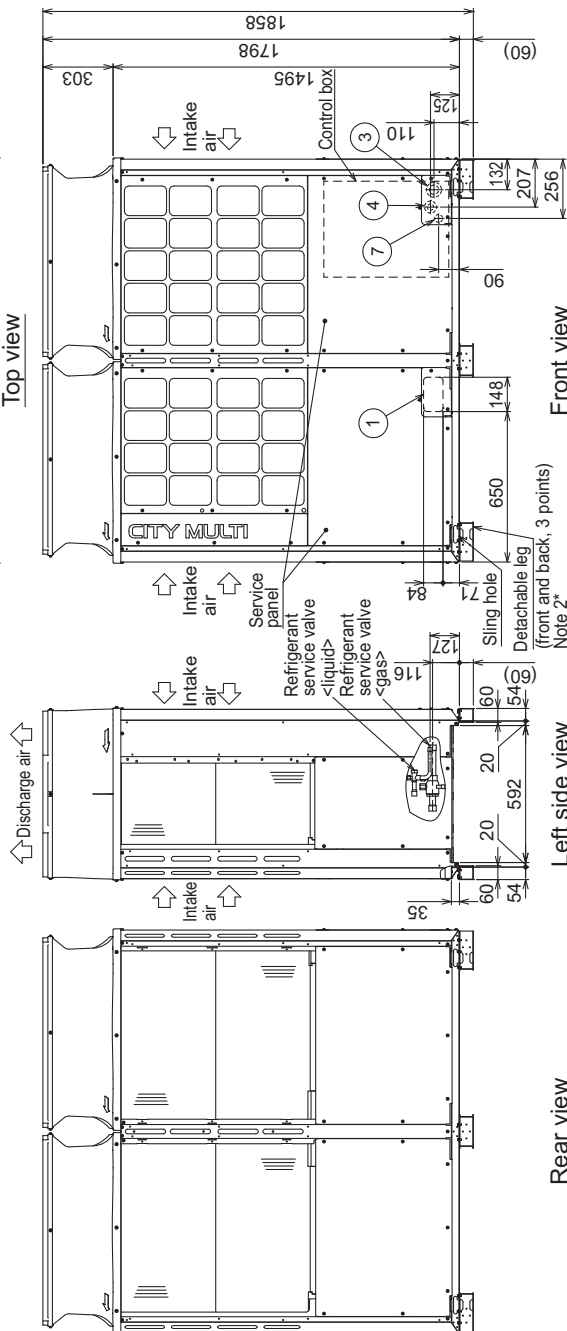
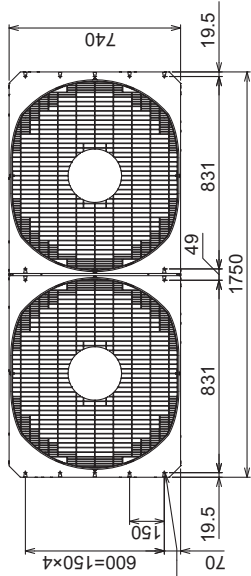

Connecting pipe specifications

Model	Refrigerant pipe		Service valve	
	Liquid	Gas	Liquid	Gas
EP500	ø15.88 Braze	ø28.58 Braze	ø15.88	ø28.58

NO.	Usage	Specifications	
		Front through hole	Bottom through hole
①	For pipes	148 x 84 Knockout hole	150 x 94 Knockout hole
②		150 x 94 Knockout hole	ø65 or ø40 Knockout hole
③	For wires	ø65 or ø40 Knockout hole	ø52 or ø27 Knockout hole
④		ø52 or ø27 Knockout hole	ø65 Knockout hole
⑤	For transmission cables	ø65 Knockout hole	ø52 Knockout hole
⑥		ø52 Knockout hole	ø34 Knockout hole
⑦	Bottom through hole	ø34 Knockout hole	ø34 Knockout hole
⑧		ø34 Knockout hole	ø34 Knockout hole

Front view

Left side view

Rear view

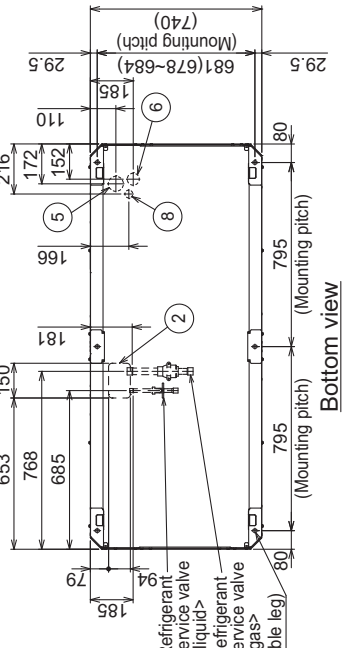

Bottom view

PUHY-EP500YNW-A2 (-BS)

Unit: mm

● In case of collective installation

- When multiple units are installed adjacent to each other, secure enough space to allow for air circulation and walkway between groups of units as shown in the figures below.
- At least two sides must be left open.
- As with the single installation, add half of the height that exceeds the height limit $<h/2>$ to the figures that are marked with an asterisk(*).
- If there is a wall at both the front and the rear of the unit, install up to three units consecutively in the side direction and provide a space of 1000mm or more as inlet space/ passage space for each three units.

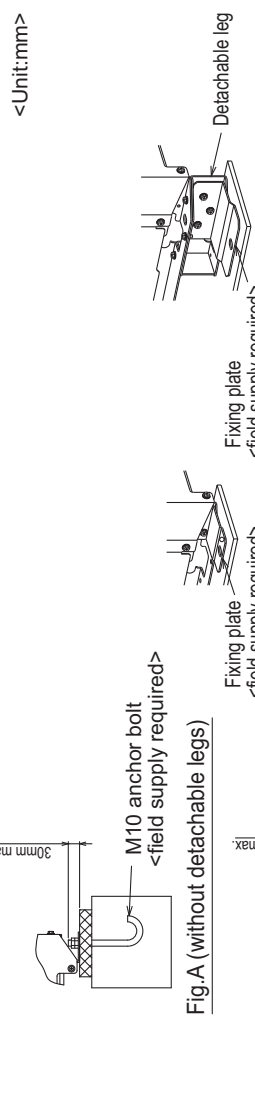
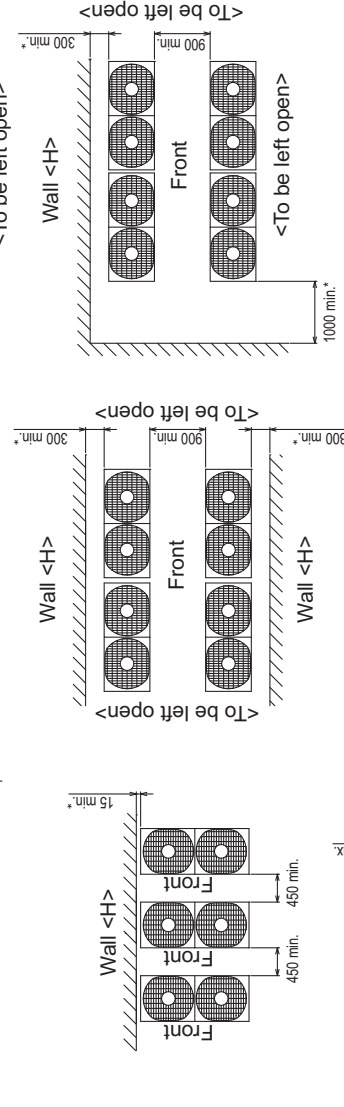
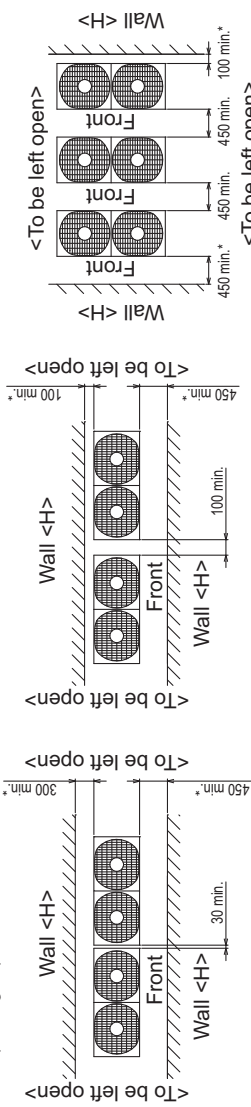

1. Required space around the unit

● In case of single installation

- Secure enough space around the unit as shown in the figure below.
 - With a space of at least 300mm to the wall on the back of the unit

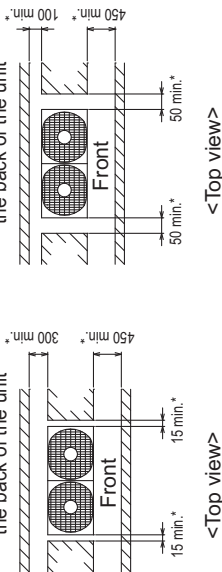

- When the height of the walls on the front, back or on the sides $<H>$ exceeds the wall height limit as defined below add half of the height that exceeds the height limit $<h/2>$ to the figures that are marked with an asterisk(*).

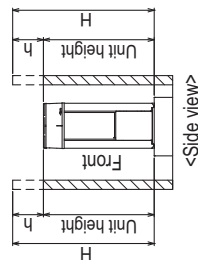

<Wall height limit> Front :Up to the unit height
 Back :Up to the unit height
 Side :Up to the unit height

2. Foundation work

- Take into consideration the surface strength, water drainage route, piping route, and wiring route when preparing the installation site.
 - Note that the drain water comes out of the unit during operation. >
- Build the foundation in such way that the corner of the installation leg is securely supported as shown in the right figure (Fig.A,B)
 - When using a rubber isolating cushion, please ensure it is large enough to cover the entire width of each of the unit's legs.
- The protrusion length of the anchor bolt must not exceed 30mm. (Fig.A,B)
- Use six fixing plates as shown in the right figure <field supply required> when using M12 hole-in anchor bolts <field supply required>. (Fig.C,D)
- To prevent small animals and water and snow from entering the unit and damaging its parts, close the gap around the edges of through holes for pipes and wires with filler plates <field supply required>.
- When the pipes or cables are routed at the bottom of the unit, make sure that the through hole at the base of the unit does not get blocked with the installation base.
- Refer to the Installation Manual when installing units on an installation base.

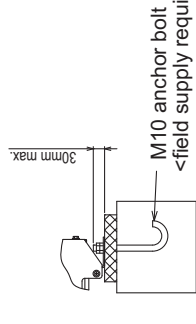

Fig.A (without detachable legs)

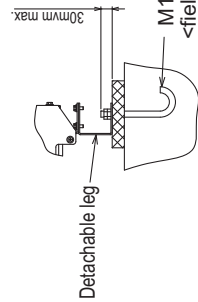

Fig.B (with detachable legs)



Fig.C (without detachable legs)

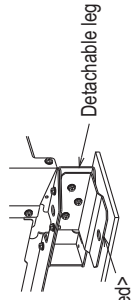
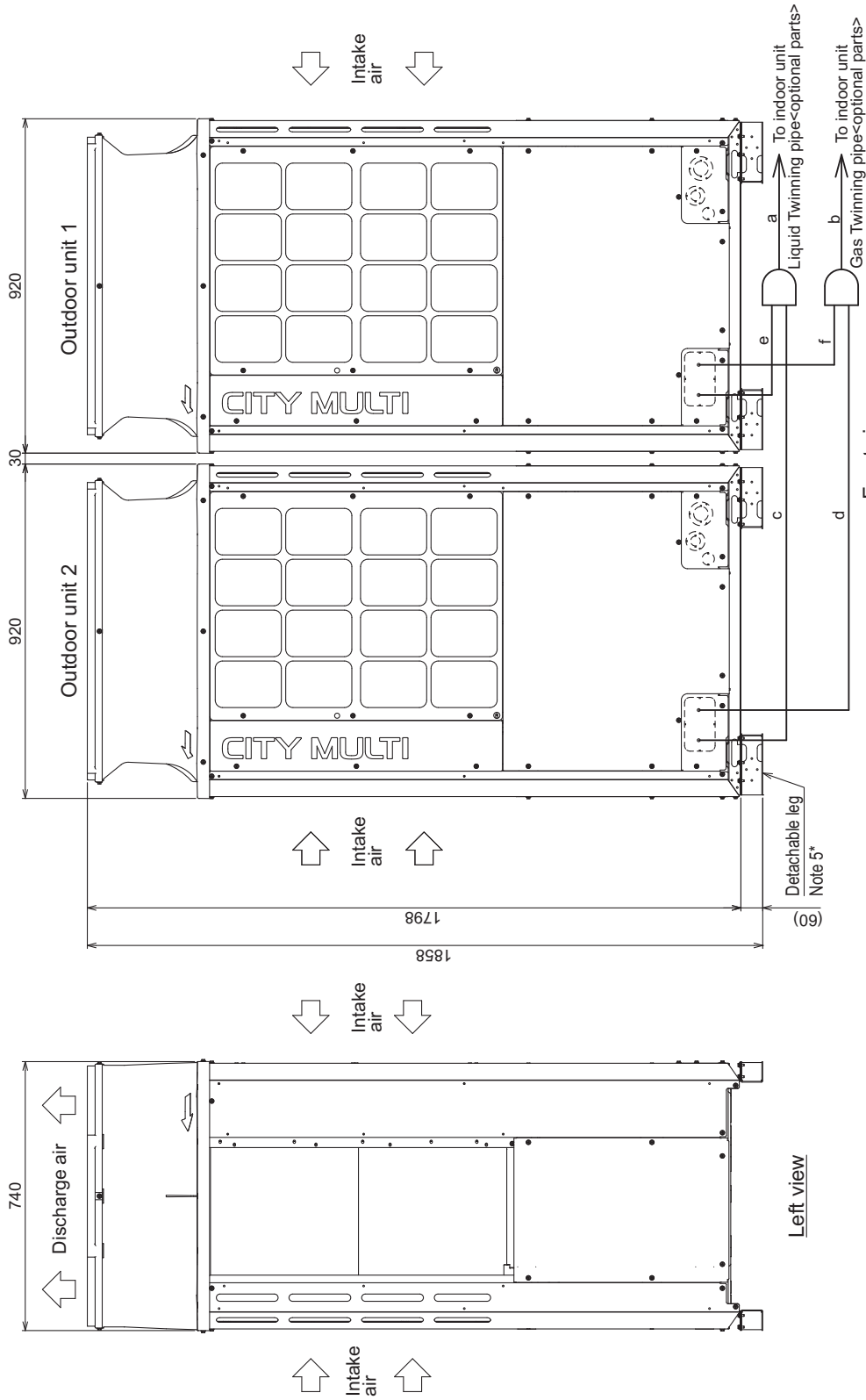

Fig.D (with detachable legs)

PUHY-EP400, 450, 500, 550, 600YSNW-A2 (-BS)

Unit: mm



Front view

Left view

Twinning pipe connection size

Package unit name	PUHY-EP400YSNW-A2(-BS)	PUHY-EP450YSNW-A2(-BS)	PUHY-EP500YSNW-A2(-BS)	PUHY-EP550YSNW-A2(-BS)	PUHY-EP600YSNW-A2(-BS)
Outdoor unit 1	PUHY-EP200YNNW-A2(-BS)	PUHY-EP250YNNW-A2(-BS)	PUHY-EP300YNNW-A2(-BS)	PUHY-EP350YNNW-A2(-BS)	PUHY-EP400YNNW-A2(-BS)
Outdoor unit 2	PUHY-EP200YNNW-A2(-BS)	PUHY-EP250YNNW-A2(-BS)	PUHY-EP300YNNW-A2(-BS)	PUHY-EP350YNNW-A2(-BS)	PUHY-EP400YNNW-A2(-BS)
Outdoor Twinning Kit(optional parts)	CMY-Y100VBK3				
Indoor unit-Twinning pipe	Liquid a		Gas b		
	ø12.7		ø15.88		
			ø28.58		

Unit model	Liquid c or e	Gas d or f
EP200	ø9.52	ø22.2
EP250	ø9.52	ø22.2
EP300	ø12.7	ø28.58

- Note 1. Connect the pipes as shown in the figure above. Refer to the table above for the pipe size.
 2. Twinning pipes must be installed horizontally using a level vessel.
 3. Be sure to see the Installation Manual for details of Twinning pipe installation.
 3. The pipe section before the Twinning pipe (sections "a" and "b" in the figure) must have at least 500mm of straight section.
 (*including the straight pipe that is supplied with the Twinning pipe).
 4. Only use the Twinning pipe by Mitsubishi (optional parts).
 5. The detachable leg can be removed at site.

PUHY-EP650YSNW-A2 (-BS)

Unit: mm

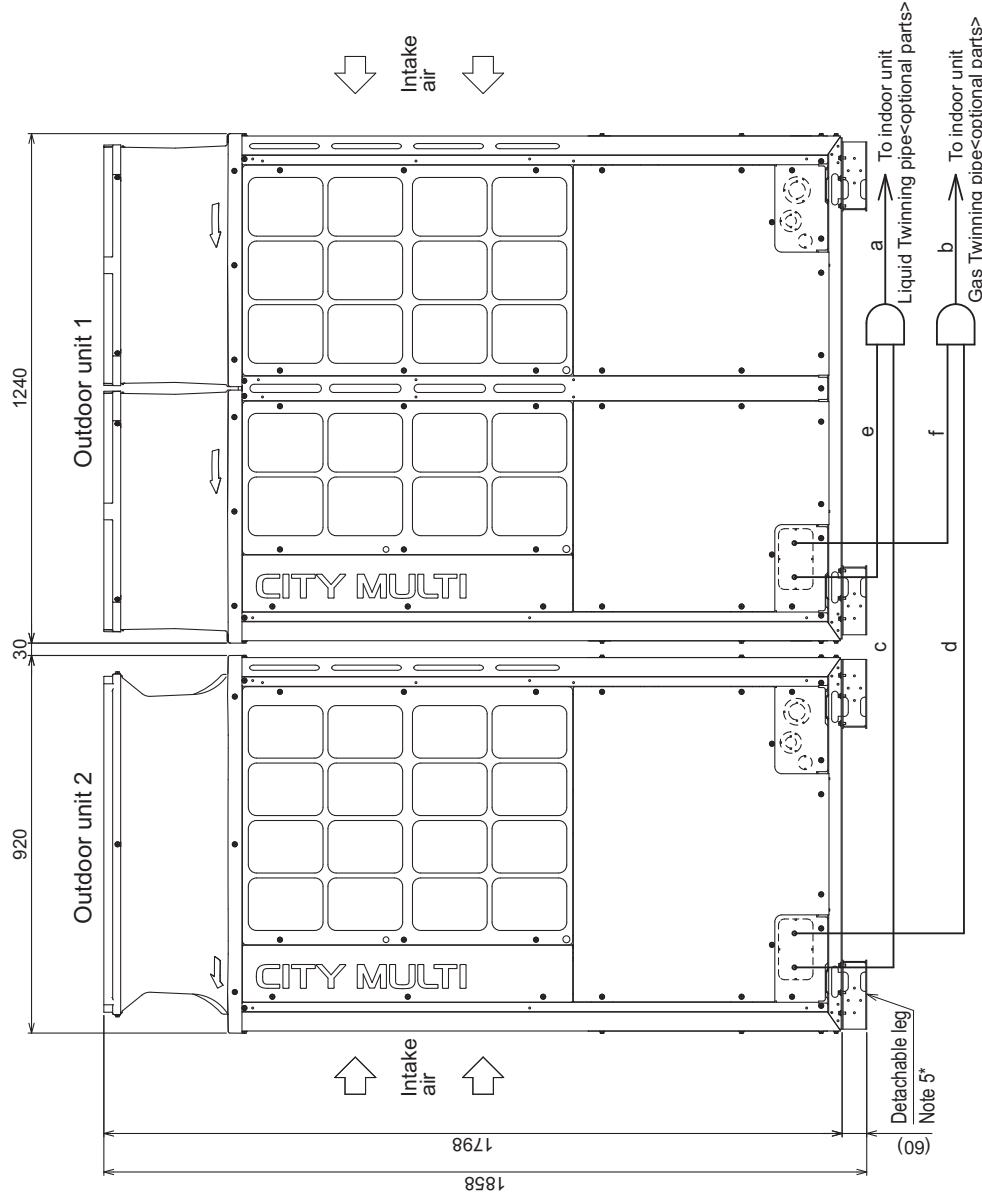

Front view

Twinning pipe connection size		Package unit name	PUHY-EP650YSNW-A2(-BS)
Outdoor unit 1	Outdoor unit 2	Component unit name	PUHY-EP400Y/NW-A2(-BS)
Outdoor Twinning Kit(optional parts)	CMY-Y100VBK3	Outdoor Twinning Kit(optional parts)	CMY-Y100VBK3
Indoor unit~ Twinning pipe		Liquid	ø15.88
		Gas	ø28.58

Unit model	Liquid core	Gas d or f
EP250	ø9.52	ø22.2
EP400	ø12.7	ø28.58

Note 1. Connect the pipes as shown in the figure above. Refer to the table above for the pipe size.

2. Twinning pipes must be installed horizontally using a level vessel.

Be sure to see the Installation Manual for details of Twinning pipe installation.

3. The pipe section before the Twinning pipe (sections "a" and "b" in the figure) must have at least 500mm of straight section

(*including the straight pipe that is supplied with the Twinning pipe).

4. Only use the Twinning pipe by Mitsubishi (optional parts).

5. The detachable leg can be removed at site.

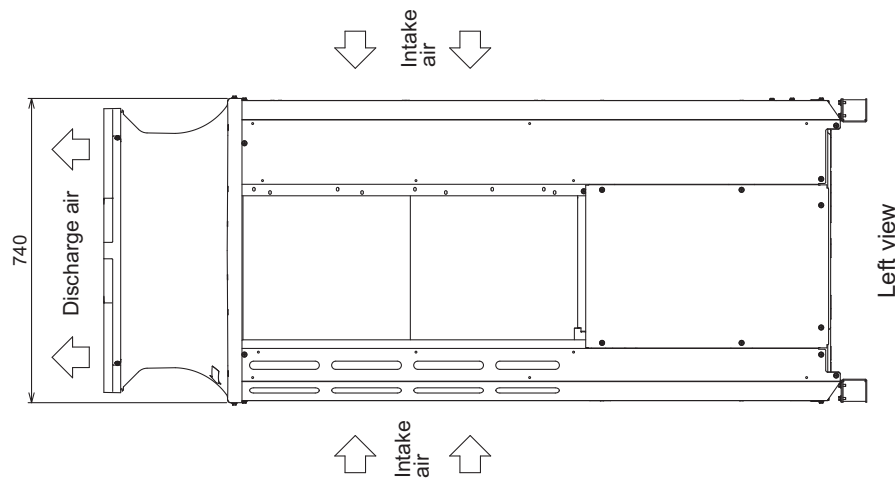

Left view

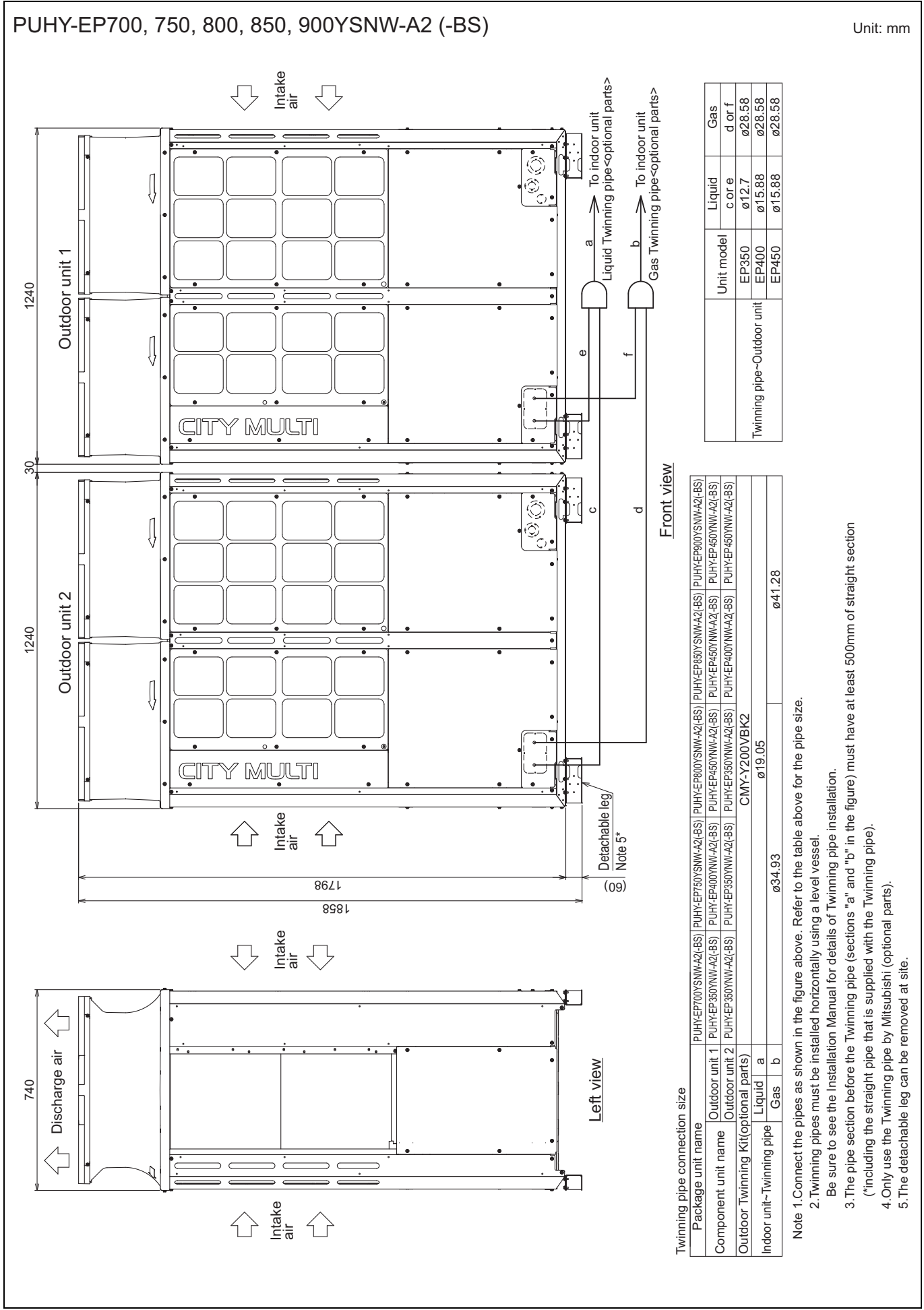

PUHY-EP-Y(S)NW-A2

PUHY-EP950, 1000, 1050YSNW-A2 (-BS)

Unit: mm

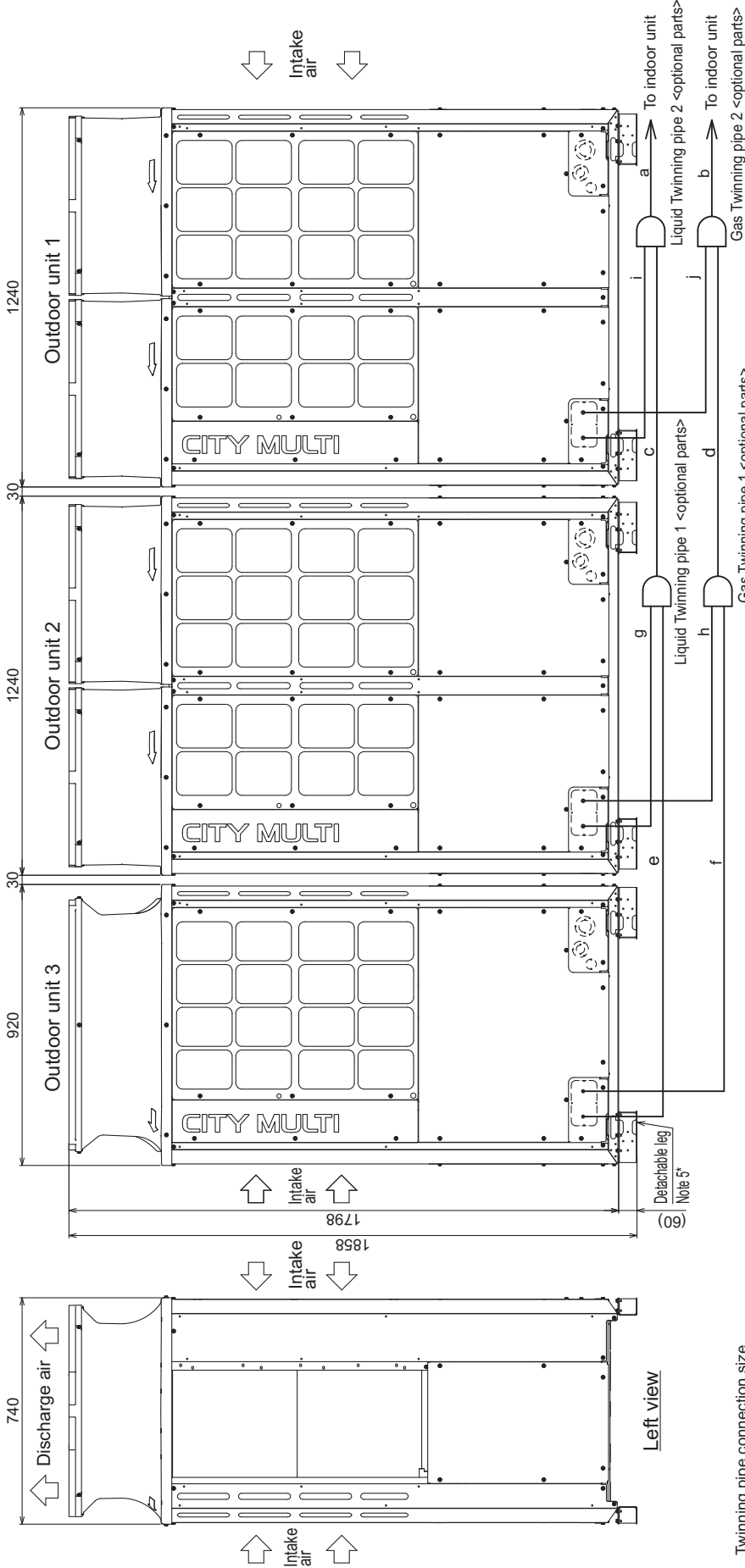

Front view

Left view

Unit model	Liquid e or g or i	Gas f or h or j
EP250	ø9.52	ø22.2
EP350	ø12.7	ø28.58
EP400	ø15.88	ø28.58

Package unit name	PUHY-EP950YSNW-A2(-BS)	PUHY-EP1000YSNW-A2(-BS)	PUHY-EP1050YSNW-A2(-BS)
Outdoor unit 1	PUHY-EP350YNW-A2(-BS)	PUHY-EP400YNW-A2(-BS)	PUHY-EP400YNW-A2(-BS)
Outdoor unit 2	PUHY-EP350YNW-A2(-BS)	PUHY-EP350YNW-A2(-BS)	PUHY-EP400YNW-A2(-BS)
Outdoor unit 3	PUHY-EP250YNW-A2(-BS)	PUHY-EP250YNW-A2(-BS)	PUHY-EP250YNW-A2(-BS)
Outdoor Twinning Kit(optional parts)	CMY-Y300VBK3		
Indoor unit~Twinning pipe 2	Liquid a	ø19.05	
	Gas b	ø41.28	
Twinning pipe 1~Twinning pipe 2	Liquid c	ø19.05	
	Gas d	ø34.93	

- Note 1. Connect the pipes as shown in the figure above. Refer to the table above for the pipe size.
 2. Twinning pipes must be installed horizontally using a level vessel.
 Be sure to see the Installation Manual for details of Twinning pipe installation.
 3. The pipe section before the Twinning pipe (sections "a", "b", "c" and "d" in the figure) must have at least 500mm of straight section (*including the straight pipe that is supplied with the Twinning pipe).
 4. Only use the Twinning pipe by Mitsubishi (optional parts).
 5. The detachable leg can be removed at site.

PUHY-EP1100, 1150, 1200, 1250, 1300, 1350YSNW-A2 (-BS)

Unit: mm

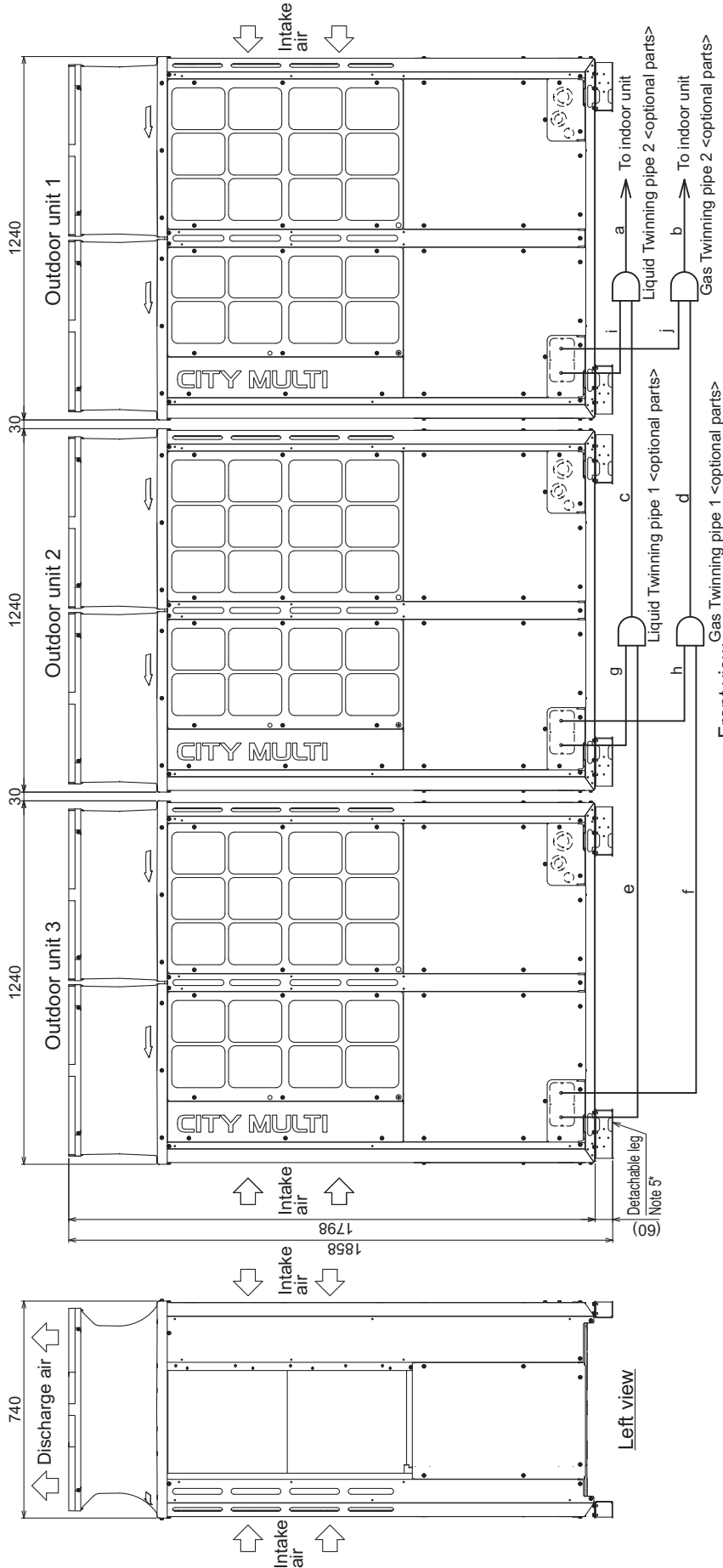

Twinning pipe connection size

Package unit name	PUHY-EP1100YSNW-A2(-BS)	PUHY-EP150YSNW-A2(-BS)	PUHY-EP200YSNW-A2(-BS)	PUHY-EP250YSNW-A2(-BS)	PUHY-EP300YSNW-A2(-BS)	PUHY-EP350YSNW-A2(-BS)	PUHY-EP400YSNW-A2(-BS)	PUHY-EP450YSNW-A2(-BS)	PUHY-EP500YSNW-A2(-BS)			
Outdoor unit 1	PUHY-EP1100YSNW-A2(-BS)	PUHY-EP150YSNW-A2(-BS)	PUHY-EP200YSNW-A2(-BS)	PUHY-EP250YSNW-A2(-BS)	PUHY-EP300YSNW-A2(-BS)	PUHY-EP350YSNW-A2(-BS)	PUHY-EP400YSNW-A2(-BS)	PUHY-EP450YSNW-A2(-BS)	PUHY-EP500YSNW-A2(-BS)			
Outdoor unit 2	PUHY-EP1150YSNW-A2(-BS)	PUHY-EP155YSNW-A2(-BS)	PUHY-EP205YSNW-A2(-BS)	PUHY-EP255YSNW-A2(-BS)	PUHY-EP305YSNW-A2(-BS)	PUHY-EP355YSNW-A2(-BS)	PUHY-EP405YSNW-A2(-BS)	PUHY-EP455YSNW-A2(-BS)	PUHY-EP505YSNW-A2(-BS)			
Outdoor unit 3	PUHY-EP1200YSNW-A2(-BS)	PUHY-EP160YSNW-A2(-BS)	PUHY-EP210YSNW-A2(-BS)	PUHY-EP260YSNW-A2(-BS)	PUHY-EP310YSNW-A2(-BS)	PUHY-EP360YSNW-A2(-BS)	PUHY-EP410YSNW-A2(-BS)	PUHY-EP460YSNW-A2(-BS)	PUHY-EP510YSNW-A2(-BS)			
Outdoor Twinning Kit(optional parts)	CMY-Y300VBK3											
Indoor unit-Twinning pipe 2	Liquid	a	ø19.05							Gas	i	ø28.58
Twinning pipe 1-Twinning pipe 2	Gas	b	ø41.28							Liquid	c	ø19.05
	Gas	d	ø34.93							Gas	j	ø28.58

- Note 1. Connect the pipes as shown in the figure above. Refer to the table above for the pipe size.
 2. Twinning pipes must be installed horizontally using a level vessel.
 Be sure to see the Installation Manual for details of Twinning pipe installation.
 3. The pipe section before the Twinning pipe (sections "a", "b", "c" and "d" in the figure) must have at least 500mm of straight section (*including the straight pipe that is supplied with the Twinning pipe).
 4. Only use the Twinning pipe by Mitsubishi (optional parts).
 5. The detachable leg can be removed at site.

Unit model	Liquid	Gas
EP350	ø12.7	ø28.58
EP400	ø15.88	ø28.58
EP450	ø15.88	ø28.58

PUHY-EP200, 250, 300YNW-A2 (-BS)

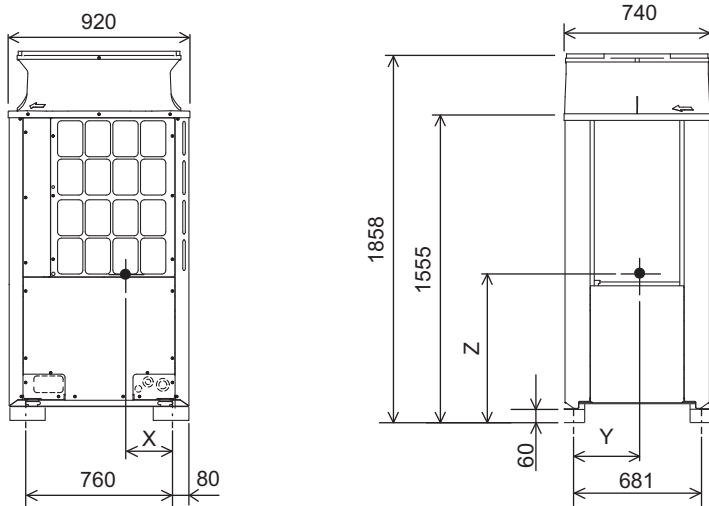

Unit: mm

Model	X	Y	Z
PUHY-EP200YNW-A2(-BS)	354	341	687
PUHY-EP250YNW-A2(-BS)	354	341	687
PUHY-EP300YNW-A2(-BS)	348	338	680

PUHY-EP350, 400, 450YNW-A2 (-BS)

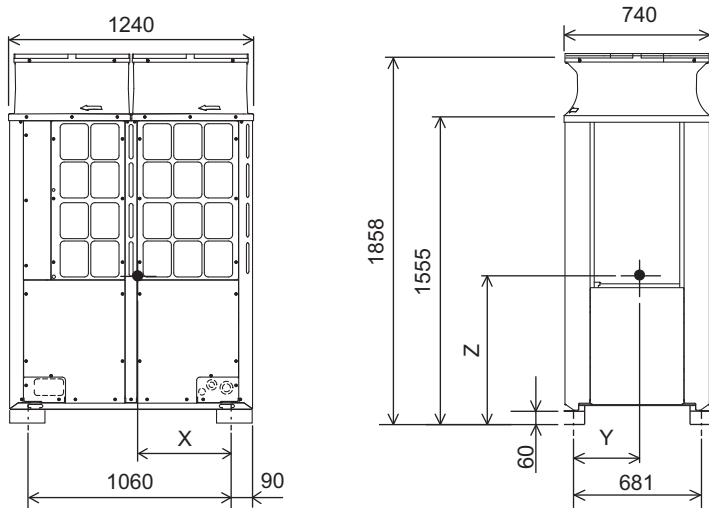

Unit: mm

Model	X	Y	Z
PUHY-EP350YNW-A2(-BS)	491	347	729
PUHY-EP400YNW-A2(-BS)	492	347	754
PUHY-EP450YNW-A2(-BS)	492	347	754

PUHY-EP500YNW-A2 (-BS)

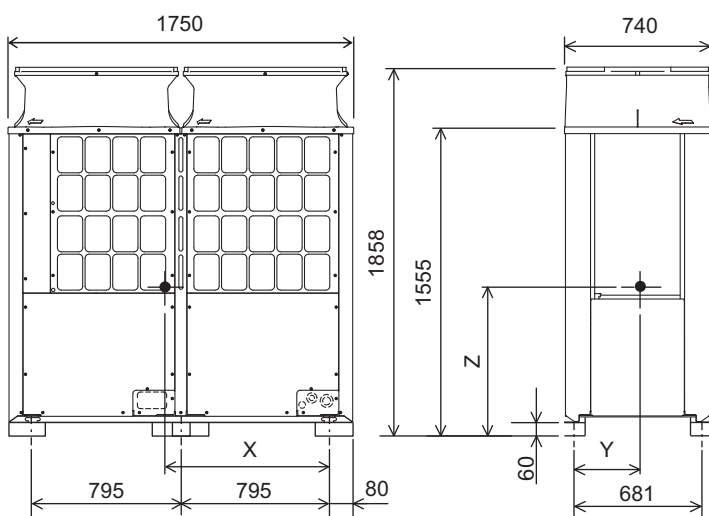

Unit: mm

Model	X	Y	Z
PUHY-EP500YNW-A2(-BS)	859	312	728