

PQHY-P200, 250, 300YLM-A1

Unit: mm

- <Accessories>
- Refrigerant (Liquid) conn. pipe 1pc. (P200/P250/P300 ; Packaged in the accessory kit)
 - Refrigerant (Gas) conn. elbow 1pc. (P200/P250/P300 ; Packaged in the accessory kit)
 - Water stopper(Liquid,Gas) 1pc. each (P200/P250/P300 ; Packaged in the accessory kit)
 - Sealing material for water stopper (Liquid,Gas) 1pc. each (P200/P250/P300 ; Packaged in the accessory kit)
 - Sealing material for field piping (Liquid,Gas) 1pc. each (P200/P250/P300 ; Packaged in the accessory kit)
 - Sealing material for drain socket 1pc. (P200/P250/P300 ; Packaged in the accessory kit)
 - Pipe cover for gas 1pc. (P200/P250/P300 ; Packaged in the accessory kit)

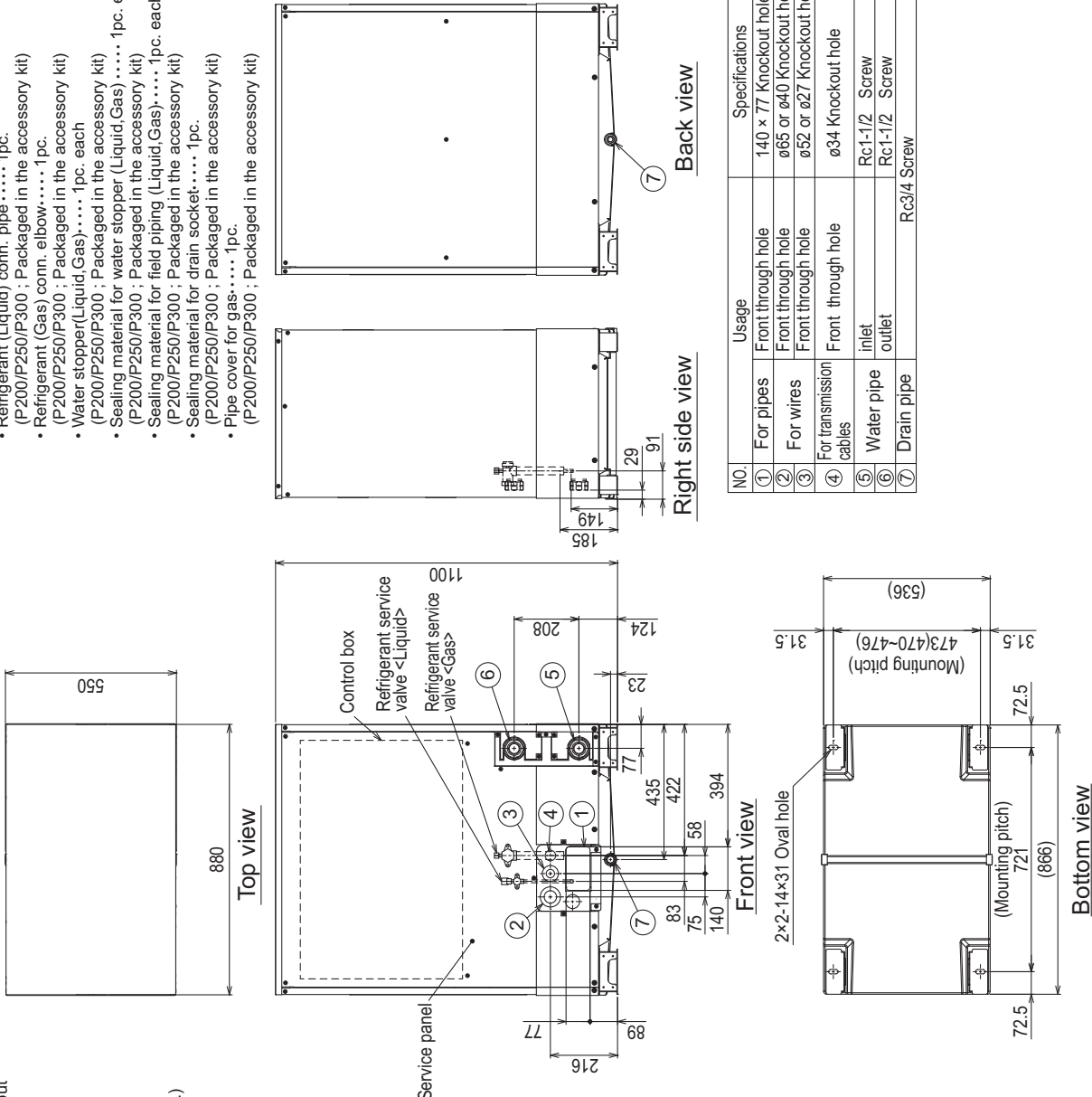

NO.	Usage	Specifications
①	For pipes	140 x 77 Knockout hole
②	For wires	ø65 or ø40 Knockout hole
③	For transmission cables	ø52 or ø27 Knockout hole
④	Water pipe inlet	ø34 Knockout hole
⑤	Water pipe outlet	Rc1-1/2 Screw
⑥	Drain pipe	Rc1-1/2 Screw
⑦		Rc3/4 Screw

- Note1. Close a hole of the water piping, the refrigerant piping, the power supply, and the control wiring and unused knockout holes with the putty etc. so as not to infiltrate rain water etc. (field erection work)
- Note2. At the time of product shipment, the front side piping specification serves as the local drainage connection. When connecting on the rear side, please remove the rear side plug sealing corks, and attach a front side. Ensure there is no leak after the attachment has been fitted.
- Note3. Take notice of service space as Fig.A. (In case of single installation, 60mm or more of back space as front space makes easier access when servicing the unit from rear side.)
- Note4. If water pipes or refrigerant pipes stretch upward, required space for service and maintenance due to replacement of control box is shown in Fig.B.
- Note5. Environmental condition for installation: -20~40°C(DB) as indoor installation.
- Note6. In case the temperature around the heat source unit has possibility to drop under 0°C or the inlet-water temp. drops under 10°C, be careful for the following point to prevent the pipe burst by the water pipe freeze-up.
- Add brine to water circuit.
 - Circulate the water all the time even if the heat source unit is not in operation.
 - Drain the water from inside of the heat source unit when the heat source unit will not operate for a long term.
- Note7. Ensure that the drain piping is downward with a pitch of more than 1/100.
- Note8. At brazing of pipes, wrap the refrigerant service valve with wet cloth and keep the temperature of refrigerant service valve under 120°C.

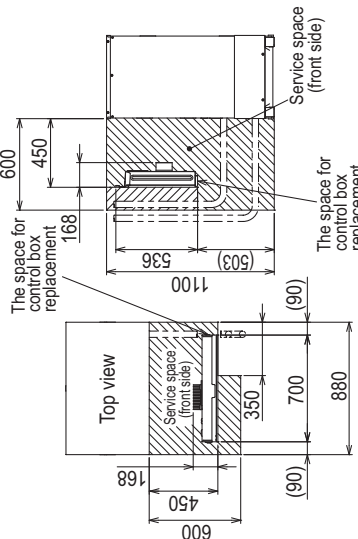

Fig.A

Fig.B

Connecting pipe specifications

Model	Refrigerant pipe		Service valve		Ø25.4
	Liquid	Gas	Liquid	Gas	
PQHY-P200YLM-A1	ø9.52 Brazeed *1	ø19.05 Brazeed *1, *4	ø9.52 Brazeed *1, *4	ø9.52 Brazeed *1, *4	ø25.4
PQHY-P250YLM-A1	ø9.52 Brazeed *1	ø12.7 Brazeed *2, *4	ø9.52 Brazeed *1, *4	ø9.52 Brazeed *1, *4	
PQHY-P300YLM-A1	ø9.52 Brazeed *1	ø12.7 Brazeed *3, *4	ø9.52 Brazeed *1	ø9.52 Brazeed *3, *4	

- *1. Connect by using the connecting pipes and elbow that are supplied.
- *2. Total length ≥ 90mm
- *3. Total length ≥ 40mm
- *4. Use the pipe joint(field supply) and connect to the refrigerant service valve piping.

PQHY-P350, 400, 450, 500YLM-A1

Unit: mm

PQHY-P-Y(S)LM-A1

- <Accessories>
- Refrigerant (Liquid) conn. pipe.....1pc. (P350/P400/P450/P500 ; Packaged in the accessory kit)
 - Refrigerant (Gas) conn. elbow.....1pc. (P350/P400/P450/P500 ; Packaged in the accessory kit)
 - Water stopper(Liquid,Gas).....1pc. each (P350/P400/P450/P500 ; Packaged in the accessory kit)
 - Sealing material for water stopper (Liquid,Gas).....1pc. each (P350/P400/P450/P500 ; Packaged in the accessory kit)
 - Sealing material for field piping (Liquid,Gas).....1pc. each (P350/P400/P450/P500 ; Packaged in the accessory kit)
 - Sealing material for drain socket.....1pc. (P350/P400/P450/P500 ; Packaged in the accessory kit)
 - Pipe cover for gas.....1pc. (P350/P400/P450/P500 ; Packaged in the accessory kit)
 - Sealing material for base leg (two types).....4pcs each (P350/P400/P450/P500 ; Packaged in the accessory kit)
 - Sealing material for panel.....1pc. (P350/P400/P450/P500 ; Packaged in the accessory kit)

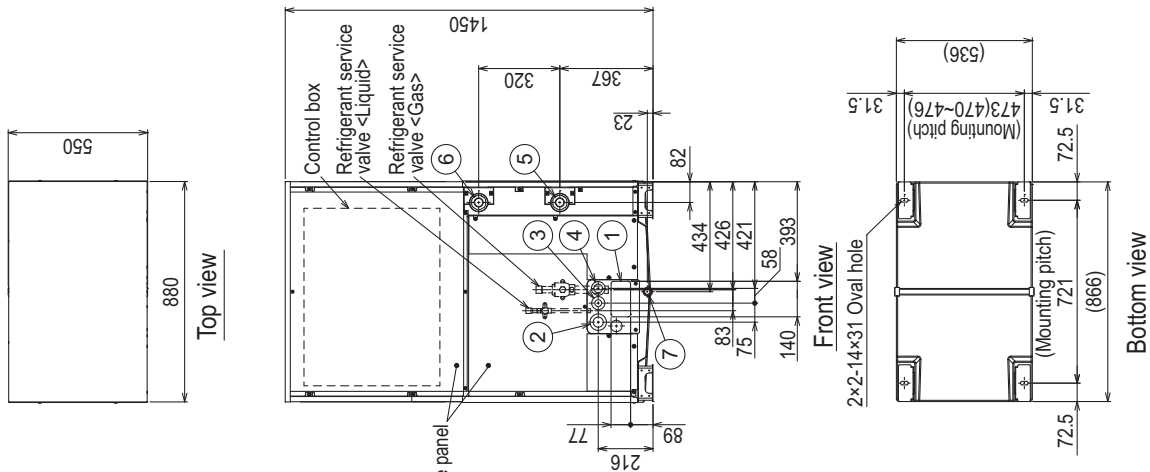

NO.	Usage	Specifications
①	For pipes	Front through hole 140 x 77 Knockout hole
②	For wires	Front through hole ø65 or ø40 Knockout hole
③	For transmission cables	Front through hole ø52 or ø27 Knockout hole
④	Water pipe inlet	ø34 Knockout hole
⑤	Water pipe outlet	Rc1-1/2 Screw
⑥	Drain pipe	Rc1-1/2 Screw
⑦		Rc3/4 Screw

- Note1. Close a hole of the water piping, the refrigerant piping, the power supply, and the control wiring and unused knockout holes with the putty etc. so as not to infiltrate rain water etc.(field erection work)
- Note2. At the time of product shipment, the front side piping specification serves as the local drainage connection. When connecting on the rear side, please remove the rear side plug sealing corks, and attach a front side. Ensure there is no leak after the attachment has been fitted.
- Note3. Take notice of service space as Fig.A. (In case of single installation, 600mm or more of back space as front space makes easier access when servicing the unit from rear side.)
- Note4. If water pipes or refrigerant pipes stretch upward, required space for service and maintenance due to replacement of control box is shown in Fig.B.
- Note5. Environmental condition for installation; -20~40°C(DB) as indoor installation.
- Note6. In case the temperature around the heat source unit has possibility to drop under 0°C or the inlet-water temp. drops under 10°C, be careful for the following point to prevent the pipe burst by the water pipe freeze-up.
- Add brine to water circuit.
 - Circulate the water all the time even if the heat source unit is not in operation.
 - Drain the water from inside of the heat source unit when the heat source unit will not operate for a long term.
- Note7. Ensure that the drain piping is downward with a pitch of more than 1/100.
- Note8. At brazing of pipes, wrap the refrigerant service valve with wet cloth and keep the temperature of refrigerant service valve under 120°C.

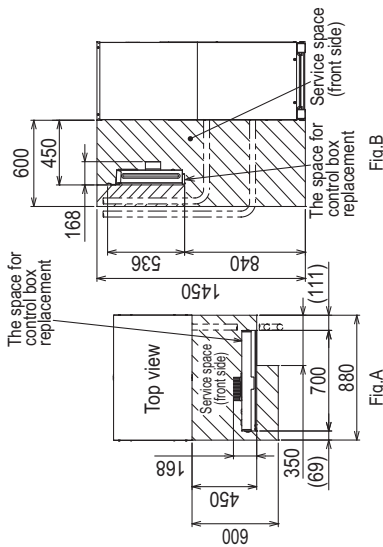

Connecting pipe specifications

Model	Refrigerant pipe		Service valve	
	Liquid	Gas	Liquid	Gas
PQHY-P350YLM-A1	ø12.7 Brazed *1 *2			
PQHY-P400YLM-A1	ø28.58 Brazed *1		ø15.88	ø28.58
PQHY-P450YLM-A1	ø15.88 Brazed *1			
PQHY-P500YLM-A1				

*1. Connect by using the connecting pipes and elbow that are supplied.
 *2. Use the pipe joint(field supply) and connect to the refrigerant service valve piping.

PQHY-P400,450,500,550,600YSLM-A1

Unit: mm

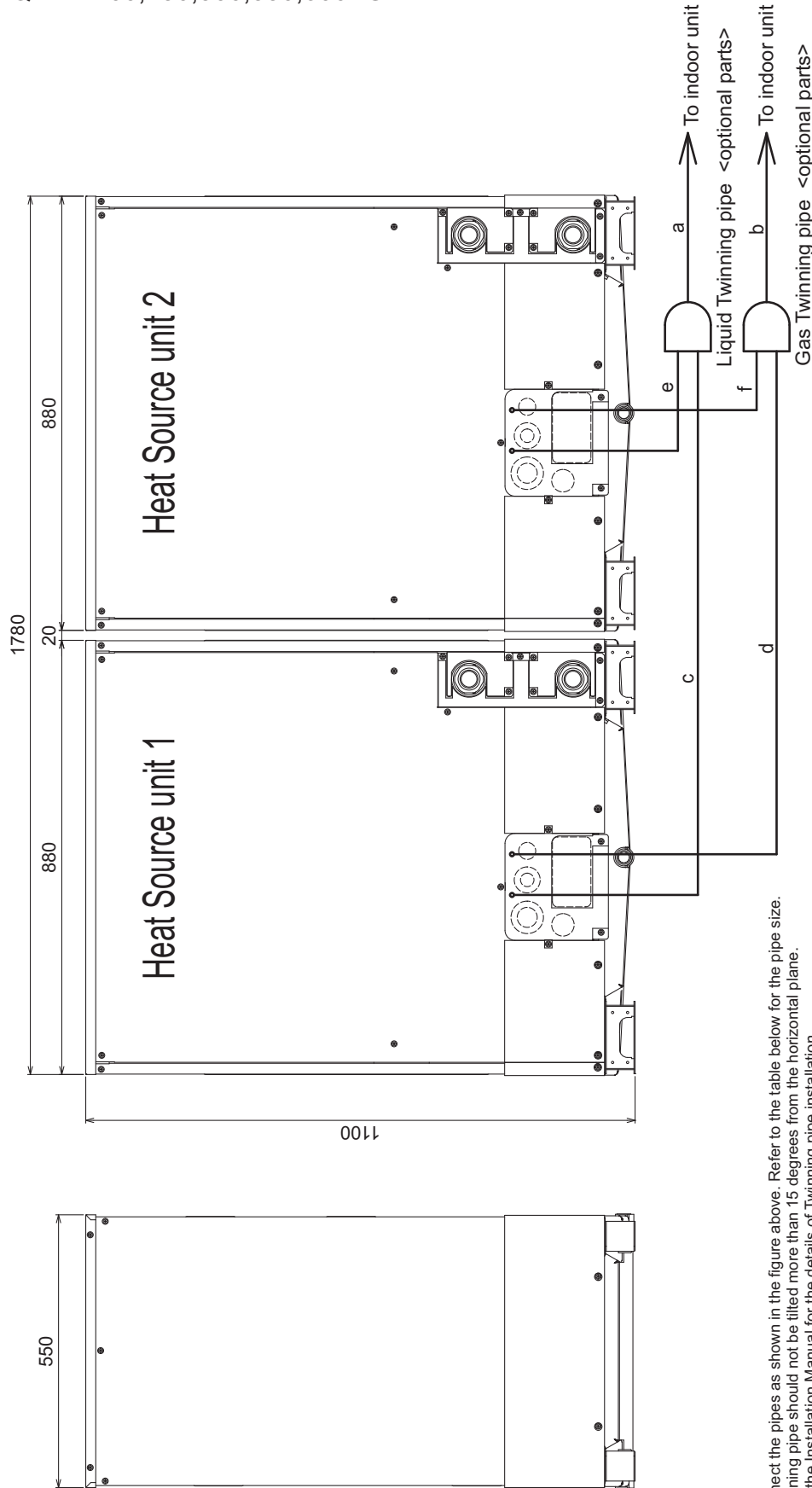

- Note 1. Connect the pipes as shown in the figure above. Refer to the table below for the pipe size.
 2. Twinning pipe should not be tilted more than 15 degrees from the horizontal plane.
 3. See the Installation Manual for the details of Twinning pipe installation.
 4. The pipe section before the Twinning pipe (sections "a" and "b" in the figure) must have at least 500mm of straight section (*including the straight pipe that is supplied with the Twinning pipe).
 5. Only use the Twinning pipe by Mitsubishi (optional parts).

Twinning pipe connection size

Package unit name	PQHY-P400YSLM-A1	PQHY-P450YSLM-A1	PQHY-P500YSLM-A1	PQHY-P550YSLM-A1	PQHY-P600YSLM-A1
Heat Source unit 1	PQHY-P200YLM-A1	PQHY-P250YLM-A1	PQHY-P250YLM-A1	PQHY-P300YLM-A1	PQHY-P300YLM-A1
Heat Source unit 2	PQHY-P200YLM-A1	PQHY-P200YLM-A1	PQHY-P250YLM-A1	PQHY-P250YLM-A1	PQHY-P300YLM-A1
Twinning pipe Kit(optional parts)	CMY-Y100VBK3				
Indoor unit-Twinning pipe	Liquid a	ø15.88			
	Gas b	ø28.58			
Twinning pipe-Heat Source unit 1	Liquid c	ø9.52		ø12.7	
	Gas d	ø19.05		ø22.2	
Twinning pipe-Heat Source unit 2	Liquid e	ø9.52		ø12.7	
	Gas f	ø19.05		ø22.2	

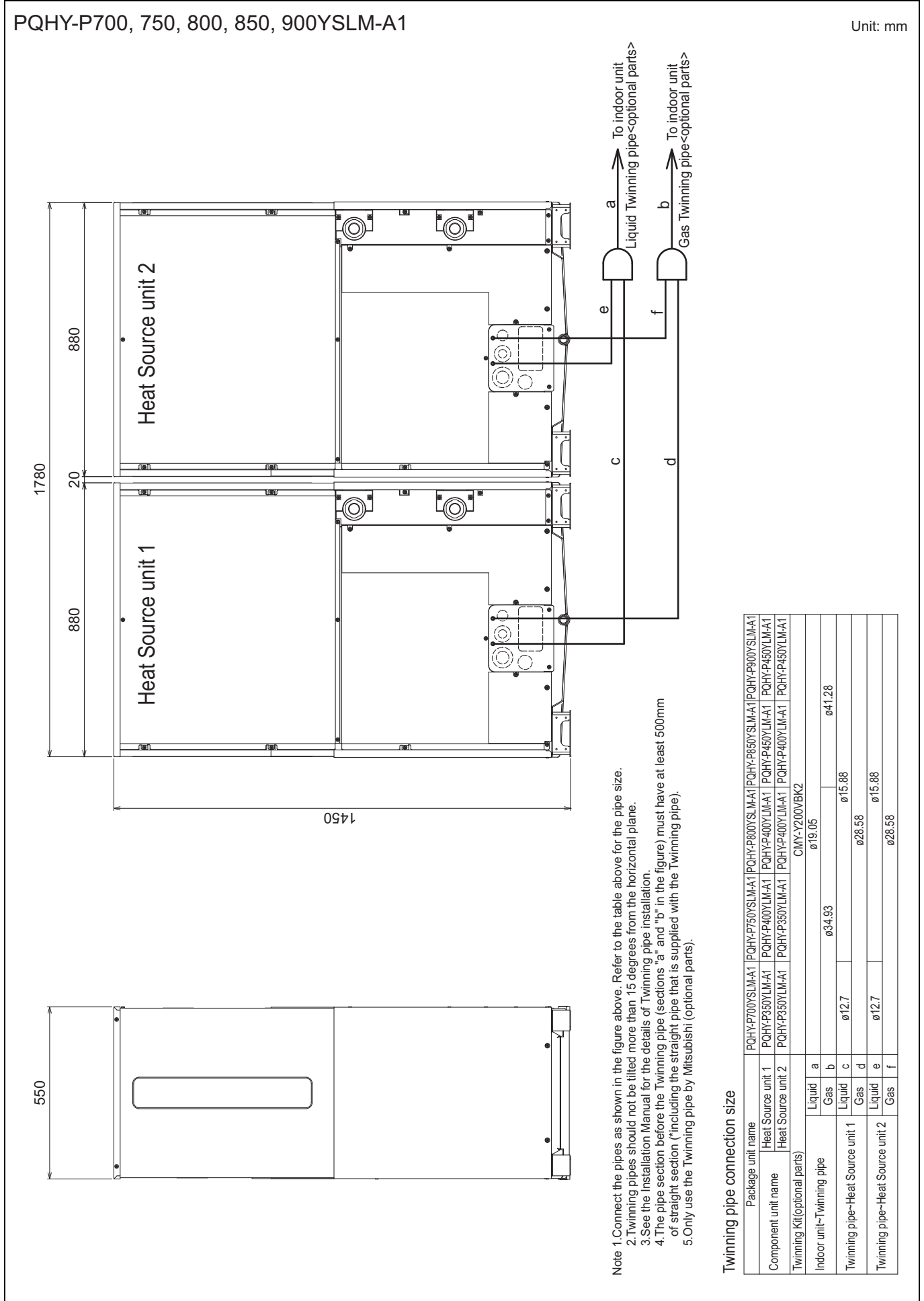

PQHY-P-Y(S)LM-A1

PQHY-P200, 250, 300YLM-A1

Unit: mm [in.]

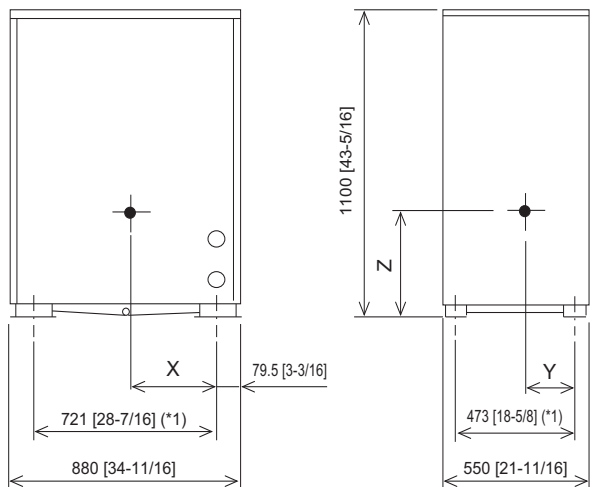

Model	X	Y	Z
PQHY-P200YLM-A1	359[14-3/16]	236[9-5/16]	437[17-1/4]
PQHY-P250YLM-A1	359[14-3/16]	236[9-5/16]	437[17-1/4]
PQHY-P300YLM-A1	359[14-3/16]	236[9-5/16]	437[17-1/4]

*1 Mounting Pitch

PQHY-P350, 400, 450, 500, 550, 600YLM-A1

Unit: mm [in.]

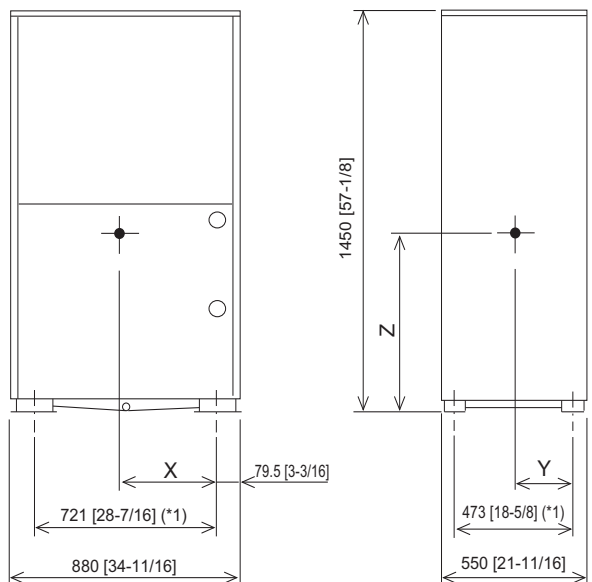

Model	X	Y	Z
PQHY-P350YLM-A1	373[14-11/16]	237[9-3/8]	630[24-13/16]
PQHY-P400YLM-A1	373[14-11/16]	237[9-3/8]	630[24-13/16]
PQHY-P450YLM-A1	373[14-11/16]	237[9-3/8]	630[24-13/16]
PQHY-P500YLM-A1	373[14-11/16]	237[9-3/8]	630[24-13/16]
PQHY-P550YLM-A1	346[13-5/8]	229[9-1/16]	655[25-13/16]
PQHY-P600YLM-A1	346[13-5/8]	229[9-1/16]	655[25-13/16]

*1 Mounting Pitch