

AIR CONDITIONING SYSTEMS

# CITY MULTI



## DATA BOOK

MODEL

**PMFY-P-VBM-E**

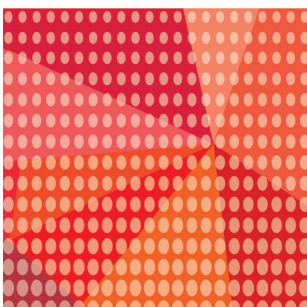

## PMFY-P-VBM-E

1. SPECIFICATIONS .....	2
2. EXTERNAL DIMENSIONS .....	3
3. CENTER OF GRAVITY .....	4
4. ELECTRICAL WIRING DIAGRAMS .....	5
5. SOUND LEVELS .....	6
5-1. Sound levels .....	6
5-2. NC curves .....	6
6. TEMPERATURE/AIRFLOW DISTRIBUTIONS.....	7
6-1. Temperature distributions .....	7
6-2. Airflow distributions .....	7
7. ELECTRICAL CHARACTERISTICS .....	8

# 1. SPECIFICATIONS

Ceiling cassette (1-way flow type)

PMFY-P-VBM-E

Model			PMFY-P20VBM-E	PMFY-P25VBM-E	PMFY-P32VBM-E	PMFY-P40VBM-E	
Power source			1-phase 220-240V 50Hz, 1-phase 220V 60Hz				
Cooling capacity (Nominal)	*1	kW	2.2	2.8	3.6	4.5	
	*1	BTU / h	7,500	9,600	12,300	15,400	
	*3	Power input	kW	0.042	0.044	0.044	0.054
	*3	Current input	A	0.20	0.21	0.21	0.26
Heating capacity (Nominal )	*2	kW	2.5	3.2	4.0	5.0	
	*2	BTU / h	8,500	10,900	13,600	17,100	
	*3	Power input	kW	0.042	0.044	0.044	0.054
	*3	Current input	A	0.20	0.21	0.21	0.26
External finish			Galvanized, with grey insulation sheet				
External dimension H x W x D		mm	230 x 812 x 395				
		in.	9-1/16 x 32 x 15-9/16				
Net weight		kg (lbs)	14 (31)				
Decoration panel	Model		PMP-40BMW	PMP-40BMW	PMP-40BMW	PMP-40BMW	
	External finish		MUNSELL (0.98Y 8.99/0.63)				
	Dimension		mm				
	H x W x D		30 x 1,000 x 470				
	Net Weight		in.				
		1-3/16 x 39-3/8 x 18-9/16					
		kg (lbs)					
		3 (7)					
Heat exchanger			Cross fin (Aluminum fin and copper tube)				
FAN	Type x Quantity		Line flow fan x 1				
	External static press.	Pa	0				
		mmH <sub>2</sub> O	0				
	Motor type		1-phase induction motor				
	Motor output		kW				
			0.028				
	Driving mechanism		Direct-driven by motor				
Airflow rate (Low-Mid2-Mid1-High)	m <sup>3</sup> / min		6.5 - 7.2 - 8.0 - 8.7	7.3 - 8.0 - 8.6 - 9.3	7.3 - 8.0 - 8.6 - 9.3	7.7 - 8.7 - 9.7 - 10.7	
	L / s		108 - 120 - 133 - 145	122 - 133 - 143 - 155	122 - 133 - 143 - 155	128 - 145 - 162 - 178	
	cfm		230 - 254 - 283 - 307	258 - 283 - 304 - 328	258 - 283 - 304 - 328	272 - 307 - 343 - 378	
Sound pressure level (Low-Mid2-Mid1-High) (measured in anechoic room)		dB <A>	27 - 30 - 33 - 35	32 - 34 - 36 - 37	32 - 34 - 36 - 37	33 - 35 - 37 - 39	
Insulation material			Polyester sheet				
Air filter			PP honeycomb fabric				
Protection device			Fuse				
Refrigerant control device			LEV				
Connectable outdoor unit			R410A CITY MULTI				
Diameter of refrigerant pipe	Liquid (R410A)	mm (in.)	ø6.35 (ø1/4) Flare	ø6.35 (ø1/4) Flare	ø6.35 (ø1/4) Flare	ø6.35 (ø1/4) Flare	
	Gas (R410A)	mm (in.)	ø12.7 (ø1/2) Flare	ø12.7 (ø1/2) Flare	ø12.7 (ø1/2) Flare	ø12.7 (ø1/2) Flare	
Field drain pipe size		mm (in.)	O.D. 26 (1)				
Drawing	External		IU-BH01-C184				
	Wiring		IU-RG79-A671				
	Refrigerant cycle						
Standard attachment	Document		Installation Manual, Instruction Book				
	Accessory		Drain hose I.D. 26 (1) (flexible joint)				
Remark	Optional parts						
	Decoration panel		PMP-40BMW	PMP-40BMW	PMP-40BMW	PMP-40BMW	
			*PMFY-P-VBM-E should used together with PMP-40BMW				
Installation		Details on foundation work, duct work, insulation work, electrical wiring, power source switch, and other items shall be referred to the Installation Manual.					
<b>Note :</b>			*1 Nominal cooling conditions			*2 Nominal heating conditions	
Indoor :			27°CDB/19°CWB (81°FDB/66°FWB)		20°CDB (68°FDB)	Unit converter	
Outdoor :			35°CDB (95°FDB)		7°CDB/6°CWB (45°FDB/43°FWB)	BTU/h = kW x 3,412	
Pipe length :			7.5 m (24-9/16 ft)		7.5 m (24-9/16 ft)	cfm = m <sup>3</sup> /min x 35.31	
Level difference :			0 m (0 ft)		0 m (0 ft)	lbs = kg / 0.4536	
* Nominal conditions *1, *2 are subject to JIS B8615-1.						*Above specification data is subject to rounding variation.	
* Due to continuing improvement, above specification may be subject to change without notice.							
*3 The values are measured at the rated external static pressure.							

Unit : mm

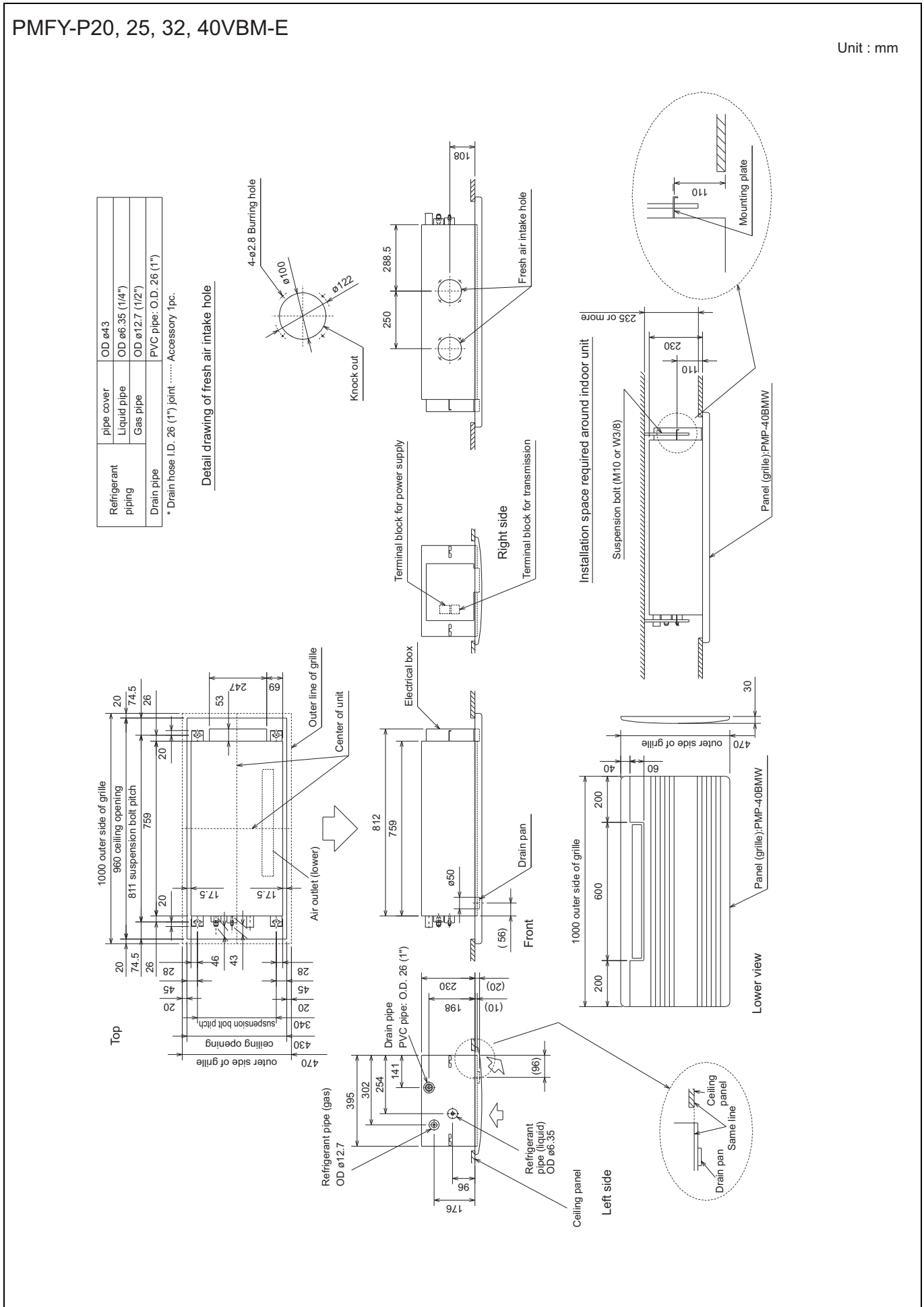

PMFY-P20, 25, 32, 40VBM-E

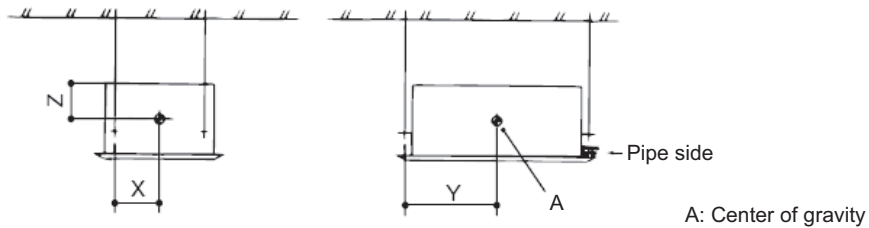

A: Center of gravity

(mm)[in]

Model name	X	Y	Z
PMFY-P20VBM-E	165 [6-1/2]	390 [15-3/8]	130 [5-1/8]
PMFY-P25VBM-E	165 [6-1/2]	390 [15-3/8]	130 [5-1/8]
PMFY-P32VBM-E	165 [6-1/2]	390 [15-3/8]	130 [5-1/8]
PMFY-P40VBM-E	165 [6-1/2]	390 [15-3/8]	130 [5-1/8]

PMFY-P20, 25, 32, 40VBM-E

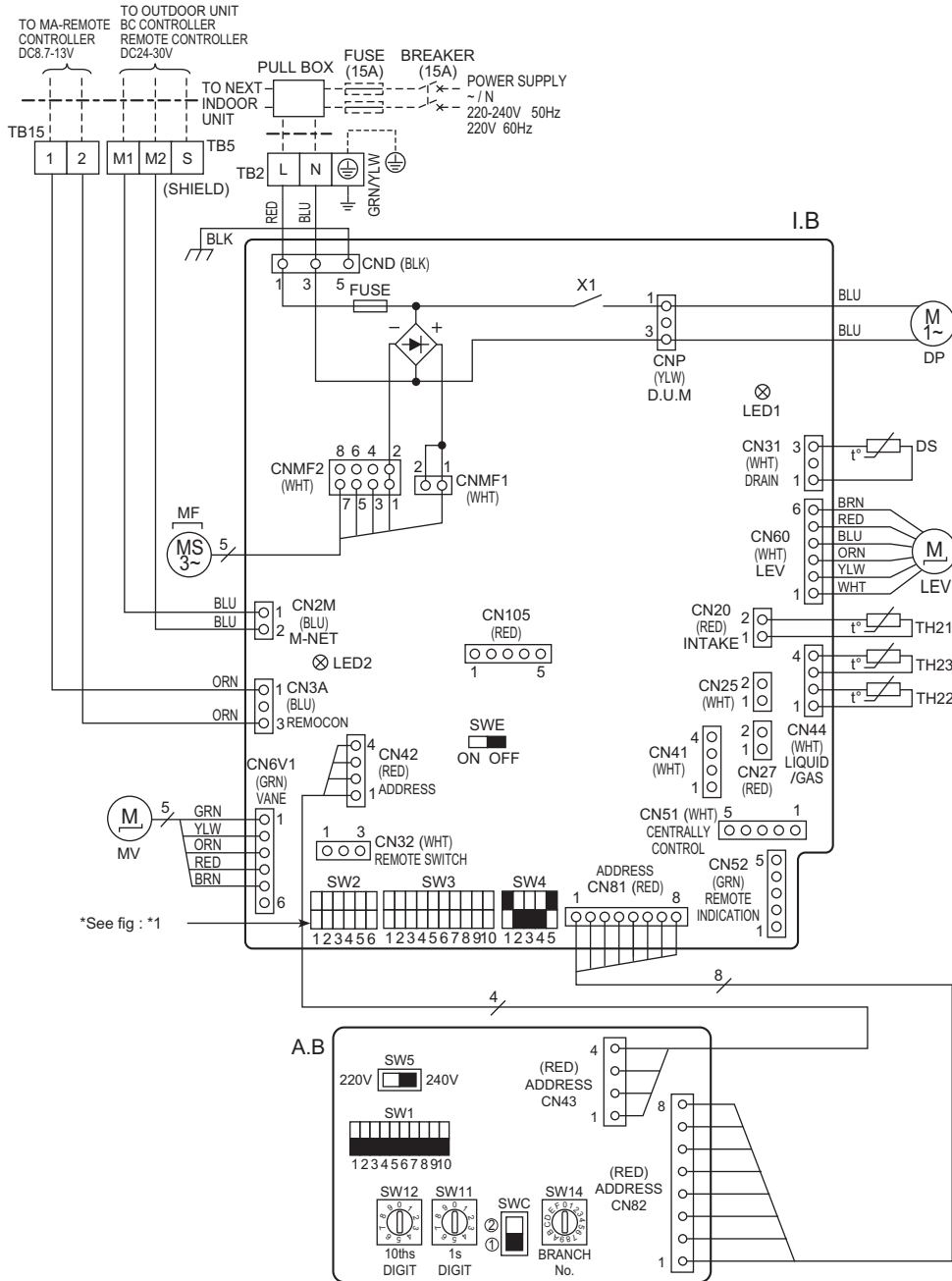

\*See fig : \*1

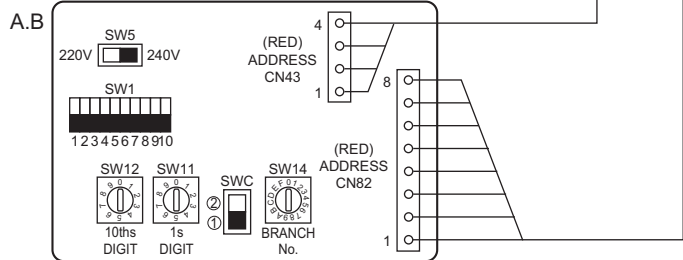

[LEGEND]

SYMBOL	NAME	SYMBOL	NAME
I.B	INDOOR CONTROLLER BOARD	DS	DRAIN SENSOR
CN25	CONNECTOR	TB2	TERMINAL BLOCK
CN27		TB5	
CN32		TB15	
CN51		TH21	
CN52		TH22	
CN105		TH23	
SW2	SWITCH	LEV	LINEAR EXPANSION VALVE
SW3		A.B	CIRCUIT BOARD
SW4		SW1	SWITCH
SWE		SW5	
FUSE	FUSE (T6.3AL 250V)	SW11	
X1	AUX.RELAY	SW12	
LED1	POWER SUPPLY (I.B)	SW14	
LED2	POWER SUPPLY (I.B)		
MF	FAN MOTOR		
MV	VANE MOTOR		
DP	DRAIN PUMP		

The black square (■) indicates a switch position. < \*1 >

MODELS	SW2	SW3
P20VBM	ON OFF [■] [ ] 123456	ON OFF [■] [ ] 12345678910
P25VBM	ON OFF [■] [ ] 123456	ON OFF [■] [ ] 12345678910
P32VBM	ON OFF [■] [ ] 123456	ON OFF [■] [ ] 12345678910
P40VBM	ON OFF [■] [ ] 123456	ON OFF [■] [ ] 12345678910

NOTES:

- At servicing for outdoor unit, always follow the wiring diagram of outdoor unit.
- In case of using MA-Remote controller, please connect to TB15. (Remote controller wire is non-polar.)
- In case of using M-NET, please connect to TB5. (Transmission line is non-polar.)
- Symbol [S] of TB5 is the shield wire connection.
- Symbols used in wiring diagram above are, [ ] : terminal block, [ ] : connector.
- The setting of the SW2 dip switches differs in the capacity. For the detail, refer to the table above.
- Please set the switch SW5 according to the power supply voltage. Set SW5 to 240V side when the power supply is 230 and 240 volts. When the power supply is 220 volts, set SW5 to 220V side.

LED on indoor board for service

Mark	Meaning	Function
LED1	Main power supply	Main power supply (Indoor unit:220-240V) Power on → lamp is lit
LED2	Power supply for MA-Remote controller	Power supply for MA-Remote controller on → lamp is lit

5-1. Sound levels

PMFY-P-VBM-E

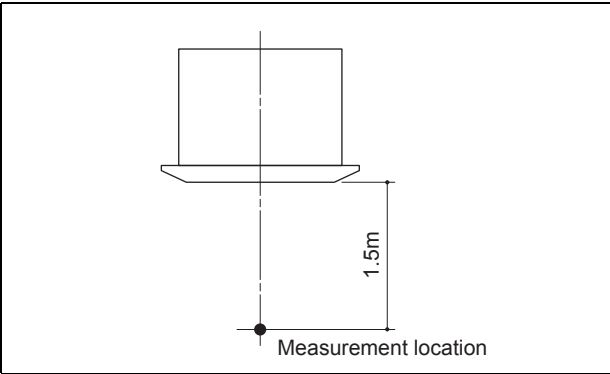

Sound level at anechoic room : Low-Middle2-Middle1-High

	Sound level dB (A)
PMFY-P20VBM-E	27-30-33-35
PMFY-P25VBM-E	32-34-36-37
PMFY-P32VBM-E	
PMFY-P40VBM-E	33-35-37-39

\* Measured in anechoic room

5-2. NC curves

PMFY-P20VBM-E

External static pressure : 0Pa  
Power source : 220, 230, 240V, 50Hz / 220V, 60Hz

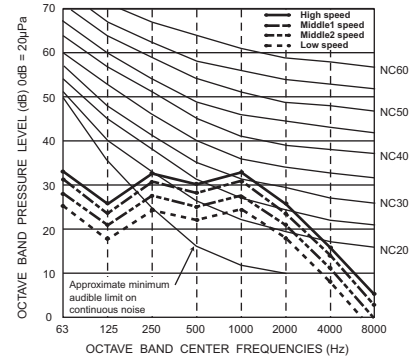

PMFY-P25, 32VBM-E

External static pressure : 0Pa  
Power source : 220, 230, 240V, 50Hz / 220V, 60Hz

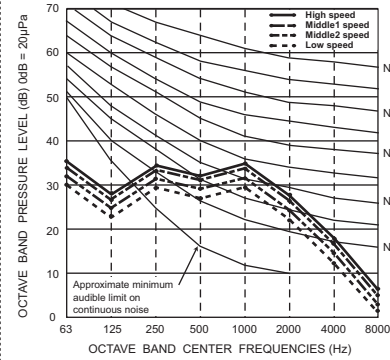

PMFY-P40VBM-E

External static pressure : 0Pa  
Power source : 220, 230, 240V, 50Hz / 220V, 60Hz

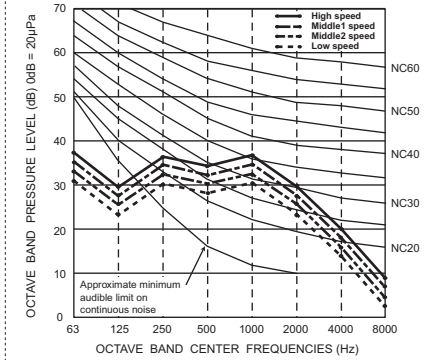

6-1. Temperature distributions

PMFY-P20-40VBM-E

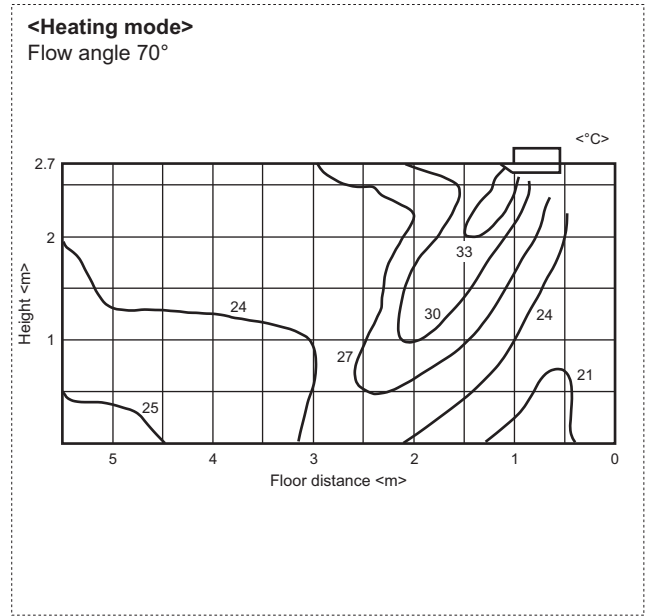
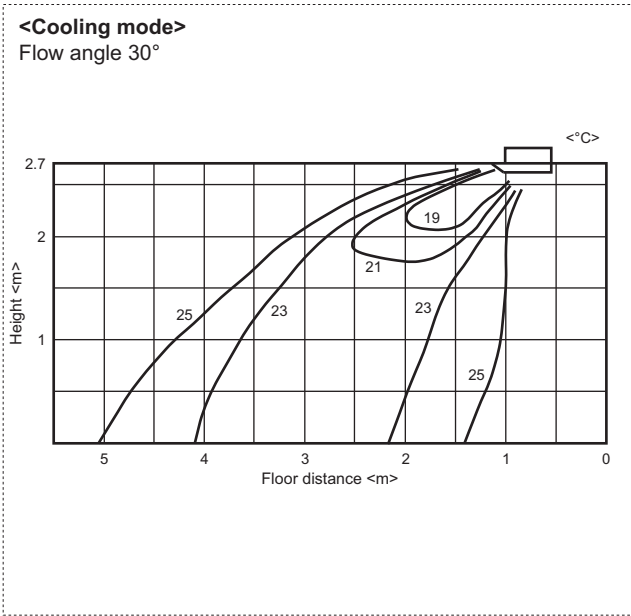

Note : These figures show typical temperature distributions in the conditions above. In the actual installation, they may differ from these figures under the influence of air temperature conditions, ceiling height, cooling/heating load, obstacles, etc.

6-2. Airflow distributions

PMFY-P20-40VBM-EC

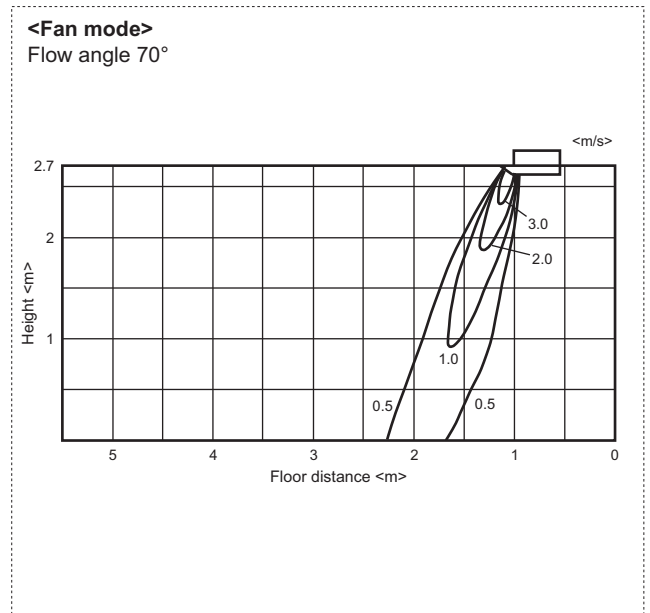
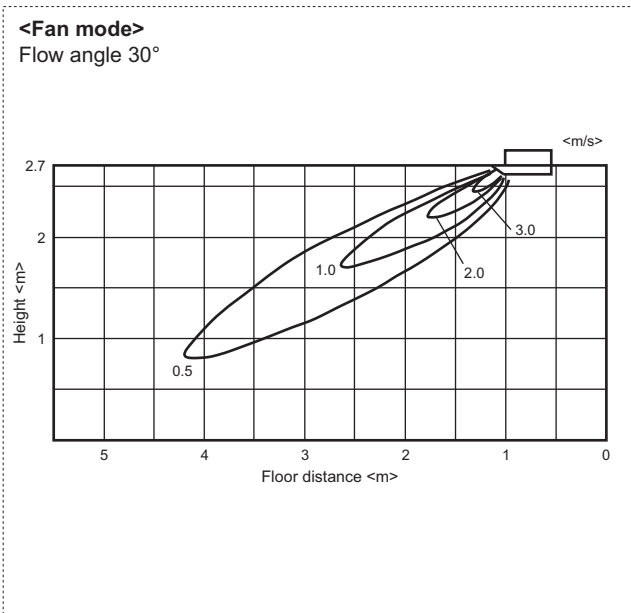

Note : These figures show typical airflow distributions in the conditions above. In the actual installation, they may differ from these figures under the influence of air temperature conditions, ceiling height, cooling/heating load, obstacles, etc.



## 7. ELECTRICAL CHARACTERISTICS

Ceiling cassette (1-way flow type)

Symbols: MCA (Max.Circuit Amps =1.25xFLA), FLA (Full Load Amps)  
IFM (Indoor Fan Motor), Output (Fan motor rated output)

PMFY-P-VBM-E	Power supply			IFM	
	Volts/Hz	Range +-10%	MCA(A)	Output (kW)	FLA(A)
PMFY-P20VBM-E	220-240V/50Hz 220V/60Hz	Max.: 264V Min.: 198V	0.25	0.028	0.20
PMFY-P25VBM-E			0.26	0.028	0.21
PMFY-P32VBM-E			0.26	0.028	0.21
PMFY-P40VBM-E			0.33	0.028	0.26

PMFY-P-VBM-E

**⚠ Warning**

- Do not use refrigerant other than the type indicated in the manuals provided with the unit and on the nameplate.
  - Doing so may cause the unit or pipes to burst, or result in explosion or fire during use, repair, or at the time of disposal of the unit.
  - It may also be in violation of applicable laws.
  - MITSUBISHI ELECTRIC CORPORATION cannot be held responsible for malfunctions or accidents resulting from the use of the wrong type of refrigerant.
- Our air conditioning equipment and heat pumps contain a fluorinated greenhouse gas, R410A.

**MITSUBISHI ELECTRIC CORPORATION**

[www.MitsubishiElectric.com](http://www.MitsubishiElectric.com)