

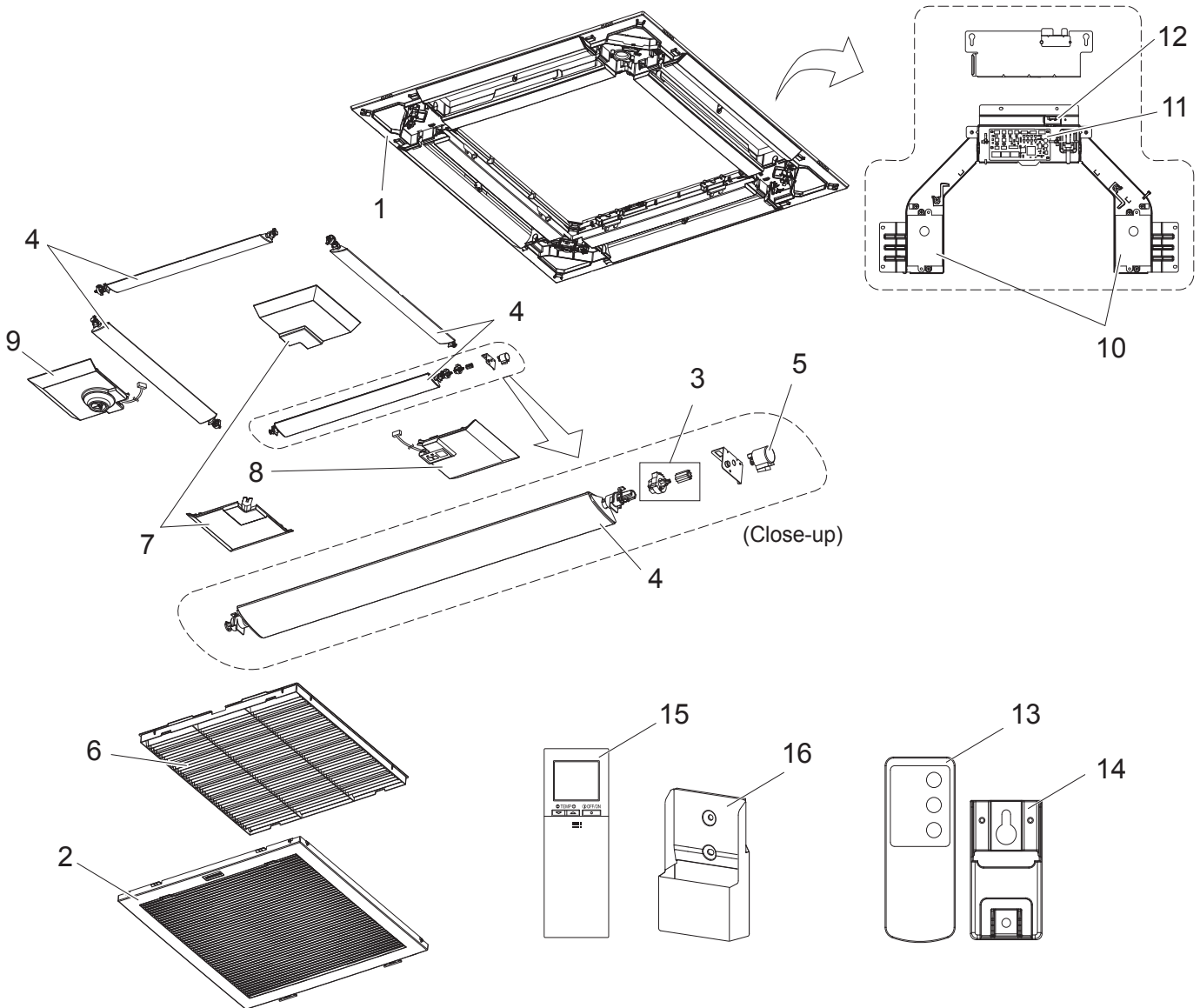

**GRILLE PARTS**

[Service Ref.]

PLP-6EA	PLP-6EAR1	(Standard)
PLP-6EAL	PLP-6EALR1	(Standard with signal receiver)
PLP-6EAE	PLP-6EAER1	(Standard with i-see Sensor)
PLP-6EALE	PLP-6EALER1	(Standard with signal receiver and i-see Sensor)
PLP-6EAJ		(Elevation)
PLP-6EAJE		(Elevation with i-see Sensor)
PLP-6EALM		(Standard with signal receiver and wireless remote controller)
PLP-6EALME		(Standard with signal receiver, i-see Sensor, and wireless remote controller)



1. The part quantity below indicates the required number of pieces per unit.
2. The circled No. indicates that the part is not shown in the figure.

No.	Parts No.	Parts Name	PLP-6EA	PLP-6EAR1	PLP-6EAL	PLP-6EALR1	PLP-6EAE	PLP-6EAER1	PLP-6EALE	PLP-6EALER1	PLP-6EAJ	PLP-6EAJE	PLP-6EALM	PLP-6EALME	Wiring Diagram Symbol	Remarks
1	E27 D72 003	AIR OUTLET GRILLE	1		1		1		1							
1	E27 F85 003	AIR OUTLET GRILLE		1		1		1		1	1	1	1			
2	E27 D72 010	INTAKE GRILLE	1		1		1		1							
2	E27 F85 010	INTAKE GRILLE		1		1		1		1			1	1		
2	E27 F91 010	INTAKE GRILLE									1	1				
3	E27 D72 031	GEAR (VANE & S/M)	4		4		4		4							
3	E27 F85 031	GEAR (VANE & S/M)		4		4		4		4	4	4	4	4		
4	E27 D72 037	AUTO VANE & VANE BUSH	4		4		4		4							1PC/SET
4	E27 F85 037	AUTO VANE & VANE BUSH		4		4		4		4	4	4	4	4		1PC/SET
5	E27 103 303	VANE MOTOR	4	4	4	4	4	4	4	4	4	4	4	4	MV	1PC/SET
6	E27 D72 100	AIR FILTER	1		1		1		1							
6	E27 F85 100	AIR FILTER		1		1		1		1	1	1	1	1		
7	E27 D72 975	CORNER PANEL	4		3		3		2							
7	E27 F85 975	CORNER PANEL		4		3		3		2	3	2	3	2		1PC/SET
8	E27 D73 975	CORNER PANEL (Signal receiver)			1				1							
8	E27 F88 975	CORNER PANEL (Signal receiver)				1				1	1	1	1	1		
9	E27 D74 975	CORNER PANEL (i-see Sensor)					1		1							
9	E27 F86 975	CORNER PANEL (i-see Sensor)						1		1		1		1		
10	E27 F91 471	MOTOR BOX									2	2				2PCS/SET
11	E27 F91 447	INDOOR CONTROLLER BOARD									1	1				
12	E27 F91 316	LIMIT SWITCH									1	1				
13	E27 F91 426	REMOTE CONTROLLER INFRARED									1	1				for Elevation panel
14	E27 F91 083	REMOTE CONTROLLER HOLDER									1	1				for Elevation panel
15	E27 58G 426	REMOTE CONTROLLER INFRARED											1	1		PAR-SL101A-E
16	E27 D44 083	REMOTE CONTROLLER HOLDER											1	1		for PAR-SL101A-E

**PLP-6EAB**

**(Black panel)**

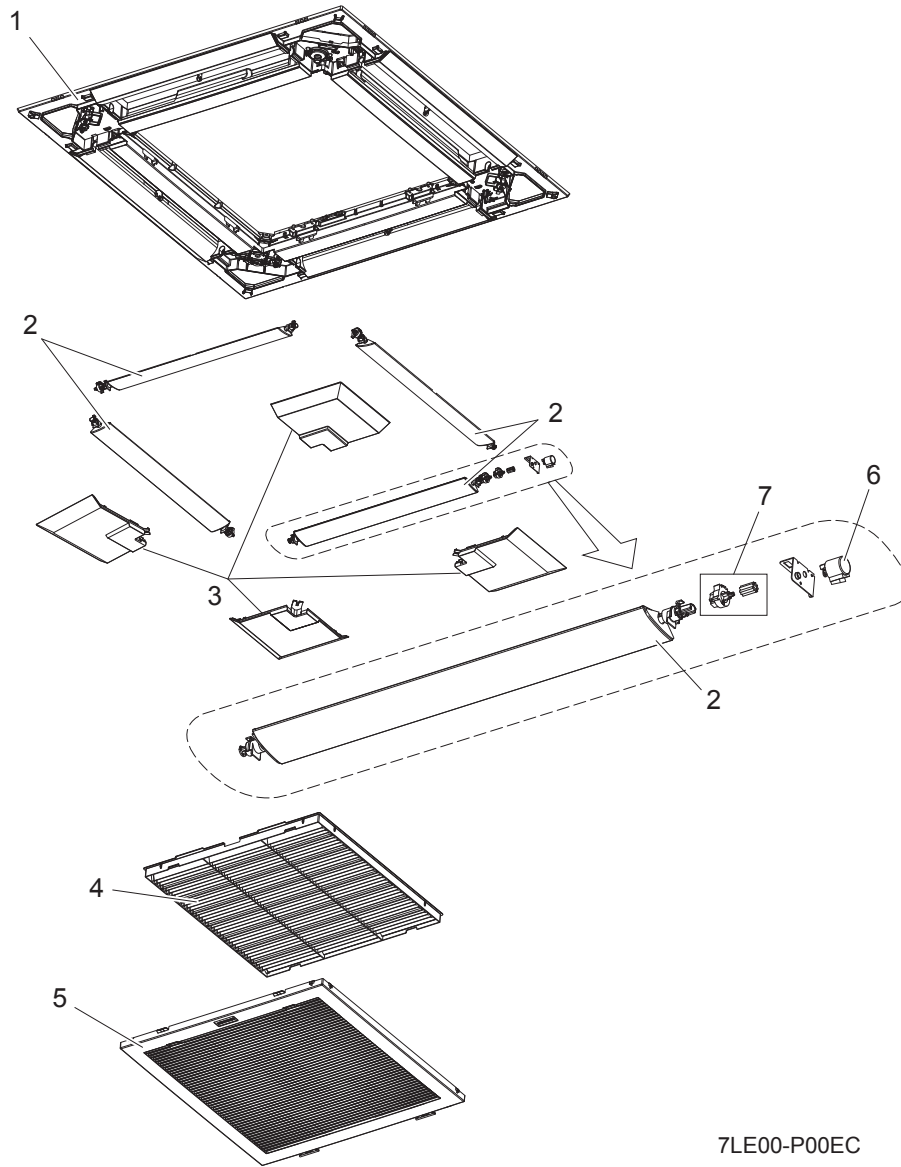

7LE00-P00EC

- 1. The part quantity below indicates the required number of pieces per unit.
- 2. The circled No. indicates that the part is not shown in the figure.

No.	Parts No.	Parts Name	PLP-6EAB	Wiring Diagram Symbol	Remarks
1	T7W E24 003	PANEL ASSY	1		
2	T7W E15 002	VANE & BUSH ASSY	4		
3	T7W E14 638	CORNER PANEL	4		
4	T7W E05 500	L.L FILTER	1		
5	T7W E27 691	INTAKE GRILLE	1		
6	R01 E19 223	STEPPING MOTOR	4	MV	
7	R01 E06 040	GEARS SET	4		

## STRUCTURAL AND FUNCTIONAL PARTS

PLFY-WL20VEM-E.UK  
 PLY-WL25VEM-E.UK  
 PLY-WL32VEM-E.UK  
 PLY-WL32VEM-ET.UK  
 PLY-WL40VEM-E.UK  
 PLY-WL40VEM-ET.UK  
 PLY-WL50VEM-E.UK  
 PLY-WL50VEM-ET.UK  
 PLY-WL63VEM-E.UK  
 PLY-WL80VEM-E.UK  
 PLY-WL100VEM-E.UK  
 PLY-WL125VEM-E.UK

PLFY-WL20VEM-ET.UK  
 PLY-WL25VEM-ET.UK  
 PLY-WL32VEM-ER1.UK  
 PLY-WL32VEM-ETR1.UK  
 PLY-WL40VEM-ER1.UK  
 PLY-WL40VEM-ETR1.UK  
 PLY-WL50VEM-ER1.UK  
 PLY-WL50VEM-ETR1.UK  
 PLY-WL63VEM-ET.UK  
 PLY-WL80VEM-ET.UK  
 PLY-WL100VEM-ET.UK  
 PLY-WL125VEM-ET.UK

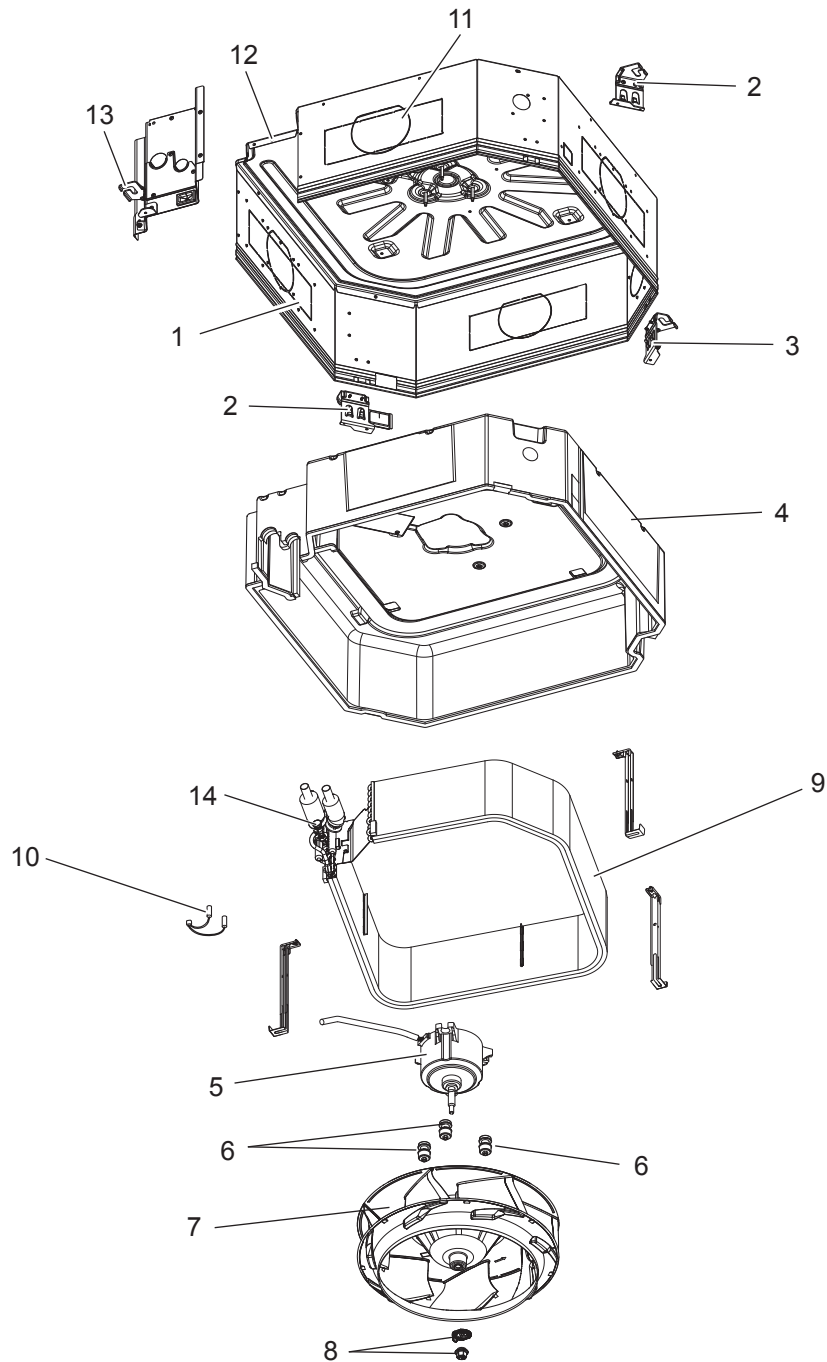

1. The part quantity below indicates the required number of pieces per unit.
2. The circled No. indicates that the part is not shown in the figure.

No.	Parts No.	Parts Name	PLFY-WL20VEM-E.UK	PLFY-WL20VEM-ET.UK	PLFY-WL25VEM-E.UK	PLFY-WL25VEM-ET.UK	PLFY-WL32VEM-E.UK	PLFY-WL32VEM-ER1.UK	PLFY-WL32VEM-ET.UK	PLFY-WL32VEM-ETR1.UK	PLFY-WL40VEM-E.UK	PLFY-WL40VEM-ER1.UK	PLFY-WL40VEM-ET.UK	PLFY-WL40VEM-ETR1.UK	PLFY-WL50VEM-E.UK	PLFY-WL50VEM-ER1.UK	PLFY-WL50VEM-ET.UK	PLFY-WL50VEM-ETR1.UK	Wiring Diagram Symbol	Remarks
			1	1	1	1	1	1	1	1	1	1	1	1	1	1	1	1		
1	S70 0B7 688	DRUM 2 ASSY	1	1	1	1	1	1	1	1	1	1	1	1	1	1	1	1		
2	S70 EA2 130	LEG PUMP	2	2	2	2	2	2	2	2	2	2	2	2	2	2	2	2		
3	S70 EA1 130	LEG FA	1	1	1	1	1	1	1	1	1	1	1	1	1	1	1	1		
4	S70 0B6 659	INNER COVER ASSY-S	1	1	1	1	1	1	1	1	1	1	1	1	1	1	1	1		
5	S70 0B4 762	FAN MOTOR	1	1	1	1	1	1	1	1	1	1	1	1	1	1	1	1	MF	(DC)-S
6	S70 0B1 105H	MOTOR MOUNT	3	3	3	3	3	3	3	3	3	3	3	3	3	3	3	3		
7	S70 0B4 114	TURBO FAN	1	1	1	1	1	1	1	1	1	1	1	1	1	1	1	1		
8	S70 11B 097	SPL WASHER/NUT	1	1	1	1	1	1	1	1	1	1	1	1	1	1	1	1		M8
9	S70 B31 480	HEAT EXCHANGER					1	1	1	1	1	1	1	1	1	1	1	1		
9	S70 B38 480	HEAT EXCHANGER	1	1	1	1														
10	S70 0B4 202	THERMISTOR	1	1	1	1	1	1	1	1	1	1	1	1	1	1	1	1	TH22/ TH23	
11	S70 0B5 688	DRUM 1 ASSY	1	1	1	1	1	1	1	1	1	1	1	1	1	1	1	1		
12	S70 0B2 687	BASE	1	1	1	1	1	1	1	1	1	1	1	1	1	1	1	1		
13	S70 EA3 130	LEG PIPE	1	1	1	1	1	1	1	1	1	1	1	1	1	1	1	1		
14	S70 W40 151	AIR PURGE VALVE	1	1	1	1	1	1	1	1	1	1	1	1	1	1	1	1		

No.	Parts No.	Parts Name	PLFY-WL63VEM-E.UK	PLFY-WL63VEM-ET.UK	PLFY-WL80VEM-E.UK	PLFY-WL80VEM-ET.UK	PLFY-WL100VEM-E.UK	PLFY-WL100VEM-ET.UK	PLFY-WL125VEM-E.UK	PLFY-WL125VEM-ET.UK	Wiring Diagram Symbol	Remarks
			1	1	1	1	1	1	1	1		
1	S70 0B8 688	DRUM 2 ASSY	1	1	1	1	1	1	1	1		
2	S70 EA2 130	LEG PUMP	2	2	2	2	2	2	2	2		
3	S70 EA1 130	LEG FA	1	1	1	1	1	1	1	1		
4	S70 0B7 659	INNER COVER ASSY-L	1	1	1	1	1	1	1	1		
5	S70 0B5 762	FAN MOTOR	1	1	1	1	1	1	1	1	MF	(DC)-L
6	S70 0B1 105H	MOTOR MOUNT	3	3	3	3	3	3	3	3		
7	S70 0B4 114	TURBO FAN	1	1	1	1	1	1	1	1		
8	S70 11B 097	SPL WASHER/NUT	1	1	1	1	1	1	1	1		M8
9	S70 B39 480	HEAT EXCHANGER	1	1	1	1						
9	S70 B40 480	HEAT EXCHANGER					1	1				
9	S70 B41 480	HEAT EXCHANGER							1	1		
10	S70 0B4 202	THERMISTOR	1	1	1	1	1	1	1	1	TH22/TH23	
11	S70 0B6 688	DRUM 1 ASSY	1	1	1	1	1	1	1	1		
12	S70 0B2 687	BASE	1	1	1	1	1	1	1	1		
13	S70 EA3 130	LEG PIPE	1	1	1	1	1	1	1	1		
14	S70 W40 151	AIR PURGE VALVE	1	1	1	1	1	1	1	1		

## FUNCTIONAL AND ELECTRICAL PARTS

PLFY-WL20VEM-E.UK  
 PLFY-WL25VEM-E.UK  
 PLFY-WL32VEM-E.UK  
 PLFY-WL32VEM-ET.UK  
 PLFY-WL40VEM-E.UK  
 PLFY-WL40VEM-ET.UK  
 PLFY-WL50VEM-E.UK  
 PLFY-WL50VEM-ET.UK  
 PLFY-WL63VEM-E.UK  
 PLFY-WL80VEM-E.UK  
 PLFY-WL100VEM-E.UK  
 PLFY-WL125VEM-E.UK

PLFY-WL20VEM-ET.UK  
 PLFY-WL25VEM-ET.UK  
 PLFY-WL32VEM-ER1.UK  
 PLFY-WL32VEM-ETR1.UK  
 PLFY-WL40VEM-ER1.UK  
 PLFY-WL40VEM-ETR1.UK  
 PLFY-WL50VEM-ER1.UK  
 PLFY-WL50VEM-ETR1.UK  
 PLFY-WL63VEM-ET.UK  
 PLFY-WL80VEM-ET.UK  
 PLFY-WL100VEM-ET.UK  
 PLFY-WL125VEM-ET.UK

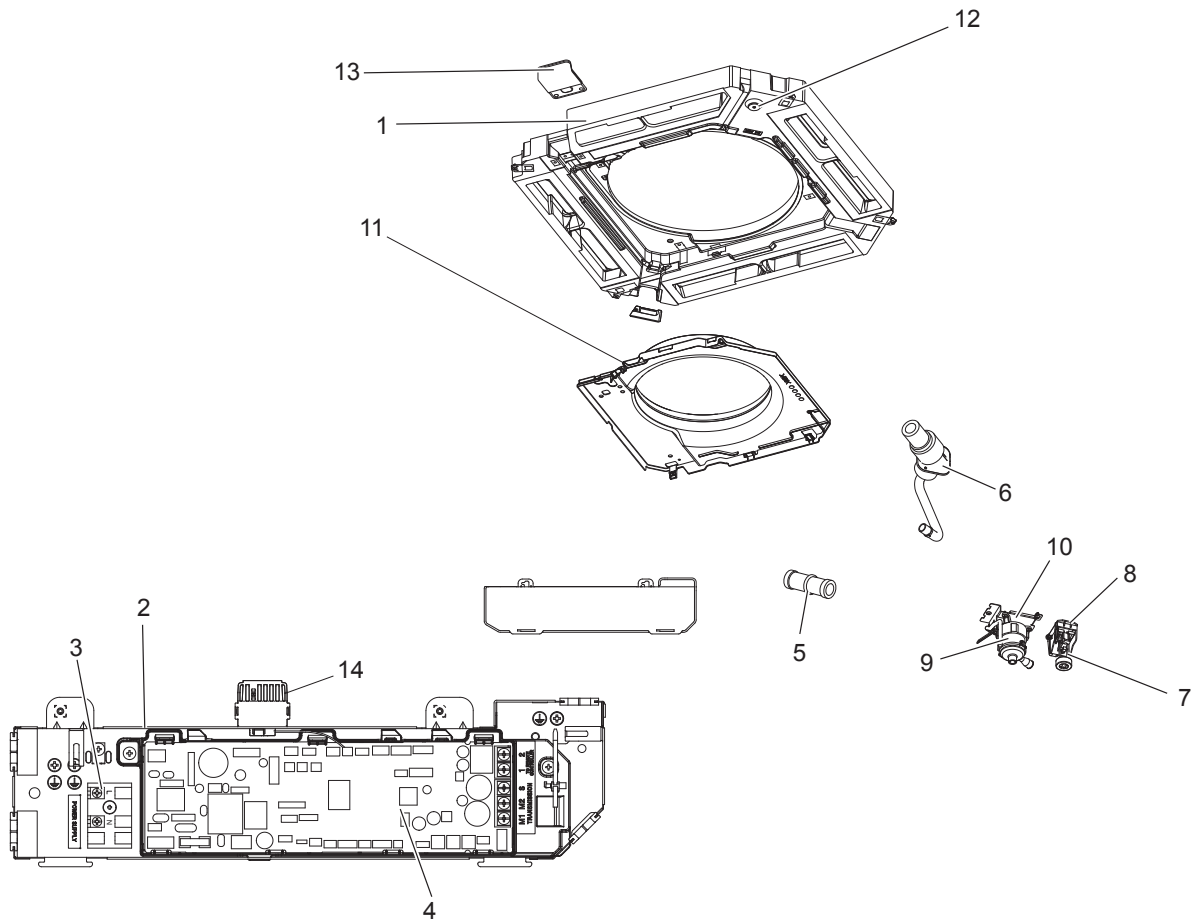

1. The part quantity below indicates the required number of pieces per unit.
2. The circled No. indicates that the part is not shown in the figure.

No.	Parts No.	Parts Name	PLFY-WL20VEM-E.UK	PLFY-WL20VEM-ET.UK	PLFY-WL25VEM-E.UK	PLFY-WL25VEM-ET.UK	PLFY-WL32VEM-E.UK	PLFY-WL32VEM-ER1.UK	PLFY-WL32VEM-ET.UK	PLFY-WL32VEM-ETR1.UK	PLFY-WL40VEM-E.UK	PLFY-WL40VEM-ER1.UK	PLFY-WL40VEM-ET.UK	PLFY-WL40VEM-ETR1.UK	PLFY-WL50VEM-E.UK	PLFY-WL50VEM-ER1.UK	PLFY-WL50VEM-ET.UK	PLFY-WL50VEM-ETR1.UK	Wiring Diagram Symbol	Remarks
1	S70 0B5 529H	DRAIN PAN	1	1	1	1	1	1	1	1	1	1	1	1	1	1	1	1		
2	S70 0B7 501	ELECTRICAL CONTROL BOX	1	1	1	1	1	1	1	1	1	1	1	1	1	1	1	1		
3	S70 B03 716	TERMINAL BLOCK	1	1	1	1	1	1	1	1	1	1	1	1	1	1	1	1	TB2	2P (L,N)
4	S70 B35 310	INDOOR CONTROLLER BOARD					1	1	1	1	1	1	1	1	1	1	1	1		
4	S70 B36 310	INDOOR CONTROLLER BOARD	1	1	1	1														
5	S70 29H 523	DRAIN SOCKET	1	1	1	1	1	1	1	1	1	1	1	1	1	1	1	1		
6	S70 0B2 527H	DRAIN HOSE ASSY	1	1	1	1	1	1	1	1	1	1	1	1	1	1	1	1		
7	S70 0B2 266	FLOAT SWITCH	1	1	1	1	1	1	1	1	1	1	1	1	1	1	1	1	FS	
8	S70 0B2 533	FLOAT SWITCH BASE	1	1	1	1	1	1	1	1	1	1	1	1	1	1	1	1		
9	S70 0B2 355	DRAIN PUMP	1	1	1	1	1	1	1	1	1	1	1	1	1	1	1	1	DP	220-240 V
10	S70 0B3 533	DRAIN PUMP BASE	1	1	1	1	1	1	1	1	1	1	1	1	1	1	1	1		
11	S70 0B3 502	BELLMOUTH-S	1	1	1	1	1	1	1	1	1	1	1	1	1	1	1	1		
12	S70 A41 524H	DRAIN PLUG	1	1	1	1	1	1	1	1	1	1	1	1	1	1	1	1		
13	S70 EA1 663	WIRE COVER-HI ASSY	1	1	1	1	1	1	1	1	1	1	1	1	1	1	1	1		
14	S70 0B3 202	ROOM TEMP. THERMISTOR	1	1	1	1	1	1	1	1	1	1	1	1	1	1	1	1	TH21	220XAP

No.	Parts No.	Parts Name	PLFY-WL63VEM-E.UK	PLFY-WL63VEM-ET.UK	PLFY-WL80VEM-E.UK	PLFY-WL80VEM-ET.UK	PLFY-WL100VEM-E.UK	PLFY-WL100VEM-ET.UK	PLFY-WL125VEM-E.UK	PLFY-WL125VEM-ET.UK	Wiring Diagram Symbol	Remarks
1	S70 0B5 529H	DRAIN PAN	1	1	1	1	1	1	1	1		
2	S70 0B7 501	ELECTRICAL CONTROL BOX	1	1	1	1	1	1	1	1		
3	S70 B03 716	TERMINAL BLOCK	1	1	1	1	1	1	1	1	TB2	2P (L,N)
4	S70 B36 310	INDOOR CONTROLLER BOARD	1	1	1	1	1	1	1	1		
5	S70 29H 523	DRAIN SOCKET	1	1	1	1	1	1	1	1		
6	S70 0B2 527H	DRAIN HOSE ASSY	1	1	1	1	1	1	1	1		
7	S70 0B2 266	FLOAT SWITCH	1	1	1	1	1	1	1	1	FS	
8	S70 0B2 533	FLOAT SWITCH BASE	1	1	1	1	1	1	1	1		
9	S70 0B2 355	DRAIN PUMP	1	1	1	1	1	1	1	1	DP	220-240 V
10	S70 0B3 533	DRAIN PUMP BASE	1	1	1	1	1	1	1	1		
11	S70 0B4 502	BELLMOUTH-L	1	1	1	1	1	1	1	1		
12	S70 A41 524H	DRAIN PLUG	1	1	1	1	1	1	1	1		
13	S70 EA1 663	WIRE COVER-HI ASSY	1	1	1	1	1	1	1	1		
14	S70 0B3 202	ROOM TEMP. THERMISTOR	1	1	1	1	1	1	1	1	TH21	220XAP



## 2

## OPTIONAL PARTS

Parts name	Parts No.	
SPACE PANEL	PAC-SJ65AS-E	
AIR OUTLET SHUTTER PLATE	PAC-SJ37SP-E	
WIRED REMOTE CONTROLLER (MA REMOTE CONTROLLER)	PAR-U02MEDA	
WIRED REMOTE CONTROLLER (SIMPLE MA REMOTE CONTROLLER)	PAC-YT52CRA	
WIRELESS REMOTE CONTROLLER	PAR-SL100A-E	
WIRELESS REMOTE CONTROLLER	PAR-FL32MA	
HIGH EFFICIENCY FILTER ELEMENT	PAC-SH59KF-E	
MULTI-FUNCTIONAL CASEMENT	PAC-SH53TM-E	
FLANGE FOR FRESH AIR INTAKE	PAC-SH65OF-E	
MA & CONTACT TERMINAL INTERFACE	MAC-397IF-E	
REMOTE SENSOR	PAC-SE41TS-E	
Wi-Fi INTERFACE	MAC-557IF-E	
REMOTE ON/OFF ADAPTER	PAC-SE55RA-E	
REMOTE DISPLAY ADAPTER	PAC-SA88HA-E	
GRILLE (i-see Sensor)	PLP-6EAE PLP-6EAER1	
GRILLE (i-see Sensor with signal receiver)	PLP-6EALE PLP-6EALER1	
GRILLE (i-see Sensor with receiver and wireless remote controller)	PLP-6EALME	
GRILLE (Standard)	PLP-6EA PLP-6EAR1	
GRILLE (Standard with signal receiver)	PLP-6EAL PLP-6EALR1	
GRILLE (Standard with receiver and wireless remote controller)	PLP-6EALM	
GRILLE (Automatic filter elevation without i-see Sensor)	PLP-6EAJ	
GRILLE (Automatic filter elevation with i-see Sensor)	PLP-6EAJE	
GRILLE (Black panel)	PLP-6EAB	
i-SEE SENSOR CORNER PANEL	PAC-SE1ME-E	
SIGNAL RECEIVER CORNER PANEL	PAR-SE9FA-E	
VALVE KIT	PAC-SK04VK-E	
	PAC-SK35VK-E	
	LEAD WIRE	PAC-SK40LW-E
	ATTACHMENT PLATE	PAC-SK39AP-E

# CITY MULTI

## MITSUBISHI ELECTRIC CORPORATION

HEAD OFFICE : TOKYO BUILDING, 2-7-3, MARUNOUCHI, CHIYODA-KU, TOKYO 100-8310, JAPAN

---