

PLFY-P15, 20, 25, 32, 40, 50VFM-E1

Unit: mm

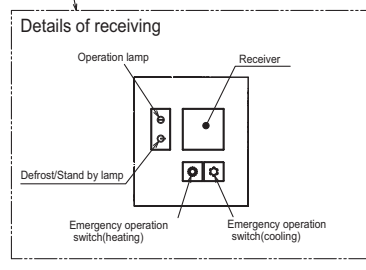
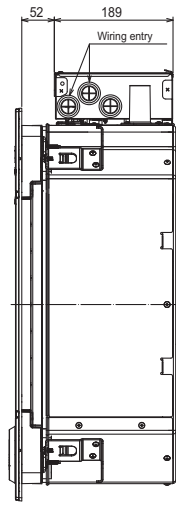
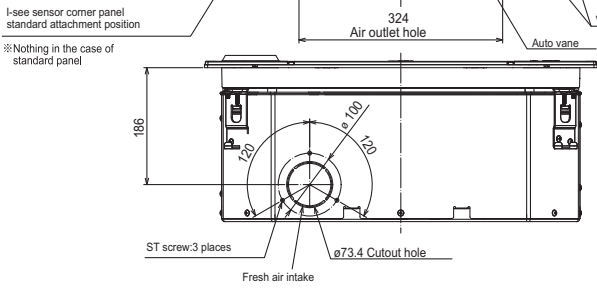
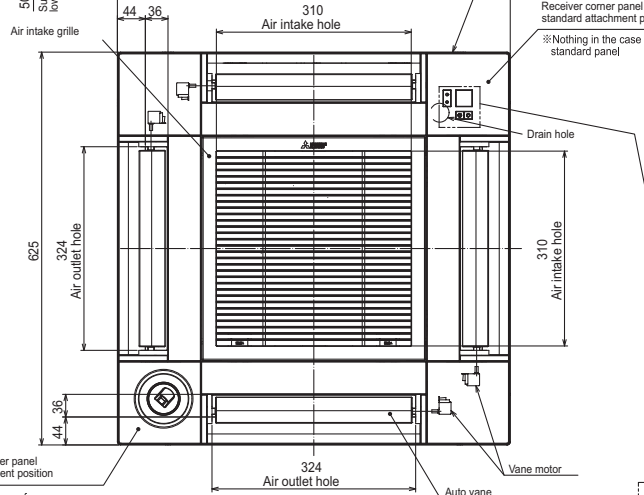
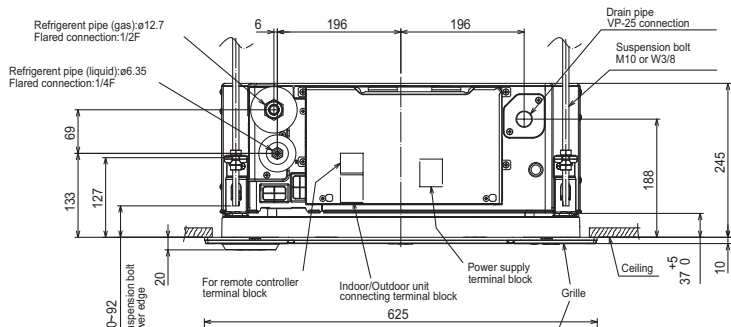
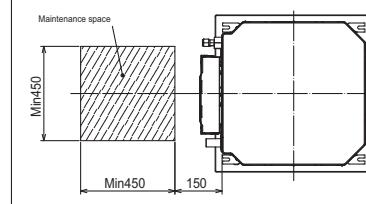
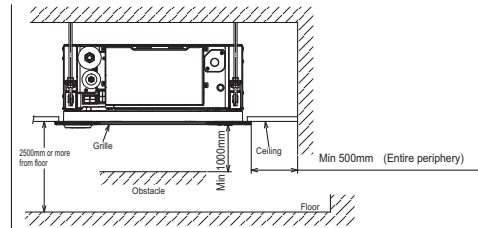
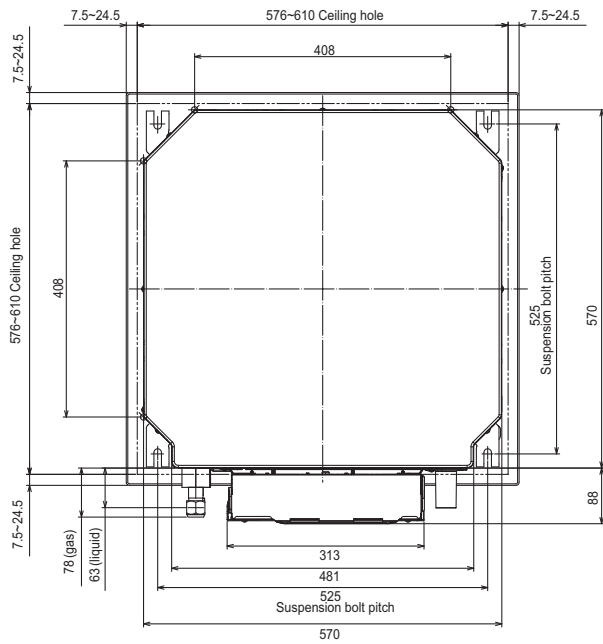

PLFY-P-VFM-E1