

AIR CONDITIONING SYSTEMS

CITY MULTI



DATA BOOK

MODEL

PLFY-M-VEM6-E

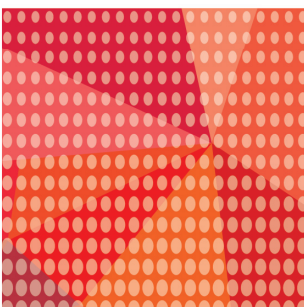

PLFY-M-VEM6-E

1. SPECIFICATIONS	2
2. EXTERNAL DIMENSIONS	5
3. CENTER OF GRAVITY	6
4. ELECTRICAL WIRING DIAGRAMS	7
5. SOUND LEVELS	8
5-1. Sound levels	8
5-2. NC curves	8
6. TEMPERATURE/AIRFLOW DISTRIBUTIONS.....	10
6-1. Temperature distributions	10
6-2. Airflow distributions	12
7. CAPACITY TABLES	14
7-1. Correction by fan speed.....	14
8. ELECTRICAL CHARACTERISTICS.....	15
9. OPTIONAL PARTS.....	16
9-1. Optional parts line up for the Indoor unit.....	16
9-2. Air outlet shutter plate.....	16
9-3. High efficiency filter element.....	17
9-4. Multi-function casement.....	17
9-5. 3D i-see Sensor corner panel	17
9-6. Auto elevation panel	18
9-7. Wireless signal receiver.....	19
9-8. Space panel.....	19
9-9. Duct flange for fresh air intake	19
9-10.V blocking filter	19
9-11.3D Total flow unit.....	20
9-12.Plasma Quad Connect	20

1. SPECIFICATIONS

Ceiling cassette (4-way flow type)

PLFY-M-VEM6-E

Model			PLFY-M20VEM6-E	PLFY-M25VEM6-E	PLFY-M32VEM6-E	PLFY-M40VEM6-E	
Power source			1-phase 220-240V 50Hz, 1-phase 220V 60Hz				
Cooling capacity (Nominal)	*1	kW	2.2	2.8	3.6	4.5	
		BTU / h	7,500	9,600	12,300	15,400	
	Power input	kW	0.03	0.03	0.03	0.03	
		Current input	A	0.31	0.31	0.32	0.32
Heating capacity (Nominal)	*2	kW	2.5	3.2	4.0	5.0	
		BTU / h	8,500	10,900	13,600	17,100	
	Power input	kW	0.03	0.03	0.03	0.03	
		Current input	A	0.24	0.24	0.25	0.25
External finish			Galvanized steel sheet				
External dimension H x W x D		mm	258 x 840 x 840				
		in.	10-3/16 x 33-3/32 x 33-3/32				
Net weight		kg (lbs)	19 (42)	19 (42)	19 (42)	19 (42)	
Decoration panel	Model		PLP-6EA	PLP-6EA	PLP-6EA	PLP-6EA	
	External finish		MUNSELL (1.0Y 9.2/0.2)				
	Dimension H x W x D	mm	40 x 950 x 950				
		in.	1-9/16 x 37-13/32 x 37-13/32				
	Net weight		kg (lbs)	5 (11)			
Heat exchanger			Cross fin (Aluminum fin and copper tube)				
FAN	Type x Quantity		Turbo fan x 1	Turbo fan x 1	Turbo fan x 1	Turbo fan x 1	
	External static press.	Pa	0	0	0	0	
		mmHzO	0	0	0	0	
	Motor type		DC motor				
	Motor output	kW	0.050	0.050	0.050	0.050	
	Driving mechanism		Direct-drive				
	Airflow rate	(Low-Mid2-Mid1-High)		(Low-Mid2-Mid1-High)	(Low-Mid2-Mid1-High)	(Low-Mid2-Mid1-High)	(Low-Mid2-Mid1-High)
		m ³ / min	12 - 13 - 14 - 15	12 - 13 - 14 - 15	13 - 14 - 15 - 16	13 - 14 - 15 - 17	
L / s		200 - 217 - 233 - 250	200 - 217 - 233 - 250	217 - 233 - 250 - 267	217 - 233 - 250 - 283		
cfm		424 - 459 - 494 - 530	424 - 459 - 494 - 530	459 - 494 - 530 - 565	459 - 494 - 530 - 600		
Sound pressure level (measured in anechoic room)		dB <A>	(Low-Mid2-Mid1-High) 24 - 26 - 27 - 29	(Low-Mid2-Mid1-High) 24 - 26 - 27 - 29	(Low-Mid2-Mid1-High) 26 - 27 - 29 - 31	(Low-Mid2-Mid1-High) 26 - 27 - 29 - 31	
Insulation material			PS				
Air filter			PP honeycomb				
Protection device			Fuse				
Refrigerant control device			LEV				
Connectable outdoor unit			R32/R410A CITY MULTI				
Diameter of refrigerant pipe	Liquid (R410A)	mm (in.)	ø6.35 (ø1/4) Flare	ø6.35 (ø1/4) Flare	ø6.35 (ø1/4) Flare	ø6.35 (ø1/4) Flare	
	Gas (R410A)	mm (in.)	ø12.7 (ø1/2) Flare	ø12.7 (ø1/2) Flare	ø12.7 (ø1/2) Flare	ø12.7 (ø1/2) Flare	
Field drain pipe size		mm (in.)	O.D. ø32 (1-1/4) (VP-25)				
Standard attachment	Document Accessory		Installation Manual, Instruction Book				
Remark	Optional parts						
	Decoration panel **1		PLP-6EA	PLP-6EA	PLP-6EA	PLP-6EA	
	Signal receiver panel **1		PLP-6EAL	PLP-6EAL	PLP-6EAL	PLP-6EAL	
	3D i-see Sensor panel **1		PLP-6EAE	PLP-6EAE	PLP-6EAE	PLP-6EAE	
	3D i-see Sensor and signal receiver panel **1		PLP-6EALE	PLP-6EALE	PLP-6EALE	PLP-6EALE	
	Auto elevation and signal receiver panel **1		PLP-6EAJ	PLP-6EAJ	PLP-6EAJ	PLP-6EAJ	
	Auto elevation, 3D i-see Sensor and signal receiver panel **1		PLP-6EAJE	PLP-6EAJE	PLP-6EAJE	PLP-6EAJE	
	With wireless remote controller and signal receiver panel **1		PLP-6EALM	PLP-6EALM	PLP-6EALM	PLP-6EALM	
	With wireless remote controller, signal receiver and 3D i-see Sensor panel **1		PLP-6EALME	PLP-6EALME	PLP-6EALME	PLP-6EALME	
	Air outlet shutter plate		PAC-SJ37SP-E	PAC-SJ37SP-E	PAC-SJ37SP-E	PAC-SJ37SP-E	
	High efficiency filter element **2		PAC-SH59KF-E	PAC-SH59KF-E	PAC-SH59KF-E	PAC-SH59KF-E	
	Multi-function casement		PAC-SJ41TM-E	PAC-SJ41TM-E	PAC-SJ41TM-E	PAC-SJ41TM-E	
	3D i-see Sensor corner panel		PAC-SE1ME-E	PAC-SE1ME-E	PAC-SE1ME-E	PAC-SE1ME-E	
	Wireless signal receiver		PAR-SE9FA-E	PAR-SE9FA-E	PAR-SE9FA-E	PAR-SE9FA-E	
	Space panel		PAC-SJ65AS-E	PAC-SJ65AS-E	PAC-SJ65AS-E	PAC-SJ65AS-E	
	Duct flange for fresh air intake		PAC-SH65OF-E	PAC-SH65OF-E	PAC-SH65OF-E	PAC-SH65OF-E	
	V blocking filter		PAC-SK53KF-E	PAC-SK53KF-E	PAC-SK53KF-E	PAC-SK53KF-E	
	3D Total flow unit		PLP-U160ELR-E	PLP-U160ELR-E	PLP-U160ELR-E	PLP-U160ELR-E	
	Plasma Quad Connect		PAC-SK51FT-E	PAC-SK51FT-E	PAC-SK51FT-E	PAC-SK51FT-E	
			**1.PLFY-M-VEM6-E should be used together with PLP-6EA/EAL/EAE/EALJ/EAJ/EALM/EALME.				
			**2.PAC-SJ41TM-E is necessary to use with filter PAC-SH59KF-E.				
	Installation		Details on foundation work, duct work, insulation work, electrical wiring, power source switch, and other items shall be referred to the Installation Manual.				
	Note :	*1 Nominal cooling condition		*2 Nominal heating condition		Unit converter	
Indoor : 27°CDB/19°CWB (81°FDB/66°FWB)		20°CDB (68°FDB)		BTU/h = kW x 3.412			
Outdoor : 35°CDB (95°FDB)		7°CDB/6°CWB (45°FDB/43°FWB)		cfm = m ³ /min x 35.31			
Pipe length : 7.5 m (24-9/16 ft)		7.5 m (24-9/16 ft)		lbs = kg / 0.4536			
Level difference : 0 m (0 ft)		0 m (0 ft)					
* Nominal conditions *1, *2 are subject to JIS B8615-1.							
* Due to continuing improvement, above specification may be subject to change without notice.							
*Above specification data is subject to rounding variation.							

1. SPECIFICATIONS

Ceiling cassette (4-way flow type)

Model			PLFY-M50VEM6-E	PLFY-M63VEM6-E	PLFY-M71VEM6-E	PLFY-M80VEM6-E	
Power source			1-phase 220-240V 50Hz, 1-phase 220V 60Hz				
Cooling capacity (Nominal)	*1	kW	5.6	7.1	8.0	9.0	
		BTU / h	19,100	24,200	27,300	30,700	
	*1	Power input	kW	0.06	0.09	0.12	0.12
		Current input	A	0.52	0.74	0.97	0.97
Heating capacity (Nominal)	*2	kW	6.3	8.0	9.0	10.0	
		BTU / h	21,500	27,300	30,700	34,100	
	*2	Power input	kW	0.07	0.12	0.12	0.12
		Current input	A	0.60	0.90	0.94	0.94
External finish			Galvanized steel sheet				
External dimension H x W x D		mm	298 x 840 x 840				
		in.	11-3/4 x 33-3/32 x 33-3/32				
Net weight			24 (53)	24 (53)	27 (60)	27 (60)	
Decoration panel	Model		PLP-6EA	PLP-6EA	PLP-6EA	PLP-6EA	
	External finish		MUNSELL (1.0Y 9.2/0.2)				
	Dimension	mm	40 x 950 x 950				
		in.	1-9/16 x 37-13/32 x 37-13/32				
	Net weight		kg (lbs)				
Heat exchanger			Cross fin (Aluminum fin and copper tube)				
FAN	Type x Quantity		Turbo fan x 1	Turbo fan x 1	Turbo fan x 1	Turbo fan x 1	
	External static press.	Pa	0	0	0	0	
		mmH ₂ O	0	0	0	0	
	Motor type		DC motor				
	Motor output	kW	0.120	0.120	0.120	0.120	
	Driving mechanism		Direct-drive				
	Airflow rate	(Low-Mid2-Mid1-High)		(Low-Mid2-Mid1-High)	(Low-Mid2-Mid1-High)	(Low-Mid2-Mid1-High)	
		m ³ / min	16 - 17 - 18 - 25 (Cooling) 16 - 17 - 18 - 28 (Heating)	16 - 18 - 20 - 32 (Cooling) 16 - 18 - 20 - 35 (Heating)	16 - 18 - 20 - 35	16 - 20 - 23 - 35	
		L / s	267 - 283 - 300 - 417 (Cooling) 267 - 283 - 300 - 467 (Heating)	267 - 300 - 333 - 533 (Cooling) 267 - 300 - 333 - 583 (Heating)	267 - 300 - 333 - 583	267 - 333 - 383 - 583	
	cfm	565 - 600 - 636 - 883 (Cooling) 565 - 600 - 636 - 989 (Heating)	565 - 636 - 706 - 1130 (Cooling) 565 - 636 - 706 - 1236 (Heating)	565 - 636 - 706 - 1236	565 - 706 - 812 - 1236		
Sound pressure level		(Low-Mid2-Mid1-High)	(Low-Mid2-Mid1-High)	(Low-Mid2-Mid1-High)	(Low-Mid2-Mid1-High)		
(measured in anechoic room)		dB <A>	27 - 29 - 31 - 38 (Cooling) 27 - 29 - 31 - 41 (Heating)	27 - 30 - 32 - 43 (Cooling) 27 - 30 - 32 - 46 (Heating)	28 - 31 - 35 - 46	28 - 33 - 37 - 46	
Insulation material			PS				
Air filter			PP honeycomb				
Protection device			Fuse				
Refrigerant control device			LEV				
Connectable outdoor unit			R32/R410A CITY MULTI				
Diameter of refrigerant pipe	Liquid (R410A)	mm (in.)	ø6.35 (ø1/4) Flare	ø9.52 (ø3/8) Flare	ø9.52 (ø3/8) Flare	ø9.52 (ø3/8) Flare	
	Gas (R410A)	mm (in.)	ø12.7 (ø1/2) Flare	ø15.88 (ø5/8) Flare	ø15.88 (ø5/8) Flare	ø15.88 (ø5/8) Flare	
Field drain pipe size		mm (in.)	O.D. ø32 (1-1/4) (VP-25)				
Standard attachment			Document Accessory				
Remark			Installation Manual, Instruction Book				
Optional parts							
Decoration panel **1			PLP-6EA	PLP-6EA	PLP-6EA	PLP-6EA	
Signal receiver panel **1			PLP-6EAL	PLP-6EAL	PLP-6EAL	PLP-6EAL	
3D i-see Sensor panel **1			PLP-6EAE	PLP-6EAE	PLP-6EAE	PLP-6EAE	
3D i-see Sensor and signal receiver panel **1			PLP-6EALAE	PLP-6EALAE	PLP-6EALAE	PLP-6EALAE	
Auto elevation and signal receiver panel **1			PLP-6EAJ	PLP-6EAJ	PLP-6EAJ	PLP-6EAJ	
Auto elevation, 3D i-see Sensor and signal receiver panel **1			PLP-6EAJE	PLP-6EAJE	PLP-6EAJE	PLP-6EAJE	
With wireless remote controller and signal receiver panel **1			PLP-6EALM	PLP-6EALM	PLP-6EALM	PLP-6EALM	
With wireless remote controller, signal receiver and 3D i-see Sensor panel **1			PLP-6EALME	PLP-6EALME	PLP-6EALME	PLP-6EALME	
Air outlet shutter plate			PAC-SJ37SP-E	PAC-SJ37SP-E	PAC-SJ37SP-E	PAC-SJ37SP-E	
High efficiency filter element **2			PAC-SH59KF-E	PAC-SH59KF-E	PAC-SH59KF-E	PAC-SH59KF-E	
Multi-function casement			PAC-SJ41TM-E	PAC-SJ41TM-E	PAC-SJ41TM-E	PAC-SJ41TM-E	
3D i-see Sensor corner panel			PAC-SE1ME-E	PAC-SE1ME-E	PAC-SE1ME-E	PAC-SE1ME-E	
Wireless signal receiver			PAR-SE9FA-E	PAR-SE9FA-E	PAR-SE9FA-E	PAR-SE9FA-E	
Space panel			PAC-SJ65AS-E	PAC-SJ65AS-E	PAC-SJ65AS-E	PAC-SJ65AS-E	
Duct flange for fresh air intake			PAC-SH65OF-E	PAC-SH65OF-E	PAC-SH65OF-E	PAC-SH65OF-E	
V blocking filter			PAC-SK53KF-E	PAC-SK53KF-E	PAC-SK53KF-E	PAC-SK53KF-E	
3D Total flow unit			PLP-U160ELR-E	PLP-U160ELR-E	PLP-U160ELR-E	PLP-U160ELR-E	
Plasma Quad Connect			PAC-SK51FT-E	PAC-SK51FT-E	PAC-SK51FT-E	PAC-SK51FT-E	
			**1.PLFY-M-VEM6-E should be used together with PLP-6EA/EAL/EAE/EALAE/EAJ/EAJE/EALM/EALME.				
			**2.PAC-SJ41TM-E is necessary to use with filter PAC-SH59KF-E.				
Installation			Details on foundation work, duct work, insulation work, electrical wiring, power source switch, and other items shall be referred to the Installation Manual.				
Note :		*1 Nominal cooling condition	*2 Nominal heating condition		Unit converter		
Indoor :		27°CDB/19°CWB (81°FDB/66°FWB)	20°CDB (68°FDB)		BTU/h = kW x 3.412		
Outdoor :		35°CDB (95°FDB)	7°CDB/6°CWB (45°FDB/43°FWB)		cfm = m ³ /min x 35.31		
Pipe length :		7.5 m (24-9/16 ft)	7.5 m (24-9/16 ft)		lbs = kg / 0.4536		
Level difference :		0 m (0 ft)	0 m (0 ft)				
* Nominal conditions *1, *2 are subject to JIS B8615-1.							
* Due to continuing improvement, above specification may be subject to change without notice.							
						*Above specification data is subject to rounding variation.	

1. SPECIFICATIONS

Ceiling cassette (4-way flow type)

PLFY-M-VEM6-E

Model			PLFY-M100VEM6-E			PLFY-M125VEM6-E			
Power source			1-phase 220-240V 50Hz, 1-phase 220V 60Hz						
Cooling capacity (Nominal)	*1	kW	11.2			14.0			
		BTU / h	38,200			47,800			
	Power input	kW	0.12			0.12			
		Current input	A	0.97			0.97		
Heating capacity (Nominal)	*2	kW	12.5			16.0			
		BTU / h	42,700			54,600			
	Power input	kW	0.12			0.12			
		Current input	A	0.94			0.94		
External finish			Galvanized steel sheet						
External dimension H x W x D		mm	298 x 840 x 840						
		in.	11-3/4 x 33-3/32 x 33-3/32						
Net weight		kg (lbs)	27 (60)			27 (60)			
Decoration panel	Model		PLP-6EA			PLP-6EA			
	External finish		MUNSELL (1.0Y 9.2/0.2)						
	Dimension	mm	40 x 950 x 950						
		in.	1-9/16 x 37-13/32 x 37-13/32						
	Net weight		kg (lbs)	5 (11)					
Heat exchanger			Cross fin (Aluminum fin and copper tube)						
FAN	Type x Quantity		Turbo fan x 1			Turbo fan x 1			
	External static press.	Pa	0			0			
		mmH ₂ O	0			0			
	Motor type		DC motor						
	Motor output	kW	0.120			0.120			
	Driving mechanism		Direct-drive						
	Airflow rate			(Low-Mid2-Mid1-High)			(Low-Mid2-Mid1-High)		
		m ³ / min	17 - 22 - 28 - 35			17 - 24 - 31 - 35			
L / s		283 - 367 - 467 - 583			283 - 400 - 517 - 583				
cfm		600 - 777 - 989 - 1236			600 - 847 - 1095 - 1236				
Sound pressure level (measured in anechoic room)		dB <A>	(Low-Mid2-Mid1-High) 29 - 35 - 41 - 46			(Low-Mid2-Mid1-High) 30 - 37 - 45 - 46			
Insulation material			PS						
Air filter			PP honeycomb						
Protection device			Fuse						
Refrigerant control device			LEV						
Connectable outdoor unit			R32/R410A CITY MULTI						
Diameter of refrigerant pipe	Liquid (R410A)	mm (in.)	ø9.52 (ø3/8) Flare			ø9.52 (ø3/8) Flare			
	Gas (R410A)	mm (in.)	ø15.88 (ø5/8) Flare			ø15.88 (ø5/8) Flare			
Field drain pipe size		mm (in.)	O.D. ø32 (1-1/4) (VP-25)						
Standard attachment	Document Accessory	Installation Manual, Instruction Book							
Remark	Optional parts								
	Decoration panel **1		PLP-6EA			PLP-6EA			
	Signal receiver panel **1		PLP-6EAL			PLP-6EAL			
	3D i-see Sensor panel **1		PLP-6EAE			PLP-6EAE			
	3D i-see Sensor and signal receiver panel **1		PLP-6EAL E			PLP-6EAL E			
	Auto elevation and signal receiver panel **1		PLP-6EAJ			PLP-6EAJ			
	Auto elevation, 3D i-see Sensor and signal receiver panel **1		PLP-6EAJE			PLP-6EAJE			
	With wireless remote controller and signal receiver panel **1		PLP-6EALM			PLP-6EALM			
	With wireless remote controller, signal receiver and 3D i-see Sensor panel **1		PLP-6EALME			PLP-6EALME			
	Air outlet shutter plate		PAC-SJ37SP-E			PAC-SJ37SP-E			
	High efficiency filter element **2		PAC-SH59KF-E			PAC-SH59KF-E			
	Multi-function casement		PAC-SJ41TM-E			PAC-SJ41TM-E			
	3D i-see Sensor corner panel		PAC-SE1ME-E			PAC-SE1ME-E			
	Wireless signal receiver		PAR-SE9FA-E			PAR-SE9FA-E			
	Space panel		PAC-SJ65AS-E			PAC-SJ65AS-E			
	Duct flange for fresh air intake		PAC-SH65OF-E			PAC-SH65OF-E			
	V blocking filter		PAC-SK53KF-E			PAC-SK53KF-E			
	3D Total flow unit		PLP-U160ELR-E			PLP-U160ELR-E			
	Plasma Quad Connect		PAC-SK51FT-E			PAC-SK51FT-E			
			**1.PLFY-M-VEM6-E should be used together with PLP-6EA/EAL/EAE/EAL E/EAJ/EAJE/EALM/EALME. **2.PAC-SJ41TM-E is necessary to use with filter PAC-SH59KF-E.						
	Installation		Details on foundation work, duct work, insulation work, electrical wiring, power source switch, and other items shall be referred to the Installation Manual.						
	Note :	*1 Nominal cooling condition		*2 Nominal heating condition			Unit converter		
		Indoor : 27°CDB/19°CWB (81°FDB/66°FWB)		20°CDB (68°FDB)			BTU/h = kW x 3.412		
Outdoor : 35°CDB (95°FDB)		7°CDB/6°CWB (45°FDB/43°FWB)			cfm = m ³ /min x 35.31				
Pipe length : 7.5 m (24-9/16 ft)		7.5 m (24-9/16 ft)			lbs = kg / 0.4536				
Level difference : 0 m (0 ft)		0 m (0 ft)							
* Nominal conditions *1, *2 are subject to JIS B8615-1.									
* Due to continuing improvement, above specification may be subject to change without notice.									
*Above specification data is subject to rounding variation.									

PLFY-M20, 25, 32, 40, 50, 63, 71, 80, 100, 125VEM6-E

Unit: mm

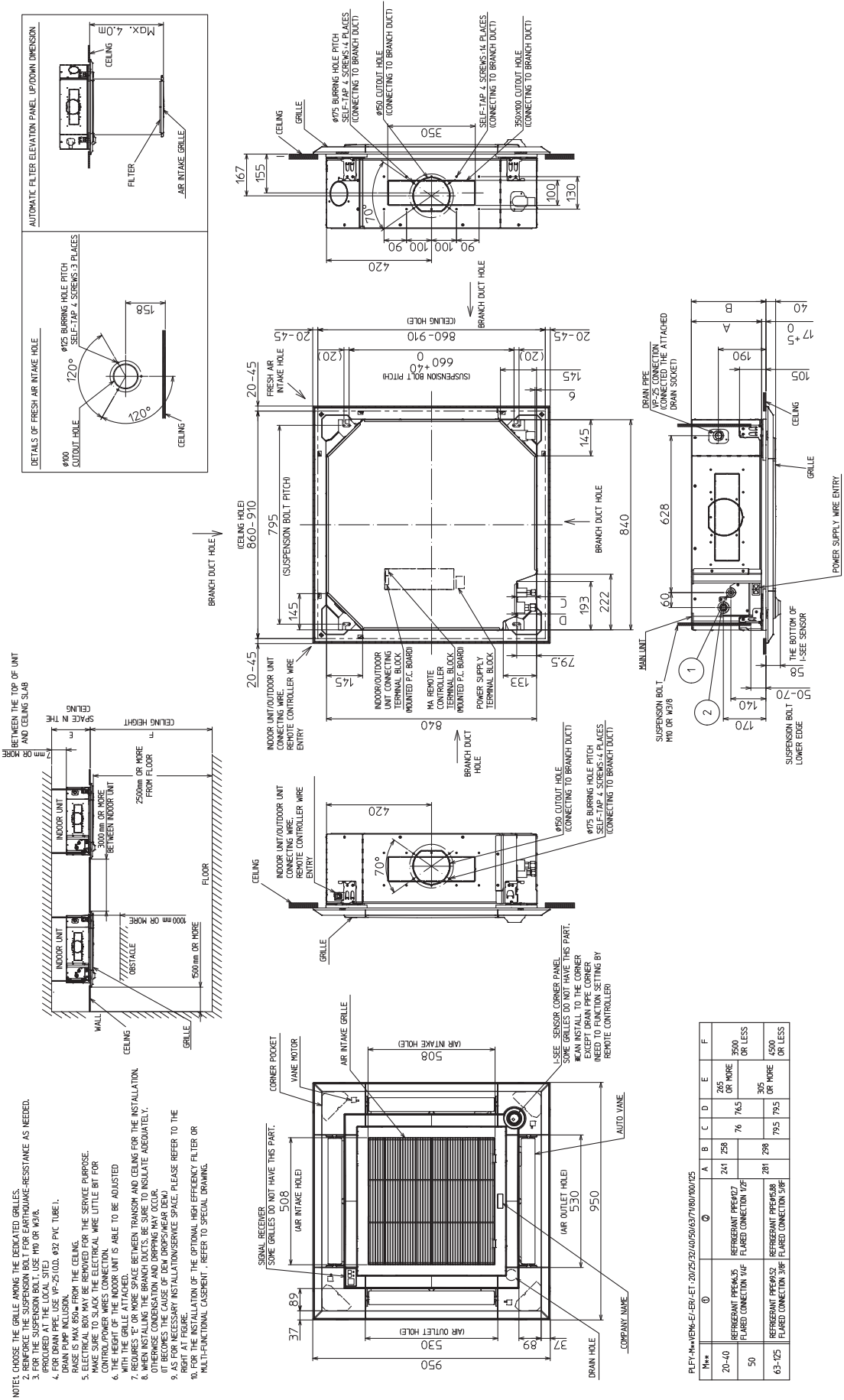

- NOTE: CHOOSE THE GRILLE AMONG THE DEDICATED GRILLES. (FROM AIR RESISTANCE AS NEEDED.)
- 1. FOR THE SUSPENSION BOLT USE #10 OR #12.
- 2. FOR THE SUSPENSION BOLT USE #10 OR #12.
- 3. FOR THE SUSPENSION BOLT USE #10 OR #12.
- 4. FOR DRAIN PIPE USE VP-25 (O.D. #2 PVC TUBE).
- 5. DRAIN PIPE INCLUSION.
- 6. MAKE SURE TO SLACK THE ELECTRICAL WIRE LITTLE BIT FOR CONTROL/POWER WIRES CONNECTION.
- 7. WITH THE GRILLE ATTACHED, THE HEIGHT OF THE INDOOR UNIT IS ABLE TO BE ADJUSTED.
- 8. WHEN INSTALLING THE BRANCH DUCTS, BE SURE TO INSULATE ADEQUATELY.
- 9. OTHERWISE CONDENSATION AND DRIPPING MAY OCCUR.
- 10. IT BECOMES THE CAUSE OF DEW DROPS/WEAR DREW.
- 11. AS FOR NECESSARY INSTALLATION/SERVICE SPACE, PLEASE REFER TO THE FIGURE.
- 12. FOR THE INSTALLATION OF THE OPTIONAL HIGH EFFICIENCY FILTER OR MULTI-FUNCTIONAL CASENET, REFER TO SPECIAL DRAWING.

PLFY-M-VEM6-E-ER-ET-20/25/32/40/50/63/71/80/100/125

Part No.	Q	A	B	C	D	E	F
20-40	REFRIGERANT PIPE#KJ5 FLARED CONNECTION 1/2"	241	258	76	76.5	265	3500 OR MORE
50	REFRIGERANT PIPE#KJ5 FLARED CONNECTION 1/2"	281	298	76	76.5	305	3500 OR LESS
63-125	REFRIGERANT PIPE#KJ58 FLARED CONNECTION 3/8"	281	298	76.5	79.5	305	4500 OR MORE OR LESS

PLFY-M-VEM6-E

PLFY-M20, 25, 32, 40, 50, 63, 71, 80, 100, 125VEM6-E

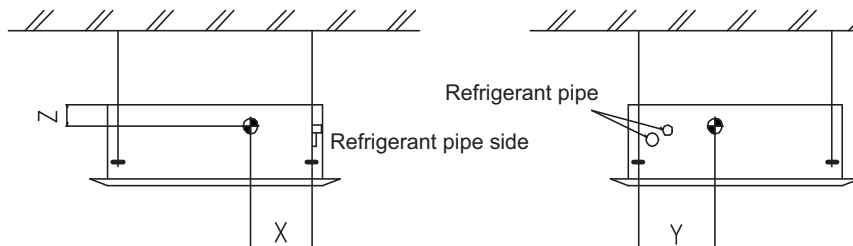

(mm)[in]

Model name	X	Y	Z
PLFY-M20VEM6-E	325 [12-13/16]	390 [15-3/8]	115 [4-17/32]
PLFY-M25VEM6-E	325 [12-13/16]	390 [15-3/8]	115 [4-17/32]
PLFY-M32VEM6-E	325 [12-13/16]	390 [15-3/8]	115 [4-17/32]
PLFY-M40VEM6-E	325 [12-13/16]	390 [15-3/8]	115 [4-17/32]
PLFY-M50VEM6-E	405 [15-15/16]	390 [15-3/8]	100 [3-15/16]
PLFY-M63VEM6-E	405 [15-15/16]	390 [15-3/8]	100 [3-15/16]
PLFY-M71VEM6-E	410 [16-1/8]	415 [16-11/32]	110 [4-5/16]
PLFY-M80VEM6-E	410 [16-1/8]	415 [16-11/32]	110 [4-5/16]
PLFY-M100VEM6-E	410 [16-1/8]	415 [16-11/32]	110 [4-5/16]
PLFY-M125VEM6-E	410 [16-1/8]	415 [16-11/32]	110 [4-5/16]

PLFY-M20, 25, 32, 40, 50, 63, 71, 80, 100, 125VEM6-E

[LEGEND]

SYMBOL	NAME	SYMBOL	NAME
I.B	INDOOR CONTROLLER BOARD	MV	VANE MOTOR
CN27	CONNECTOR DAMPER	TH21	THERMISTOR ROOM TEMP. DETECTION (0°C/15kΩ, 25°C/5.4kΩ)
CN32	CONNECTOR REMOTE SWITCH	TH22	THERMISTOR PIPE TEMP. DETECTION / LIQUID (0°C/15kΩ, 25°C/5.4kΩ)
CN51	CONNECTOR CENTRALLY CONTROL	TH23	THERMISTOR PIPE TEMP. DETECTION / GAS (0°C/15kΩ, 25°C/5.4kΩ)
CN52	CONNECTOR REMOTE INDICATION		
CN105	CONNECTOR IT TERMINAL		
F1	FUSE (T 6.3AL 250V)	TB2	TERMINAL POWER SUPPLY
SW1	SWITCH MODE SELECTION	TB5	TERMINAL BLOCK TRANSMISSION
SW2	SWITCH CAPACITY CODE	TB15	TERMINAL BLOCK MA-REMOTE CONTROLLER
SW3	SWITCH MODE SELECTION		
SW11	SWITCH ADDRESS SETTING 1s DIGIT	OPTION PART	
SW12	SWITCH ADDRESS SETTING 10s DIGIT	W.B	PCB FOR WIRELESS REMOTE CONTROLLER
SW14	SWITCH BRANCH NO.	BZ	BUZZER
SW21	SWITCH CEILING HEIGHT DISCHARGE OUTLET NUMBER OPTION SELECTOR	LED1	LED (OPERATION INDICATION : GREEN)
SW22	SWITCH PAIR NO. SETTING	LED2	LED (PREPARATION FOR HEATING : ORANGE)
SWE	SWITCH DRAIN PUMP (TEST MODE)	RU	RECEIVING UNIT
DP	DRAIN PUMP	SW1	EMERGENCY OPERATION (HEAT / DOWN)
FS	DRAIN FLOAT SWITCH	SW2	EMERGENCY OPERATION (COOL / UP)
LEV	LINEAR EXPANSION VALVE	MT	see Sensor MOTOR
MF	FAN MOTOR		

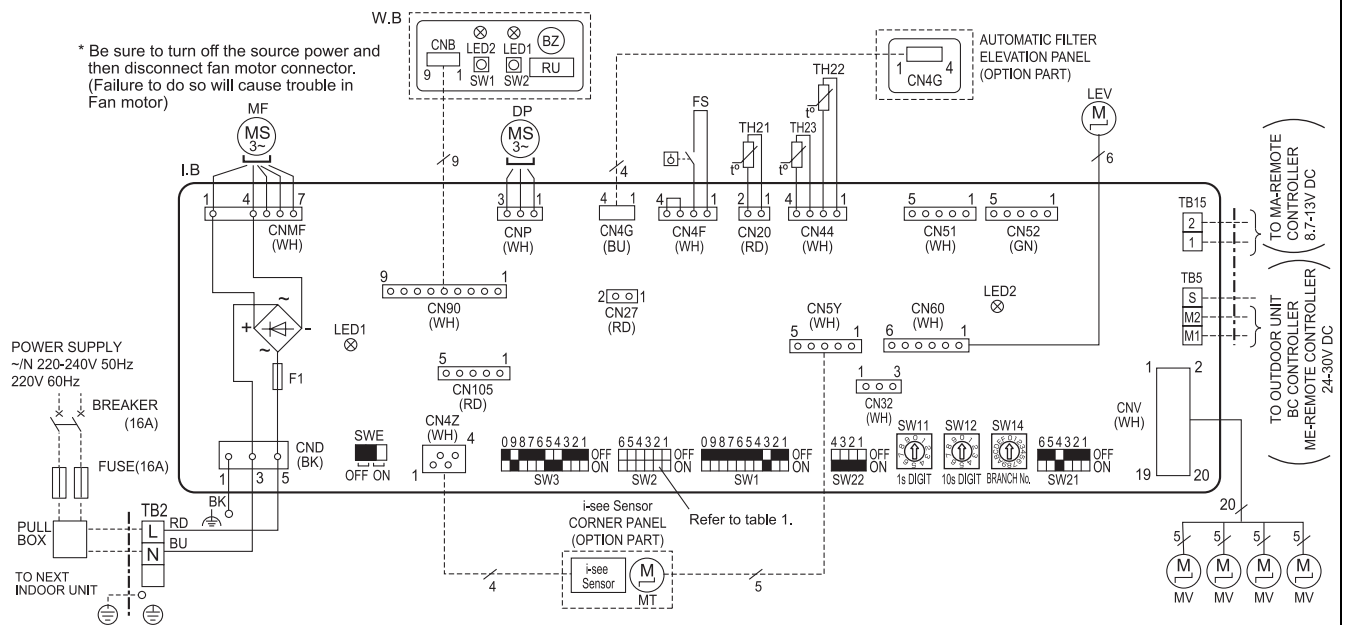

- NOTES:
- At servicing for outdoor unit, always follow the wiring diagram of outdoor unit.
 - In case of using MA-Remote controller, please connect to TB15. (Remote controller wire is non-polar.)
 - In case of using ME-Remote controller, please connect to TB5. (Transmission line is non-polar.)
 - Symbol [S] of TB5 is the shield wire connection.
 - Symbols used in wiring diagram above are,
 □ □ □ : terminal block, □ ○ □ □ : connector.
 - The setting of SW2 differs in the capacity and model. For the detail, refer to the table 1.
 - Make sure to turn off the indoor and the outdoor units before replacing indoor controller board.
 - is the switch position.

<Table 1> SW2 (CAPACITY CODE)

MODELS	SW2	MODELS	SW2	MODELS	SW2	MODELS	SW2
20	ON OFF 1 2 3 4 5 6	40	ON OFF 1 2 3 4 5 6	71	ON OFF 1 2 3 4 5 6	125	ON OFF 1 2 3 4 5 6
25	ON OFF 1 2 3 4 5 6	50	ON OFF 1 2 3 4 5 6	80	ON OFF 1 2 3 4 5 6		
32	ON OFF 1 2 3 4 5 6	63	ON OFF 1 2 3 4 5 6	100	ON OFF 1 2 3 4 5 6		

LED on indoor board for service

Mark	Meaning	Function
LED1	Main power supply	Main Power supply (Indoor unit:220-240V AC) power on → lamp is lit
LED2	Power supply for MA-Remote controller	Power supply for MA-Remote controller on → lamp is lit

5-1. Sound levels

PLFY-M-VEM6-E

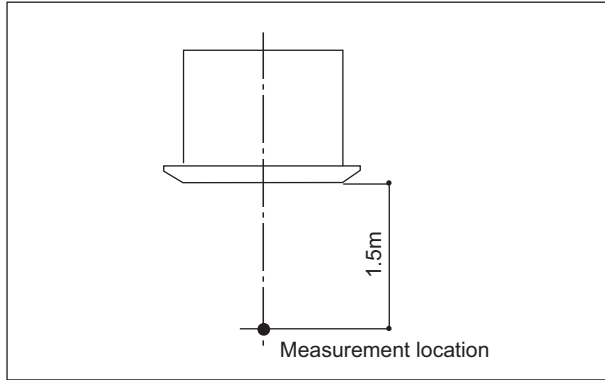

Sound level at anechoic room : Low-Mid2-Mid1-High

	Sound level dB (A)
PLFY-M20VEM6-E	24-26-27-29
PLFY-M25VEM6-E	24-26-27-29
PLFY-M32VEM6-E	26-27-29-31
PLFY-M40VEM6-E	26-27-29-31
PLFY-M50VEM6-E	27-29-31-38 (Cooling)
	27-29-31-41 (Heating)
PLFY-M63VEM6-E	27-30-32-43 (Cooling)
	27-30-32-46 (Heating)
PLFY-M71VEM6-E	28-31-35-46
PLFY-M80VEM6-E	28-33-37-46
PLFY-M100VEM6-E	29-35-41-46
PLFY-M125VEM6-E	30-37-45-46

* Measured in anechoic room.

PLFY-M-VEM6-E

5-2. NC curves

PLFY-M20, 25VEM6-E

Cooling/Heating

External Static Pressure: 0Pa [0.00in.WG]

Power Source: 220,230,240V, 50Hz/220V, 60Hz

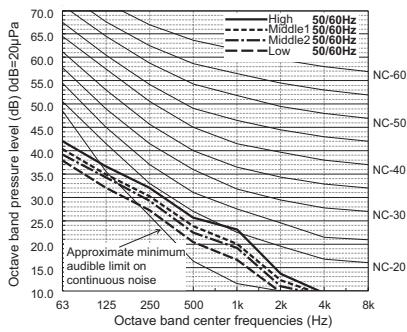

PLFY-M32, 40VEM6-E

Cooling/Heating

External Static Pressure: 0Pa [0.00in.WG]

Power Source: 220,230,240V, 50Hz/220V, 60Hz

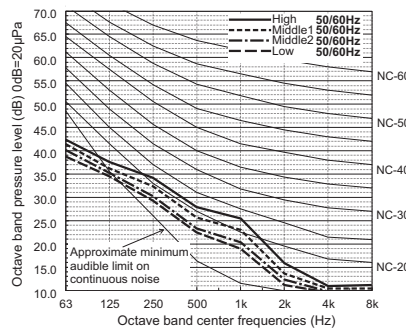

PLFY-M50VEM6-E

Cooling

External Static Pressure: 0Pa [0.00in.WG]

Power Source: 220,230,240V, 50Hz/220V, 60Hz

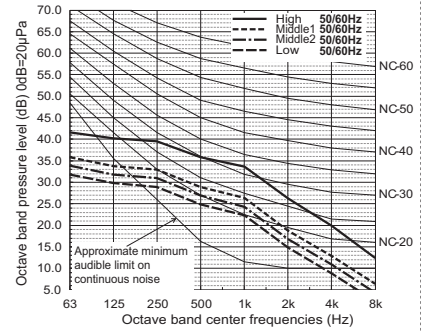

PLFY-M50VEM6-E

Heating

External Static Pressure: 0Pa [0.00in.WG]

Power Source: 220,230,240V, 50Hz/220V, 60Hz

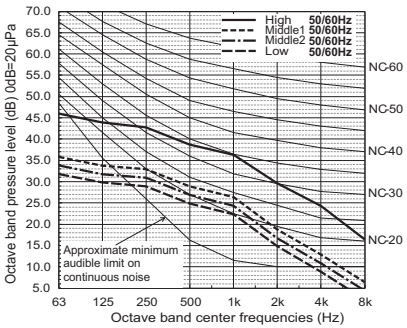

PLFY-M63VEM6-E

Cooling

External Static Pressure: 0Pa [0.00in.WG]

Power Source: 220,230,240V, 50Hz/220V, 60Hz

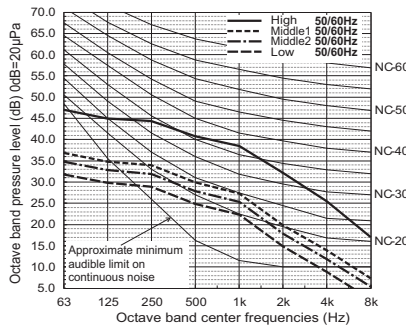

PLFY-M63VEM6-E

Heating

External Static Pressure: 0Pa [0.00in.WG]

Power Source: 220,230,240V, 50Hz/220V, 60Hz

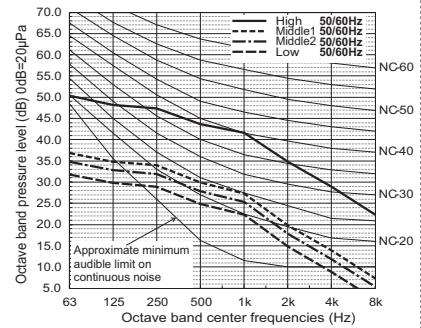

PLFY-M71VEM6-E

Cooling/Heating

External Static Pressure: 0Pa [0.00in.WG]

Power Source: 220,230,240V, 50Hz/220V, 60Hz

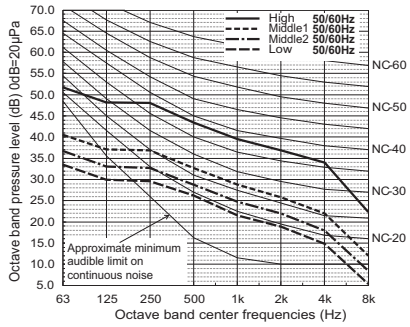

PLFY-M80VEM6-E

Cooling/Heating

External Static Pressure: 0Pa [0.00in.WG]

Power Source: 220,230,240V, 50Hz/220V, 60Hz

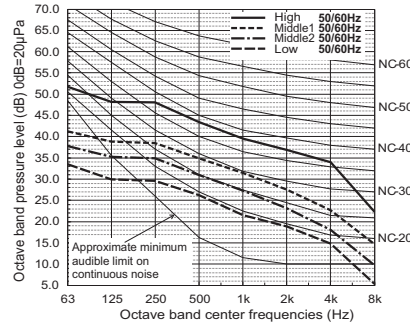

PLFY-M100VEM6-E

Cooling/Heating

External Static Pressure: 0Pa [0.00in.WG]

Power Source: 220,230,240V, 50Hz/220V, 60Hz

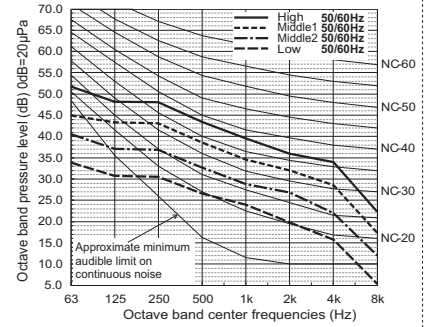

PLFY-M125VEM6-E

Cooling/Heating

External Static Pressure: 0Pa [0.00in.WG]

Power Source: 220,230,240V, 50Hz/220V, 60Hz

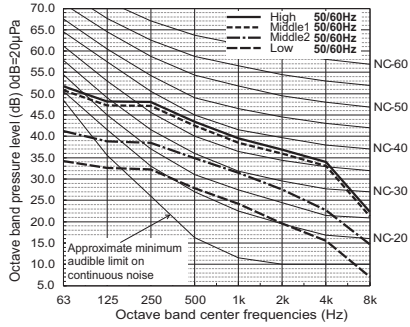

PLFY-M-VEM6-E

6-1. Temperature distributions

PLFY-M40VEM6-E

<Cooling mode> Standard
 Flow angle : 10° 4-way flow
 Ceiling height : 2.7m

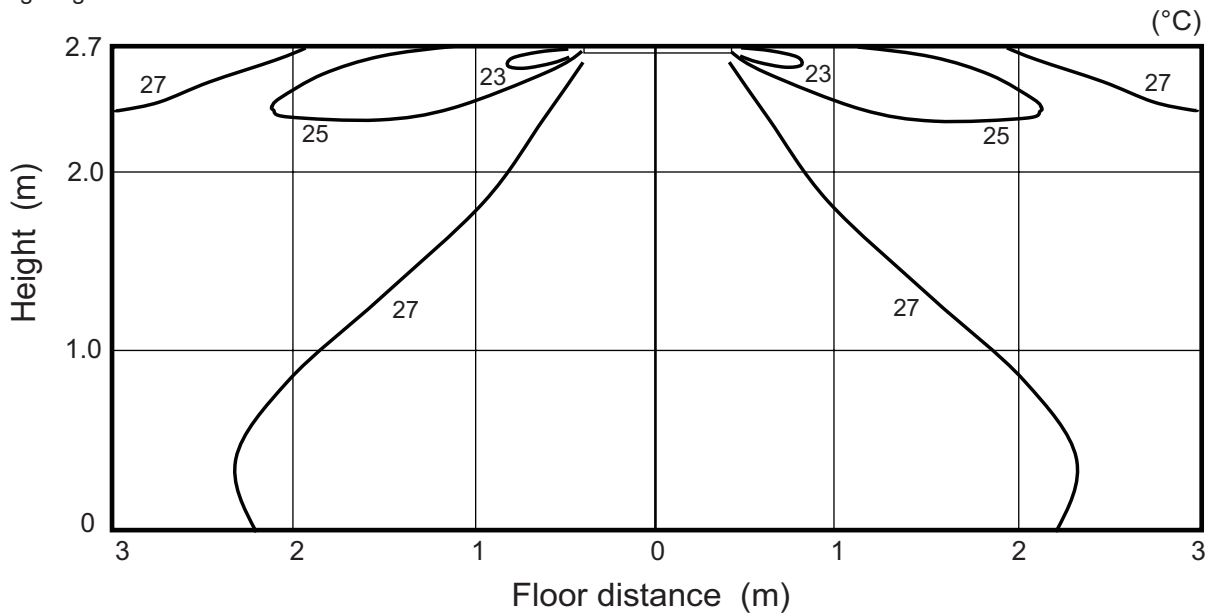

<Heating mode> Standard
 Flow angle : 60° 4-way flow
 Ceiling height : 2.7m

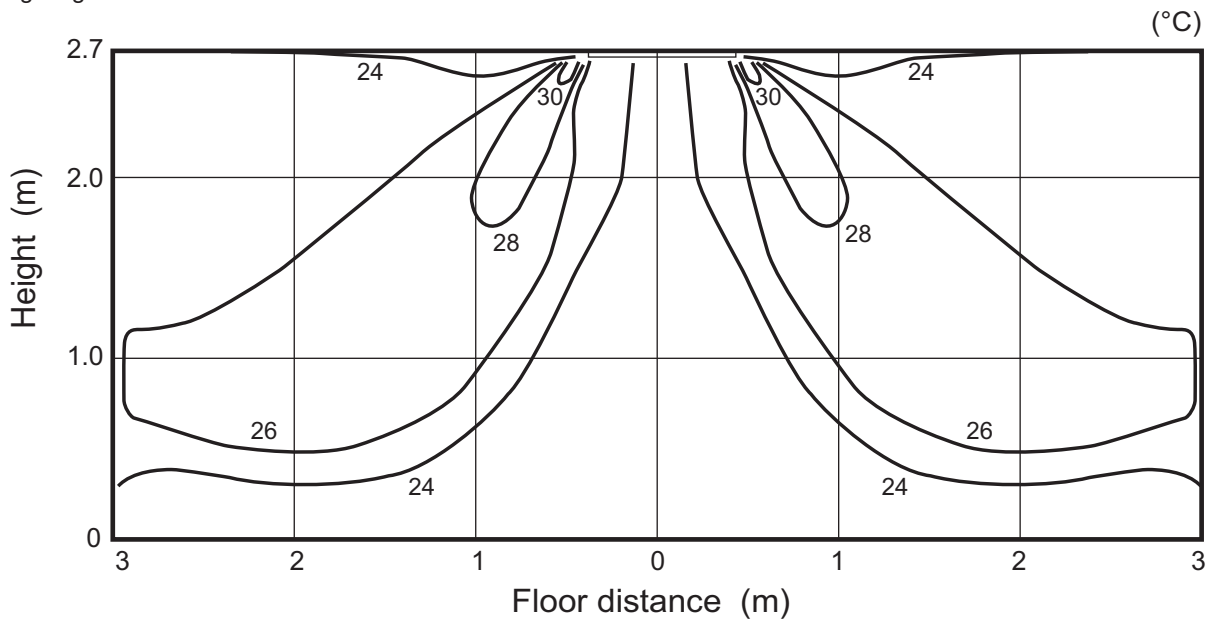

Note : These figures show typical temperature distributions in the conditions above. In the actual installation, they may differ from these figures under the influence of air temperature conditions, ceiling height, cooling/heating load, obstacles, etc.

PLFY-M-VEM6-E

PLFY-M125VEM6-E

<Cooling mode> Standard
 Flow angle : 10° 4-way flow
 Ceiling height : 2.7m

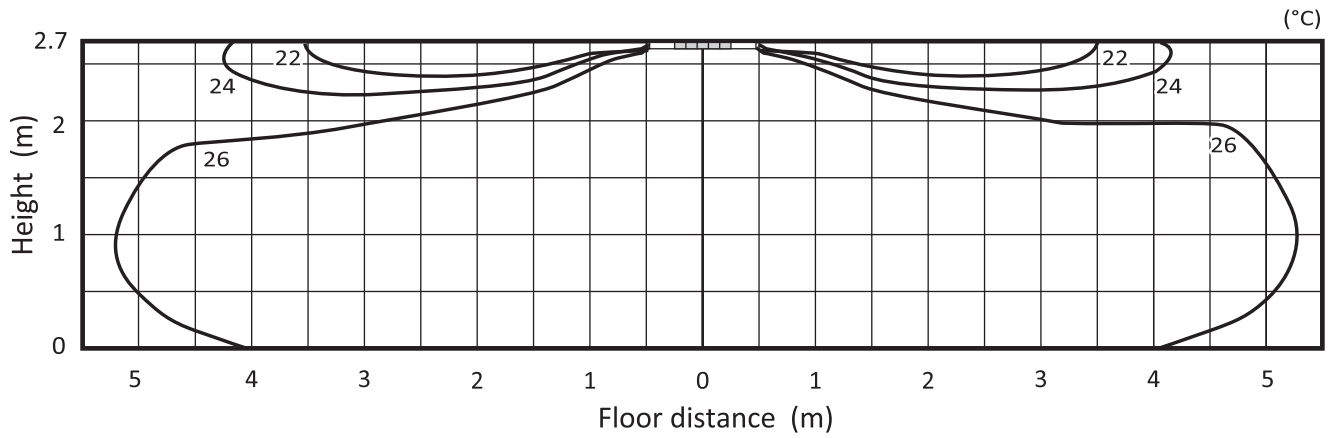

<Heating mode> Standard
 Flow angle : 60° 4-way flow
 Ceiling height : 2.7m

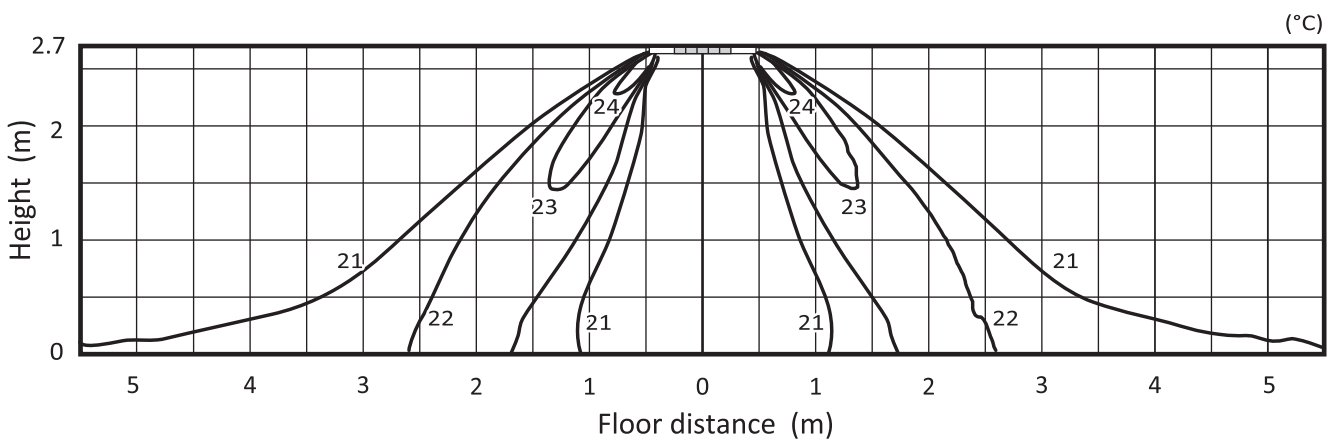

Note : These figures show typical temperature distributions in the conditions above. In the actual installation, they may differ from these figures under the influence of air temperature conditions, ceiling height, cooling/heating load, obstacles, etc.

6-2. Airflow distributions

PLFY-M40VEM6-E

<Cooling mode> Standard
 Flow angle : 10° 4-way flow
 Ceiling height : 2.7m

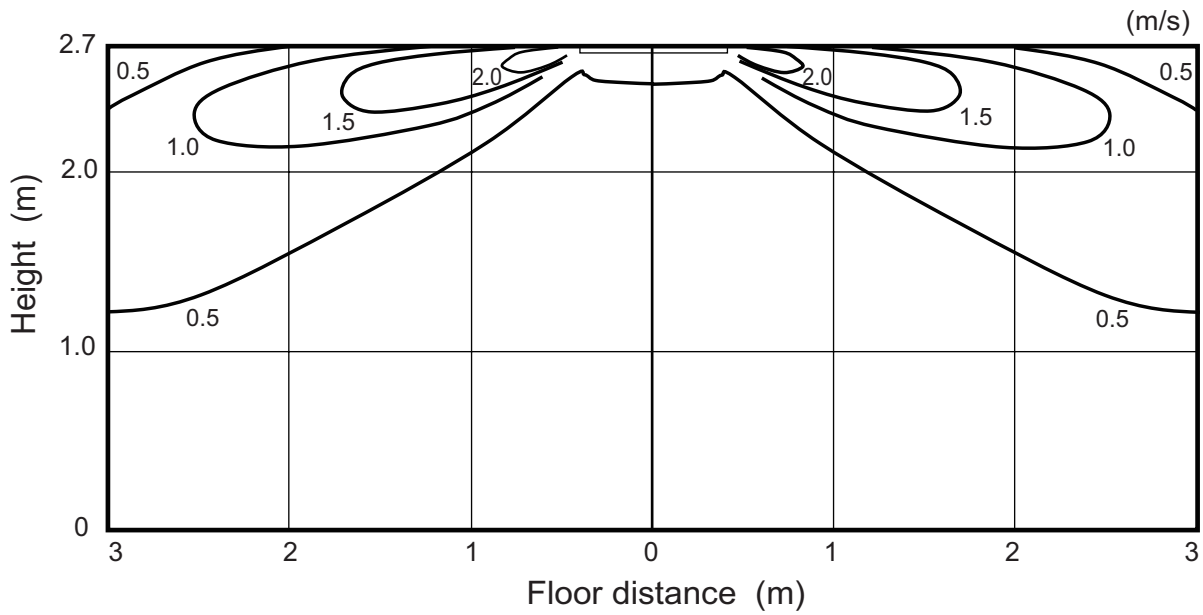

<Heating mode> Standard
 Flow angle : 60° 4-way flow
 Ceiling height : 2.7m

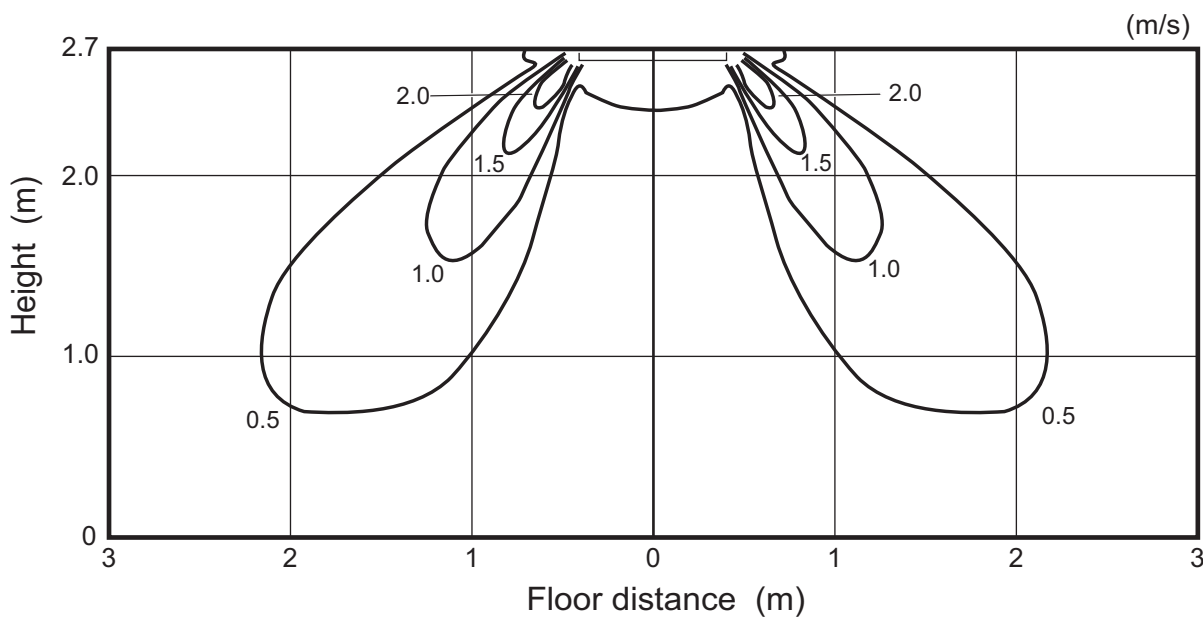

Note : These figures show typical temperature distributions in the conditions above. In the actual installation, they may differ from these figures under the influence of air temperature conditions, ceiling height, cooling/heating load, obstacles, etc.

PLFY-M-VEM6-E

PLFY-M125VEM6-E

<Cooling mode> Standard
 Flow angle : 10° 4-way flow
 Ceiling height : 2.7m

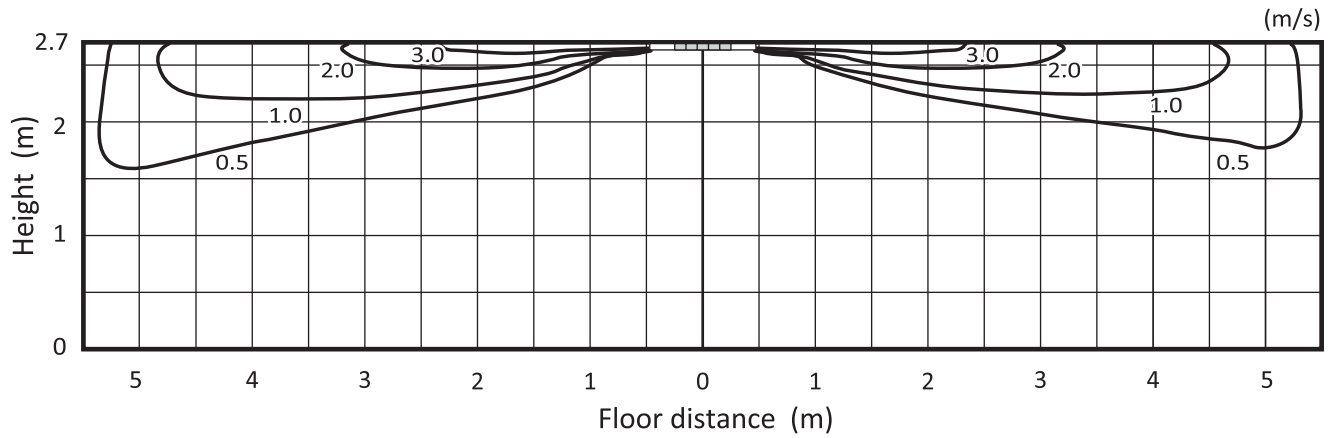

<Heating mode> Standard
 Flow angle : 60° 4-way flow
 Ceiling height : 2.7m

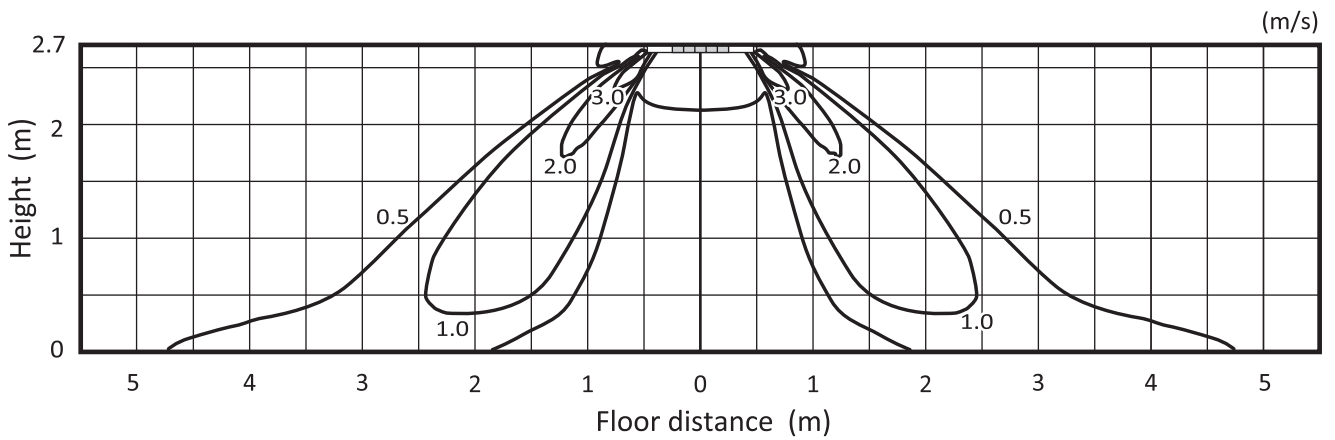

Note : These figures show typical temperature distributions in the conditions above. In the actual installation, they may differ from these figures under the influence of air temperature conditions, ceiling height, cooling/heating load, obstacles, etc.

7-1. Correction by fan speed

PLFY-M-VEM6-E

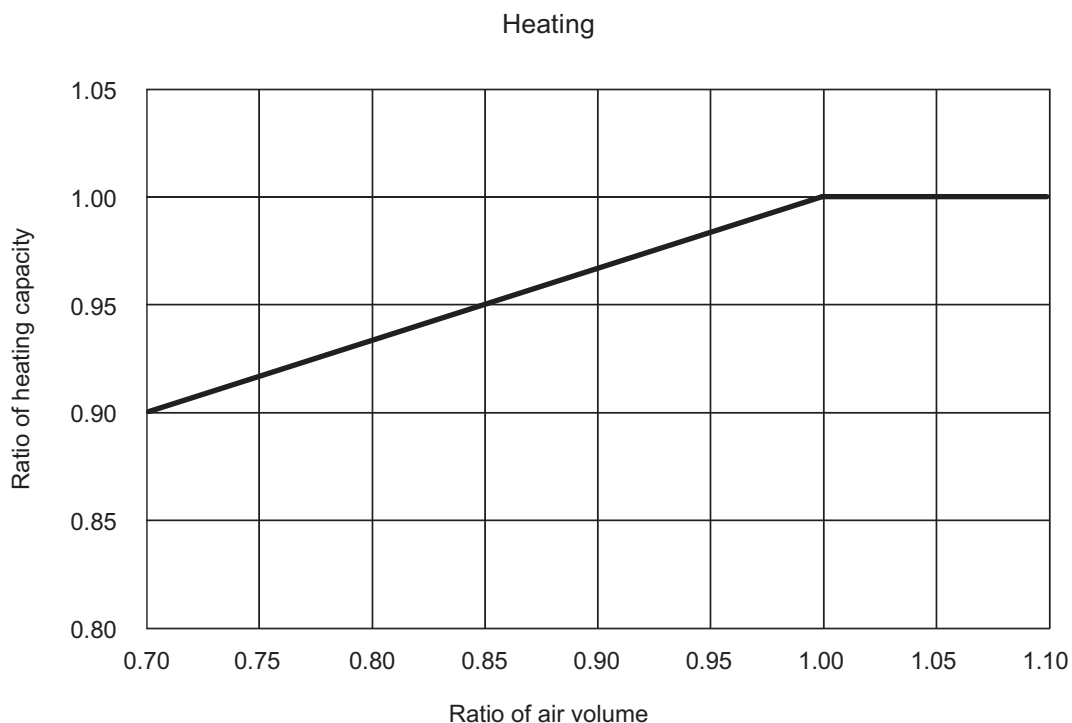
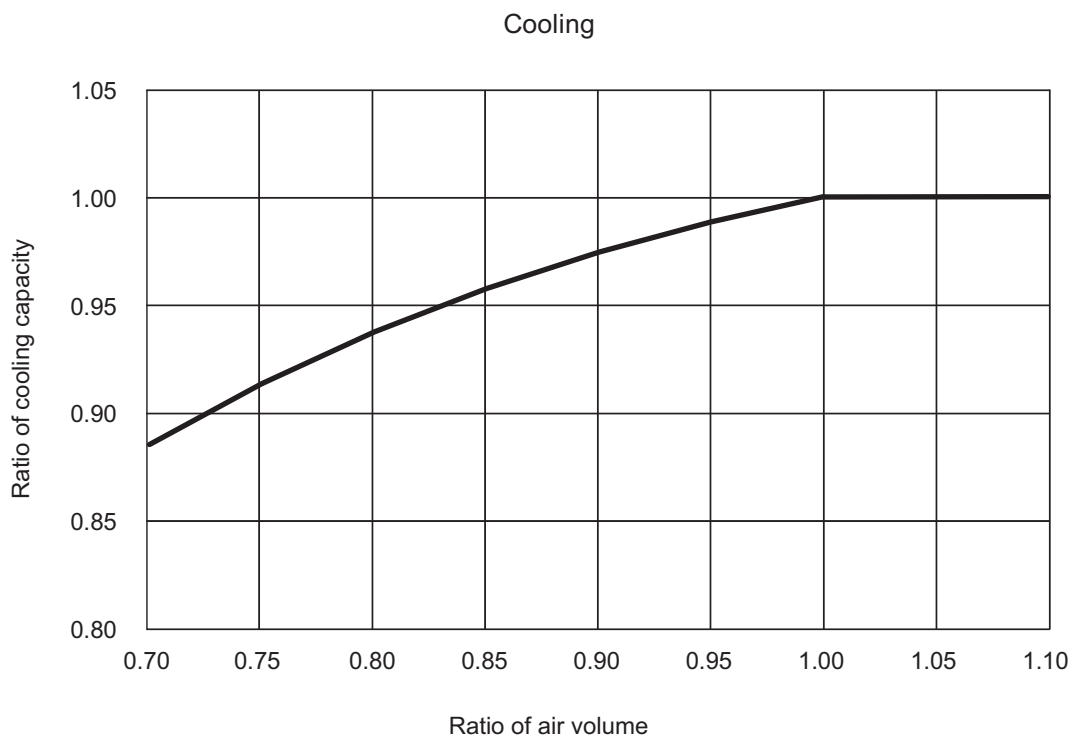

[Notes]

- The graphs only apply to the PLYF-M-VEM6-E and the PEFY-M-VMA-A1 series.
- Values in the graphs show reference values under the rated air condition and when the airflow volume of all connected indoor units is assumed to change equally.
- Values in the graphs vary, depending on the fan setting of individual units and on air conditions. The values here do not indicate guaranteed capacity.

8. ELECTRICAL CHARACTERISTICS

Ceiling cassette (4-way flow type)

Symbols: MCA (Max.Circuit Amps =1.25xFLA), FLA (Full Load Amps)
IFM (Indoor Fan Motor), Output (Fan motor rated output)

PLFY-M-VEM6-E	Power supply			IFM	
	Volts/Hz	Range +-10%	MCA(A)	Output (kW)	FLA(A)
PLFY-M20VEM6-E	220-240V/50Hz 220V/60Hz	Max.: 264V Min.: 198V	0.39	0.05	0.31
PLFY-M25VEM6-E			0.39	0.05	0.31
PLFY-M32VEM6-E			0.40	0.05	0.32
PLFY-M40VEM6-E			0.40	0.05	0.32
PLFY-M50VEM6-E			0.75	0.12	0.60
PLFY-M63VEM6-E			1.13	0.12	0.90
PLFY-M71VEM6-E			1.22	0.12	0.97
PLFY-M80VEM6-E			1.22	0.12	0.97
PLFY-M100VEM6-E			1.22	0.12	0.97
PLFY-M125VEM6-E			1.22	0.12	0.97

PLFY-M-VEM6-E

9-1. Optional parts line up for the Indoor unit

PLFY-M-VEM6-E

	Description	Model
PLFY-M-VEM6-E	Air outlet shutter plate	PAC-SJ37SP-E
	Multi-function casement	PAC-SJ41TM-E
	High efficiency filter element	PAC-SH59KF-E
	3D i-see Sensor corner panel	PAC-SE1ME-E
	Auto elevation and signal receiver panel	PLP-6EAJ
	Auto elevation, 3D i-see Sensor and signal receiver panel	PLP-6EAJE
	Wireless signal receiver	PAR-SE9FA-E
	Space panel	PAC-SJ65AS-E
	Duct flange for fresh air intake	PAC-SH65OF-E
	V blocking filter	PAC-SK53KF-E
	3D Total flow unit	PLP-U160ELR-E
	Plasma Quad Connect	PAC-SK51FT-E

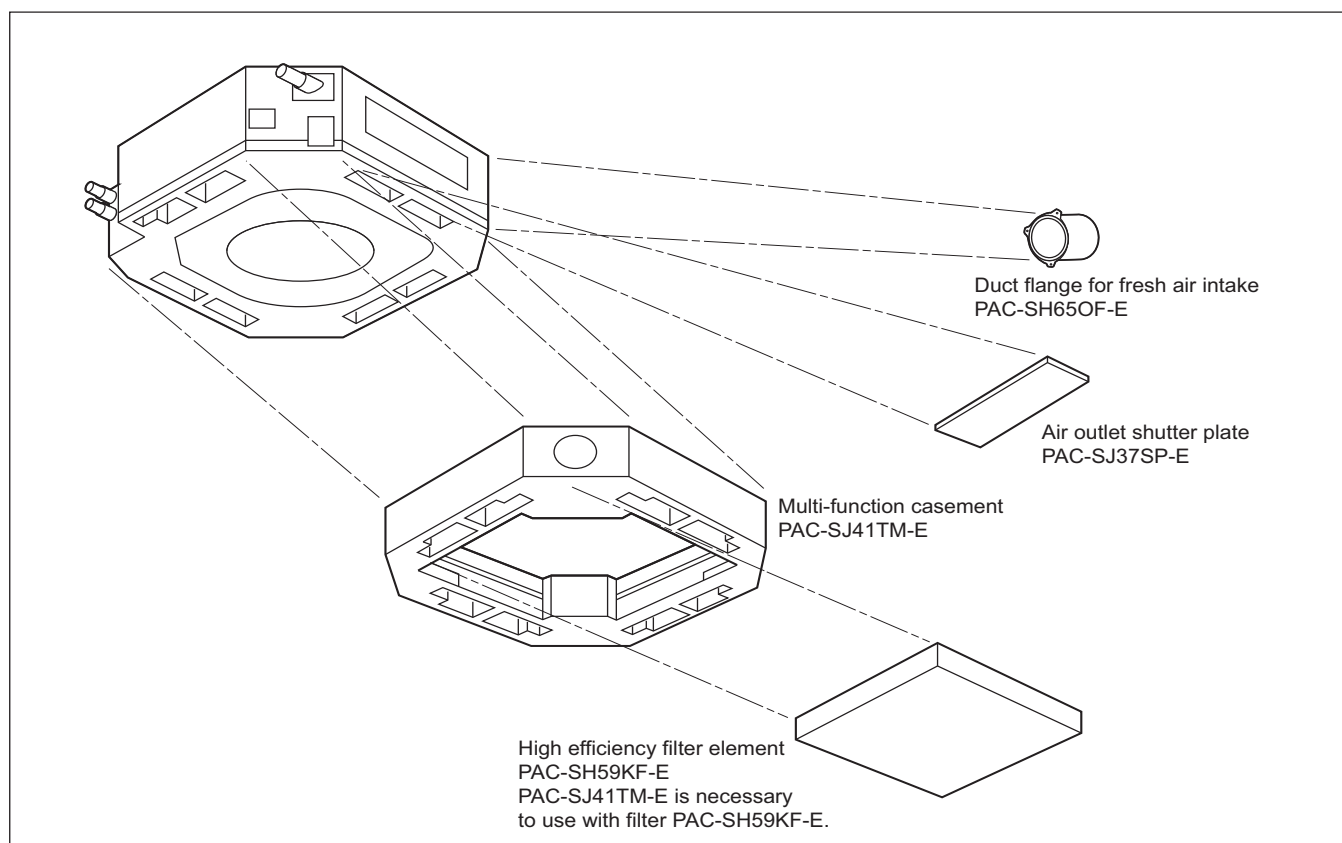

9-2. Air outlet shutter plate

Using the air outlet shutter plate to block the air outlet to modify the air-way from 4 to 3 or 2.

With one shutter plate, 4 air-ways can be changed to 3;

With two shutter plates, 4 air-ways can be changed to 2;

Changing to 1 way is not allowed.

Material: Foamed polyethylene + foamed urethane, color: Black

Item	Shutter plate	Shutter plate	
Quantity	2	1	
Shape			

Detailed installation information should be referred to its Installation Manual.

9-3. High efficiency filter element

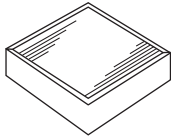

Life span: 2,500 hr (Dust concentration 0.15mg/m³); Colorimetric method 65% (JIS 11 class); No re-production.
 * The actual dust situation affects the filter life span, which should be considered at the applying site.
 Material: Electrostatic polyolefin fiber
 High efficiency filter element PAC-SH59KF-E should be used together with the Multi-function casement PAC-SJ41TM-E. When using PAC-SH59KF-E, switching on SW21-5 of the Indoor unit address board is needed. Details should be referred to its Installation Manual.

Quantity	1	
Shape		

Detailed installation information is referred in its Installation Manual.

9-4. Multi-function casement

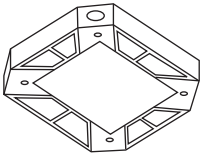
Multi-function casement is used for High efficiency filter element and/or fresh air intake from outdoor.
 It should be used with High efficiency filter element PAC-SH59KF-E (Colorimetric method 65%).
 Fresh air intake on the Multi-function casement is possible from any 2 or less corners among the 4 ones.
 But duct and flange on the casement should be prepare locally.

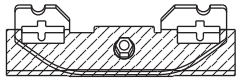
Item	Multi-functional casement	Screw with washer (black)	Screw	Grille securing bracket
Quantity	1	4	8	4
Shape		M5 × 0.8 × 25 	M5 × 0.8 × 12 	With insulator 

Detailed installation information should be referred to its Installation Manual.

9-5. 3D i-see Sensor corner panel

3D i-see Sensor provides comfortable space as it detects the floor temperature to prevent spotty temperature.
 And that enables the unit to save energy.
 Attention
 Make sure that there are no gaps between the unit and the grille, and the grille and ceiling.
 * It may cause dew dripping.

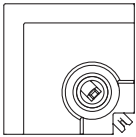
Item	3D i-see Sensor corner panel	
Quantity	1	
Shape		



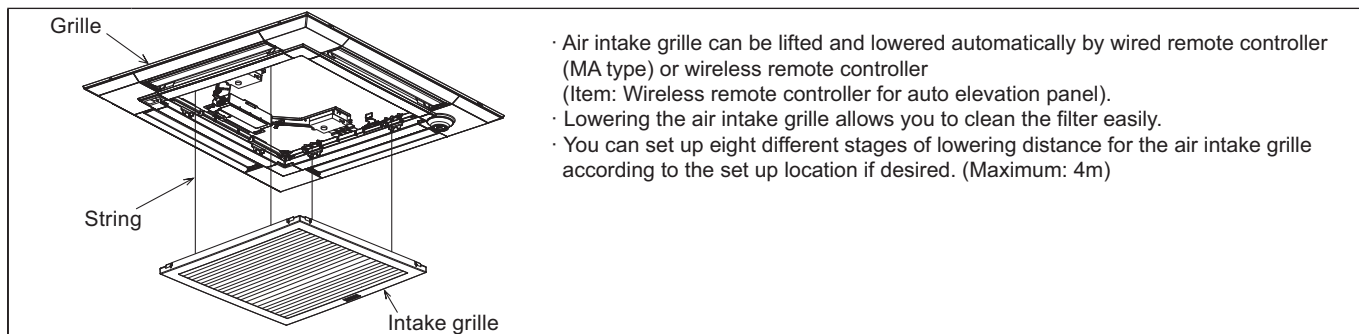

Detailed installation information should be referred to its Installation Manual.

9-6. Auto elevation panel

PLFY-M-VEIM6-E

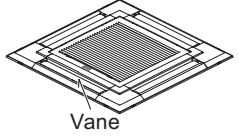
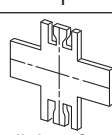
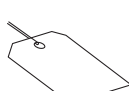

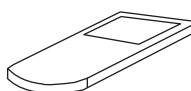
- Air intake grille can be lifted and lowered automatically by wired remote controller (MA type) or wireless remote controller (Item: Wireless remote controller for auto elevation panel).
- Lowering the air intake grille allows you to clean the filter easily.
- You can set up eight different stages of lowering distance for the air intake grille according to the set up location if desired. (Maximum: 4m)

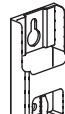
Item	Grille	Installation gauge	Tag	Screw
Quantity	1	1	1	2
Shape	 Vane	 (Used split into four pieces)		 4 × 16
Item	Wireless remote controller for auto elevation panel	Battery	Remote controller holder	
Quantity	1	1	1	
Shape		 Lithium battery CR2025 3V		

Grille with 3D i-see Sensor

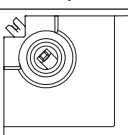
Item	Screw	3D i-see Sensor corner panel
Quantity	1	1
Shape	 4 × 16	

Detailed installation information should be referred to its Installation Manual.

9-7. Wireless signal receiver

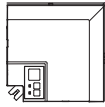

Wireless signal receiver PAR-SE9FA-E is necessary for using wireless remote controller		
Item	Wireless signal receiver	
Quantity	1	
Shape		

Detailed installation information should be referred to its Installation Manual.

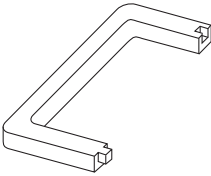
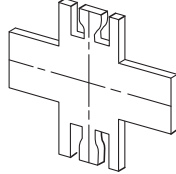
9-8. Space panel

Decorative cover for the installation when the ceiling height is low.		
Item	Space panel	Gauge for installation
Quantity	2	1
Shape		(Split this into four pieces) 

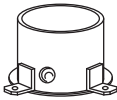
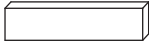
9-9. Duct flange for fresh air intake

Part to attach a duct to take in fresh air from outdoors.			
Item	Duct flange	Insulator	Screws (M4 x 10)
Quantity	1	1	3
Shape			

9-10. V blocking filter

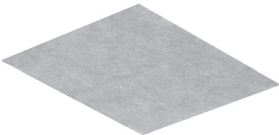
V Blocking Filter with antiviral effect inhibits 99% of adhered virus, and other harmful substances, such as bacteria, mold and allergen. Two-layered filter with non-woven fabric and electrostatic filter can effectively capture and remove small particles from the air in your room.		
Quantity	1	
Shape		

Detailed installation information is referred to its Installation Manual.

PLFY-M-VEIM6-E

9-11. 3D Total flow unit

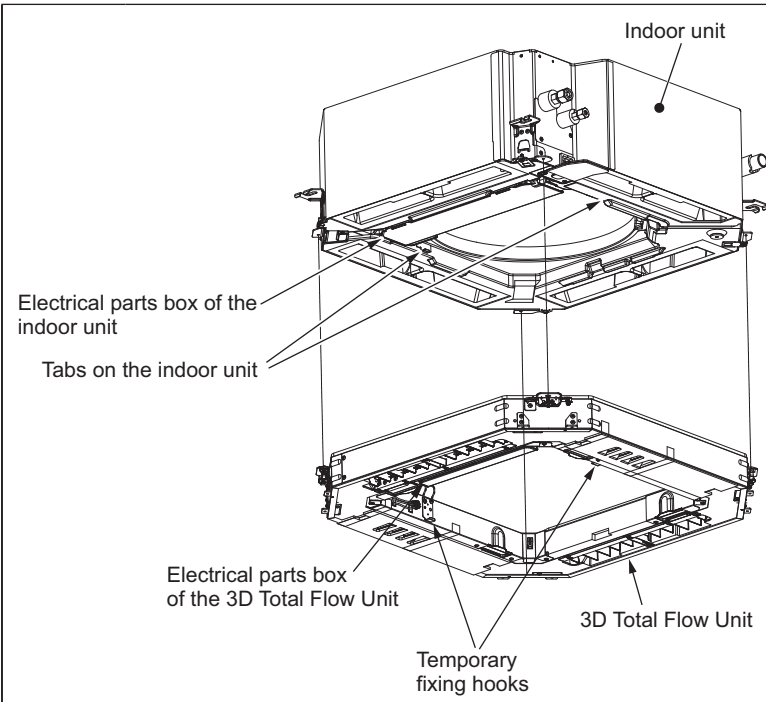

3D Total Flow is an innovative function. Our original 3D i-see sensor detects the temperature of the floor, and then the newly installed 3D Total Flow unit automatically controls the airflow in the left/right directions in a smart manner.

*3D Total Flow unit (PLP-U160ELR-E) cannot be used with Plasma Quad Connect (PAC-SK51FT-E), Insulation kit (PAC-SK36HK-E), Shutter Plate (PAC-SJ37SP-E), Multi functional casement (PAC-SJ41TM-E) and High-efficiency filter element (PAC-SH59KF-E).
*PAR-41MAA is required for each setting.

Item	3D Total Flow Unit	Screw	Mounting bracket for the grille	Rectifier piece
Quantity	1	8	4	1
Shape		M5×12 		
Item	Screw	Corner panel insulator		
Quantity	1	1		
Shape	ST4×10 	 Note: One sheet consists of 8 insulators.		

9-12. Plasma Quad Connect

PAC-SK51FT-E connects to CN105 on the indoor unit. When using an additional optional part, connect it to CN105 of PAC-SK51FT-E.

Item	Plasma Quad Connect	Screw with washer (black)	Screw	Grille securing bracket
Quantity	1	4	8	4
Shape		M5 × 0.8 × 25 	M5 × 0.8 × 12 	With insulator

Detailed installation information should be referred to its Installation Manual.

⚠ Warning

- Do not use refrigerant other than the type indicated in the manuals provided with the unit and on the nameplate.
 - Doing so may cause the unit or pipes to burst, or result in explosion or fire during use, repair, or at the time of disposal of the unit.
 - It may also be in violation of applicable laws.
 - MITSUBISHI ELECTRIC CORPORATION cannot be held responsible for malfunctions or accidents resulting from the use of the wrong type of refrigerant.
- Our air conditioning equipment and heat pumps contain a fluorinated greenhouse gas, R32 or R410A.

MITSUBISHI ELECTRIC CORPORATION

www.MitsubishiElectric.com