

AIR CONDITIONING SYSTEMS

# CITY MULTI



## DATA BOOK

MODEL

---

INDOOR UNIT

**PLFY-MS15-50VFM-E**



**PLFY-MS-VFM-E**

|   |        |
|---|--------|
| 1. SPECIFICATIONS .....                               | 2 - 20 |
| 2. EXTERNAL DIMENSIONS .....                          | 2 - 22 |
| 3. CENTER OF GRAVITY .....                            | 2 - 23 |
| 4. ELECTRICAL WIRING DIAGRAMS .....                   | 2 - 24 |
| 5. SOUND LEVELS .....                                 | 2 - 25 |
| 5-1. Sound levels .....                               | 2 - 25 |
| 5-2. NC curves .....                                  | 2 - 25 |
| 6. TEMPERATURE/AIRFLOW DISTRIBUTIONS .....            | 2 - 26 |
| 6-1. Temperature distributions .....                  | 2 - 26 |
| 6-2. Airflow distributions .....                      | 2 - 27 |
| 7. ELECTRICAL CHARACTERISTICS .....                   | 2 - 28 |
| 8. OPTIONAL PARTS .....                               | 2 - 29 |
| 8-1. Optional parts line up for the Indoor unit ..... | 2 - 29 |
| 8-2. 3D i-see Sensor corner panel .....               | 2 - 29 |
| 8-3. Wireless signal receiver .....                   | 2 - 29 |

# 1. SPECIFICATIONS

Ceiling cassette (4-way flow type)

| Model  |  |   | PLFY-MS15VFM-E   | PLFY-MS20VFM-E   | PLFY-MS25VFM-E   |   |  |  |
|--|--|---|--|--|--|---|--|--|
| Power source   |  |   | 1-phase 220-230-240V 50Hz/220V 60Hz  |  |  |   |  |  |
| Cooling capacity<br>(Nominal)  | *1   | kW  | 1.7  | 2.2  | 2.8  |   |  |  |
|  |  | BTU / h   | 5,800  | 7,500  | 9,600  |   |  |  |
|  | Power input  | kW  | 0.02   | 0.02   | 0.02   |   |  |  |
|  |  | A   | 0.21   | 0.22   | 0.23   |   |  |  |
| Heating capacity<br>(Nominal)  | *2   | kW  | 1.9  | 2.5  | 3.2  |   |  |  |
|  |  | BTU / h   | 6,500  | 8,500  | 10,900   |   |  |  |
|  | Power input  | kW  | 0.02   | 0.02   | 0.02   |   |  |  |
|  |  | A   | 0.16   | 0.17   | 0.18   |   |  |  |
| External finish  |  |   | Galvanized steel sheet   |  |  |   |  |  |
| External dimension H x W x D   |  | mm  | 208 x 570 x 570  | 208 x 570 x 570  | 208 x 570 x 570  |   |  |  |
|  |  | in.   | 8-1/4 x 22-1/2 x 22-1/2  | 8-1/4 x 22-1/2 x 22-1/2  | 8-1/4 x 22-1/2 x 22-1/2  |   |  |  |
| Net weight   |  | kg (lbs)  | 13 (29)  | 13 (29)  | 13 (29)  |   |  |  |
| Decoration panel   | Model  |   | SLP-2FA(L)(E)  | SLP-2FA(L)(E)  | SLP-2FA(L)(E)  |   |  |  |
|  | External finish  |   | MUNSELL (1.0Y 9.2/0.2)   |  |  |   |  |  |
|  | Dimension  | mm  | 10 x 625 x 625   | 10 x 625 x 625   | 10 x 625 x 625   |   |  |  |
|  | H x W x D  | in.   | 3/8 x 24-5/8 x 24-5/8  | 3/8 x 24-5/8 x 24-5/8  | 3/8 x 24-5/8 x 24-5/8  |   |  |  |
|  | Net Weight   | kg (lbs)  | 3 (7)  | 3 (7)  | 3 (7)  |   |  |  |
| Heat exchanger   |  |   | Cross fin (Aluminum fin and copper tube)   |  |  |   |  |  |
| FAN  | Type x Quantity  |   | Turbo fan x 1  |  |  |   |  |  |
|  | External static press.   |   | 0Pa (0mmH <sub>2</sub> O)  | 0Pa (0mmH <sub>2</sub> O)  | 0Pa (0mmH <sub>2</sub> O)  |   |  |  |
|  | Motor type   |   | DC motor   |  |  |   |  |  |
|  | Motor output   | kW  | 0.05   | 0.05   | 0.05   |   |  |  |
|  | Driving mechanism  |   | Direct-driven  |  |  |   |  |  |
|  | Airflow rate   |   |  | (Low-Mid-High)   | (Low-Mid-High)   | (Low-Mid-High)  |  |  |
|  |  | m <sup>3</sup> / min  |  | 6.5-7.5-8.0  | 6.5-7.5-8.5  | 6.5-8.0-9.0   |  |  |
| L / s  |  |   | 108-125-133  | 108-125-142  | 108-133-150  |   |  |  |
|  | cfm  |   | 230-265-282  | 230-265-300  | 230-282-318  |   |  |  |
| Sound pressure level<br>(measured in anechoic room)  |  | dB <A>  | (Low-Mid-High)<br>26-28-30   | (Low-Mid-High)<br>26-29-31   | (Low-Mid-High)<br>26-30-33   |   |  |  |
| Insulation material  |  |   | PS   |  |  |   |  |  |
| Air filter   |  |   | PP honeycomb fabric (long life type)   |  |  |   |  |  |
| Protection device  |  |   | Fuse   |  |  |   |  |  |
| Refrigerant control device   |  |   | LEV  |  |  |   |  |  |
| Connectable outdoor unit   |  |   | R32 CITY MULTI   |  |  |   |  |  |
| Diameter of<br>refrigerant pipe  | Liquid   | mm (in.)  | ø6.35 (ø1/4) Flare   | ø6.35 (ø1/4) Flare   | ø6.35 (ø1/4) Flare   |   |  |  |
|  | Gas  | mm (in.)  | ø12.7 (ø1/2) Flare   | ø12.7 (ø1/2) Flare   | ø12.7 (ø1/2) Flare   |   |  |  |
| Field drain pipe size  |  | mm (in.)  | O.D. 32 (1-1/4) (PVC pipe VP-25 connectable)   |  |  |   |  |  |
| Standard attachment  |  |   | Installation manual, Instruction book  |  |  |   |  |  |
| Remark   | Optional parts   |   |  |  |  |   |  |  |
|  | Decoration panel   |   | SLP-2FA/SLP-2FAE/SLP-2FAL/SLP-2FALE/SLP-2FALM2/SLP-2FALME2   |  |  |   |  |  |
|  | Plasma Quad Connect  |   | SLP-2FAP/SLP-2FALP/SLP-2FALMP2   |  |  |   |  |  |
|  |  |   | *PLFY-MS-VFM-E should be used together with Decoration panel.  |  |  |   |  |  |
| Installation   |  | Details on foundation work, duct work, insulation work, electrical wiring, power source switch, and other items shall be referred to the Installation Manual. |  |  |  |   |  |  |
| <b>Note :</b> <table border="0" style="width: 100%;"> <tr> <td style="width: 33%; vertical-align: top;">                     *1 Nominal cooling condition<br/>                     Indoor : 27°CDB/19°CWB (81°FDB/66°FWB)<br/>                     Outdoor : 35°CDB (95°FDB)<br/>                     Pipe length : 7.5 m (24-9/16 ft)<br/>                     Level difference : 0 m (0 ft)                 </td> <td style="width: 33%; vertical-align: top;">                     *2 Nominal heating condition<br/>                     20°CDB (68°FDB)<br/>                     7°CDB/6°CWB (45°FDB/43°FWB)<br/>                     7.5 m (24-9/16 ft)<br/>                     0 m (0 ft)                 </td> <td style="width: 33%; vertical-align: top;">                     Unit converter<br/>                     BTU/h = kW x 3,412<br/>                     cfm = m<sup>3</sup>/min x 35.31<br/>                     lbs = kg / 0.4536                 </td> </tr> </table> |  |   | *1 Nominal cooling condition<br>Indoor : 27°CDB/19°CWB (81°FDB/66°FWB)<br>Outdoor : 35°CDB (95°FDB)<br>Pipe length : 7.5 m (24-9/16 ft)<br>Level difference : 0 m (0 ft) | *2 Nominal heating condition<br>20°CDB (68°FDB)<br>7°CDB/6°CWB (45°FDB/43°FWB)<br>7.5 m (24-9/16 ft)<br>0 m (0 ft) | Unit converter<br>BTU/h = kW x 3,412<br>cfm = m <sup>3</sup> /min x 35.31<br>lbs = kg / 0.4536 | *Above specification data is subject to rounding variation. |  |  |
| *1 Nominal cooling condition<br>Indoor : 27°CDB/19°CWB (81°FDB/66°FWB)<br>Outdoor : 35°CDB (95°FDB)<br>Pipe length : 7.5 m (24-9/16 ft)<br>Level difference : 0 m (0 ft)   | *2 Nominal heating condition<br>20°CDB (68°FDB)<br>7°CDB/6°CWB (45°FDB/43°FWB)<br>7.5 m (24-9/16 ft)<br>0 m (0 ft) | Unit converter<br>BTU/h = kW x 3,412<br>cfm = m <sup>3</sup> /min x 35.31<br>lbs = kg / 0.4536  |  |  |  |   |  |  |
| * Nominal conditions *1, *2 are subject to JIS B8615-1.<br>* Due to continuing improvement, above specification may be subject to change without notice.   |  |   |  |  |  |   |  |  |

PLFY-MS-VFM-E

# 1. SPECIFICATIONS

Ceiling cassette (4-way flow type)

| Model  |                        |   | PLFY-MS32VFM-E   | PLFY-MS40VFM-E             | PLFY-MS50VFM-E   |
|--|------------------------|---|--|----------------------------|--|
| Power source   |                        |   | 1-phase 220-230-240V 50Hz/220V 60Hz  |                            |  |
| Cooling capacity<br>(Nominal)  | *1                     | kW  | 3.6  | 4.5                        | 5.6  |
|  | *1                     | BTU / h   | 12,300   | 15,400                     | 19,100   |
|  | Power input            | kW  | 0.02   | 0.03                       | 0.04   |
|  | Current input          | A   | 0.24   | 0.28                       | 0.40   |
| Heating capacity<br>(Nominal )   | *2                     | kW  | 4.0  | 5.0                        | 6.3  |
|  | *2                     | BTU / h   | 13,600   | 17,100                     | 21,500   |
|  | Power input            | kW  | 0.02   | 0.03                       | 0.04   |
|  | Current input          | A   | 0.19   | 0.23                       | 0.35   |
| External finish  |                        |   | Galvanized steel sheet   |                            |  |
| External dimension H x W x D   |                        | mm  | 208 x 570 x 570  | 208 x 570 x 570            | 208 x 570 x 570  |
|  |                        | in.   | 8-1/4 x 22-1/2 x 22-1/2  | 8-1/4 x 22-1/2 x 22-1/2    | 8-1/4 x 22-1/2 x 22-1/2  |
| Net weight   |                        | kg (lbs)  | 14 (31)  | 14 (31)                    | 14 (31)  |
| Decoration panel   | Model                  |   | SLP-2FA(L)(E)  | SLP-2FA(L)(E)              | SLP-2FA(L)(E)  |
|  | External finish        |   | MUNSELL (1.0Y 9.2/0.2)   |                            |  |
|  | Dimension              | mm  | 10 x 625 x 625   | 10 x 625 x 625             | 10 x 625 x 625   |
|  | H x W x D              | in.   | 3/8 x 24-5/8 x 24-5/8  | 3/8 x 24-5/8 x 24-5/8      | 3/8 x 24-5/8 x 24-5/8  |
|  | Net Weight             | kg (lbs)  | 3 (7)  | 3 (7)                      | 3 (7)  |
| Heat exchanger   |                        |   | Cross fin (Aluminum fin and copper tube)   |                            |  |
| FAN  | Type x Quantity        |   | Turbo fan x 1  |                            |  |
|  | External static press. |   | 0Pa (0mmH <sub>2</sub> O)  | 0Pa (0mmH <sub>2</sub> O)  | 0Pa (0mmH <sub>2</sub> O)  |
|  | Motor type             |   | DC motor   |                            |  |
|  | Motor output           | kW  | 0.05   | 0.05                       | 0.05   |
|  | Driving mechanism      |   | Direct-driven  |                            |  |
|  | Airflow rate           |   | (Low-Mid-High)   | (Low-Mid-High)             | (Low-Mid-High)   |
|  |                        |   | m <sup>3</sup> / min   | 7.0-8.0-9.5                | 7.5-9.0-11.0   |
| L / s  |                        |   | 117-133-158  | 125-150-183                | 150-183-217  |
|  | cfm                    | 247-282-335   | 265-318-388  | 318-388-459                |  |
| Sound pressure level<br>(measured in anechoic room)  |                        | dB <A>  | (Low-Mid-High)<br>26-30-34   | (Low-Mid-High)<br>28-33-39 | (Low-Mid-High)<br>33-39-43   |
| Insulation material  |                        |   | PS   |                            |  |
| Air filter   |                        |   | PP honeycomb fabric (long life type)   |                            |  |
| Protection device  |                        |   | Fuse   |                            |  |
| Refrigerant control device   |                        |   | LEV  |                            |  |
| Connectable outdoor unit   |                        |   | R32 CITY MULTI   |                            |  |
| Diameter of<br>refrigerant pipe  | Liquid                 | mm (in.)  | ø6.35 (ø1/4) Flare   | ø6.35 (ø1/4) Flare         | ø6.35 (ø1/4) Flare   |
|  | Gas                    | mm (in.)  | ø12.7 (ø1/2) Flare   | ø12.7 (ø1/2) Flare         | ø12.7 (ø1/2) Flare   |
| Field drain pipe size  |                        | mm (in.)  | O.D. 32 (1-1/4) (PVC pipe VP-25 connectable)   |                            |  |
| Standard attachment  |                        |   | Installation manual, Instruction book  |                            |  |
| Remark   | Optional parts         |   |  |                            |  |
|  | Decoration panel       |   | SLP-2FA/SLP-2FAE/SLP-2FAL/SLP-2FALE/SLP-2FALM2/SLP-2FALME2   |                            |  |
|  | Plasma Quad Connect    |   | SLP-2FAP/SLP-2FALP/SLP-2FALMP2   |                            |  |
|  |                        |   | *PLFY-MS-VFM-E should be used together with Decoration panel.  |                            |  |
| Installation   |                        | Details on foundation work, duct work, insulation work, electrical wiring, power source switch, and other items shall be referred to the Installation Manual. |  |                            |  |
| <b>Note :</b>  |                        |   | *1 Nominal cooling condition<br>Indoor : 27°CDB/19°CWB (81°FDB/66°FWB)<br>Outdoor : 35°CDB (95°FDB)<br>Pipe length : 7.5 m (24-9/16 ft)<br>Level difference : 0 m (0 ft) |                            | *2 Nominal heating condition<br>20°CDB (68°FDB)<br>7°CDB/6°CWB (45°FDB/43°FWB)<br>7.5 m (24-9/16 ft)<br>0 m (0 ft) |
|  |                        |   |  |                            | Unit converter<br>BTU/h = kW x 3,412<br>cfm = m <sup>3</sup> /min x 35.31<br>lbs = kg / 0.4536                     |
| * Nominal conditions *1, *2 are subject to JIS B8615-1.<br>* Due to continuing improvement, above specification may be subject to change without notice. |                        |   |  |                            | *Above specification data is subject to rounding variation.  |

PLFY-MS-VFM-E



PLFY-MS15, 20, 25, 32, 40, 50VFM-E

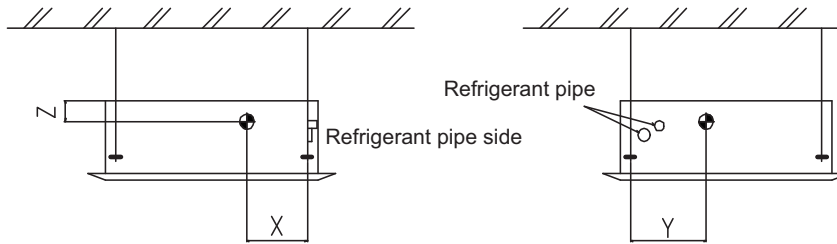

(mm)[in]

| Model name     | X             | Y            | Z            |
|----------------|---------------|--------------|--------------|
| PLFY-MS15VFM-E | 150 [5-29/32] | 260 [10-1/4] | 105 [4-5/32] |
| PLFY-MS20VFM-E | 150 [5-29/32] | 260 [10-1/4] | 105 [4-5/32] |
| PLFY-MS25VFM-E | 150 [5-29/32] | 260 [10-1/4] | 105 [4-5/32] |
| PLFY-MS32VFM-E | 150 [5-29/32] | 260 [10-1/4] | 105 [4-5/32] |
| PLFY-MS40VFM-E | 150 [5-29/32] | 260 [10-1/4] | 105 [4-5/32] |
| PLFY-MS50VFM-E | 150 [5-29/32] | 260 [10-1/4] | 105 [4-5/32] |

PLFY-MS15, 20, 25, 32, 40, 50VFM-E

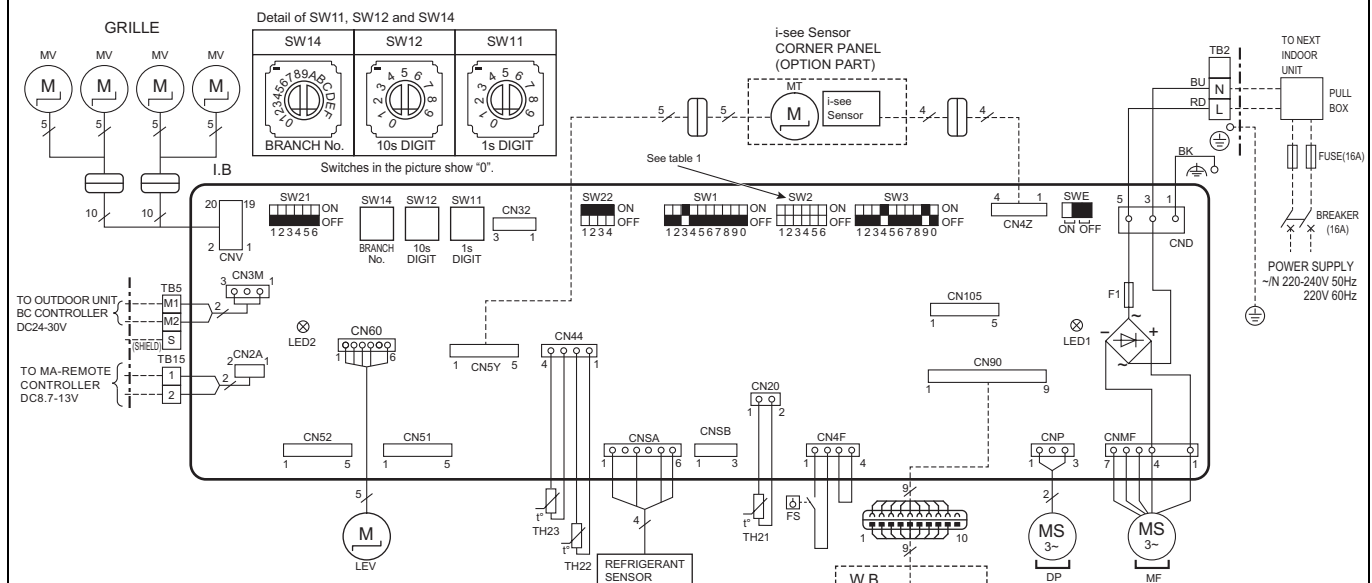

[LEGEND]

| SYMBOL         | NAME                                   |
|----------------|--|
| I.B            | INDOOR CONTROLLER BOARD                |
| CN32           | CONNECTOR REMOTE SWITCH                |
| CN51           | CENTRALLY CONTROL REMOTE INDICATION    |
| CN52           | IT TERMINAL                            |
| CN105          |  |
| F1             | FUSE(T6.3AL 250V)                      |
| LED1           | MAIN POWER SUPPLY (I.B)                |
| LED2           | POWER SUPPLY FOR MA-REMOTE CONTROLLER  |
| SW1            | SWITCH MODE SELECTION                  |
| SW2            | CAPACITY CODE                          |
| SW3            | MODE SELECTION                         |
| SW11           | ADDRESS SETTING 1s DIGIT               |
| SW12           | ADDRESS SETTING 10s DIGIT              |
| SW14           | BRANCH No.                             |
| SW21           | CEILING HEIGHT SELECTOR                |
| SW22           | PAIR NO. SETTING                       |
| SWE            | DRAIN PUMP(TEST MODE)                  |
| DP             | DRAIN PUMP                             |
| LEV            | LINEAR EXPANSION VALVE                 |
| MF             | FAN MOTOR                              |
| MV             | VANE MOTOR                             |
| FS             | DRAIN FLOAT SWITCH                     |
| TB2            | TERMINAL POWER SUPPLY                  |
| TB5            | BLOCK TRANSMISSION                     |
| TB15           | MA-REMOTE CONTROLLER                   |
| TH21           | THERMISTOR ROOM TEMP. DETECTION        |
| TH22           | PIPE TEMP. DETECTION / LIQUID          |
| TH23           | PIPE TEMP. DETECTION / GAS             |
| OPTIONAL PARTS |  |
| W.B            | PCB FOR WIRELESS REMOTE CONTROLLER     |
| BZ             | BUZZER                                 |
| LED1           | LED (OPERATION INDICATION : GREEN)     |
| LED2           | LED (PREPARATION FOR HEATING : ORANGE) |
| RU             | RECEIVING UNIT                         |
| SW1            | EMERGENCY OPERATION(HEAT)              |
| SW2            | EMERGENCY OPERATION(COOL)              |
| MT             | i-see Sensor MOTOR                     |

<Table 1> SW2 (CAPACITY CODE)

| MODELS | SW2           | MODELS | SW2           |
|--------|---------------|--------|---------------|
| 15     | ON OFF 123456 | 32     | ON OFF 123456 |
| 20     | ON OFF 123456 | 40     | ON OFF 123456 |
| 25     | ON OFF 123456 | 50     | ON OFF 123456 |

Notes:

- At servicing for outdoor unit, always follow the wiring diagram of outdoor unit.
- In case of using MA-Remote controller, please connect to TB15. (Remote controller wire is non-polar.)
- In case of using M-NET, please connect to TB5. (Transmission line is non-polar.)
- Symbol [S] of TB5 is the shield wire connection.
- Symbols used in wiring diagram are, [ ] : terminal block, [ ] : connector.
- The setting of the SW2 dip switches differs in the capacity. For the detail, see table 1.
- Make sure to turn off the indoor and the outdoor units before replacing indoor controller board.
- The black square (■) in the wiring diagram indicates a switch position.

5-1. Sound levels

PLFY-MS-VFM-E

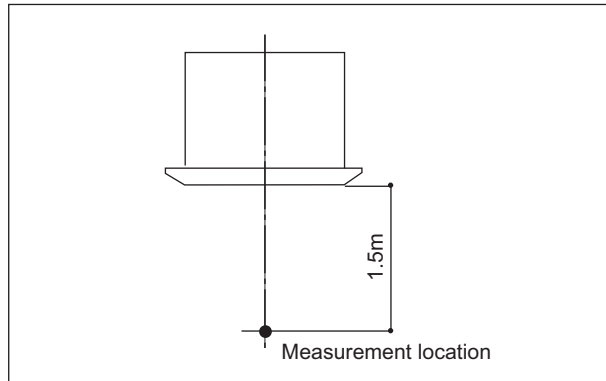

\* Measured in anechoic room.

Sound level at anechoic room : Low-Mid-High

|                | Sound level dB (A) |
|----------------|--------------------|
| PLFY-MS15VFM-E | 26-28-30           |
| PLFY-MS20VFM-E | 26-29-31           |
| PLFY-MS25VFM-E | 26-30-33           |
| PLFY-MS32VFM-E | 26-30-34           |
| PLFY-MS40VFM-E | 28-33-39           |
| PLFY-MS50VFM-E | 33-39-43           |

5-2. NC curves

PLFY-MS15VFM-E

External Static Pressure: 0Pa [0.00in.WG]  
Power Source: 220,230,240V, 50Hz/220V, 60Hz

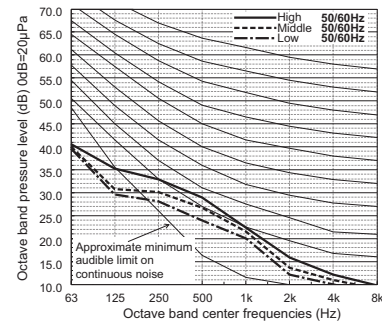

PLFY-MS20VFM-E

External Static Pressure: 0Pa [0.00in.WG]  
Power Source: 220,230,240V, 50Hz/220V, 60Hz

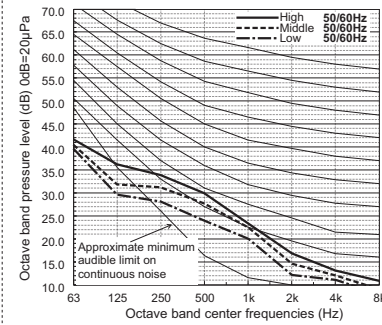

PLFY-MS25VFM-E

External Static Pressure: 0Pa [0.00in.WG]  
Power Source: 220,230,240V, 50Hz/220V, 60Hz

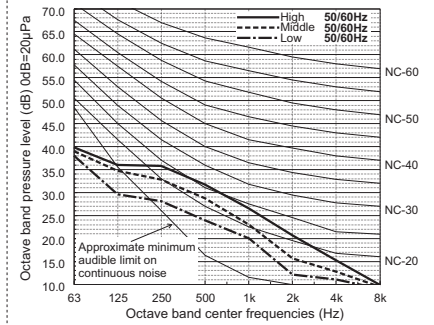

PLFY-MS32VFM-E

External Static Pressure: 0Pa [0.00in.WG]  
Power Source: 220,230,240V, 50Hz/220V, 60Hz

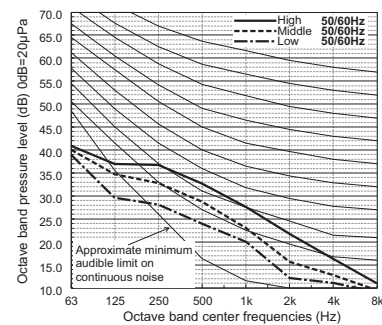

PLFY-MS40VFM-E

External Static Pressure: 0Pa [0.00in.WG]  
Power Source: 220,230,240V, 50Hz/220V, 60Hz

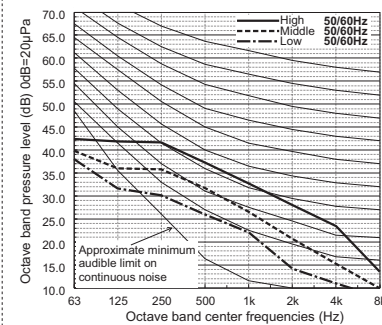

PLFY-MS50VFM-E

External Static Pressure: 0Pa [0.00in.WG]  
Power Source: 220,230,240V, 50Hz/220V, 60Hz

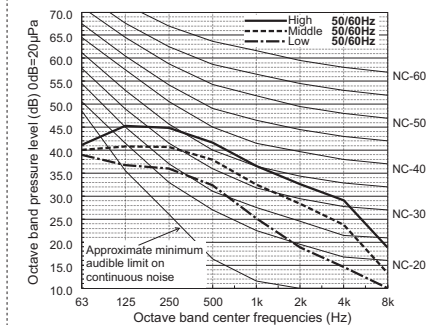



6-1. Temperature distributions

PLFY-MS15-50VFM-E

<Cooling mode>

Horizontal  
Ceiling height : 2.7m

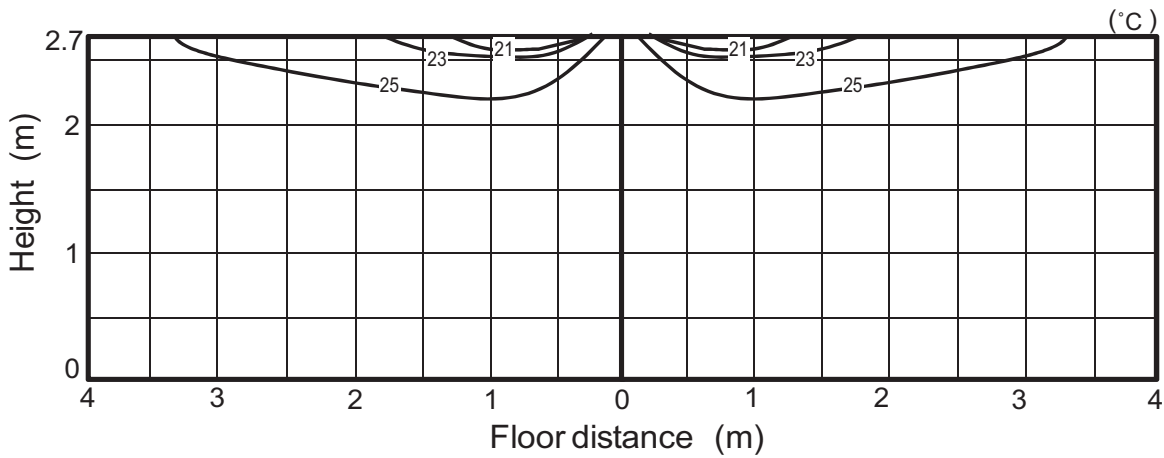

<Heating mode>

Downward  
Ceiling height : 2.7m

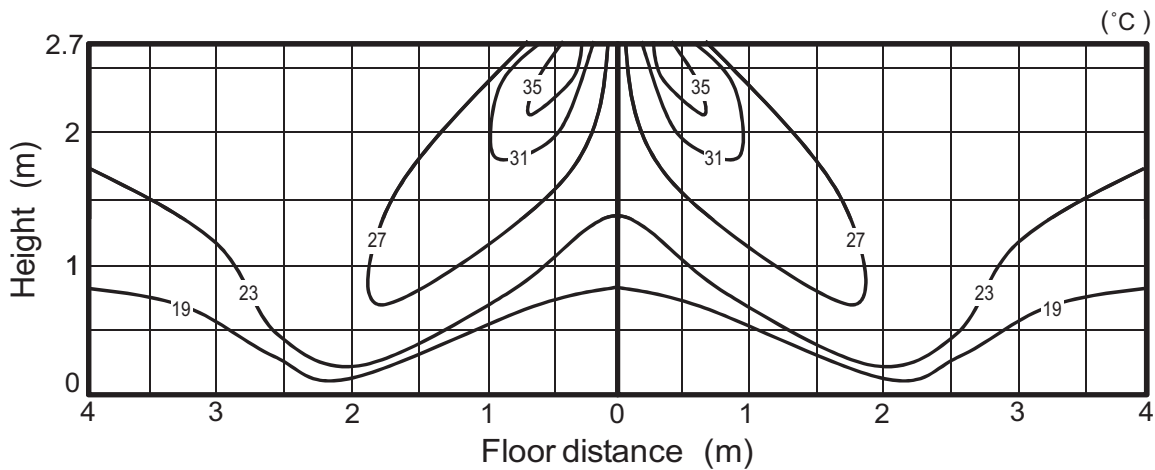

Note : These figures show typical temperature distributions in the conditions above. In the actual installation, they may differ from these figures under the influence of air temperature conditions, ceiling height, cooling/heating load, obstacles, etc.

PLFY-MS-VFM-E

6-2. Airflow distributions

PLFY-MS15-50VFM-E

<Cooling mode>

Horizontal

Ceiling height : 2.7m

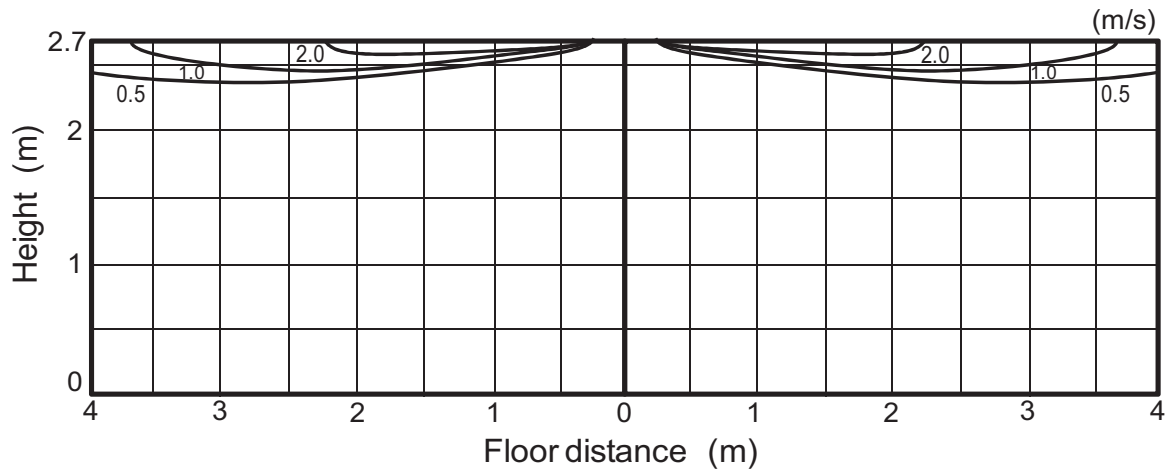

<Heating mode>

Downward

Ceiling height : 2.7m

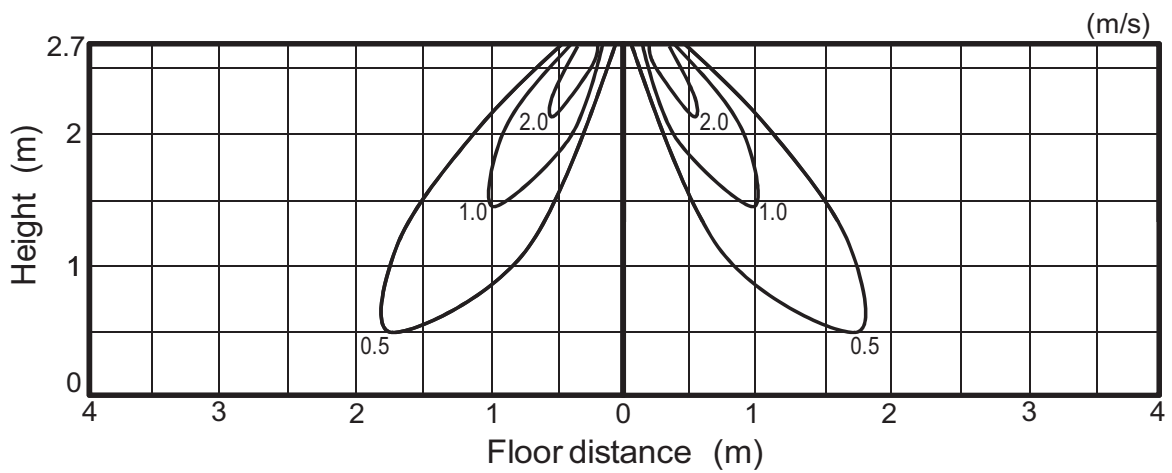

Note : These figures show typical airflow distributions in the conditions above. In the actual installation, they may differ from these figures under the influence of air temperature conditions, ceiling height, cooling/heating load, obstacles, etc.

## 7. ELECTRICAL CHARACTERISTICS

Ceiling cassette (4-way flow type)

Symbols: MCA (Max.Circuit Amps =1.25xFLA), FLA (Full Load Amps)  
IFM (Indoor Fan Motor), Output (Fan motor rated output)

| Model name     | Power supply               |                          |        | IFM         |        |
|----------------|----------------------------|--------------------------|--------|-------------|--------|
|                | Volts/Hz                   | Range +-10%              | MCA(A) | Output (kW) | FLA(A) |
| PLFY-MS15VFM-E | 220-240V/50Hz<br>220V/60Hz | Max.: 264V<br>Min.: 198V | 0.27   | 0.05        | 0.21   |
| PLFY-MS20VFM-E |                            |                          | 0.28   | 0.05        | 0.22   |
| PLFY-MS25VFM-E |                            |                          | 0.29   | 0.05        | 0.23   |
| PLFY-MS32VFM-E |                            |                          | 0.03   | 0.05        | 0.24   |
| PLFY-MS40VFM-E |                            |                          | 0.35   | 0.05        | 0.28   |
| PLFY-MS50VFM-E |                            |                          | 0.50   | 0.05        | 0.40   |



PLFY-MS-VFM-E

8-1. Optional parts line up for the Indoor unit

|               | Description                  | Model       |
|---------------|------------------------------|-------------|
| PLFY-MS-VFM-E | 3D i-see Sensor corner panel | PAC-SF1ME-E |
|               | Wireless signal receiver     | PAR-SF9FA-E |

8-2. 3D i-see Sensor corner panel

3D i-see Sensor provides comfortable space as it detects the floor temperature to prevent spotty temperature. And that enables the unit to save energy.  
 Attention  
 Make sure that there are no gaps between the unit and the grille, and the grille and ceiling.  
 \* It may cause dew dripping.

| Item     | 3D i-see Sensor corner panel  | Plastic fastener  |  |
|----------|---|---|--|
| Quantity | 1   | 2   |  |
| Shape    |  |  |  |

Detailed installation information should be referred to its Installation Manual.

8-3. Wireless signal receiver

Wireless signal receiver PAR-SF9FA-E is necessary for using wireless remote controller  
 PAR-SF9FA-E is a corner panel with the signal receiver for wireless remote controller.

| Item     | Wireless signal receiver  |  |
|----------|---|--|
| Quantity | 1   |  |
| Shape    |  |  |

Detailed installation information should be referred to its Installation Manual.



**⚠ Warning**

- Do not use refrigerant other than the type indicated in the manuals provided with the unit and on the nameplate.
  - Doing so may cause the unit or pipes to burst, or result in explosion or fire during use, repair, or at the time of disposal of the unit.
  - It may also be in violation of applicable laws.
  - MITSUBISHI ELECTRIC CORPORATION cannot be held responsible for malfunctions or accidents resulting from the use of the wrong type of refrigerant.
- Our air conditioning equipment and heat pumps contain a fluorinated greenhouse gas, R32.

**MITSUBISHI ELECTRIC CORPORATION**

[www.MitsubishiElectric.com](http://www.MitsubishiElectric.com)