

AIR CONDITIONING SYSTEMS

CITY MULTI



DATA BOOK

MODEL

INDOOR UNIT

PLFY-MS20-125VEM-E



PLFY-MS-VEM-E

1. SPECIFICATIONS	2 - 2
2. EXTERNAL DIMENSIONS	2 - 5
3. CENTER OF GRAVITY	2 - 6
4. ELECTRICAL WIRING DIAGRAMS	2 - 7
5. SOUND LEVELS	2 - 8
5-1. Sound levels	2 - 8
5-2. NC curves	2 - 8
6. TEMPERATURE/AIRFLOW DISTRIBUTIONS.....	2 - 9
6-1. Temperature distributions	2 - 9
6-2. Airflow distributions	2 - 11
7. ELECTRICAL CHARACTERISTICS	2 - 13
8. OPTIONAL PARTS.....	2 - 14
8-1. Optional parts line up for the Indoor unit.....	2 - 14
8-2. Air outlet shutter plate	2 - 14
8-3. High efficiency filter element.....	2 - 15
8-4. Multi-function casement.....	2 - 15
8-5. 3D i-see Sensor corner panel	2 - 15
8-6. Auto elevation panel	2 - 16
8-7. Wireless signal receiver	2 - 17
8-8. Space panel.....	2 - 17
8-9. Duct flange for fresh air intake	2 - 17
8-10.3D Total flow unit.....	2 - 18
8-11.Plasma Quad Connect	2 - 18

1. SPECIFICATIONS

Ceiling cassette (4-way flow type)

Model			PLFY-MS20VEM-E	PLFY-MS25VEM-E	PLFY-MS32VEM-E	PLFY-MS40VEM-E	
Power source			1-phase 220-240V 50Hz, 1-phase 220V 60Hz				
Cooling capacity (Nominal)	*1	kW	2.2	2.8	3.6	4.5	
		BTU / h	7,500	9,600	12,300	15,400	
	Power input	kW	0.03	0.03	0.03	0.03	
		Current input	A	0.31	0.31	0.32	0.32
Heating capacity (Nominal)	*2	kW	2.5	3.2	4.0	5.0	
		BTU / h	8,500	10,900	13,600	17,100	
	Power input	kW	0.03	0.03	0.03	0.03	
		Current input	A	0.24	0.24	0.25	0.25
External finish			Galvanized steel sheet				
External dimension H x W x D		mm	258 x 840 x 840				
		in.	10-3/16 x 33-3/32 x 33-3/32				
Net weight		kg (lbs)	19 (42)	19 (42)	19 (42)	19 (42)	
Decoration panel	Model		PLP-6EA	PLP-6EA	PLP-6EA	PLP-6EA	
	External finish		MUNSELL (1.0Y 9.2/0.2)				
	Dimension H x W x D	mm	40 x 950 x 950				
		in.	1-9/16 x 37-13/32 x 37-13/32				
	Net weight		kg (lbs)	5 (11)			
Heat exchanger			Cross fin (Aluminum fin and copper tube)				
FAN	Type x Quantity		Turbo fan x 1	Turbo fan x 1	Turbo fan x 1	Turbo fan x 1	
	External static press.	Pa	0	0	0	0	
		mmH ₂ O	0	0	0	0	
	Motor type		DC motor				
	Motor output		kW	0.050	0.050	0.050	0.050
	Driving mechanism		Direct-drive				
	Airflow rate		(Low-Mid2-Mid1-High)	(Low-Mid2-Mid1-High)	(Low-Mid2-Mid1-High)	(Low-Mid2-Mid1-High)	
			m ³ / min	12 - 13 - 14 - 15	12 - 13 - 14 - 15	13 - 14 - 15 - 16	13 - 14 - 15 - 17
L / s			200 - 217 - 233 - 250	200 - 217 - 233 - 250	217 - 233 - 250 - 267	217 - 233 - 250 - 283	
		cfm	424 - 459 - 494 - 530	424 - 459 - 494 - 530	459 - 494 - 530 - 565	459 - 494 - 530 - 600	
Sound pressure level (measured in anechoic room)		dB <A>	(Low-Mid2-Mid1-High) 24 - 26 - 27 - 29	(Low-Mid2-Mid1-High) 24 - 26 - 27 - 29	(Low-Mid2-Mid1-High) 26 - 27 - 29 - 31	(Low-Mid2-Mid1-High) 26 - 27 - 29 - 31	
Insulation material			PS				
Air filter			PP honeycomb				
Protection device			Fuse				
Refrigerant control device			LEV				
Connectable outdoor unit			R32 CITY MULTI				
Diameter of refrigerant pipe	Liquid	mm (in.)	ø6.35 (ø1/4) Flare	ø6.35 (ø1/4) Flare	ø6.35 (ø1/4) Flare	ø6.35 (ø1/4) Flare	
	Gas	mm (in.)	ø12.7 (ø1/2) Flare	ø12.7 (ø1/2) Flare	ø12.7 (ø1/2) Flare	ø12.7 (ø1/2) Flare	
Field drain pipe size		mm (in.)	O.D. ø32 (1-1/4) (VP-25)				
Standard attachment		Document Accessory	Installation Manual, Instruction Book				
Remark			Optional parts				
Decoration panel **1			PLP-6EA	PLP-6EA	PLP-6EA	PLP-6EA	
Signal receiver panel **1			PLP-6EAL	PLP-6EAL	PLP-6EAL	PLP-6EAL	
3D i-see Sensor panel **1			PLP-6EAE	PLP-6EAE	PLP-6EAE	PLP-6EAE	
3D i-see Sensor and signal receiver panel **1			PLP-6EALE	PLP-6EALE	PLP-6EALE	PLP-6EALE	
Auto elevation and signal receiver panel **1			PLP-6EAJ	PLP-6EAJ	PLP-6EAJ	PLP-6EAJ	
Auto elevation, 3D i-see Sensor and signal receiver panel **1			PLP-6EAJE	PLP-6EAJE	PLP-6EAJE	PLP-6EAJE	
With wireless remote controller and signal receiver panel **1			PLP-6EALM2	PLP-6EALM2	PLP-6EALM2	PLP-6EALM2	
With wireless remote controller, signal receiver and 3D i-see Sensor panel **1			PLP-6EALME2	PLP-6EALME2	PLP-6EALME2	PLP-6EALME2	
Black panel **1			PLP-6EAB	PLP-6EAB	PLP-6EAB	PLP-6EAB	
Air outlet shutter plate			PAC-SJ37SP-E	PAC-SJ37SP-E	PAC-SJ37SP-E	PAC-SJ37SP-E	
High efficiency filter element **2			PAC-SH59KF-E	PAC-SH59KF-E	PAC-SH59KF-E	PAC-SH59KF-E	
Multi-function casement			PAC-SJ41TM-E	PAC-SJ41TM-E	PAC-SJ41TM-E	PAC-SJ41TM-E	
3D i-see Sensor corner panel			PAC-SE1ME-E	PAC-SE1ME-E	PAC-SE1ME-E	PAC-SE1ME-E	
3D total flow unit			PLP-U160ELR-E	PLP-U160ELR-E	PLP-U160ELR-E	PLP-U160ELR-E	
Wireless signal receiver			PAR-SE9FA-E	PAR-SE9FA-E	PAR-SE9FA-E	PAR-SE9FA-E	
Space panel			PAC-SJ65AS-E	PAC-SJ65AS-E	PAC-SJ65AS-E	PAC-SJ65AS-E	
Duct flange for fresh air intake			PAC-SH65OF-E	PAC-SH65OF-E	PAC-SH65OF-E	PAC-SH65OF-E	
Plasma Quad Connect			PAC-SK51FT-E	PAC-SK51FT-E	PAC-SK51FT-E	PAC-SK51FT-E	
			**1.PLFY-MS-VEM-E should be used together with PLP-6EA/EAL/EAE/EALE/EAJ/EAJE/EALM2/EALME2/EAB.				
			**2.PAC-SJ41TM-E is necessary to use with filter PAC-SH59KF-E.				
Installation			Details on foundation work, duct work, insulation work, electrical wiring, power source switch, and other items shall be referred to the Installation Manual.				
Note :			*1 Nominal cooling condition		*2 Nominal heating condition		
Indoor :			27°CDB/19°CWB (81°FDB/66°FWB)		20°CDB (68°FDB)		
Outdoor :			35°CDB (95°FDB)		7°CDB/6°CWB (45°FDB/43°FWB)		
Pipe length :			7.5 m (24-9/16 ft)		7.5 m (24-9/16 ft)		
Level difference :			0 m (0 ft)		0 m (0 ft)		
			* Nominal conditions *1, *2 are subject to JIS B8615-1.				
			* Due to continuing improvement, above specification may be subject to change without notice.				
					Unit converter		
					BTU/h = kW x 3.412		
					cfm = m ³ /min x 35.31		
					lbs = kg / 0.4536		
					*Above specification data is subject to rounding variation.		

1. SPECIFICATIONS

Ceiling cassette (4-way flow type)

Model			PLFY-MS50VEM-E	PLFY-MS63VEM-E	PLFY-MS80VEM-E	PLFY-MS100VEM-E	
Power source			1-phase 220-240V 50Hz, 1-phase 220V 60Hz				
Cooling capacity (Nominal)	*1	kW	5.6	7.1	9.0	11.2	
		BTU / h	19,100	24,200	30,700	38,200	
	*1	Power input kW	0.03	0.03	0.05	0.07	
		Current input A	0.32	0.36	0.50	0.67	
Heating capacity (Nominal)	*2	kW	6.3	8.0	10.0	12.5	
		BTU / h	21,500	27,300	34,100	42,700	
	*2	Power input kW	0.03	0.03	0.05	0.07	
		Current input A	0.25	0.29	0.43	0.60	
External finish			Galvanized steel sheet				
External dimension H x W x D		mm	258 x 840 x 840			298 x 840 x 840	
		in.	10-3/16 x 33-3/32 x 33-3/32			11-3/4 x 33-3/32 x 33-3/32	
Net weight		kg (lbs)	19 (42)	21 (46)	21 (46)	24 (53)	
Decoration panel	Model		PLP-6EA	PLP-6EA	PLP-6EA	PLP-6EA	
	External finish		MUNSELL (1.0Y 9.2/0.2)				
	Dimension	mm	40 x 950 x 950				
		in.	1-9/16 x 37-13/32 x 37-13/32				
	Net weight		5 (11)				
Heat exchanger			Cross fin (Aluminum fin and copper tube)				
FAN	Type x Quantity		Turbo fan x 1	Turbo fan x 1	Turbo fan x 1	Turbo fan x 1	
	External static press.	Pa	0	0	0	0	
		mmH ₂ O	0	0	0	0	
	Motor type		DC motor				
	Motor output	kW	0.050	0.050	0.050	0.120	
	Driving mechanism		Direct-drive				
	Airflow rate	(Low-Mid2-Mid1-High)		(Low-Mid2-Mid1-High)	(Low-Mid2-Mid1-High)	(Low-Mid2-Mid1-High)	(Low-Mid2-Mid1-High)
		m ³ / min	13 - 14 - 16 - 18	14 - 15 - 16 - 18	14 - 17 - 20 - 23	20 - 23 - 26 - 29	
		L / s	217 - 233 - 267 - 300	233 - 250 - 267 - 300	233 - 283 - 333 - 383	333 - 383 - 433 - 483	
		cfm	459 - 494 - 565 - 636	494 - 530 - 565 - 636	494 - 600 - 706 - 812	706 - 812 - 918 - 1024	
Sound pressure level (measured in anechoic room)		(Low-Mid2-Mid1-High)	(Low-Mid2-Mid1-High)	(Low-Mid2-Mid1-High)	(Low-Mid2-Mid1-High)		
		dB <A>	26 - 27 - 29 - 31	28 - 29 - 30 - 32	28 - 31 - 34 - 37	34 - 37 - 39 - 41	
Insulation material			PS				
Air filter			PP honeycomb				
Protection device			Fuse				
Refrigerant control device			LEV				
Connectable outdoor unit			R32 CITY MULTI				
Diameter of refrigerant pipe	Liquid	mm (in.)	ø6.35 (ø1/4) Flare	ø9.52 (ø3/8) Flare	ø9.52 (ø3/8) Flare	ø9.52 (ø3/8) Flare	
	Gas	mm (in.)	ø12.7 (ø1/2) Flare	ø15.88 (ø5/8) Flare	ø15.88 (ø5/8) Flare	ø15.88 (ø5/8) Flare	
Field drain pipe size		mm (in.)	O.D. ø32 (1-1/4) (VP-25)				
Standard attachment	Document Accessory		Installation Manual, Instruction Book				
Remark	Optional parts						
	Decoration panel **1		PLP-6EA	PLP-6EA	PLP-6EA	PLP-6EA	
	Signal receiver panel **1		PLP-6EAL	PLP-6EAL	PLP-6EAL	PLP-6EAL	
	3D i-see Sensor panel **1		PLP-6EAE	PLP-6EAE	PLP-6EAE	PLP-6EAE	
	3D i-see Sensor and signal receiver panel **1		PLP-6EALE	PLP-6EALE	PLP-6EALE	PLP-6EALE	
	Auto elevation and signal receiver panel **1		PLP-6EAJ	PLP-6EAJ	PLP-6EAJ	PLP-6EAJ	
	Auto elevation, 3D i-see Sensor and signal receiver panel **1		PLP-6EAJE	PLP-6EAJE	PLP-6EAJE	PLP-6EAJE	
	With wireless remote controller and signal receiver panel **1		PLP-6EALM2	PLP-6EALM2	PLP-6EALM2	PLP-6EALM2	
	With wireless remote controller, signal receiver and 3D i-see Sensor panel **1		PLP-6EALME2	PLP-6EALME2	PLP-6EALME2	PLP-6EALME2	
	Black panel **1		PLP-6EAB	PLP-6EAB	PLP-6EAB	PLP-6EAB	
	Air outlet shutter plate		PAC-SJ37SP-E	PAC-SJ37SP-E	PAC-SJ37SP-E	PAC-SJ37SP-E	
	High efficiency filter element **2		PAC-SH59KF-E	PAC-SH59KF-E	PAC-SH59KF-E	PAC-SH59KF-E	
	Multi-function casement		PAC-SJ41TM-E	PAC-SJ41TM-E	PAC-SJ41TM-E	PAC-SJ41TM-E	
	3D i-see Sensor corner panel		PAC-SE1ME-E	PAC-SE1ME-E	PAC-SE1ME-E	PAC-SE1ME-E	
	3D total flow unit		PLP-U160ELR-E	PLP-U160ELR-E	PLP-U160ELR-E	PLP-U160ELR-E	
	Wireless signal receiver		PAR-SE9FA-E	PAR-SE9FA-E	PAR-SE9FA-E	PAR-SE9FA-E	
	Space panel		PAC-SJ65AS-E	PAC-SJ65AS-E	PAC-SJ65AS-E	PAC-SJ65AS-E	
	Duct flange for fresh air intake		PAC-SH65OF-E	PAC-SH65OF-E	PAC-SH65OF-E	PAC-SH65OF-E	
	Plasma Quad Connect		PAC-SK51FT-E	PAC-SK51FT-E	PAC-SK51FT-E	PAC-SK51FT-E	
			**1.PLFY-MS-VEM-E should be used together with PLP-6EA/EAL/EAE/EALJ/EALJE/EALM2/EALME2/EAB.				
			**2.PAC-SJ41TM-E is necessary to use with filter PAC-SH59KF-E.				
	Installation		Details on foundation work, duct work, insulation work, electrical wiring, power source switch, and other items shall be referred to the Installation Manual.				
	Note :		*1 Nominal cooling condition	*2 Nominal heating condition		Unit converter	
	Indoor :		27°CDB/19°CWB (81°FDB/66°FWB)	20°CDB (68°FDB)		BTU/h = kW x 3,412	
	Outdoor :		35°CDB (95°FDB)	7°CDB/6°CWB (45°FDB/43°FWB)		cfm = m ³ /min x 35.31	
Pipe length :		7.5 m (24-9/16 ft)	7.5 m (24-9/16 ft)		lbs = kg / 0.4536		
Level difference :		0 m (0 ft)	0 m (0 ft)				
		* Nominal conditions *1, *2 are subject to JIS B8615-1.					
		* Due to continuing improvement, above specification may be subject to change without notice.					
						*Above specification data is subject to rounding variation.	

PLFY-MS-VEM-E

1. SPECIFICATIONS

Ceiling cassette (4-way flow type)

PLFY-MS-VEM-E

Model		PLFY-MS125VEM-E	
Power source		1-phase 220-240V 50Hz, 1-phase 220V 60Hz	
Cooling capacity (Nominal)	*1 kW	14.0	
	*1 BTU / h	47,800	
	Power input kW	0.11	
	Current input A	1.06	
Heating capacity (Nominal)	*2 kW	16.0	
	*2 BTU / h	54,600	
	Power input kW	0.11	
	Current input A	0.99	
External finish		Galvanized steel sheet	
External dimension H x W x D		mm	298 x 840 x 840
		in.	11-3/4 x 33-3/32 x 33-3/32
Net weight		kg (lbs)	24 (53)
Decoration panel	Model		PLP-6EA
	External finish		MUNSELL (1.0Y 9.2/0.2)
	Dimension H x W x D	mm	40 x 950 x 950
		in.	1-9/16 x 37-13/32 x 37-13/32
	Net weight	kg (lbs)	5 (11)
Heat exchanger		Cross fin (Aluminum fin and copper tube)	
FAN	Type x Quantity		Turbo fan x 1
	External static press.	Pa	0
		mmH ₂ O	0
	Motor type		DC motor
	Motor output	kW	0.120
	Driving mechanism		Direct-drive
	Airflow rate	(Low-Mid2-Mid1-High)	
m ³ / min		22 - 26 - 30 - 35	
L / s		367 - 433 - 500 - 583	
	cfm	777 - 918 - 1060 - 1236	
Sound pressure level (measured in anechoic room)		dB <A>	(Low-Mid2-Mid1-High) 35 - 39 - 42 - 45
Insulation material		PS	
Air filter		PP honeycomb	
Protection device		Fuse	
Refrigerant control device		LEV	
Connectable outdoor unit		R32 CITY MULTI	
Diameter of refrigerant pipe	Liquid	mm (in.)	ø9.52 (ø3/8) Flare
	Gas	mm (in.)	ø15.88 (ø5/8) Flare
Field drain pipe size		mm (in.)	O.D. ø32 (1-1/4) (VP-25)
Standard attachment	Document Accessory		Installation Manual, Instruction Book
Remark	Optional parts		
	Decoration panel **1		PLP-6EA
	Signal receiver panel **1		PLP-6EAL
	3D i-see Sensor panel **1		PLP-6EAE
	3D i-see Sensor and signal receiver panel **1		PLP-6EAL
	Auto elevation and signal receiver panel **1		PLP-6EAJ
	Auto elevation, 3D i-see Sensor and signal receiver panel **1		PLP-6EAJE
	With wireless remote controller and signal receiver panel **1		PLP-6EALM2
	With wireless remote controller, signal receiver and 3D i-see Sensor panel **1		PLP-6EALME2
	Black panel **1		PLP-6EAB
	Air outlet shutter plate		PAC-SJ37SP-E
	High efficiency filter element **2		PAC-SH59KF-E
	Multi-function casement		PAC-SJ41TM-E
	3D i-see Sensor corner panel		PAC-SE1ME-E
	3D total flow unit		PLP-U160ELR-E
	Wireless signal receiver		PAR-SE9FA-E
	Space panel		PAC-SJ65AS-E
	Duct flange for fresh air intake		PAC-SH65OF-E
	Plasma Quad Connect		PAC-SK51FT-E
			**1.PLFY-MS-VEM-E should be used together with PLP-6EA/EAL/EAE/EAJ/EAJE/EALM2/EALME2/EAB. **2.PAC-SJ41TM-E is necessary to use with filter PAC-SH59KF-E.
Installation		Details on foundation work, duct work, insulation work, electrical wiring, power source switch, and other items shall be referred to the Installation Manual.	
Note :	*1 Nominal cooling condition		*2 Nominal heating condition
	Indoor : 27°CDB/19°CWB (81°FDB/66°FWB)		20°CDB (68°FDB)
	Outdoor : 35°CDB (95°FDB)		7°CDB/6°CWB (45°FDB/43°FWB)
	Pipe length : 7.5 m (24-9/16 ft)		7.5 m (24-9/16 ft)
Level difference : 0 m (0 ft)		0 m (0 ft)	
* Nominal conditions *1, *2 are subject to JIS B8615-1.			
* Due to continuing improvement, above specification may be subject to change without notice.			
			Unit converter BTU/h = kW x 3,412 cfm = m ³ /min x 35.31 lbs = kg / 0.4536
			*Above specification data is subject to rounding variation.

PLFY-MS20, 25, 32, 40, 50, 63, 80, 100, 125VEM-E

Unit: mm

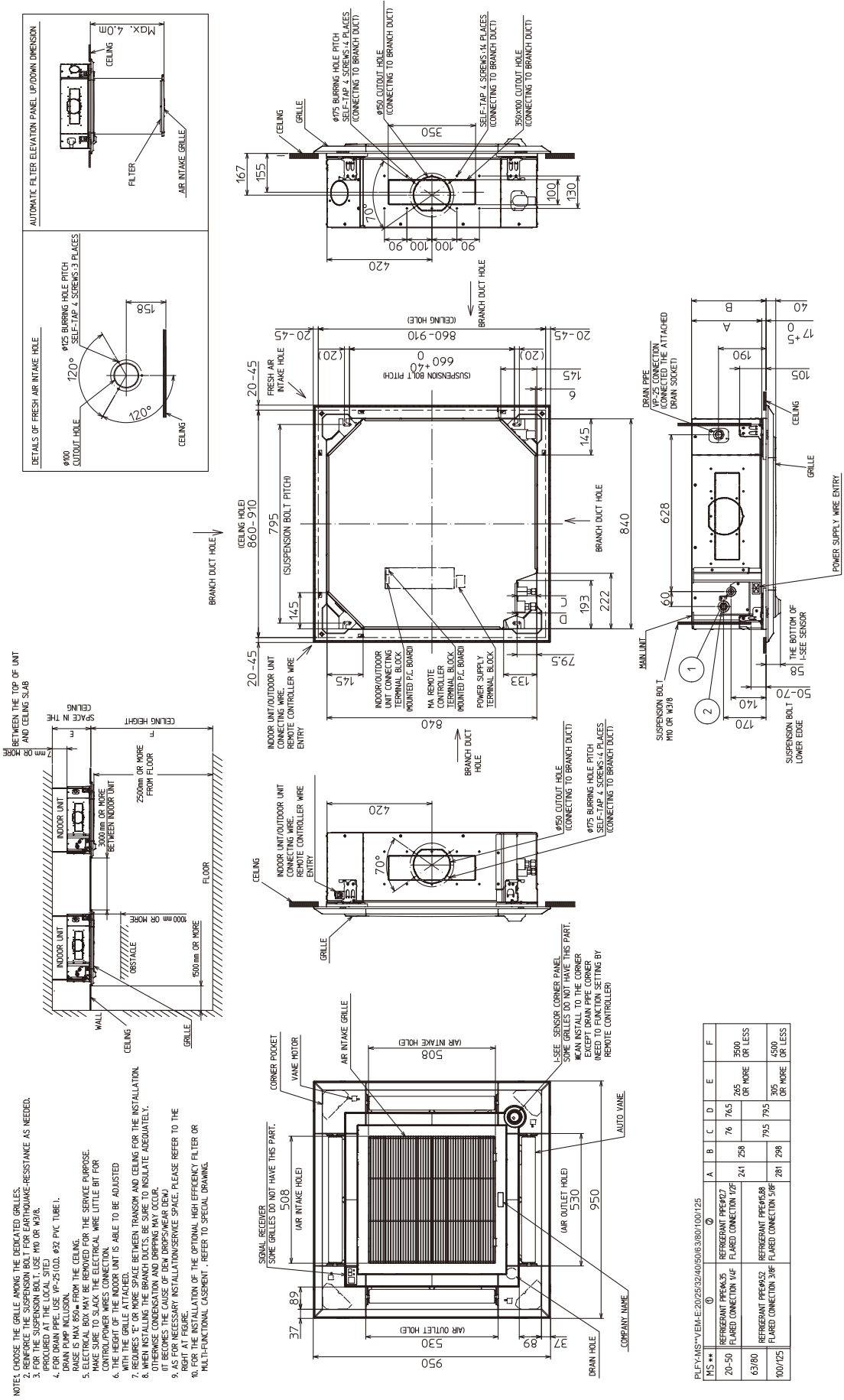

- NOTE: CHOOSE THE GRILLE AMONG THE DEDICATED GRILLES.
- 2. FOR THE SUSPENSION BOLT FOR EARTHQUAKE-RESISTANCE AS NEEDED.
- 3. FOR THE SUSPENSION BOLT FOR EARTHQUAKE-RESISTANCE AS NEEDED.
- 4. FOR DRAIN PIPE, USE VP-25 (OD. Ø32 PVC TUBE).
- 5. DRAIN PUMP INCLUSION.
- 6. RISE IS MAX. 650mm FROM THE CEILING.
- 7. MAKE SURE TO SLACK THE ELECTRICAL WIRE LITTLE BIT FOR CONTROL/POWER WIRES CONNECTION.
- 8. WITH THE GRILLE ATTACHED, BETWEEN TRANSOM AND CEILING FOR THE INSTALLATION OF THE BRANCH DUCTS, BRANCH DUCTS BE SURE TO INSULATE ADEQUATELY. OTHERWISE CONDENSATION AND DRIPPING MAY OCCUR.
- 9. AS FOR NECESSARY INSTALLATION/SERVICE SPACE, PLEASE REFER TO THE RIGHT AT FIGURE 1.
- 10. FOR THE INSTALLATION OF THE OPTIONAL HIGH-EFFICIENCY FILTER OR MULTI-FUNCTIONAL CASEMENT, REFER TO SPECIAL DRAWING.

PLFY-MS-VEM-E:20/25/32/40/50/63/80/100/125

MS**	REFRIGERANT	A	B	C	D	E	F
20-50	REFRIGERANT PPE#27 FLARED CONNECTION 1/2"	241	256	265	265	3000	OR MORE
63/80	REFRIGERANT PPE#52 FLARED CONNECTION 3/8"	281	296	305	305	4500	OR MORE
100/125	REFRIGERANT PPE#58 FLARED CONNECTION 1/2"	281	296	305	305	4500	OR MORE

PLFY-MS-VEM-E

PLFY-MS20, 25, 32, 40, 50, 63, 80, 100, 125VEM-E

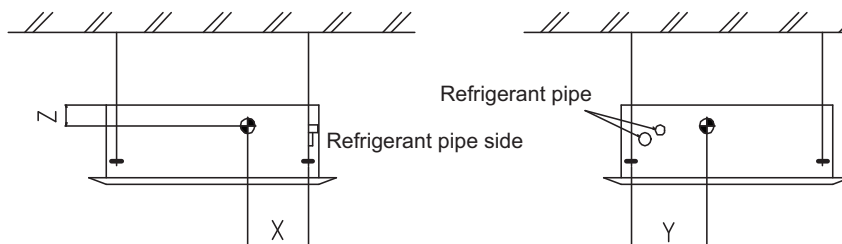

(mm)[in]

Model name	X	Y	Z
PLFY-MS20VEM-E	325 [12-13/16]	390 [15-3/8]	115 [4-17/32]
PLFY-MS25VEM-E	325 [12-13/16]	390 [15-3/8]	115 [4-17/32]
PLFY-MS32VEM-E	325 [12-13/16]	390 [15-3/8]	115 [4-17/32]
PLFY-MS40VEM-E	325 [12-13/16]	390 [15-3/8]	115 [4-17/32]
PLFY-MS50VEM-E	325 [12-13/16]	390 [15-3/8]	115 [4-17/32]
PLFY-MS63VEM-E	325 [12-13/16]	390 [15-3/8]	115 [4-17/32]
PLFY-MS80VEM-E	325 [12-13/16]	390 [15-3/8]	115 [4-17/32]
PLFY-MS100VEM-E	325 [12-13/16]	380 [14-31/32]	100 [3-15/16]
PLFY-MS125VEM-E	325 [12-13/16]	380 [14-31/32]	100 [3-15/16]

PLFY-MS20, 25, 32, 40, 50, 63, 80, 100, 125VEM-E

[LEGEND]

SYMBOL	NAME	SYMBOL	NAME
I.B	INDOOR CONTROLLER BOARD	MV	VANE MOTOR
CN32	CONNECTOR	TH21	THERMISTOR
CN51	CENTRALLY CONTROL	TH22	ROOM TEMP. DETECTION (0°C/15kΩ, 25°C/5.4kΩ)
CN52	REMOTE INDICATION	TH23	PIPE TEMP. DETECTION / LIQUID (0°C/15kΩ, 25°C/5.4kΩ)
CN105	IT TERMINAL		PIPE TEMP. DETECTION / GAS (0°C/15kΩ, 25°C/5.4kΩ)
F1	FUSE (T 6.3AL 250V)		
SW1	SWITCH	TB2	TERMINAL BLOCK
SW2	MODE SELECTION	TB5	POWER SUPPLY
SW3	CAPACITY CODE	TB15	TRANSMISSION
SW11	MODE SELECTION		MA-REMOTE CONTROLLER
SW12	ADDRESS SETTING 1s DIGIT		
SW14	ADDRESS SETTING 10s DIGIT		
SW21	BRANCH No.		
	CEILING HEIGHT		
	DISCHARGE OUTLET NUMBER		
	OPTION SELECTOR		
SW22	PAIR NO. SETTING		
SWE	DRAIN PUMP (TEST MODE)		
DP	DRAIN PUMP		
FS	DRAIN FLOAT SWITCH		
LEV	LINEAR EXPANSION VALVE		
MF	FAN MOTOR		
		W.B	PCB FOR WIRELESS REMOTE CONTROLLER
		BZ	BUZZER
		LED1	LED (OPERATION INDICATION : GREEN)
		LED2	LED (PREPARATION FOR HEATING : ORANGE)
		RU	RECEIVING UNIT
		SW1	EMERGENCY OPERATION (HEAT / DOWN)
		SW2	EMERGENCY OPERATION (COOL / UP)
		MT	i-see Sensor MOTOR

MA-Remote controller terminal block and transmission terminal block

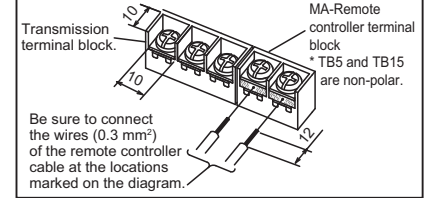

PLFY-MS-VEM-E

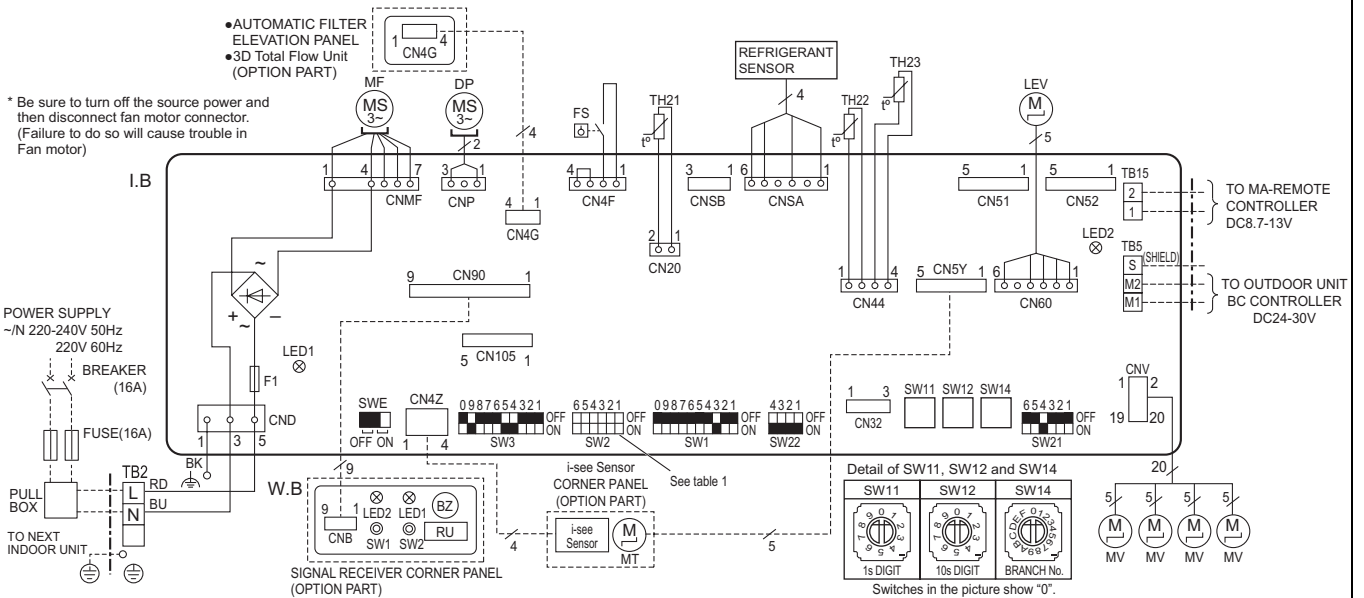

<Table 1>

MODELS	SW2	MODELS	SW2	MODELS	SW2
20	OFF ON	40	OFF ON	80	OFF ON
25	OFF ON	50	OFF ON	100	OFF ON
32	OFF ON	63	OFF ON	125	OFF ON

LED on indoor board for service

Mark	Meaning	Function
LED1	Main power supply	Main Power supply (Indoor unit:220-240V AC) power on → lamp is lit
LED2	Power supply for MA-Remote controller	Power supply for MA-Remote controller on → lamp is lit

NOTES:

- At servicing for outdoor unit, always follow the wiring diagram of outdoor unit.
- In case of using MA-Remote controller, please connect to TB15. (Remote controller wire is non-polar.)
- In case of using M-NET, please connect to TB5. (Transmission line is non-polar.)
- Symbol [S] of TB5 is the shield wire connection.
- Symbols used in wiring diagram are, : terminal block, : connector.
- The setting of SW2 differs in the capacity and model. For the detail, see table 1.
- Make sure to turn off the indoor and the outdoor units before replacing indoor controller board.
- The black square (■) in the wiring diagram indicates a switch position.
- When installing the automatic filter elevation panel and the 3D Total Flow Unit together, refer to the wiring diagram of the 3D Total Flow Unit.

5-1. Sound levels

PLFY-MS-VEM-E

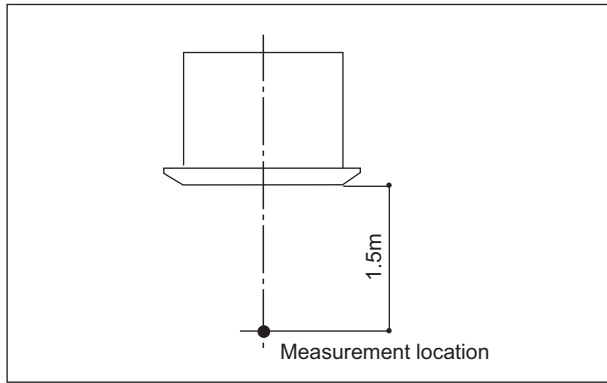

Sound level at anechoic room : Low-Mid2-Mid1-High

	Sound level dB (A)
PLFY-MS20VEM-E	24-26-27-29
PLFY-MS25VEM-E	
PLFY-MS32VEM-E	26-27-29-31
PLFY-MS40VEM-E	
PLFY-MS50VEM-E	28-29-30-32
PLFY-MS63VEM-E	
PLFY-MS80VEM-E	28-31-34-37
PLFY-MS100VEM-E	
PLFY-MS125VEM-E	35-39-42-45

* Measured in anechoic room.

PLFY-MS-VEM-E

5-2. NC curves

PLFY-MS20, 25VEM-E

External Static Pressure: 0Pa [0.00in.WG]
Power Source: 220,230,240V, 50Hz/220V, 60Hz

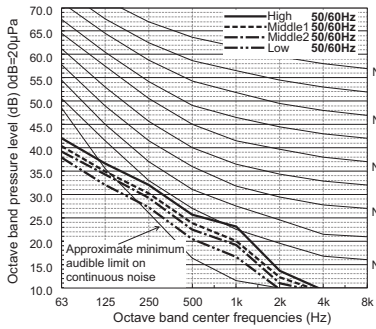

PLFY-MS32, 40, 50VEM-E

External Static Pressure: 0Pa [0.00in.WG]
Power Source: 220,230,240V, 50Hz/220V, 60Hz

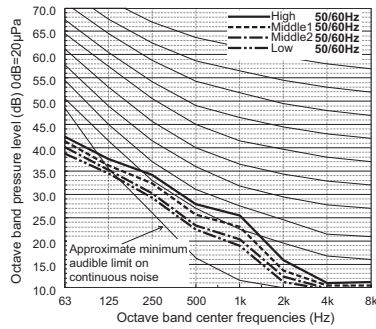

PLFY-MS63VEM-E

External Static Pressure: 0Pa [0.00in.WG]
Power Source: 220,230,240V, 50Hz/220V, 60Hz

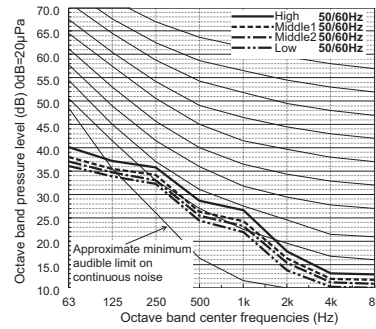

PLFY-MS80VEM-E

External Static Pressure: 0Pa [0.00in.WG]
Power Source: 220,230,240V, 50Hz/220V, 60Hz

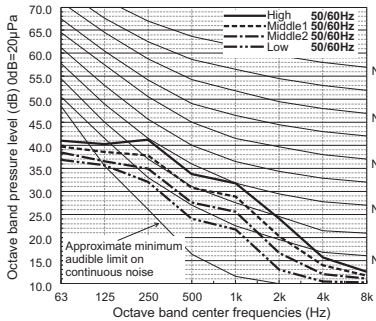

PLFY-MS100VEM-E

External Static Pressure: 0Pa [0.00in.WG]
Power Source: 220,230,240V, 50Hz/220V, 60Hz

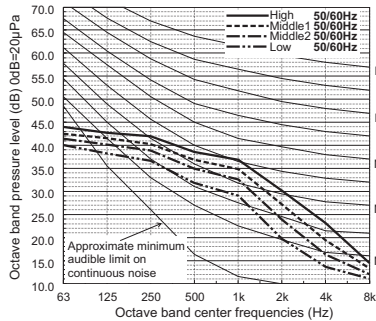

PLFY-MS125VEM-E

External Static Pressure: 0Pa [0.00in.WG]
Power Source: 220,230,240V, 50Hz/220V, 60Hz

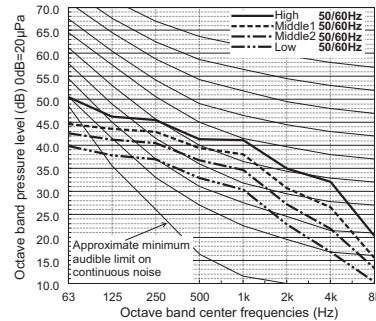

6-1. Temperature distributions

PLFY-MS80VEM-E

<Cooling mode> Standard
 Flow angle : 10° 4-way flow
 Ceiling height : 2.7m

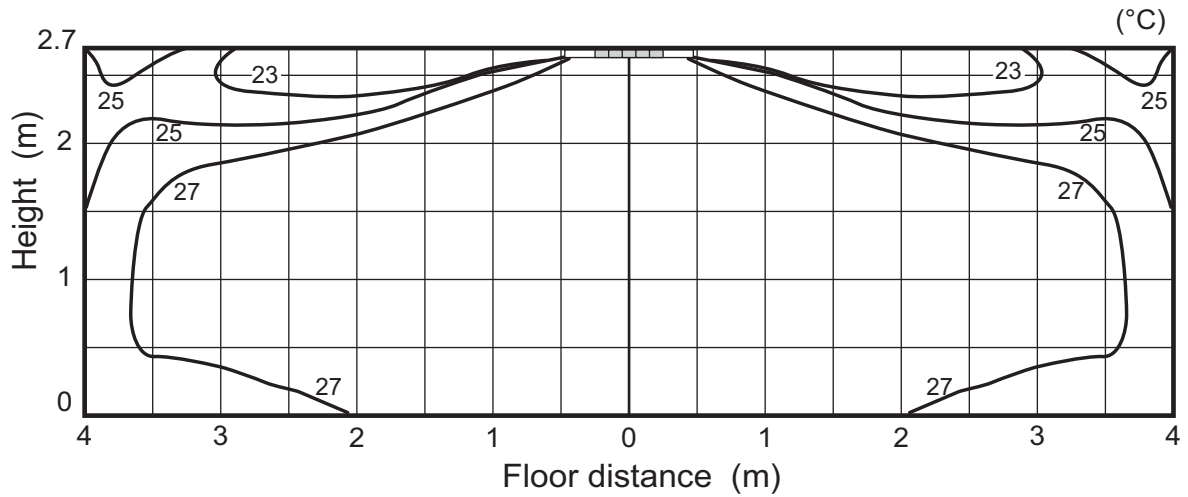

<Heating mode> Standard
 Flow angle : 60° 4-way flow
 Ceiling height : 2.7m

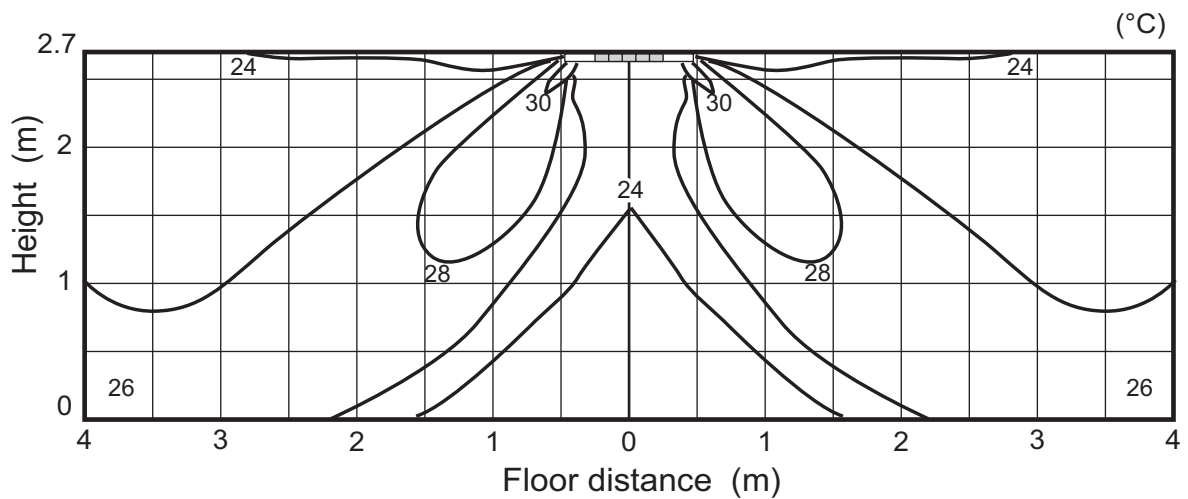

Note : These figures show typical temperature distributions in the conditions above. In the actual installation, they may differ from these figures under the influence of air temperature conditions, ceiling height, cooling/heating load, obstacles, etc.

PLFY-MS100VEM-E

<Cooling mode> Standard
 Flow angle : 10° 4-way flow
 Ceiling height : 3.2m

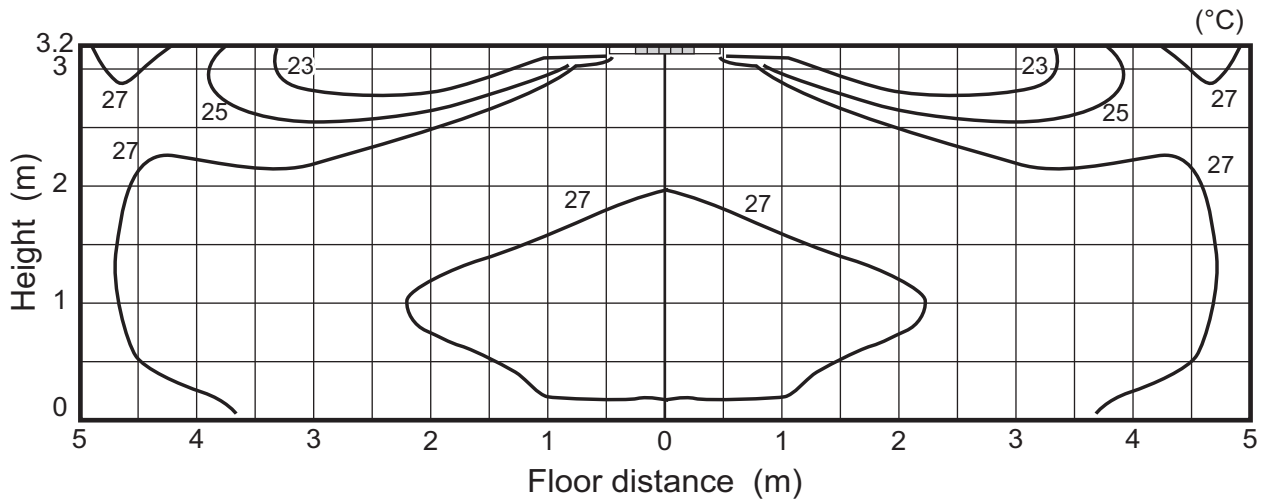

<Heating mode> Standard
 Flow angle : 60° 4-way flow
 Ceiling height : 3.2m

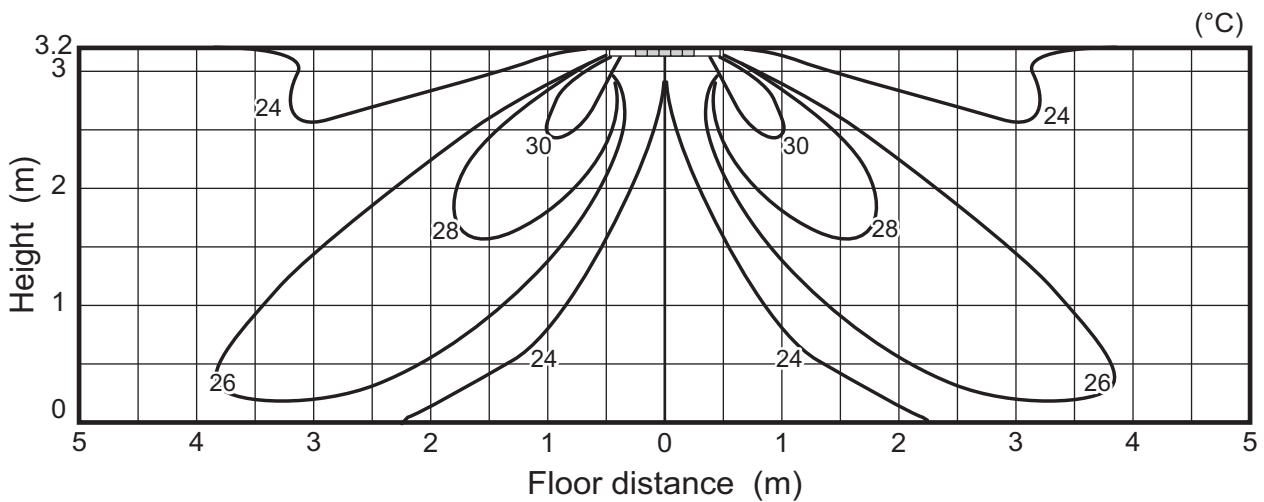

Note : These figures show typical temperature distributions in the conditions above. In the actual installation, they may differ from these figures under the influence of air temperature conditions, ceiling height, cooling/heating load, obstacles, etc.

PLFY-MS-VEM-E

6-2. Airflow distributions

PLFY-MS80VEM-E

<Cooling mode> Standard
 Flow angle : 10° 4-way flow
 Ceiling height : 2.7m

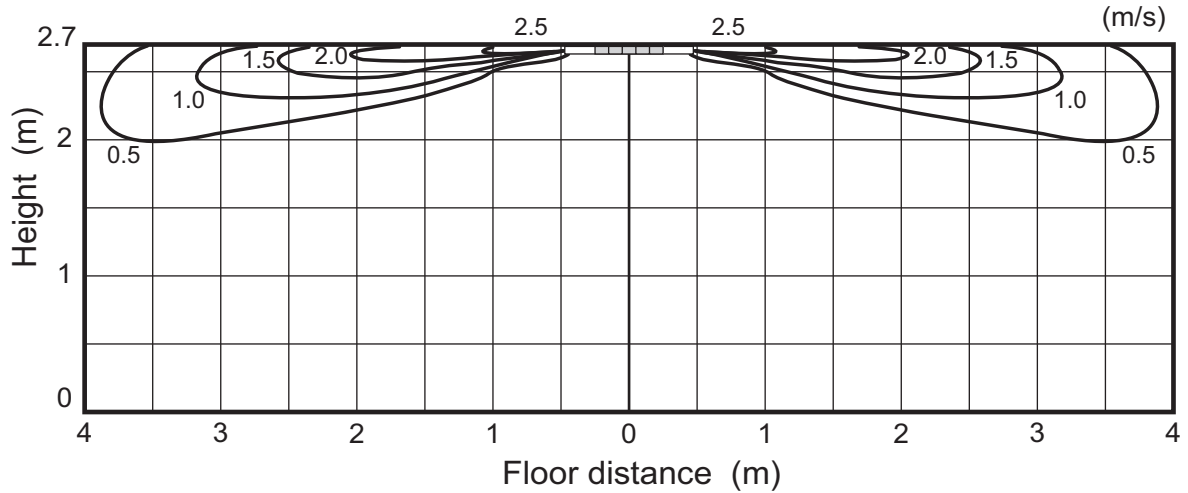

<Heating mode> Standard
 Flow angle : 60° 4-way flow
 Ceiling height : 2.7m

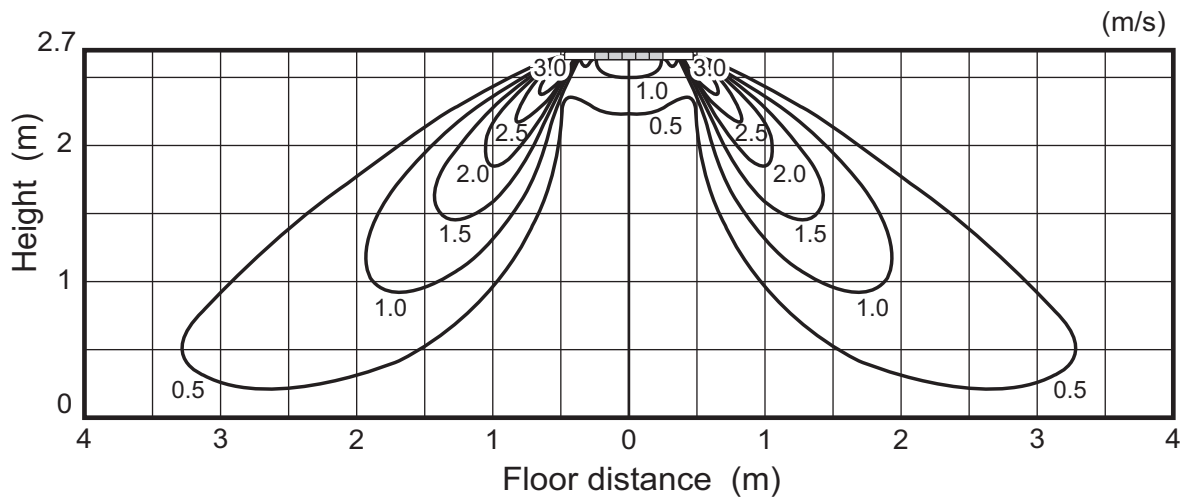

Note : These figures show typical temperature distributions in the conditions above. In the actual installation, they may differ from these figures under the influence of air temperature conditions, ceiling height, cooling/heating load, obstacles, etc.

PLFY-MS100VEM-E

<Cooling mode> Standard
 Flow angle : 10° 4-way flow
 Ceiling height : 3.2m

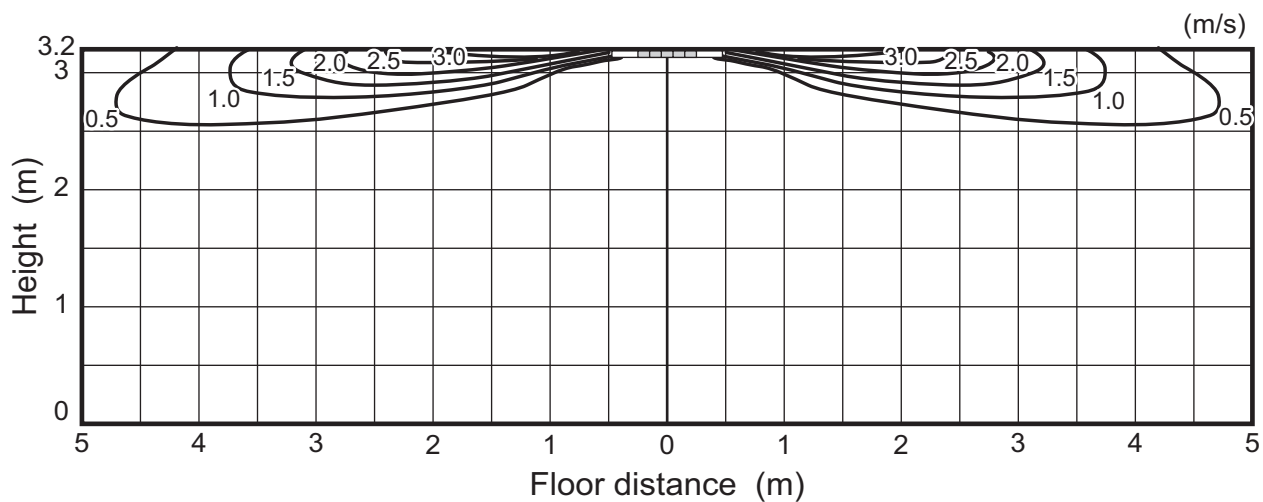

<Heating mode> Standard
 Flow angle : 60° 4-way flow
 Ceiling height : 3.2m

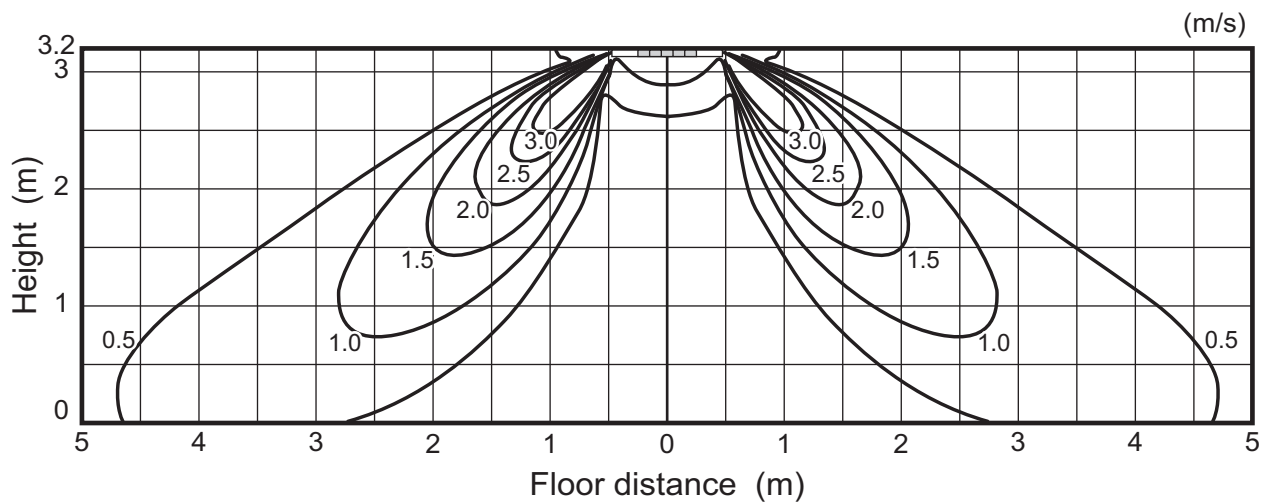

Note : These figures show typical temperature distributions in the conditions above. In the actual installation, they may differ from these figures under the influence of air temperature conditions, ceiling height, cooling/heating load, obstacles, etc.

7. ELECTRICAL CHARACTERISTICS

Ceiling cassette (4-way flow type)

Symbols: MCA (Max.Circuit Amps =1.25xFLA), FLA (Full Load Amps)
IFM (Indoor Fan Motor), Output (Fan motor rated output)

Model name	Power supply			IFM	
	Volts/Hz	Range +-10%	MCA(A)	Output (kW)	FLA(A)
PLFY-MS20VEM-E	220-240V/50Hz 220V/60Hz	Max.: 264V Min.: 198V	0.39	0.05	0.31
PLFY-MS25VEM-E			0.39	0.05	0.31
PLFY-MS32VEM-E			0.40	0.05	0.32
PLFY-MS40VEM-E			0.40	0.05	0.32
PLFY-MS50VEM-E			0.40	0.05	0.32
PLFY-MS63VEM-E			0.45	0.05	0.36
PLFY-MS80VEM-E			0.63	0.05	0.50
PLFY-MS100VEM-E			0.84	0.12	0.67
PLFY-MS125VEM-E			1.33	0.12	1.06

PLFY-MS-VEM-E

8-1. Optional parts line up for the Indoor unit

	Description	Model
PLFY-MS-VEM-E	Air outlet shutter plate	PAC-SJ37SP-E
	Multi-function casement	PAC-SJ41TM-E
	High efficiency filter element	PAC-SH59KF-E
	3D i-see Sensor corner panel	PAC-SE1ME-E
	Auto elevation and signal receiver panel	PLP-6EAJ
	Auto elevation, 3D i-see Sensor and signal receiver panel	PLP-6EAJE
	Wireless signal receiver	PAR-SE9FA-E
	Space panel	PAC-SJ65AS-E
	Duct flange for fresh air intake	PAC-SH65OF-E
	3D total flow unit	PLP-U160ELR-E
	Plasma Quad Connect	PAC-SK51FT-E

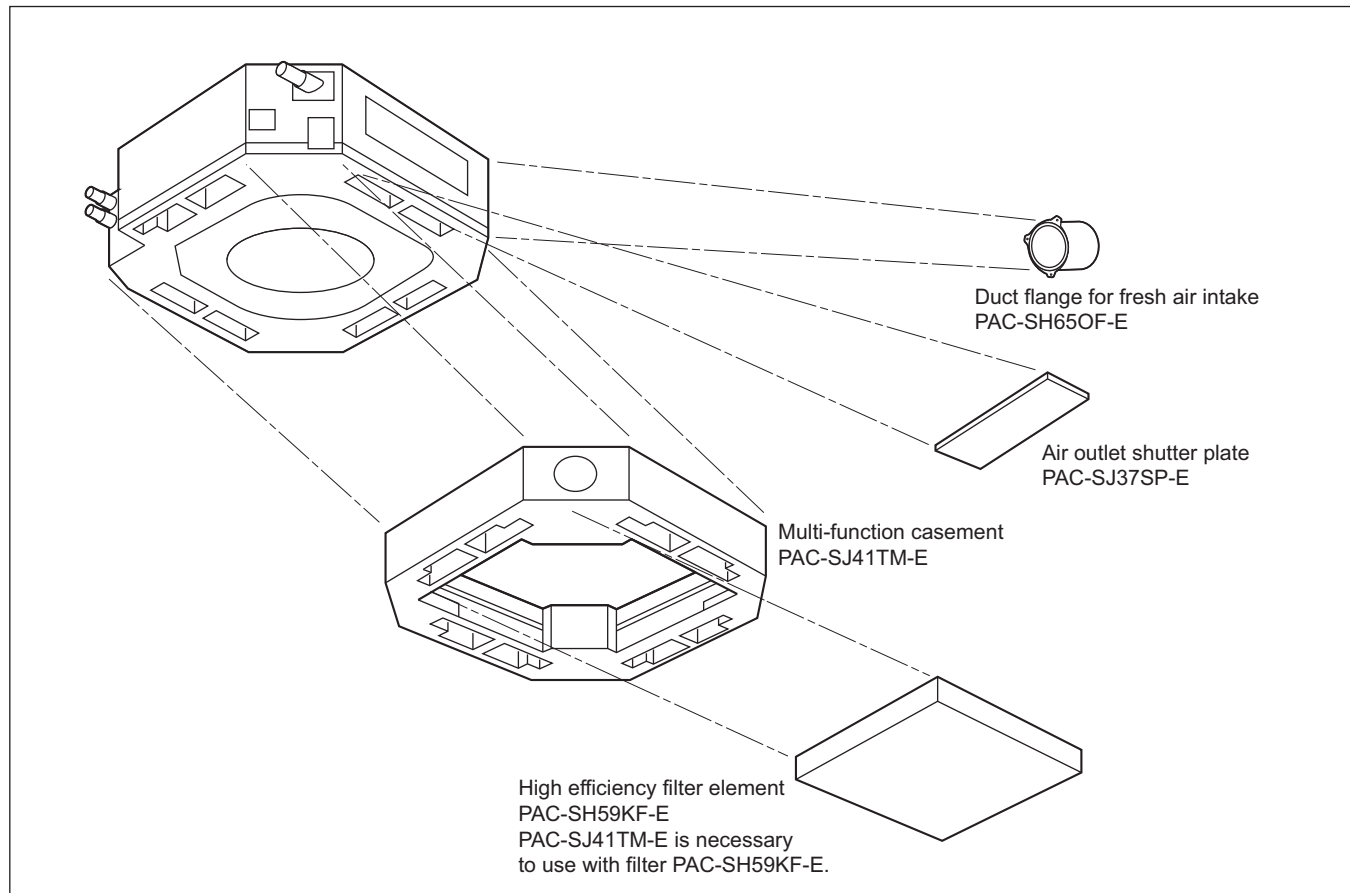

8-2. Air outlet shutter plate

Using the air outlet shutter plate to block the air outlet to modify the air-way from 4 to 3 or 2.
 With one shutter plate, 4 air-ways can be changed to 3;
 With two shutter plates, 4 air-ways can be changed to 2;
 Changing to 1 way is not allowed.
 Material: Foamed polyethylene + foamed urethane, color: Black

Item	Shutter plate	Shutter plate	
Quantity	2	1	
Shape			

Detailed installation information should be referred to its Installation Manual.

8-3. High efficiency filter element

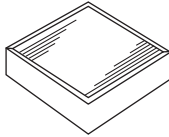

Life span: 2,500 hr (Dust concentration 0.15mg/m³); Colorimetric method 65% (JIS 11 class); No re-production.
 * The actual dust situation affects the filter life span, which should be considered at the applying site.
 Material: Electrostatic polyolefin fiber
 High efficiency filter element PAC-SH59KF-E should be used together with the Multi-function casement PAC-SJ41TM-E. When using PAC-SH59KF-E, switching on SW21-5 of the Indoor unit address board is needed. Details should be referred to its Installation Manual.

Quantity	1	
Shape		

Detailed installation information is referred in its Installation Manual.

8-4. Multi-function casement

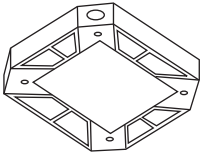
Multi-function casement is used for High efficiency filter element and/or fresh air intake from outdoor.
 It should be used with High efficiency filter element PAC-SH59KF-E (Colorimetric method 65%).
 Fresh air intake on the Multi-function casement is possible from any 2 or less corners among the 4 ones.
 But duct and flange on the casement should be prepare locally.

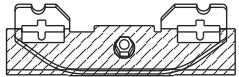
Item	Multi-functional casement	Screw with washer (black)	Screw	Grille securing bracket
Quantity	1	4	8	4
Shape		M5 × 0.8 × 25 	M5 × 0.8 × 12 	With insulator 

Detailed installation information should be referred to its Installation Manual.

8-5. 3D i-see Sensor corner panel

3D i-see Sensor provides comfortable space as it detects the floor temperature to prevent spotty temperature.
 And that enables the unit to save energy.
 Attention
 Make sure that there are no gaps between the unit and the grille, and the grille and ceiling.
 * It may cause dew dripping.

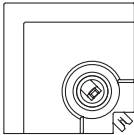

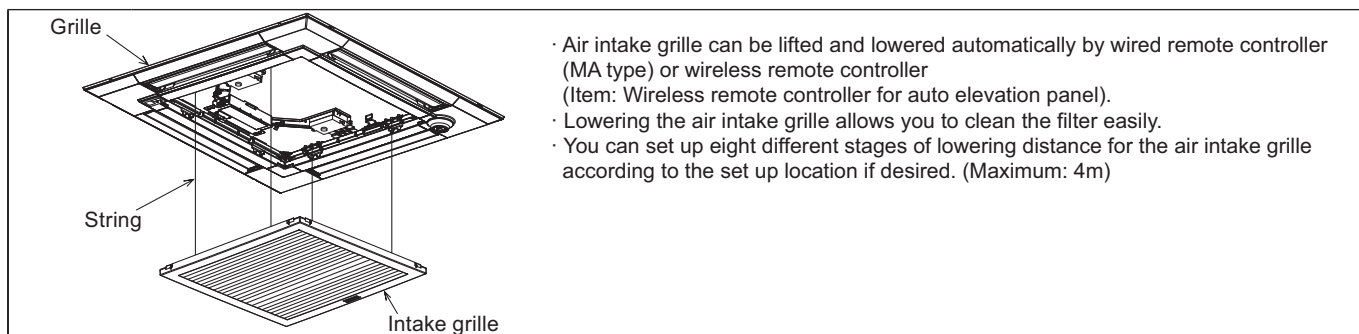

Item	3D i-see Sensor corner panel	
Quantity	1	
Shape		

Detailed installation information should be referred to its Installation Manual.

8-6. Auto elevation panel

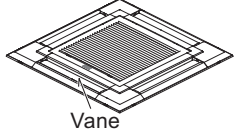
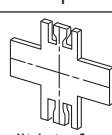
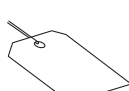

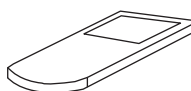
- Air intake grille can be lifted and lowered automatically by wired remote controller (MA type) or wireless remote controller (Item: Wireless remote controller for auto elevation panel).
- Lowering the air intake grille allows you to clean the filter easily.
- You can set up eight different stages of lowering distance for the air intake grille according to the set up location if desired. (Maximum: 4m)

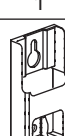
Item	Grille	Installation gauge	Tag	Screw
Quantity	1	1	1	2
Shape		 (Used split into four pieces)		 4 × 16
Item	Wireless remote controller for auto elevation panel	Battery	Remote controller holder	
Quantity	1	1	1	
Shape		 Lithium battery CR2025 3V		

Grille with 3D i-see Sensor

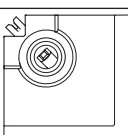
Item	Screw	3D i-see Sensor corner panel
Quantity	1	1
Shape	 4 × 16	

Detailed installation information should be referred to its Installation Manual.

8-7. Wireless signal receiver

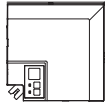

Wireless signal receiver PAR-SE9FA-E is necessary for using wireless remote controller		
Item	Wireless signal receiver	
Quantity	1	
Shape		

Detailed installation information should be referred to its Installation Manual.

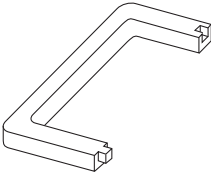
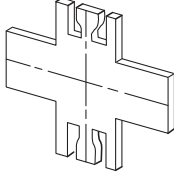
8-8. Space panel

Decorative cover for the installation when the ceiling height is low.		
Item	Space panel	Gauge for installation
Quantity	2	1
Shape		<p>(Split this into four pieces)</p> 

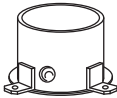
8-9. Duct flange for fresh air intake

Part to attach a duct to take in fresh air from outdoors.			
Item	Duct flange	Insulator	Screws (M4 x 10)
Quantity	1	1	3
Shape			

8-10. 3D Total flow unit

PLFY-MS-VEM-E

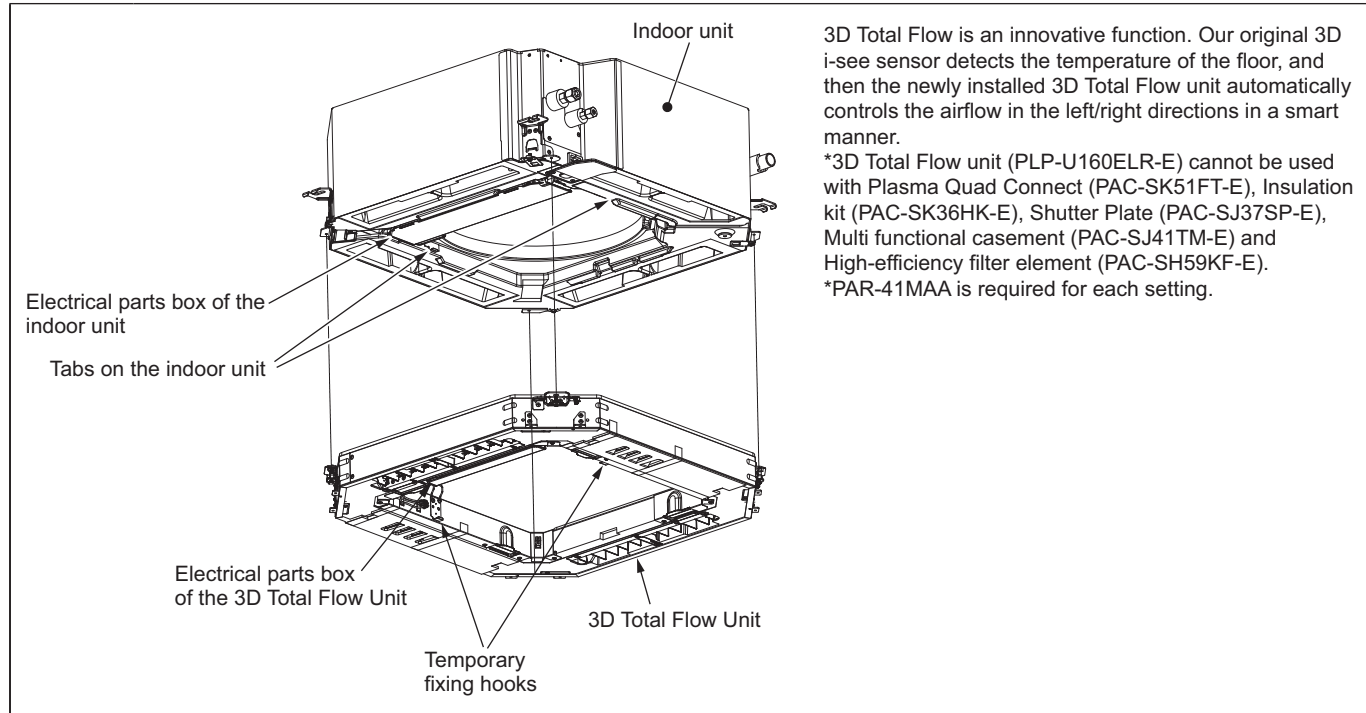

3D Total Flow is an innovative function. Our original 3D i-see sensor detects the temperature of the floor, and then the newly installed 3D Total Flow unit automatically controls the airflow in the left/right directions in a smart manner.
 *3D Total Flow unit (PLP-U160ELR-E) cannot be used with Plasma Quad Connect (PAC-SK51FT-E), Insulation kit (PAC-SK36HK-E), Shutter Plate (PAC-SJ37SP-E), Multi functional casement (PAC-SJ41TM-E) and High-efficiency filter element (PAC-SH59KF-E).
 *PAR-41MAA is required for each setting.

Item	3D Total Flow Unit	Screw	Mounting bracket for the grille	Rectifier piece
Quantity	1	8	4	1
Shape		M5×12 		
Item	Screw	Corner panel insulator		
Quantity	1	1		
Shape	ST4×10 	 Note: One sheet consists of 8 insulators.		

8-11. Plasma Quad Connect

PAC-SK51FT-E connects to CN105 on the indoor unit. When using an additional optional part, connect it to CN105 of PAC-SK51FT-E.

Item	Plasma Quad Connect	Screw with washer (black)	Screw	Grille securing bracket
Quantity	1	4	8	4
Shape		M5 × 0.8 × 25 	M5 × 0.8 × 12 	With insulator

Detailed installation information should be referred to its Installation Manual.

⚠ Warning

- Do not use refrigerant other than the type indicated in the manuals provided with the unit and on the nameplate.
 - Doing so may cause the unit or pipes to burst, or result in explosion or fire during use, repair, or at the time of disposal of the unit.
 - It may also be in violation of applicable laws.
 - MITSUBISHI ELECTRIC CORPORATION cannot be held responsible for malfunctions or accidents resulting from the use of the wrong type of refrigerant.
- Our air conditioning equipment and heat pumps contain a fluorinated greenhouse gas, R32.

MITSUBISHI ELECTRIC CORPORATION

www.MitsubishiElectric.com