

PARTS CATALOG

Series PKFY Wall Mounted R410A

Indoor unit

[Model Name]

 PKFY-P10VLM-E
 PKFY-P10VLM-ET

 PKFY-P15VLM-E
 PKFY-P15VLM-ET

 PKFY-P20VLM-E
 PKFY-P20VLM-ET

 PKFY-P25VLM-E
 PKFY-P25VLM-ET

 PKFY-P32VLM-E
 PKFY-P32VLM-ET

 PKFY-P40VLM-E
 PKFY-P40VLM-ET

 PKFY-P50VLM-E
 PKFY-P50VLM-ET

[Service Ref.]

 PKFY-P10VLM-ER1.TH
 PKFY-P10VLM-ETR1.TH

 PKFY-P15VLM-ER1.TH
 PKFY-P15VLM-ETR1.TH

 PKFY-P20VLM-ER1.TH
 PKFY-P20VLM-ETR1.TH

 PKFY-P25VLM-ER1.TH
 PKFY-P25VLM-ETR1.TH

 PKFY-P32VLM-ER1.TH
 PKFY-P32VLM-ETR1.TH

 PKFY-P40VLM-ER1.TH
 PKFY-P40VLM-ETR1.TH

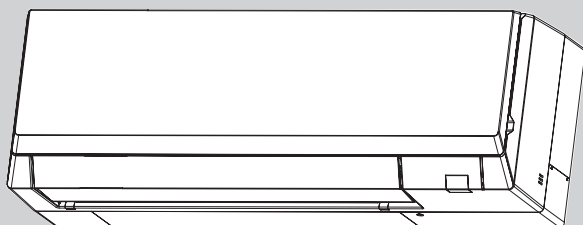
 PKFY-P50VLM-ER1.TH
 PKFY-P50VLM-ETR1.TH

INDOOR UNIT

 Model name
 indication

CONTENTS

- 1. SERVICE PARTS LIST 2
- 2. OPTIONAL PARTS 6

SERVICE MANUAL (TCH071)

CITY MULTI

1-1. PANEL AND HEAT EXCHANGER PARTS

PKFY-P10VLM-(ER1/ETR1).TH

PKFY-P20VLM-(ER1/ETR1).TH

PKFY-P32VLM-(ER1/ETR1).TH

PKFY-P50VLM-(ER1/ETR1).TH

PKFY-P15VLM-(ER1/ETR1).TH

PKFY-P25VLM-(ER1/ETR1).TH

PKFY-P40VLM-(ER1/ETR1).TH

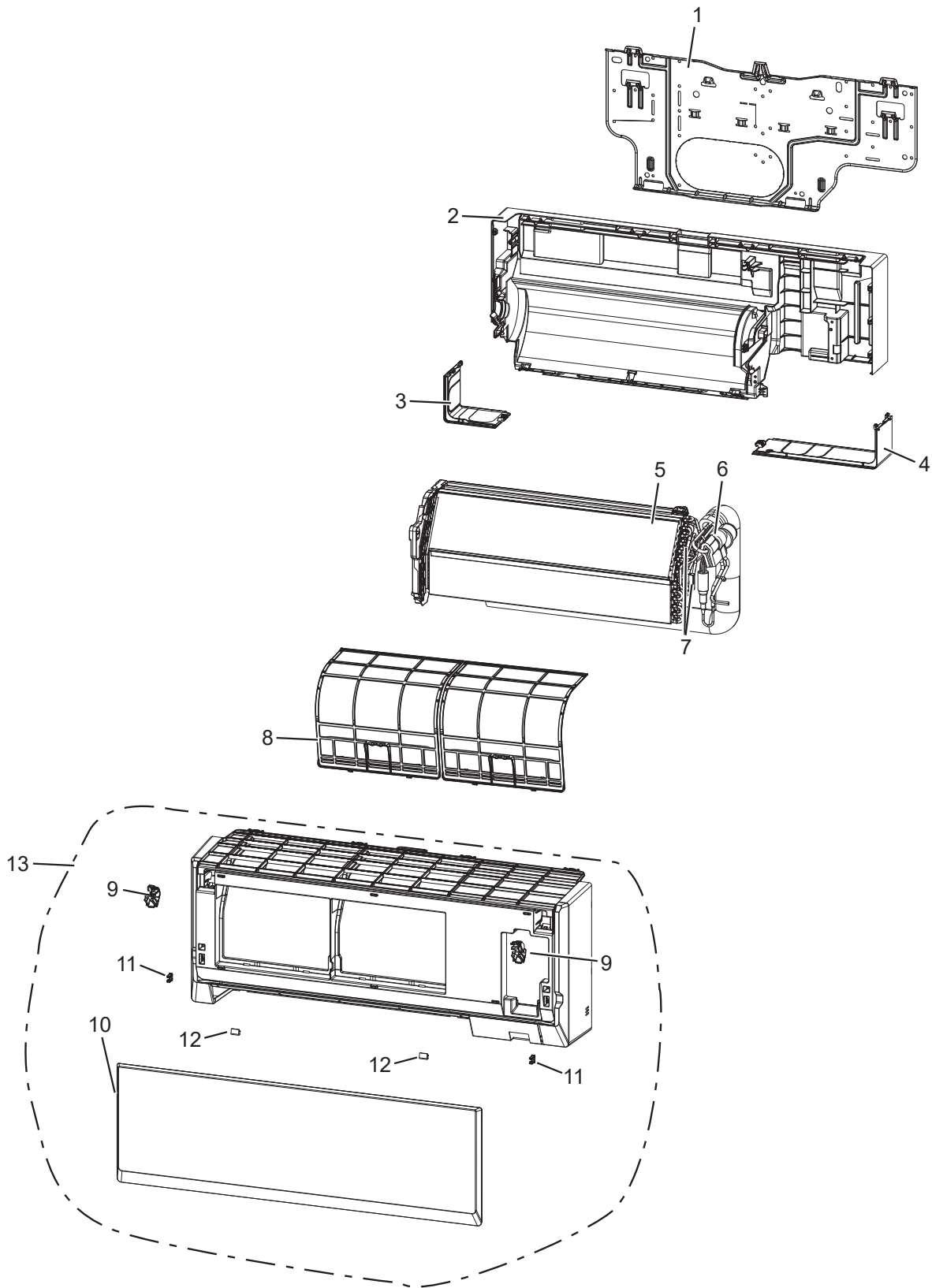

PANEL AND HEAT EXCHANGER PARTS

No.	Part No.	Part Name	Q'ty/unit											Remarks (Drawing No.)	Wiring Diagram Symbol	
			PKFY-P10VLM-ER1.TH	PKFY-P15VLM-ER1.TH	PKFY-P20VLM-ER1.TH	PKFY-P25VLM-ER1.TH	PKFY-P32VLM-ER1.TH	PKFY-P40VLM-(ER1/ETR1).TH	PKFY-P50VLM-(ER1/ETR1).TH	PKFY-P10VLM-ETR1.TH	PKFY-P15VLM-ETR1.TH	PKFY-P20VLM-ETR1.TH	PKFY-P25VLM-ETR1.TH			PKFY-P32VLM-ETR1.TH
1	E27 P63 970	INSTALLATION PLATE	1	1	1	1	1			1	1	1	1	1		
	E27 P68 970	INSTALLATION PLATE						1	1							
2	E27 P63 234	BOX ASSEMBLY	1	1	1	1	1									
	E27 P68 234	BOX ASSEMBLY						1	1							
	E27 P70 234	BOX ASSEMBLY								1	1	1	1	1		
3	E27 P63 976	CORNER BOX L	1	1	1	1	1	1	1	1	1	1	1	1		
4	E27 P63 975	CORNER BOX R	1	1	1	1	1	1	1	1	1	1	1	1		
5	E27 P63 620	INDOOR HEAT EXCHANGER	1							1					Includes connect pipes	
	E27 P64 620	INDOOR HEAT EXCHANGER		1	1	1	1				1	1	1	1		
	E27 P68 620	INDOOR HEAT EXCHANGER						1	1							
6	E27 P63 640	LINER EXPANSION VALVE	1							1						LEV
	E27 P64 640	LINER EXPANSION VALVE		1	1	1	1	1	1		1	1	1	1		LEV
7	E27 P63 307	INDOOR COIL THERMISTOR	1	1	1	1	1	1	1	1	1	1	1	1		TH22, TH23
8	E27 65K 100	AIR FILTER	2	2	2	2	2			2	2	2	2	2	VK25A182G01	
	E27 58G 100	AIR FILTER						2	2						VK25A181G01	
9	E27 P63 021	ARM HOLDER SET	1	1	1	1	1	1	1	1	1	1	1	1	Set (left, right)	
10	E27 P63 010	FRONT PANEL	1	1	1	1	1			1	1	1	1	1		
	E27 P68 010	FRONT PANEL						1	1							
11	E22 F95 142	CATCH	2	2	2	2	2	2	2	2	2	2	2	2	2 pcs/set	
12	E22 98B 067	SCREW CAP	2	2	2	2	2	2	2	2	2	2	2	2	2 pcs/set	
13	E27 P63 000	PANEL ASSEMBLY	1	1	1	1	1			1	1	1	1	1	Includes 9,10,11,12	
	E27 P68 000	PANEL ASSEMBLY						1	1							

1-2. ELECTRICAL PARTS

PKFY-P10VLM-(ER1/ETR1).TH

PKFY-P20VLM-(ER1/ETR1).TH

PKFY-P32VLM-(ER1/ETR1).TH

PKFY-P50VLM-(ER1/ETR1).TH

PKFY-P15VLM-(ER1/ETR1).TH

PKFY-P25VLM-(ER1/ETR1).TH

PKFY-P40VLM-(ER1/ETR1).TH

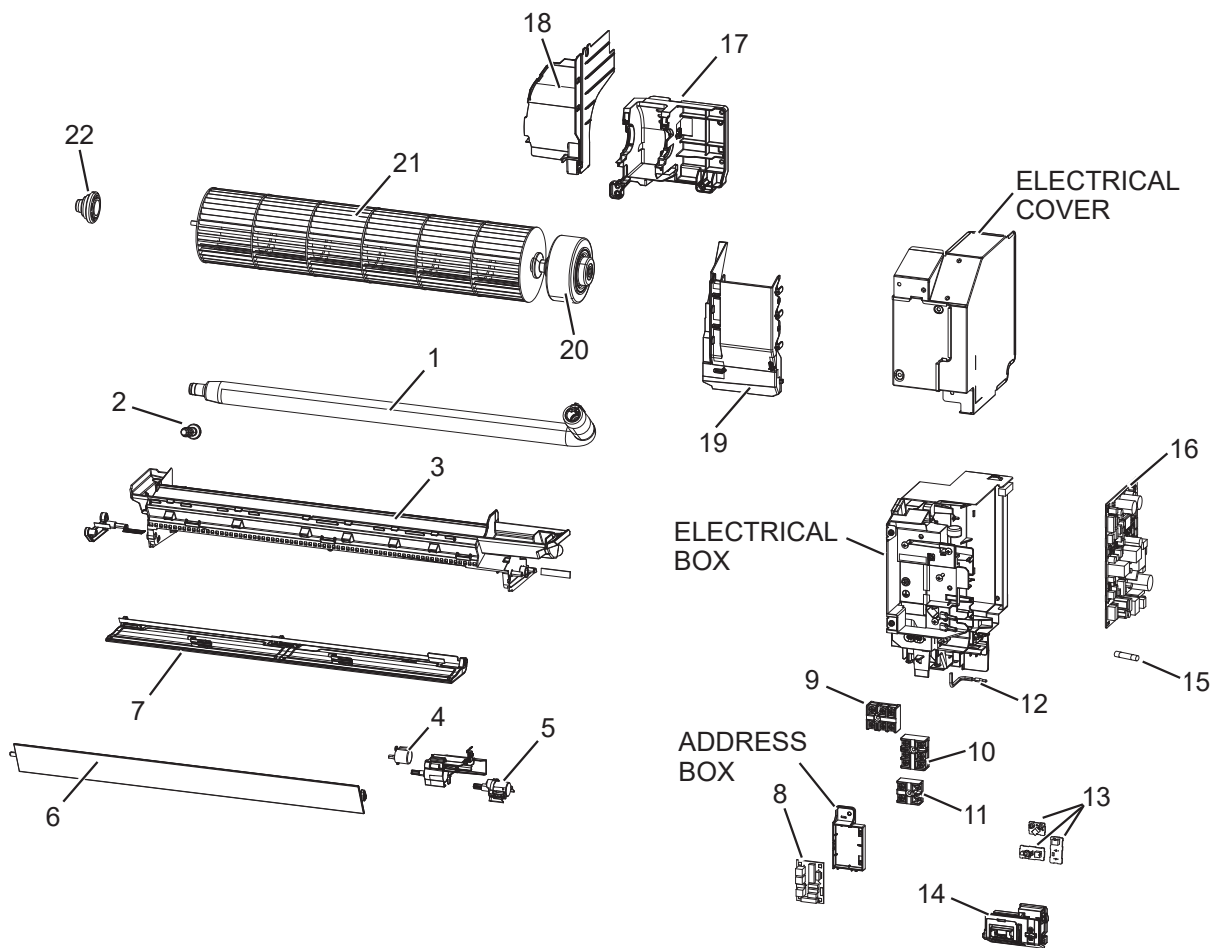

ELECTRICAL PARTS

No.	Part No.	Part Name	Q'ty/unit							Remarks (Drawing No.)	Wiring Diagram Symbol
			PKFY-P10VLM-(ER1/ETR1).TH	PKFY-P15VLM-(ER1/ETR1).TH	PKFY-P20VLM-(ER1/ETR1).TH	PKFY-P25VLM-(ER1/ETR1).TH	PKFY-P32VLM-(ER1/ETR1).TH	PKFY-P40VLM-(ER1/ETR1).TH	PKFY-P50VLM-(ER1/ETR1).TH		
1	E22 T20 702	DRAIN HOSE	1	1	1	1	1	1	1		
2	-	DRAIN CAP	1	1	1	1	1	1	1	SU26R611H01	
3	E27 76G 235	NOZZLE ASSEMBLY	1	1	1	1	1			Full assembly except drain hose	
	E27 77G 235	NOZZLE ASSEMBLY						1	1		
4	E27 103 303	VANE MOTOR (UPPER)	1	1	1	1	1	1	1		MV1
5	E22 Y54 303	VANE MOTOR (LOWER)	1	1	1	1	1	1	1		MV2
6	E27 76G 040	VANE UPPER	1	1	1	1	1			RK00R052G09	
	E27 77G 040	VANE UPPER						1	1	RK00R052G08	
7	E27 76G 041	VANE LOWER	1	1	1	1	1			RK00R053G11	
	E27 77G 041	VANE LOWER						1	1	RK00R053G10	
8	E27 696 456	ADDRESS BOARD	1	1	1	1	1	1	1		A.B.
9	E27 518 375	TERMINAL BLOCK	1	1	1	1	1	1	1	Power supply	TB2
10	E27 519 375	TERMINAL BLOCK	1	1	1	1	1	1	1	Transmission	TB5
11	E27 249 375	TERMINAL BLOCK	1	1	1	1	1	1	1	MA-Remote controller	TB15
12	E27 P63 308	ROOM TEMP. THERMISTOR	1	1	1	1	1	1	1		TH21
13	E27 P63 468	PCB FOR WIRELESS REMOTE CONTROLLER (W.B),SWITCH BOARD (S.B) and LED BOARD (L.B)	1	1	1	1	1	1	1	Combined PCB	L.B., W.B., S.B.
14	E27 P63 095	DISPLAY RECEIVER HOLDER	1	1	1	1	1	1	1		
15	E22 A49 382	FUSE	1	1	1	1	1	1	1	T3.15AL250V	F1
16	E27 P63 447	INDOOR CONTROLLER BOARD	1	1	1	1	1	1	1		I.B.
17	E27 P64 333	MOTOR BED	1	1	1	1	1	1	1		
18	E27 P63 333	MOTOR BAND	1	1	1	1	1	1	1		
19	E27 P63 541	WATER COVER	1	1	1	1	1	1	1		
20	E27 P63 300	INDOOR FAN MOTOR	1	1	1	1	1	1	1	Includes rubber mounts	MF
21	E27 P63 302	LINE FLOW FAN	1	1	1	1	1				
	E27 P68 302	LINE FLOW FAN						1	1		
22	E22 A89 509	BEARING MOUNT ASSEMBLY	1	1	1	1	1	1	1		
23	E22 C32 667	UNION (LIQ)	1	1	1	1	1	1	1	for liquid	
24	E22 179 667	UNION (GAS)	1	1	1	1	1	1	1	for gas	

Parts number that is circled is not shown in the figure.

2**OPTIONAL PARTS****2-1. EXTERNAL LEV BOX**

Part No.	PAC-SG95LE-E for P15-50 PAC-SK17LE-E for P10
----------	-------------------------------------------------

2-2. WIRELESS REMOTE CONTROLLER

Part No.	PAR-SL101A-E
----------	--------------

2-3. WIRED REMOTE CONTROLLER (MA REMOTE CONTROLLER)

Part No.	PAR-21MAA PAR-41MAA
----------	------------------------

2-4. WIRED REMOTE CONTROLLER (SIMPLE MA REMOTE CONTROLLER)

Part No.	PAC-YT52CRA
----------	-------------

2-5. WIRED REMOTE CONTROLLER (SMART ME CONTROLLER)

Part No.	PAR-U02MEDA
----------	-------------

2-6. Wi-Fi INTERFACE

Part No.	MAC-587IF-E
----------	-------------

2-7. REMOTE ON/OFF ADAPTOR

Part No.	PAC-SE55RA-E
----------	--------------

2-8. REMOTE DISPLAY ADAPTOR

Part No.	PAC-SA88HA-E
----------	--------------

2-9. REMOTE SENSOR

Part No.	PAC-SE41TS-E
----------	--------------

2-10. DRAIN PUMP KIT

Part No.	PAC-SK01DM-E
----------	--------------

2-11. V BLOCKING FILTER

Part No.	MAC-2470FT-E FOR PKFY-P45-P50 MAC-2471FT-E FOR PKFY-P10-P32
----------	----------------------------------------------------------------

MITSUBISHI ELECTRIC CORPORATION

HEAD OFFICE : TOKYO BUILDING, 2-7-3, MARUNOUCHI, CHIYODA-KU, TOKYO 100-8310, JAPAN

MITSUBISHI ELECTRIC CONSUMER PRODUCTS (THAILAND) CO., LTD.

700/406 MOO 7, TAMBON DON HUA ROH,
AMPHUR MUANG, CHONBURI 20000 THAILAND

Published: Oct. 2021. No. TCB071

Made in Thailand

Specifications are subject to change without notice.