

TECHNICAL & SERVICE MANUAL

Series PKFY Wall Mounted

R32
Indoor unit
[Model names]
[Service Ref.]
PKFY-MS63VKM-E
PKFY-MS63VKM-E.TH
PKFY-MS63VKM-ER1.TH
PKFY-MS63VKM-ET
PKFY-MS63VKM-ET.TH
PKFY-MS63VKM-ETR1.TH
PKFY-MS100VKM-E
PKFY-MS100VKM-E.TH
PKFY-MS100VKM-ER1.TH
PKFY-MS100VKM-ET
PKFY-MS100VKM-ET.TH
PKFY-MS100VKM-ETR1.TH
Note:

- This manual describes only service data of the indoor units.

Revision:

- PKFY-MS63VKM-ER1.TH, PKFY-MS63VKM-ETR1.TH, PKFY-MS100VKM-ER1.TH and PKFY-MS100VKM-ETR1.TH have been added in REVISED EDITION-A.

OCH824 is void.

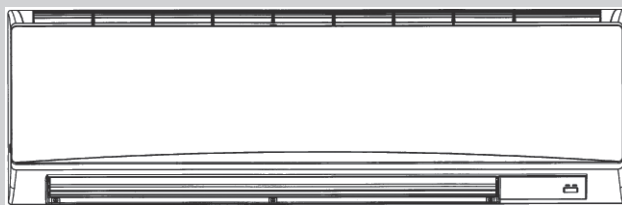
INDOOR UNIT

 Model name
 indication

CONTENTS

TECHNICAL CHANGES	2
1. SAFETY PRECAUTION	3
2. PART NAMES	9
3. SPECIFICATION	10
4. OUTLINES AND DIMENSIONS	13
5. WIRING DIAGRAM	14
6. REFRIGERANT SYSTEM DIAGRAM	15
7. TROUBLESHOOTING	16
8. DISASSEMBLY PROCEDURE	25
9. REMOTE CONTROLLER	30





PARTS CATALOG (OCB824)

TECHNICAL CHANGES

PKFY-MS63VKM-E.TH → PKFY-MS63VKM-ER1.TH
PKFY-MS63VKM-ET.TH → PKFY-MS63VKM-ETR1.TH
PKFY-MS100VKM-E.TH → PKFY-MS100VKM-ER1.TH
PKFY-MS100VKM-ET.TH → PKFY-MS100VKM-ETR1.TH

The color of the front panel has been changed.

MEANINGS OF SYMBOLS DISPLAYED ON THE UNIT

	WARNING (Risk of fire)	This mark is for R32 refrigerant only. Refrigerant type is written on nameplate of outdoor unit. In case that refrigerant type is R32, this unit uses a flammable refrigerant. If refrigerant leaks and comes in contact with fire or heating part, it will create harmful gas and there is risk of fire.
		Read the OPERATION MANUAL carefully before operation.
		Service personnel are required to carefully read the OPERATION MANUAL and INSTALLATION MANUAL before operation.
		Further information is available in the OPERATION MANUAL, INSTALLATION MANUAL, and the like.

1-1. ALWAYS OBSERVE FOR SAFETY

Before obtaining access to terminal, all supply circuits must be disconnected.

1-2. CAUTIONS RELATED TO REFRIGERANT

Caution for units utilizing refrigerant R32

Use new refrigerant pipes.

In case of using the existing pipes for R22, be careful with the following.

- Be sure to clean the pipes and make sure that the insides of the pipes are clean.
- Change flare nut to the one provided with this product. Use a newly flared pipe.
- Avoid using thin pipes.
- In case of reconnecting the refrigerant pipes after detaching, make the flared part of pipe re-fabricated.

Make sure that the inside and outside of refrigerant piping is clean and it has no contaminants such as sulfur, oxides, dirt, shaving particles, etc., which are hazard to refrigerant cycle. In addition, use pipes with specified thickness.

Contamination inside refrigerant piping can cause deterioration of refrigerant oil, etc.

Store the piping indoors, and keep both ends of the piping sealed until just before brazing. (Leave elbow joints, etc. in their packaging.)

If dirt, dust or moisture enters into refrigerant cycle, that can cause deterioration of refrigerant oil or malfunction of compressor.

The refrigerant oil applied to flare and flange connections must be ester oil, ether oil or alkylbenzene oil in a small amount.

If large amount of mineral oil enters, that can cause deterioration of refrigerant oil, etc.

Charge refrigerant from liquid phase of gas cylinder.

If the refrigerant is charged from gas phase, composition change may occur in refrigerant and the efficiency will be lowered.

Use a vacuum pump with a reverse flow check valve.

Vacuum pump oil may flow back into refrigerant cycle and that can cause deterioration of refrigerant oil, etc.

Use the following tools specifically designed for use with R32 refrigerant.

The following tools are necessary to use R32/R410A refrigerant.

Tools for R32	
Gauge manifold	Flare tool
Charge hose	Size adjustment gauge
Gas leak detector	Vacuum pump adaptor
Torque wrench	Electronic refrigerant charging scale

Handle tools with care.

If dirt, dust or moisture enters into refrigerant cycle, that can cause deterioration of refrigerant oil or malfunction of compressor.

Do not use a charging cylinder.

If a charging cylinder is used, the composition of refrigerant will change and the efficiency will be lowered.

Use the specified refrigerant only.

Never use any refrigerant other than that specified.

Doing so may cause a burst, an explosion, or fire when the unit is being used, serviced, or disposed of.

Correct refrigerant is specified on name plate of outdoor unit.

If other refrigerant (R22, etc.) is used, chlorine in refrigerant can cause deterioration of refrigerant oil, etc. We will not be held responsible for mechanical failure, system malfunction, unit breakdown or accidents caused by failure to follow the instructions.

Ventilate the room if refrigerant leaks during operation. If refrigerant comes into contact with a flame, poisonous gases will be released.

[1] Warning for service

- (1) Do not alter the unit.
- (2) For installation and relocation work, follow the instructions in the Installation Manual and use tools and pipe components specifically made for use with refrigerant specified in the outdoor unit installation manual.
- (3) Ask a dealer or an authorized technician to install, relocate and repair the unit.
- (4) This unit should be installed in rooms which exceed the floor space specified in outdoor unit installation manual. Refer to outdoor unit installation manual.
- (5) Install the indoor unit at least 2.5 m above floor or grade level.
For appliances not accessible to the general public.
- (6) Refrigerant pipes connection shall be accessible for maintenance purposes.
- (7) If the air conditioner is installed in a small room or closed room, measures must be taken to prevent the refrigerant concentration in the room from exceeding the safety limit in the event of refrigerant leakage. Should the refrigerant leak and cause the concentration limit to be exceeded, hazards due to lack of oxygen in the room may result.
- (8) Keep gas-burning appliances, electric heaters, and other fire sources (ignition sources) away from the location where installation, repair, and other air conditioner work will be performed.
If refrigerant comes into contact with a flame, poisonous gases will be released.
- (9) When installing or relocating, or servicing the air conditioner, use only the specified refrigerant written on outdoor unit to charge the refrigerant lines.
Do not mix it with any other refrigerant and do not allow air to remain in the lines.
If air is mixed with the refrigerant, then it can be the cause of abnormal high pressure in the refrigerant line, and may result in an explosion and other hazards.
- (10) After installation has been completed, check for refrigerant leaks. If refrigerant leaks into the room and comes into contact with the flame of a heater or portable cooking range, poisonous gases will be released.
- (11) Do not use low temperature solder alloy in case of brazing the refrigerant pipes.
- (12) When performing brazing work, be sure to ventilate the room sufficiently. Make sure that there are no hazardous or flammable materials nearby.
When performing the work in a closed room, small room, or similar location, make sure that there are no refrigerant leaks before performing the work.
If refrigerant leaks and accumulates, it may ignite or poisonous gases may be released.
- (13) Do not install the unit in places where refrigerant may build-up or places with poor ventilation such as a semi-basement or a sunken place in outdoor: Refrigerant is heavier than air, and inclined to fall away from the leak source.
- (14) Do not use means to accelerate the defrosting process or to clean, other than those recommended by the manufacturer.
- (15) The appliance shall be stored in a room without continuously operating ignition sources (for example: open flames, an operating gas appliance or an operating electric heater).
- (16) Do not pierce or burn.
- (17) Be aware that refrigerants may not contain an odor.
- (18) Pipe-work shall be protected from physical damage.
- (19) The installation of pipe-work shall be kept to a minimum.
- (20) Compliance with national gas regulations shall be observed.
- (21) Keep any required ventilation openings clear of obstruction.
- (22) Servicing shall be performed only as recommended by the manufacturer.
- (23) The appliance shall be stored in a well-ventilated area where the room size corresponds to the room area as specified for operation.
- (24) Maintenance, service and repair operations shall be performed by authorized technician with required qualification.

[2] Cautions for service

- (1) Perform service after recovering the refrigerant left in unit completely.
- (2) Do not release refrigerant in the air.
- (3) After completing service, charge the cycle with specified amount of refrigerant.
- (4) When performing service, install a filter drier simultaneously.
Be sure to use a filter drier for new refrigerant.

[3] Additional refrigerant charge

When charging directly from cylinder

- (1) Check that cylinder for R32/R410A available on the market is a syphon type.
- (2) Charging should be performed with the cylinder of syphon stood vertically. (Refrigerant is charged from liquid phase.)

[4] Cautions for unit using R32 refrigerant

Basic work procedures are the same as those for conventional units using refrigerant R410A. However, pay careful attention to the following points.

(1) Information on servicing

(1-1) Checks on the Area

Prior to beginning work on systems containing flammable refrigerants, safety checks are necessary to ensure that the risk of ignition is minimized.

For repair to the refrigerating systems, (1-3) to (1-7) shall be completed prior to conducting work on the systems.

(1-2) Work Procedure

Work shall be undertaken under a controlled procedure so as to minimize the risk of a flammable gas or vapor being present while the work is being performed.

(1-3) General Work Area

All maintenance staff and others working in the local area shall be instructed on the nature of work being carried out. Work in confined spaces shall be avoided. The area around the workspace shall be sectioned off. Ensure that the conditions within the area have been made safe by control of flammable material.

(1-4) Checking for Presence of Refrigerant

The area shall be checked with an appropriate refrigerant detector prior to and during work, to ensure the technician is aware of potentially toxic or flammable atmospheres. Ensure that the leak detection equipment being used is suitable for use with all applicable refrigerants, i.e. non-sparking, adequately sealed or intrinsically safe.

(1-5) Presence of Fire Extinguisher

If any hot work is to be conducted on the refrigeration equipment or any associated parts, appropriate fire extinguishing equipment shall be available to hand.

Have a dry powder or CO₂ fire extinguisher adjacent to the charging area.

(1-6) No Ignition Sources

No person carrying out work in relation to a refrigeration system which involves exposing any pipe work shall use any sources of ignition in such a manner that it may lead to the risk of fire or explosion. All possible ignition sources, including cigarette smoking, should be kept sufficiently far away from the site of installation, repairing, removing and disposal, during which refrigerant can possibly be released to the surrounding space. Prior to work taking place, the area around the equipment is to be surveyed to make sure that there are no flammable hazards or ignition risks. "No Smoking" signs shall be displayed.

(1-7) Ventilated Area

Ensure that the area is in the open or that it is adequately ventilated before breaking into the system or conducting any hot work. A degree of ventilation shall continue during the period that the work is carried out. The ventilation should safely disperse any released refrigerant and preferably expel it externally into the atmosphere.

(1-8) Checks on the Refrigeration Equipment

Where electrical components are being changed, they shall be fit for the purpose and to the correct specification. At all times the manufacturer's maintenance and service guidelines shall be followed. If in doubt, consult the manufacturer's technical department for assistance.

The following checks shall be applied to installations using flammable refrigerants:

- The charge size is in accordance with the room size within which the refrigerant containing parts are installed.
- The ventilation machinery and outlets are operating adequately and are not obstructed.
- Marking to the equipment continues to be visible and legible. Markings and signs that are illegible shall be corrected.
- Refrigeration pipe or components are installed in a position where they are unlikely to be exposed to any substance which may corrode refrigerant containing components, unless the components are constructed of materials which are inherently resistant to being corroded or are suitably protected against being corroded.

(1-9) Checks on Electrical Devices

Repair and maintenance to electrical components shall include initial safety checks and component inspection procedures. If a fault exists that could compromise safety, then no electrical supply shall be connected to the circuit until it is satisfactorily dealt with. If the fault cannot be corrected immediately but it is necessary to continue operation, an adequate temporary solution shall be used. This shall be reported to the owner of the equipment so all parties are advised.

Initial safety checks shall include that:

- capacitors are discharged: this shall be done in a safe manner to avoid possibility of sparking;
- no live electrical components and wiring are exposed while charging, recovering or purging the system;
- there is continuity of earth bonding

(2) Repairs to Sealed Components

(2-1) During repairs to sealed components, all electrical supplies shall be disconnected from the equipment being worked upon prior to any removal of sealed covers, etc. If it is absolutely necessary to have an electrical supply to equipment during servicing, then a permanently operating form of leak detection shall be located at the most critical point to warn of a potentially hazardous situation.

(2-2) Particular attention shall be paid to the following to ensure that by working on electrical components, the casing is not altered in such a way that the level of protection is affected. This shall include damage to cables, excessive number of connections, terminals not made to original specification, damage to seals, incorrect fitting of glands, etc.

Ensure that the apparatus is mounted securely.

Ensure that seals or sealing materials have not degraded to the point that they no longer serve the purpose of preventing the ingress of flammable atmospheres.

Replacement parts shall be in accordance with the manufacturer's specifications.

(3) Repair to intrinsically Safe Components

Do not apply any permanent inductive or capacitance loads to the circuit without ensuring that this will not exceed the permissible voltage and current permitted for the equipment in use.

Intrinsically safe components are the only types that can be worked on while live in the presence of a flammable atmosphere. The test apparatus shall be at the correct rating.

Replace components only with parts specified by the manufacturer. Other parts may result in the ignition of refrigerant in the atmosphere from a leak.

(4) Cabling

Check that cabling will not be subject to wear, corrosion, excessive pressure, vibration, sharp edges or any other adverse environmental effects. The check shall also take into account the effects of aging or continual vibration from sources such as compressors or fans.

(5) Detection of Flammable Refrigerants

Under no circumstances shall potential sources of ignition be used in the searching for or detection of refrigerant leaks.

A halide torch (or any other detector using a naked flame) shall not be used.

(6) Leak Detection Methods

Electronic leak detectors may be used to detect refrigerant leaks but, in the case of flammable refrigerants, the sensitivity may not be adequate, or may need re-calibration. (Detection equipment shall be calibrated in a refrigerant-free area.)

Ensure that the detector is not a potential source of ignition and is suitable for the refrigerant used. Leak detection equipment shall be set at a percentage of the LFL of the refrigerant and shall be calibrated to the refrigerant employed, and the appropriate percentage of gas (25% maximum) is confirmed.

Leak detection fluids are suitable for use with most refrigerants but the use of detergents containing chlorine shall be avoided as the chlorine may react with the refrigerant and corrode the copper pipe-work.

If a leak is suspected, all naked flames shall be removed/extinguished.

If a leakage of refrigerant is found which requires brazing, all of the refrigerant shall be recovered from the system, or isolated (by means of shut off valves) in a part of the system remote from the leak. For appliances containing flammable refrigerants, oxygen free nitrogen (OFN) shall then be purged through the system both before and during the brazing process.

(7) Removal and Evacuation

When breaking into the refrigerant circuit to make repairs – or for any other purpose conventional procedures shall be used. However, for flammable refrigerants it is important that best practice is followed since flammability is a consideration. The following procedure shall be adhered to:

- remove refrigerant
- purge the circuit with inert gas
- evacuate
- purge again with inert gas
- open the circuit by cutting or brazing.

The refrigerant charge shall be recovered into the correct recovery cylinders. For appliances containing flammable refrigerants, the system shall be “flushed” with OFN to render the unit safe. This process may need to be repeated several times.

Compressed air or oxygen shall not be used for purging refrigerant systems.

For appliances containing flammable refrigerants, flushing shall be achieved by breaking the vacuum in the system with OFN and continuing to fill until the working pressure is achieved, then venting to atmosphere, and finally pulling down to a vacuum. This process shall be repeated until no refrigerant is within the system. When the final OFN charge is used, the system shall be vented down to atmospheric pressure to enable work to take place. This operation is absolutely vital if brazing operations on the pipe-work are to take place.

Ensure that the outlet for the vacuum pump is not close to any ignition sources and that ventilation is available.

(8) Charging Procedures

In addition to conventional charging procedures, the following requirements shall be followed:

- Ensure that contamination of different refrigerants does not occur when using charging equipment. Hoses or lines shall be as short as possible to minimize the amount of refrigerant contained in them.
- Cylinders shall be kept upright.
- Ensure that the refrigeration system is earthed prior to charging the system with refrigerant.
- Label the system when charging is complete (if not already).
- Extreme care shall be taken not to overfill the refrigeration system.

Prior to recharging the system, it shall be pressure-tested with the appropriate purging gas. The system shall be leak-tested on completion of charging but prior to commissioning. A follow up leak test shall be carried out prior to leaving the site.

(9) Decommissioning

Before carrying out this procedure, it is essential that the technician is completely familiar with the equipment and all its detail. It is recommended good practice that all refrigerants are recovered safely. Prior to the task being carried out, an oil and refrigerant sample shall be taken in case analysis is required prior to re-use of reclaimed refrigerant. It is essential that electrical power is available before the task is commenced.

Continued to the next page

- a) Become familiar with the equipment and its operation.
- b) Isolate system electrically.
- c) Before attempting the procedure, ensure that:
 - mechanical handling equipment is available, if required, for handling refrigerant cylinders;
 - all personal protective equipment is available and being used correctly;
 - the recovery process is supervised at all times by a competent person;
 - recovery equipment and cylinders conform to the appropriate standards.
- d) Pump down refrigerant system, if possible.
- e) If a vacuum is not possible, make a manifold so that refrigerant can be removed from various parts of the system.
- f) Make sure that cylinder is situated on the scales before recovery takes place.
- g) Start the recovery machine and operate in accordance with manufacturer's instructions.
- h) Do not overfill cylinders. (No more than 80 % volume liquid charge).
- i) Do not exceed the maximum working pressure of the cylinder, even temporarily.
- j) When the cylinders have been filled correctly and the process completed, make sure that the cylinders and the equipment are removed from site promptly and all isolation valves on the equipment are closed off.
- k) Recovered refrigerant shall not be charged into another refrigeration system unless it has been cleaned and checked.

(10) Labelling

Equipment shall be labelled stating that it has been de-commissioned and emptied of refrigerant. The label shall be dated and signed. For appliances containing flammable refrigerants, ensure that there are labels on the equipment stating the equipment contains flammable refrigerant.

(11) Recovery

When removing refrigerant from a system, either for servicing or decommissioning, it is recommended good practice that all refrigerants are removed safely. When transferring refrigerant into cylinders, ensure that only appropriate refrigerant recovery cylinders are employed. Ensure that the correct number of cylinders for holding the total system charge are available. All cylinders to be used are designated for the recovered refrigerant and labelled for that refrigerant (i.e. special cylinders for the recovery of refrigerant). Cylinders shall be complete with pressure-relief valve and associated shut-off valves in good working order. Empty recovery cylinders are evacuated and, if possible, cooled before recovery occurs.

The recovery equipment shall be in good working order with a set of instructions concerning the equipment that is at hand and shall be suitable for the recovery of all appropriate refrigerants including, when applicable, flammable refrigerants. In addition, a set of calibrated weighing scales shall be available and in good working order. Hoses shall be complete with leak-free disconnect couplings and in good condition. Before using the recovery machine, check that it is in satisfactory working order, has been properly maintained and that any associated electrical components are sealed to prevent ignition in the event of a refrigerant release. Consult manufacturer if in doubt.

The recovered refrigerant shall be returned to the refrigerant supplier in the correct recovery cylinder, and the relevant waste transfer note arranged. Do not mix refrigerants in recovery units and especially not in cylinders. If compressors or compressor oils are to be removed, ensure that they have been evacuated to an acceptable level to make certain that flammable refrigerant does not remain within the lubricant. The evacuation process shall be carried out prior to returning the compressor to the suppliers. Only electric heating to the compressor body shall be employed to accelerate this process. When oil is drained from a system, it shall be carried out safely.

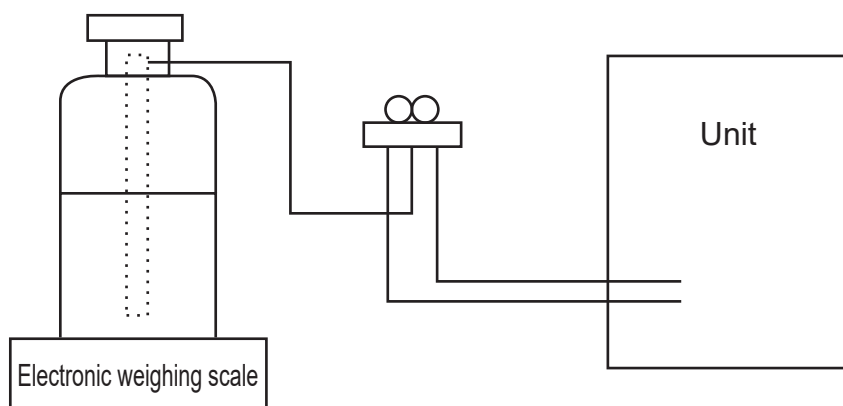

[5] Service tools

Use the below service tools as exclusive tools for R32 refrigerant.

No.	Tool name	Specifications
1	Gauge manifold	· Only for R32
		· Use the existing fitting specifications. (UNF1/2)
		· Use high-tension side pressure of 5.3MPa·G or over.
2	Charge hose	· Only for R32
		· Use pressure performance of 5.09MPa·G or over.
3	Electronic weighing scale	—
4	Gas leak detector	· Use the detector for R134a, R407C, R410A or R32.
5	Adaptor for reverse flow check	· Attach on vacuum pump.
6	Refrigerant cylinder adaptor	—
7	Refrigerant cylinder	· Only for R32
		· Cylinder with syphon
8	Refrigerant recovery equipment	—

2

PART NAMES

2-1. Indoor unit

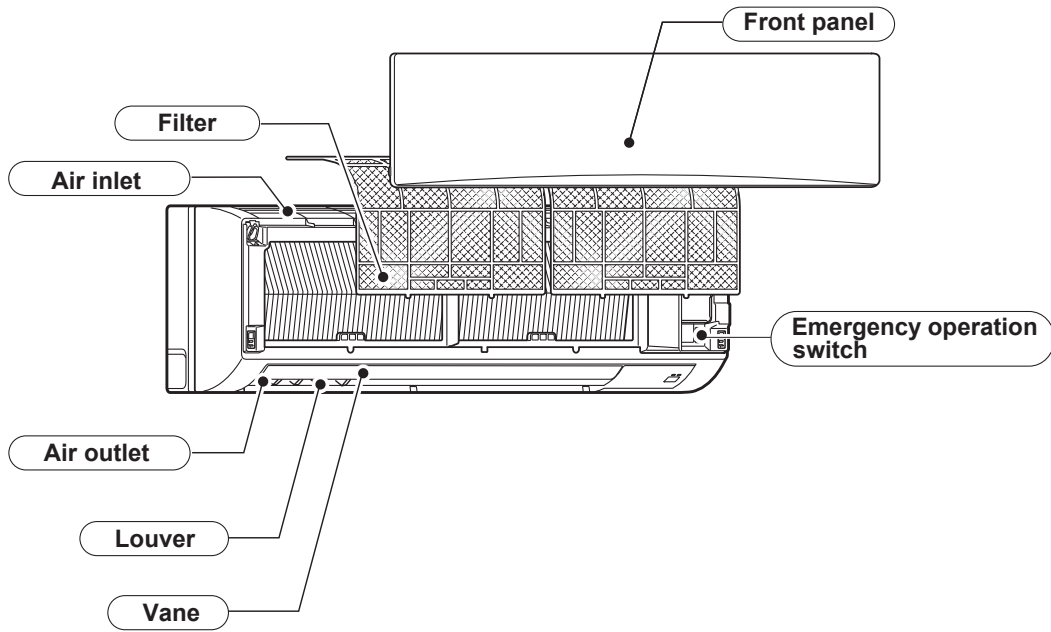

3-1. Specifications

Model		PKFY-MS63VKM-E.TH PKFY-MS63VKM-ET.TH	PKFY-MS100VKM-E.TH PKFY-MS100VKM-ET.TH		
Power source		1-phase 220-230-240 V 50 Hz, 1-phase 220-230 V 60 Hz			
Cooling capacity (Nominal)	*1	kW	7.1	11.2	
	*1	kcal/h	6,100	9,600	
	*1	Btu/h	24,200	38,200	
	*2	kcal/h	6,300	10,000	
	Power input *4	kW	0.05	0.08	
	Current input *4	A	0.37	0.58	
Heating capacity (Nominal)	*3	kW	8.0	12.5	
	*3	kcal/h	6,900	10,800	
	*3	Btu/h	27,300	42,600	
	Power input	kW	0.04	0.07	
	Current input	A	0.30	0.51	
External finish		Plastic, MUNSELL (1.0Y 9.2/0.2)			
External dimension H x W x D		mm	365 × 1170 × 295		
		in	14-3/8" × 46-1/16" × 11-5/8"		
Net weight		kg (lb)	21 (46)		
Heat exchanger		Cross fin (Aluminum fin and copper tube)			
Fan	Type x Quantity		Line flow fan × 1		
	External static press	Pa	0		
		mmH ₂ O	0		
	Motor type		DC motor		
	Motor output	kW	0.069		
	Driving mechanism		Direct-drive		
	Airflow rate (Low-High)	m ³ /min	16 - 20	20 - 26	
		L/s	267 - 333	333 - 433	
cfm		565 - 706	706 - 918		
Noise level (Low-High) (measured in anechoic room)		dB <A>	39 - 42	41 - 49	
Insulation material		Polyethylene sheet			
Air filter		PP honeycomb			
Protection device		Fuse			
Refrigerant control device		LEV			
Connectable outdoor unit		R32 CITY MULTI			
Diameter of refrigerant pipe	Liquid (R32)	mm (in)	ø9.52 (ø3/8") Flare		
	Gas (R32)	mm (in)	ø15.88 (ø5/8") Flare		
Field drain pipe size		mm (in)	I.D. 16mm (5/8")		
Standard attachment	Document Accessory	Installation Manual, Instruction Book			
Optional parts	Drain pump kit	PAC-SK19DM-E			
Remarks		Details on foundation work, insulation work, electrical wiring, power source switch, and other items shall be referred to the Installation Manual.			

*1 Nominal cooling conditions

Indoor: 27°CDB/19°CWB (81°FDB/66°FWB)
 Outdoor: 35°CDB (95°FDB)
 Pipe length: 7.5 m (24-9/16 ft)
 Level difference: 0 m (0 ft)

*2 Nominal cooling conditions

27°CDB/19.5°CWB (81°FDB/67°FWB)
 35°CDB (95°FDB)
 5 m (16-3/8 ft)
 0 m (0 ft)

*3 Nominal heating conditions Unit converter

20°CDB (68°FDB)
 7°CDB/6°CWB (45°FDB/43°FWB)
 7.5 m (24-9/16 ft)
 0 m (0 ft)

*4 Electrical characteristic of cooling are included optional drain - pump.

Notes:

• Nominal conditions *1, *3 are subject to JIS B8615-1.

• Due to continuing improvement, above specification may be subject to change without notice.

• See the following for unit conversion: kcal/h = kW × 860, Btu/h = kW × 3,412, cfm = m³/min × 35.31, lb = kg × 0.4536

Above specification data is subject to rounding variation.

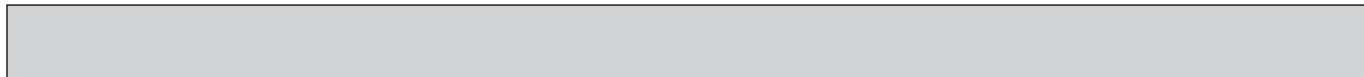

Model			PKFY-MS63VKM-ER1.TH PKFY-MS63VKM-ETR1.TH	PKFY-MS100VKM-ER1.TH PKFY-MS100VKM-ETR1.TH	
Power source			1-phase 220-230-240 V 50 Hz, 1-phase 220-230 V 60 Hz		
Cooling capacity (Nominal)	*1	kW	7.1	11.2	
	*1	kcal/h	6,100	9,600	
		Btu/h	24,200	38,200	
	*2	kcal/h	6,300	10,000	
	Power input *4	kW	0.05	0.08	
	Current input *4	A	0.37	0.58	
Heating capacity (Nominal)	*3	kW	8.0	12.5	
	*3	kcal/h	6,900	10,800	
		Btu/h	27,300	42,600	
	Power input	kW	0.04	0.07	
	Current input	A	0.30	0.51	
External finish			Plastic, MUNSELL (0.7PB 9.2/0.4)		
External dimension H x W x D		mm	365 × 1170 × 295		
		in	14-3/8" × 46-1/16" × 11-5/8"		
Net weight		kg (lb)	21 (46)		
Heat exchanger			Cross fin (Aluminum fin and copper tube)		
Fan	Type x Quantity		Line flow fan × 1		
	External static press	Pa	0		
		mmH ₂ O	0		
	Motor type		DC motor		
	Motor output	kW	0.069		
	Driving mechanism		Direct-drive		
	Airflow rate (Low-High)	m ³ /min	16 - 20	20 - 26	
		L/s	267 - 333	333 - 433	
cfm		565 - 706	706 - 918		
Noise level (Low-High) (measured in anechoic room)		dB <A>	39 - 42	41 - 49	
Insulation material			Polyethylene sheet		
Air filter			PP honeycomb		
Protection device			Fuse		
Refrigerant control device			LEV		
Connectable outdoor unit			R32 CITY MULTI		
Diameter of refrigerant pipe	Liquid (R32)	mm (in)	ø9.52 (ø3/8") Flare		
	Gas (R32)	mm (in)	ø15.88 (ø5/8") Flare		
Field drain pipe size		mm (in)	I.D. 16mm (5/8")		
Standard attachment	Document	Installation Manual, Instruction Book			
	Accessory				
Optional parts	Drain pump kit	PAC-SL48DM-E			
Remarks			Details on foundation work, insulation work, electrical wiring, power source switch, and other items shall be referred to the Installation Manual.		

*1 Nominal cooling conditions

Indoor: 27°CDB/19°CWB (81°FDB/66°FWB)
 Outdoor: 35°CDB (95°FDB)
 Pipe length: 7.5 m (24-9/16 ft)
 Level difference: 0 m (0 ft)

*2 Nominal cooling conditions

27°CDB/19.5°CWB (81°FDB/67°FWB)
 35°CDB (95°FDB)
 5 m (16-3/8 ft)
 0 m (0 ft)

*3 Nominal heating conditions Unit converter

20°CDB (68°FDB)
 7°CDB/6°CWB (45°FDB/43°FWB)
 7.5 m (24-9/16 ft)
 0 m (0 ft)

*4 Electrical characteristic of cooling are included optional drain - pump.

Notes:

- Nominal conditions *1, *3 are subject to JIS B8615-1.
- Due to continuing improvement, above specification may be subject to change without notice.
- See the following for unit conversion: kcal/h = kW × 860, Btu/h = kW × 3,412, cfm = m³/min × 35.31, lb = kg × 0.4536
- Above specification data is subject to rounding variation.

3-2. Electrical parts specifications

Service Ref.	Symbol	PKFY-MS63VKM-E(R1).TH PKFY-MS63VKM-ET(R1).TH	PKFY-MS100VKM-E(R1).TH PKFY-MS100VKM-ET(R1).TH
Parts name			
Room temperature thermistor	TH21	Resistance 0°C/15 kΩ, 10°C/9.6 kΩ, 20°C/6.3 kΩ, 25°C/5.4 kΩ, 30°C/4.3 kΩ, 40°C/3.0 kΩ	
Liquid pipe thermistor	TH22	Resistance 0°C/15 kΩ, 10°C/9.6 kΩ, 20°C/6.3 kΩ, 25°C/5.4 kΩ, 30°C/4.3 kΩ, 40°C/3.0 kΩ	
Gas pipe thermistor	TH23 TH24	Resistance 0°C/15 kΩ, 10°C/9.6 kΩ, 20°C/6.3 kΩ, 25°C/5.4 kΩ, 30°C/4.3 kΩ, 40°C/3.0 kΩ	
Fuse (Indoor controller board)	FUSE	250 V 3.15 A	
Fan motor	MF	8-Pole Output 69 W / RCOJ56-AC	
Vane motor	MV	MSBPC20 DC12 V	
Linear expansion valve	LEV	PAM-B40YGME DC 12 V	PAM-B80YGME DC 12 V
Power supply terminal block	TB2	(L, N, ⊕) 250 V 20 A	
Transmission terminal block	TB5	(M1, M2, S) 250 V 20 A	
MA remote controller terminal block	TB15	(1, 2) 250 V 10 A	

3-3. Sound levels

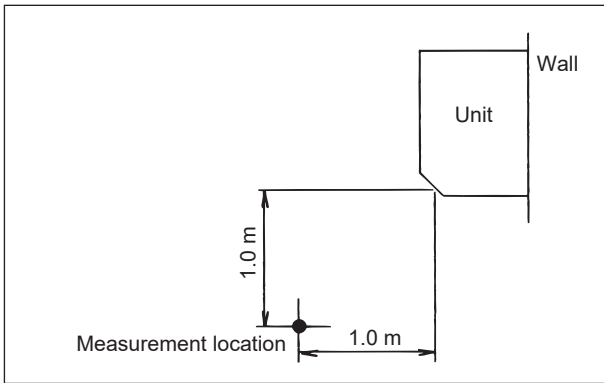

Sound level at anechoic room: Low-High

	Sound level dB (A)
PKFY-MS63VKM-E(R1)/-ET(R1).TH	39 - 42
PKFY-MS100VKM-E(R1)/-ET(R1).TH	41 - 49

* Measured in anechoic room.

3-4. NC curves

PKFY-MS63VKM-E(R1)/-ET(R1).TH

External static pressure: 0Pa
Power source: 220, 230, 240V, 50Hz/220V, 60Hz

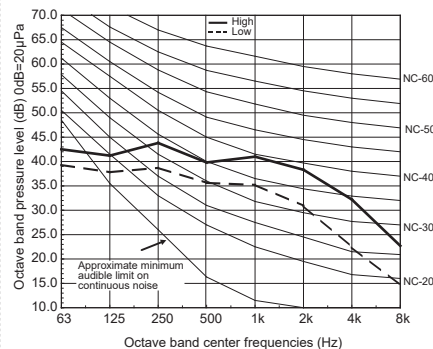

PKFY-MS100VKM-E(R1)/-ET(R1).TH

External static pressure: 0Pa
Power source: 220, 230, 240V, 50Hz/220V, 60Hz

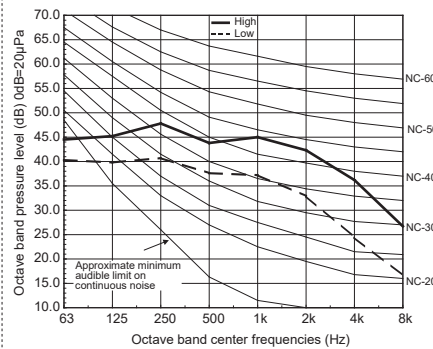

SYMBOL	NAME	SYMBOL	NAME
I.B	INDOOR CONTROLLER BOARD	TH23	THERMISTOR PIPE TEMP. DETECTION / GAS1 (0°C/15kΩ, 25°C/5.4kΩ)
CN32	CONNECTOR REMOTE SWITCH	TH24	PIPE TEMP. DETECTION / GAS2 (0°C/15kΩ, 25°C/5.4kΩ)
CN51	CENTRALLY CONTROL	A.B	ADDRESS BOARD
CN52	REMOTE INDICATION	SWA	SWITCH FAN SPEED SELECTOR
CN105	IT TERMINAL	SW1	MODE SELECTION
BZ1	BUZZER	SW11	ADDRESS SETTING 1s DIGIT
F1	FUSE (T3.15AL 250V)	SW12	ADDRESS SETTING 10s DIGIT
SW2	SWITCH CAPACITY CODE	SW14	BRANCH No.
SW3	MODE SELECTION	S.B	SWITCH BOARD
SW22	PAIR NO. SETTING	SWE1	EMERGENCY OPERATION(HEAT)
SWE	DRAIN PUMP(TEST MODE)	SWE2	EMERGENCY OPERATION(COOL)
LEV	LINEAR EXPANSION VALVE	W.B	PCB FOR WIRELESS REMOTE CONTROLLER
MF	FAN MOTOR	LED1	LED(OPERATION INDICATOR : GREEN)
MV	VANE MOTOR	LED2	LED(PREPARATION FOR HEATING : ORANGE)
TB2	TERMINAL POWER SUPPLY	REC1	RECEIVING UNIT
TB5	BLOCK TRANSMISSION	D.P	DRAIN PUMP KIT (OPTIONAL PARTS)
TB15	BLOCK MA-REMOTE CONTROLLER	DP	DRAIN PUMP
TH21	THERMISTOR ROOM TEMP. DETECTION (0°C/15kΩ, 25°C/5.4kΩ)	FS	DRAIN FLOAT SWITCH
TH22	THERMISTOR PIPE TEMP. DETECTION / LIQUID (0°C/15kΩ, 25°C/5.4kΩ)		

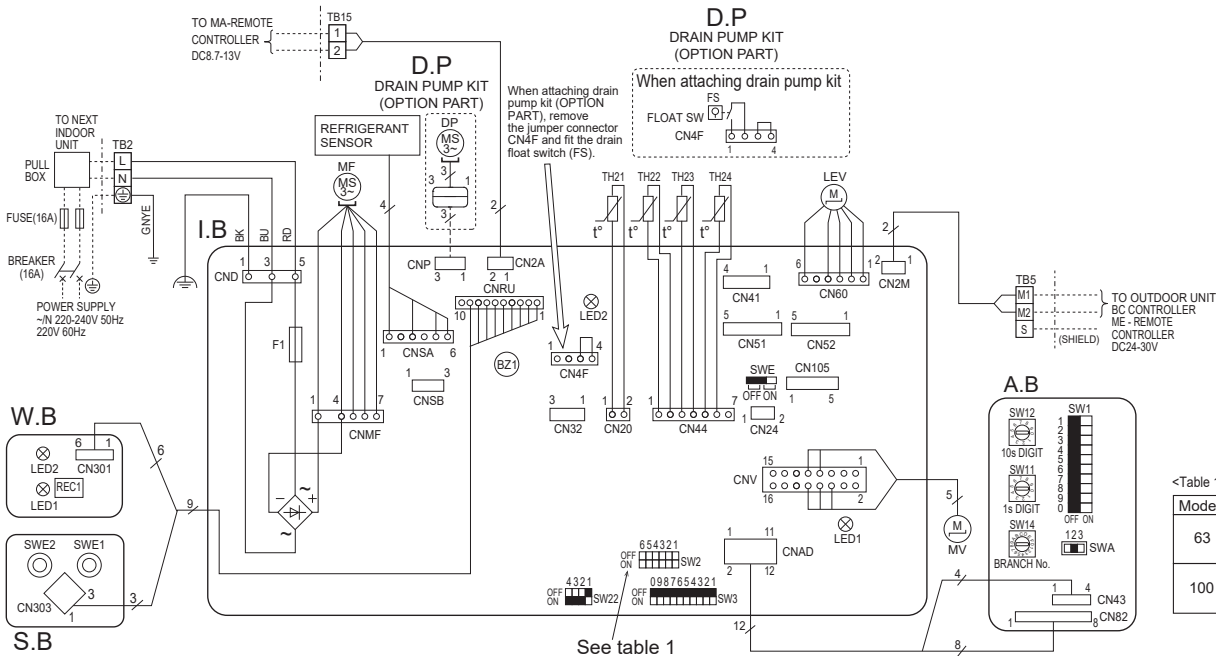

LED on indoor board for service

Mark	Meaning	Function
LED1	Main power supply	Main power supply (Indoor unit:220-240V AC) Power on → lamp is lit
LED2	Power supply for MA-Remote controller	Power supply for MA-Remote controller on → lamp is lit

NOTES:

- At servicing for outdoor unit, always follow the wiring diagram of outdoor unit.
- In case of using MA-Remote controller, please connect to TB15.
(Remote controller wire is non-polar.)
- In case of using M-NET, please connect to TB5. (Transmission line is non-polar.)
- Symbol [S] of TB5 is the shield wire connection.
- Symbols used in wiring diagram are, : terminal block, : connector.
- The setting of the SW2 dip switches differs in the capacity. For the detail, see table 1.
- The black square (■) in the wiring diagram indicates a switch position.

6

REFRIGERANT SYSTEM DIAGRAM

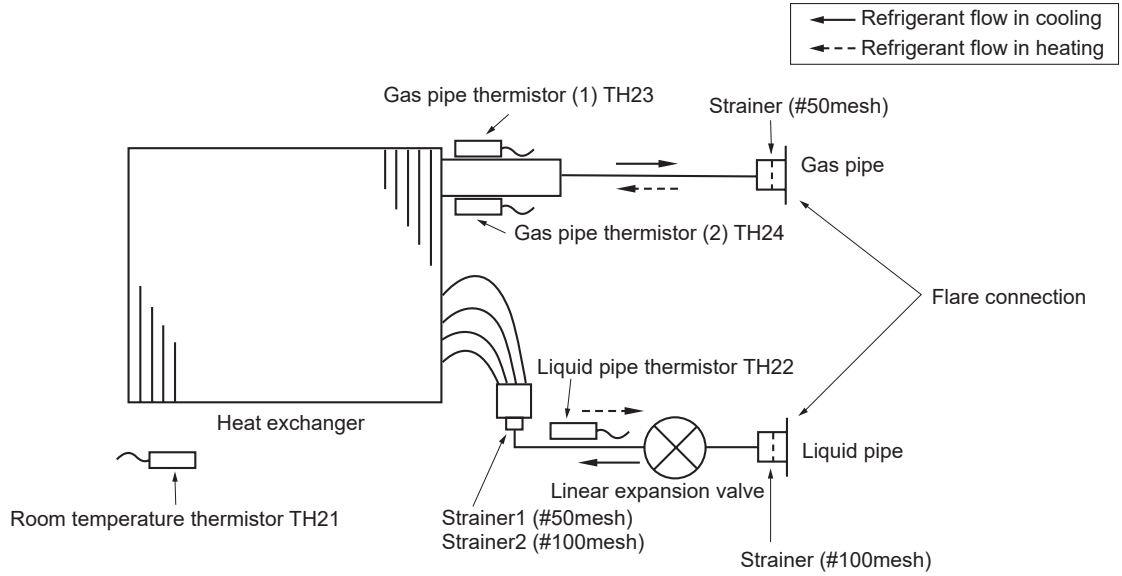

Unit: mm (inch)

Gas pipe	ø15.88 (5/8)
Liquid pipe	ø9.52 (3/8)

7-1. COUNTERMEASURES FOR ERROR DURING TEST RUN

If a problem occurs during test run, a code number will appear on the remote controller (or LED on the outdoor unit), and the air conditioning system will automatically cease operating.

Refer to the connected outdoor unit service manual in order to determine the nature of the abnormality and apply corrective measure.

Check code	Trouble	Detected Unit			Remarks
		Indoor	Outdoor	Remote Controller	
0403	Serial communication error / Model selection SW error		○		Outdoor unit Multi controller board ~ Power board communication trouble
1102	Compressor temperature		○		Check delay code 1202
1300	Low pressure		○		
1302	High pressure		○		Check delay code 1402
1500	Superheat due to low discharge temperature		○		Check delay code 1600
1501	Refrigerant shortage		○		Check delay code 1601
	Closed valve in cooling mode		○		Check delay code 1501
1503	Freeze protection of branch box or indoor unit		○		
1508	4-way valve trouble in heating mode		○		Check delay code 1608
1521	Refrigerant leakage	○			
1522					
2500	Water leakage	○			
2502	Drain overflow protection	○			
2503	Drain sensor abnormality	○			
4100	Compressor current interruption (locked compressor)		○		Check delay code 4350
4114	Fan motor error	○			
4210	Compressor overcurrent interruption		○		
4220	Undervoltage/overvoltage/PAM error/L1 open phase/power synchronization signal error		○		Check delay code 4320
4230	Heat Sink temperature		○		Check delay code 4330
4250	Power module		○		Check delay code 4350
4400	Fan trouble		○		Check delay code 4500
5101	Air inlet thermistor (TH21) open/short	○			
	Compressor temperature thermistor (TH4) open/short		○		Check delay code 1202
5102	Liquid pipe temperature thermistor (TH22) open/short	○			
	Suction pipe temperature thermistor (TH6) open/short		○		Check delay code 1211
5103	Gas pipe temperature thermistor (TH23) open/short	○			
5105	Outdoor liquid pipe temperature thermistor (TH3) open/short		○		Check delay code 1205
5106	Ambient thermistor (TH7) open/short		○		Check delay code 1221
5109	HIC pipe temperature thermistor (TH2) open/short		○		Check delay code 1222
5110	Heat Sink temperature thermistor (TH8) open/short		○		Check delay code 1214
5201	High pressure sensor (63HS)		○		Check delay code 1402
5202	Low pressure sensor (63LS)		○		Check delay code 1400
5558	Refrigerant sensor error	○			
5701	Contact failure of drain float switch	○			
6600	Duplex address error	○	○	○	Only M-NET Remote controller is detected.
6602	Transmission processor hardware error	○	○	○	Only M-NET Remote controller is detected.
6603	Transmission bus BUSY error	○	○	○	Only M-NET Remote controller is detected.
6606	Signal communication error with transmission processor	○	○	○	Only M-NET Remote controller is detected.
6607	No ACK error	○		○	Only M-NET Remote controller is detected. *
6608	No response frame error	○		○	Only M-NET Remote controller is detected. *
6815	MA supervisor remote controller communication error	○			
6831	MA communication receive error (no receive signal)	○		○	Only MA Remote controller is detected.
6832	MA communication send error	○		○	Only MA Remote controller is detected.
6833	MA communication send error	○		○	Only MA Remote controller is detected.
6834	MA communication receive error	○		○	Only MA Remote controller is detected.
7100	Total capacity error		○		
7101	Capacity code error	○	○		
7102	Connecting excessive number of units		○		
7105	Address setting error		○		
7118	Refrigerant leak detection system error		○		
7130	Incompatible unit combination		○		

Note:

When the outdoor unit detects No ACK error/No response error, an object indoor unit is treated as a stop, and not assumed to be abnormal.

*Abnormality for PWFY series

7-2. HOW TO CHECK PARTS

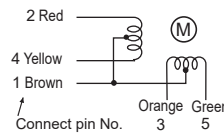
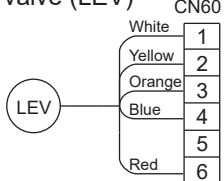
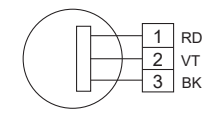
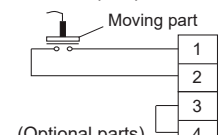
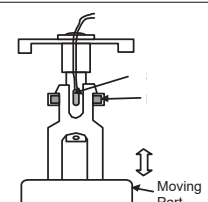
Parts name	Checkpoints																
Room temperature thermistor (TH21) Liquid pipe temperature thermistor (TH22) Gas pipe temperature thermistor (TH23 ,24)	Disconnect the connector then measure the resistance with a multimeter. (At the ambient temperature 10°C - 30°C) <table border="1" style="margin-left: 20px;"> <thead> <tr> <th>Normal</th> <th>Abnormal</th> </tr> </thead> <tbody> <tr> <td>4.3 kΩ~9.6 kΩ</td> <td>Open or short</td> </tr> </tbody> </table> Refer to the next page for the details.	Normal	Abnormal	4.3 kΩ~9.6 kΩ	Open or short												
Normal	Abnormal																
4.3 kΩ~9.6 kΩ	Open or short																
Vane motor (MV) 	Measure the resistance between the terminals with a multimeter. (Coil temperature 20°C) <table border="1" style="margin-left: 20px;"> <thead> <tr> <th colspan="4">Normal</th> <th>Abnormal</th> </tr> </thead> <tbody> <tr> <td>(1)-(2) Brown-Red</td> <td>(1)-(3) Brown-Orange</td> <td>(1)-(4) Brown-Yellow</td> <td>(1)-(5) Brown-Green</td> <td rowspan="2">Open or short</td> </tr> <tr> <td colspan="4" style="text-align: center;">250 Ω ±7%</td> </tr> </tbody> </table>	Normal				Abnormal	(1)-(2) Brown-Red	(1)-(3) Brown-Orange	(1)-(4) Brown-Yellow	(1)-(5) Brown-Green	Open or short	250 Ω ±7%					
Normal				Abnormal													
(1)-(2) Brown-Red	(1)-(3) Brown-Orange	(1)-(4) Brown-Yellow	(1)-(5) Brown-Green	Open or short													
250 Ω ±7%																	
Fan motor (MF)	Refer to 8-1-3.																
Linear expansion valve (LEV) 	Disconnect the connector then measure the resistance valve with a multimeter. (Coil temperature 20°C) <table border="1" style="margin-left: 20px;"> <thead> <tr> <th colspan="4">Normal</th> <th>Abnormal</th> </tr> </thead> <tbody> <tr> <td>(1)-(5) White-Red</td> <td>(2)-(6) Yellow-Red</td> <td>(3)-(5) Orange-Red</td> <td>(4)-(6) Blue-Red</td> <td rowspan="2">Open or short</td> </tr> <tr> <td colspan="4" style="text-align: center;">150 Ω ±10%</td> </tr> </tbody> </table>	Normal				Abnormal	(1)-(5) White-Red	(2)-(6) Yellow-Red	(3)-(5) Orange-Red	(4)-(6) Blue-Red	Open or short	150 Ω ±10%					
Normal				Abnormal													
(1)-(5) White-Red	(2)-(6) Yellow-Red	(3)-(5) Orange-Red	(4)-(6) Blue-Red	Open or short													
150 Ω ±10%																	
Drain pump (DP)  (Optional parts)	① Check if the drain float switch works properly. ② Check if the drain pump works and drains water properly in cooling operation. ③ If no water drains, confirm that the check code 2502 will not be displayed 10 minutes after the operation starts. Note: The drain pump for this model is driven by the internal DC motor, so it is not possible to measure the resistance between the terminals. Normal Red-Black: Input 13 VDC → The pump motor starts to rotate.																
Drain float switch (FS)  (Optional parts)	Measure the resistance between the terminals with a multimeter. <table border="1" style="margin-left: 20px;"> <thead> <tr> <th>State of moving part</th> <th>Normal</th> <th>Abnormal</th> <th>Drain float switch connector terminal</th> </tr> </thead> <tbody> <tr> <td>UP</td> <td>Short</td> <td>Other than short</td> <td>①(+) - ②(-)</td> </tr> <tr> <td>DOWN</td> <td>Open</td> <td>Other than open</td> <td>①(+) - ②(-)</td> </tr> <tr> <td>-</td> <td>Short</td> <td>Other than short</td> <td>③(+) - ④(-)</td> </tr> </tbody> </table> 	State of moving part	Normal	Abnormal	Drain float switch connector terminal	UP	Short	Other than short	①(+) - ②(-)	DOWN	Open	Other than open	①(+) - ②(-)	-	Short	Other than short	③(+) - ④(-)
State of moving part	Normal	Abnormal	Drain float switch connector terminal														
UP	Short	Other than short	①(+) - ②(-)														
DOWN	Open	Other than open	①(+) - ②(-)														
-	Short	Other than short	③(+) - ④(-)														

7-2-1. Thermistor

<Thermistor Characteristic graph>

Thermistors for lower temperature

Room temperature thermistor (TH21)
 Liquid pipe temperature thermistor (TH22)
 Gas pipe temperature thermistor (TH23)
 (TH24)

Thermistor $R_0=15\text{ k}\Omega \pm 3\%$
 Fixed number of $B=3480 \pm 2\%$

$$R_t = 15 \exp \left\{ 3480 \left(\frac{1}{273+t} - \frac{1}{273} \right) \right\}$$

0°C	15 kΩ
10°C	9.6 kΩ
20°C	6.3 kΩ
25°C	5.4 kΩ
30°C	4.3 kΩ
40°C	3.0 kΩ

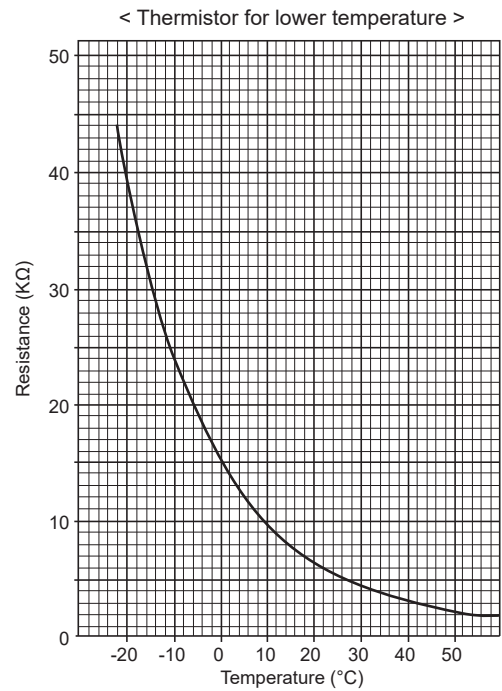

7-2-2. Linear expansion valve

① Operation summary of the linear expansion valve

- Linear expansion valve opens/closes through stepping motor after receiving the pulse signal from the indoor controller board.
- Valve position can be changed in proportion to the number of pulse signal.

<Connection between the indoor controller board and the linear expansion valve>

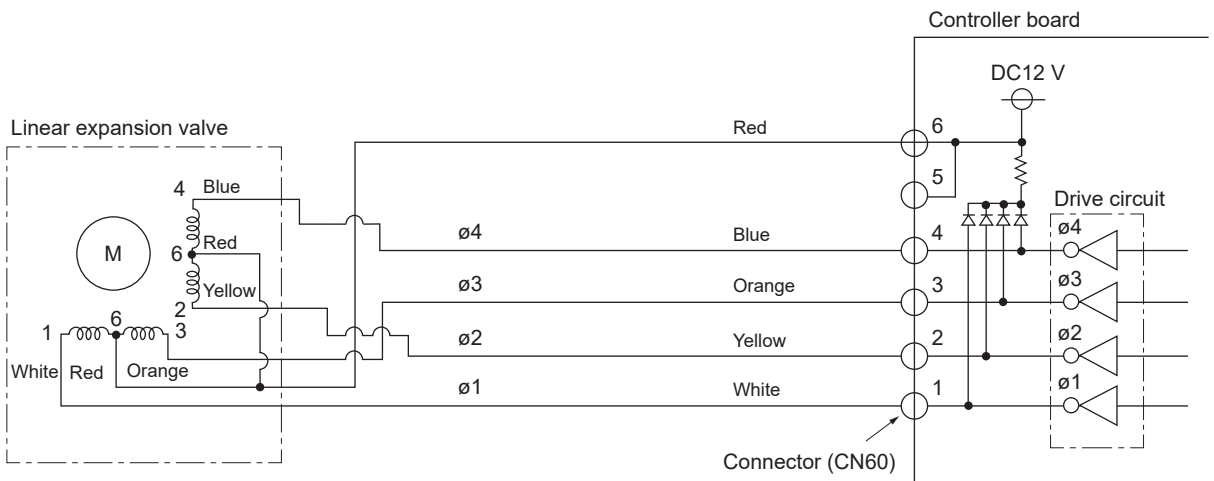

Note: Since the number of the connector at the controller board side and the relay connector are different, follow the color of the lead wire.

<Output pulse signal and the valve operation>

Output (Phase)	Output			
	1	2	3	4
ø1	ON	OFF	OFF	ON
ø2	ON	ON	OFF	OFF
ø3	OFF	ON	ON	OFF
ø4	OFF	OFF	ON	ON

The output pulse shifts in the following order.

Closing a valve: 1 → 2 → 3 → 4 → 1

Opening a valve: 4 → 3 → 2 → 1 → 4

Notes:

- When linear expansion valve operation stops, all output phase become OFF.
- At phase interruption or when phase does not shift in order, motor does not rotate smoothly and motor will lock and vibrate.

② Linear expansion valve operation

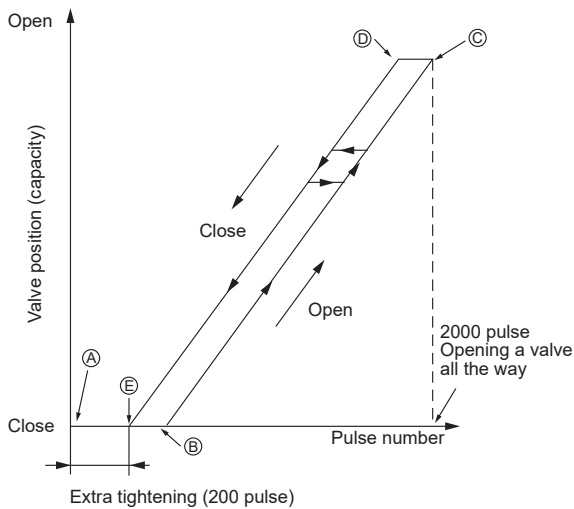

Notes:

- When the power is turned on, 2200 pulse closing valve signal will be sent till it goes to point A in order to define the valve position.
- When the valve moves smoothly, there is no noise or vibration occurring from the linear expansion valves: however, when the pulse number moves from C to A or when the valve is locked, more noise can be heard than in a normal situation.
- Noise can be detected by placing the ear against the screw driver handle while putting the screw driver tip to the linear expansion valve.

③ Troubleshooting

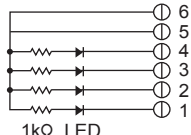
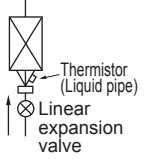
Symptom	Checkpoints	Countermeasures
Operation circuit failure of the micro processor	Disconnect the connector on the controller board, then connect LED for checking.  When power is turned on, pulse signals will output for 10 seconds. There must be some defects in the operation circuit if the LED does not light while the signals are output or keeps lighting even after the signals stop.	Exchange the indoor controller board in case of drive circuit failure.
Linear expansion valve mechanism is locked.	Motor will idle and make a ticking noise when the motor is operated while the linear expansion valve is locked. This ticking sound is the sign of the abnormality.	Exchange the linear expansion valve.
Short or breakage of the motor coil of the linear expansion valve	Measure the resistance between each coil (white-red, yellow-red, orange-red, blue-red) using a multimeter. It is normal if the resistance is in the range of $150 \Omega \pm 10\%$.	Exchange the linear expansion valve.
Valve does not close completely.	To check the linear expansion valve, operate the indoor unit in fan mode and at the same time operate other indoor units in cooling mode, then check the pipe temperature <liquid pipe temperature> of the indoor unit by the outdoor multi controller board operation monitor. During fan operation, linear expansion valve is closed completely and if there is any leaking, detecting temperature of the thermistor will go lower. If the detected temperature is much lower than the temperature indicated in the remote controller, it means the valve is not closed all the way. It is not necessary to exchange the linear expansion valve, if the leakage is small and not affecting normal operation. 	If large amount of refrigerant is leaked, exchange the linear expansion valve.
Wrong connection of the connector or contact failure	Check the color of lead wire and missing terminal of the connector.	Disconnect the connector at the controller board, then check the continuity.

7-2-3. DC Fan motor (fan motor/indoor controller circuit board)

Check method of DC fan motor (fan motor/indoor controller circuit board)

① Notes







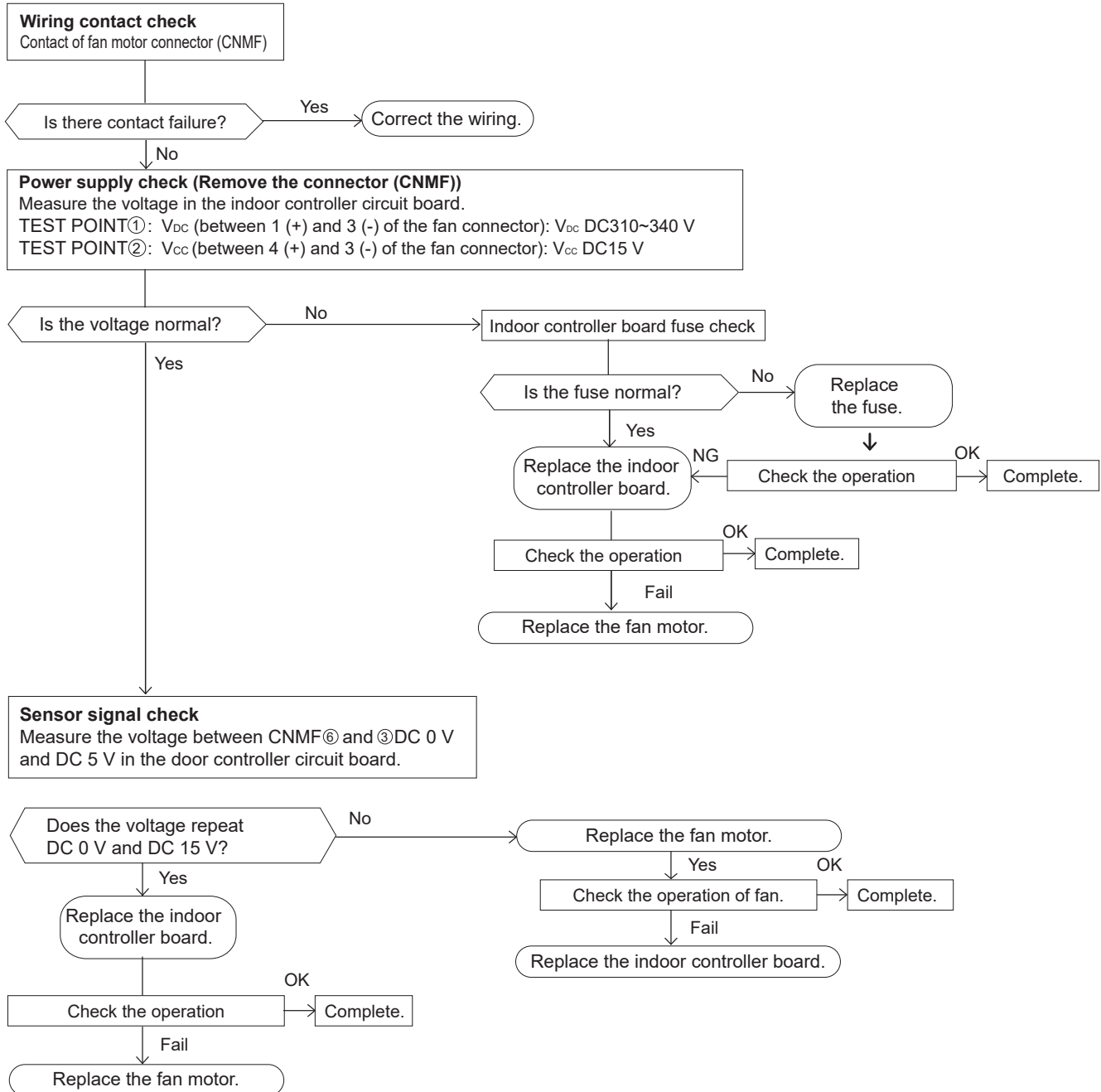





- High voltage is applied to the connector (CNMF) for the fan motor. Pay attention to the service.
- Do not pull out the connector (CNMF) for the motor with the power supply on.
(It causes trouble of the indoor controller circuit board and fan motor.)

② Self check

Symptom: The indoor fan cannot turn around.

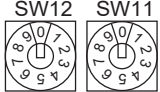

7-3. Function of Dip switch

Switch	Pole	Function	Operation by switch		Effective timing	Remarks																
			ON	OFF																		
SW1 Mode selection	1	Thermistor <Room temperature> position	Built-in remote controller	Indoor unit	Under suspension	<div style="border: 1px solid black; padding: 5px;"> Address board <Initial setting>  </div> <p>NOTE: *1</p> <table border="1" style="font-size: small;"> <tr> <td>SW1-7</td> <td>SW1-8</td> <td>Fan speed</td> </tr> <tr> <td>OFF</td> <td>OFF</td> <td>Extra low</td> </tr> <tr> <td>ON</td> <td>OFF</td> <td>Low</td> </tr> <tr> <td>OFF</td> <td>ON</td> <td>Setting air flow</td> </tr> <tr> <td>ON</td> <td>ON</td> <td>Stop</td> </tr> </table> <p>*2 This function is not available for these models.</p>	SW1-7	SW1-8	Fan speed	OFF	OFF	Extra low	ON	OFF	Low	OFF	ON	Setting air flow	ON	ON	Stop	
	SW1-7	SW1-8	Fan speed																			
	OFF	OFF	Extra low																			
	ON	OFF	Low																			
	OFF	ON	Setting air flow																			
	ON	ON	Stop																			
	2	Filter clogging detection	Provided	Not provided																		
	3	Filter cleaning sign	2,500 hr	100 hr																		
	4	Fresh air intake *2	Not effective	Not effective																		
	5	Switching remote controller display	Thermo ON signal indication	Fan output indication																		
6	Humidifier control	Fan operation at Heating mode	Thermo ON operation at heating mode																			
7	Air flow set in case of heat thermo OFF	Low *1	Extra low *1																			
8		Setting air flow *1	Depends on SW1-7																			
9	Auto restart function	Effective	Not effective																			
10	Power ON/OFF by breaker	Effective	Not effective																			
SW2 Capacity code switch	1~6	<table border="1" style="font-size: x-small;"> <tr> <th>Models</th> <th>SW2</th> </tr> <tr> <td>63</td> <td>  654321 </td> </tr> <tr> <td>100</td> <td>  654321 </td> </tr> </table>	Models	SW2	63	 654321	100	 654321	Before power supply ON	<div style="border: 1px solid black; padding: 5px;"> Indoor controller board <Initial setting> Set for each capacity </div>												
Models	SW2																					
63	 654321																					
100	 654321																					
SW3 Function selection	1	Heat pump/Cooling only	Cooling only	Heat pump	Under suspension	<div style="border: 1px solid black; padding: 5px;"> Indoor controller board <Initial setting>  </div>																
	2	Not used	-	-																		
	3	Not used	-	-																		
	4	Not used	-	-																		
	5	Vane horizontal angle	<table border="1" style="font-size: x-small;"> <tr> <td>SW3-5</td> <td>SW3-6</td> <td>Vane setting</td> </tr> <tr> <td>OFF</td> <td>OFF</td> <td>First setting</td> </tr> <tr> <td>ON</td> <td>OFF</td> <td>Second setting</td> </tr> <tr> <td>OFF</td> <td>ON</td> <td>Third setting</td> </tr> <tr> <td>ON</td> <td>ON</td> <td>Unused</td> </tr> </table>	SW3-5			SW3-6	Vane setting	OFF	OFF	First setting	ON	OFF	Second setting	OFF	ON	Third setting	ON	ON	Unused		
	SW3-5		SW3-6	Vane setting																		
	OFF		OFF	First setting																		
	ON		OFF	Second setting																		
	OFF	ON	Third setting																			
	ON	ON	Unused																			
6																						
7	Changing the opening of linear expansion valve	Effective	Not effective																			
8	Heating 4 degree up	Not effective	Effective																			
9	Not used	-	-																			
10	Not used	-	-																			
SW11 1s digit address setting SW12 10ths digit address setting	Rotary switch	  <p>How to set addresses Example: If address is "3", remain SW12 (for over 10) at "0", and match SW11 (for 1 to 9) with "3".</p>	Before power supply ON	<div style="border: 1px solid black; padding: 5px;"> Address board <Initial setting>  </div>																		
SW14 Branch No. Setting	Rotary switch	 <p>How to set branch numbers SW14 (Series R2 only) Match the indoor unit's refrigerant pipe with the BC controller's end connection number. Remain other than series R2 at "0".</p>		<div style="border: 1px solid black; padding: 5px;"> Address board <Initial setting>  </div>																		



Switch	Pole	Function	Operation by switch		Effective timing	Remarks																																		
			ON	OFF																																				
SW22 Function selection	Switch	<table border="1"> <thead> <tr> <th>Function</th> <th>ON</th> <th>OFF</th> </tr> </thead> <tbody> <tr> <td>1</td> <td>—</td> <td>—</td> </tr> <tr> <td>2</td> <td>—</td> <td>—</td> </tr> <tr> <td>3 Pair No. of wireless remote controller</td> <td colspan="2" rowspan="2">Depends on the combination of SW22-3 and 22-4</td> </tr> <tr> <td>4 Pair No. of wireless remote controller</td> </tr> </tbody> </table> <ul style="list-style-type: none"> To operate each indoor unit by each remote controller when installed 2 indoor units or more are near, Pair No. setting is necessary. Pair No. setting is available with the 4 patterns. Make setting for SW22-3, 22-4 of indoor controller board and the Pair No. of wireless remote controller. <ul style="list-style-type: none"> Pair No. setting is not set necessarily when operating it by one remote controller. ① Setting for indoor unit <ul style="list-style-type: none"> Set SW22-3, 22-4 on the indoor controller board according to the table below. ② Wireless remote controller pair number: <ul style="list-style-type: none"> Setting operation (Fig. 1 A) <ol style="list-style-type: none"> Press the button ① to stop the air conditioner. Press the button ②. Check that function No."1" is displayed, and then press the button ③. The Screen display setting screen will be displayed. (Fig. 2.) Pair No. changing operation (Fig. 2 B) <ol style="list-style-type: none"> Press the button ④. Each time the button ④ is pressed, the pair No.0-3 changes. Press the button ③ to check the setting. Press the button ②. <table border="1"> <thead> <tr> <th colspan="2">Indoor unit SW22</th> <th rowspan="2">Pair No. of wireless remote controller</th> <th rowspan="2"></th> </tr> <tr> <th>SW22-3</th> <th>SW22-4</th> </tr> </thead> <tbody> <tr> <td>ON</td> <td>ON</td> <td>0</td> <td>Initial setting</td> </tr> <tr> <td>OFF</td> <td>ON</td> <td>1</td> <td>—</td> </tr> <tr> <td>ON</td> <td>OFF</td> <td>2</td> <td>—</td> </tr> <tr> <td>OFF</td> <td>OFF</td> <td>3-9</td> <td>—</td> </tr> </tbody> </table>	Function	ON	OFF	1	—	—	2	—	—	3 Pair No. of wireless remote controller	Depends on the combination of SW22-3 and 22-4		4 Pair No. of wireless remote controller	Indoor unit SW22		Pair No. of wireless remote controller		SW22-3	SW22-4	ON	ON	0	Initial setting	OFF	ON	1	—	ON	OFF	2	—	OFF	OFF	3-9	—			<p><Initial setting></p> <p>①</p> <p>②</p> <p>③</p> <p>④</p> <p>Under operation or suspension</p> <p>Fig. 1</p> <p>Fig. 2</p>
		Function	ON	OFF																																				
1	—	—																																						
2	—	—																																						
3 Pair No. of wireless remote controller	Depends on the combination of SW22-3 and 22-4																																							
4 Pair No. of wireless remote controller																																								
Indoor unit SW22		Pair No. of wireless remote controller																																						
SW22-3	SW22-4																																							
ON	ON	0	Initial setting																																					
OFF	ON	1	—																																					
ON	OFF	2	—																																					
OFF	OFF	3-9	—																																					
SWE Test run for Drain pump	Connector	<p>Drain pump and fan are activated simultaneously after the connector SWE is set to ON and turn on the power.</p> <p>OFF ON</p> <p>OFF ON</p> <p>The connector SWE is set to OFF after test run.</p>			Under operation	<p><Initial setting></p> <p>OFF ON</p>																																		



7-4-2. PCB for wireless remote controller (W.B)

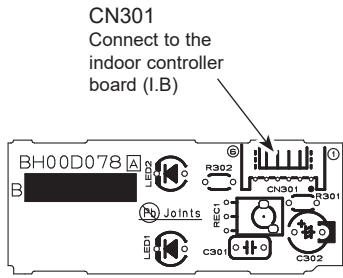

7-4-3. Switch board (S.B)

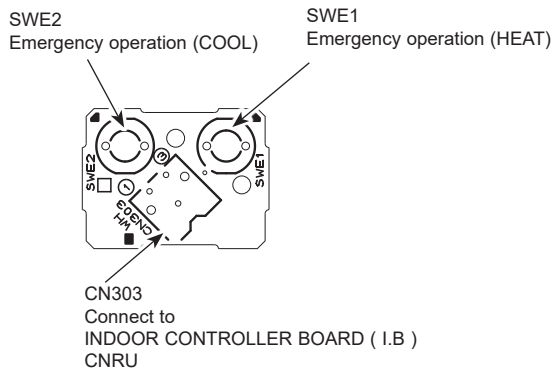

7-4-4. Address board (A.B)

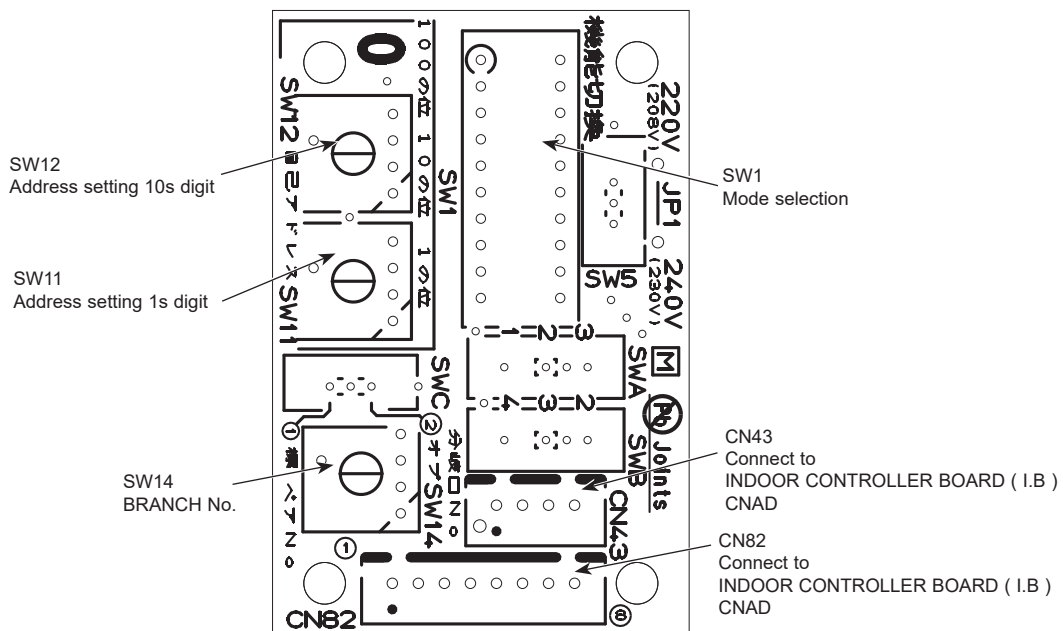

—————> : Indicates the visible parts in the photos/figures.
 - - - - -> : Indicates the invisible parts in the photos/figures.

NOTE: Turn OFF the power supply before disassembly.
 Be careful when removing heavy parts.

OPERATION PROCEDURE

PHOTOS/FIGURES

1. REMOVING THE PANEL

- (1) Press and unlock the knobs on both sides of the front panel and lift the front panel until it is level. Pull the hinges forward to remove the front panel. (See Photo 1)
- (2) Remove 3 screw caps of the panel. Remove 5 screws. (See Photo 1)
- (3) Unfix 3 hooks. (See Figure 1)
- (4) Hold the lower part of both ends of the panel and pull it slightly toward you, and then remove the panel by pushing it upward.
- (5) Remove the screw of the corner box. (See Photo 1)
Remove the corner box.

Photo 1

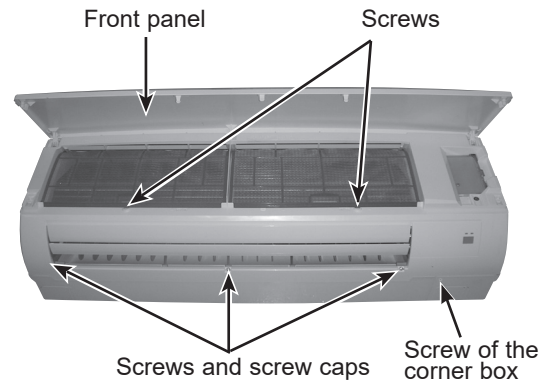
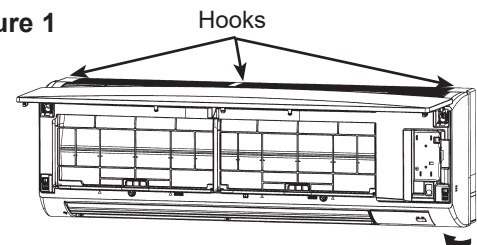

Figure 1



2. REMOVING THE ADDRESS BOARD, THE INDOOR CONTROLLER BOARD, THE WIRELESS CONTROLLER BOARD

- (1) Remove the panel and the corner box. (Refer to procedure 1)
- (2) Remove the screw of address board case. (See Photo 2)
- (3) Disconnect the connectors of address board.
- (4) Remove the front and side electrical box covers (each 1 screw).
- (5) Disconnect the connectors on the indoor controller board. (See Photo 3)
- (6) Remove the switch board holder and open the cover.
- (7) Pull out the indoor controller board toward you then remove the indoor controller board and switch board. (See Photo 3)
- (8) Remove the holder of wireless remote controller board.
- (9) Disconnect the connector of wireless remote controller board and remove the wireless remote controller board from the holder.

Photo 2

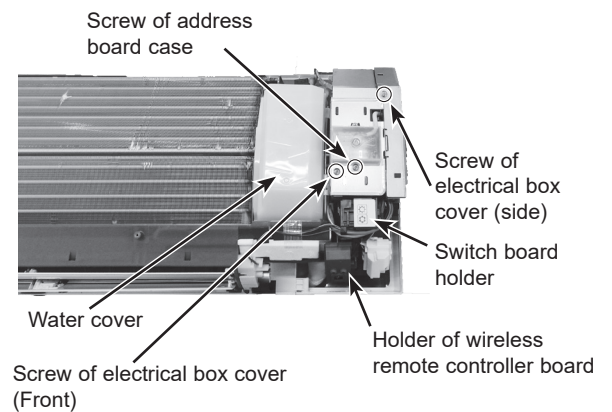
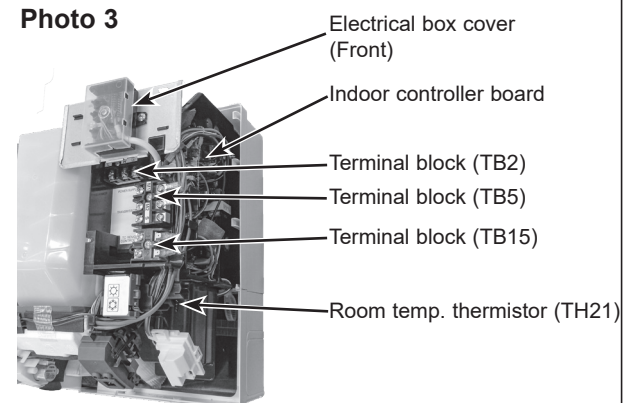

Photo 3





OPERATION PROCEDURE

6. REMOVING THE INDOOR FAN MOTOR AND THE LINE FLOW FAN

- (1) Remove the panel and the corner box. (Refer to procedure 1)
- (2) Remove the electrical box (Refer to procedure 3) and the nozzle assembly (Refer to procedure 4).
- (3) Remove the water cover. (See Photo 2)
- (4) Remove the screw fixing the line flow fan. (See Photo 8)
- (5) Remove 5 screws fixing the motor bed. (See Photo 7)
- (6) Remove the lead wire of pipe thermistor from the hook of motor bed. (See Photo 7)
- (7) Remove the screw fixing motor band. (See Photo 7)
- (8) Remove the motor bed together with fan motor and motor band.
- (9) Remove 3 screws fixing the left side of the heat exchanger. (See Photo 9)
- (10) Lift the heat exchanger, and pull out the line flow fan to the lower-left.

Photo 9

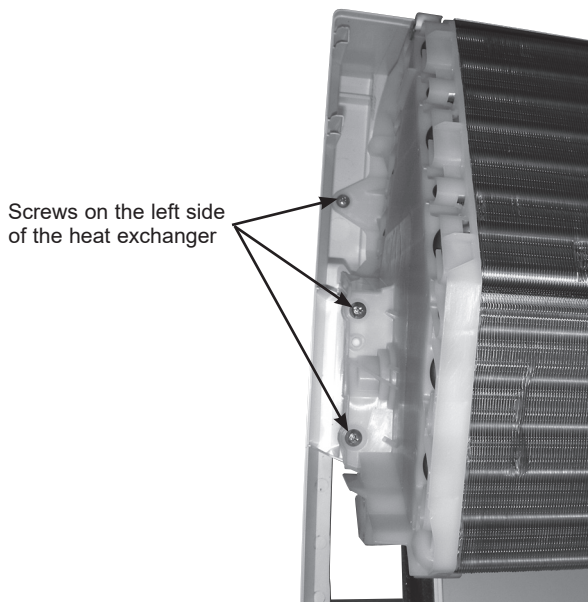

PHOTOS/FIGURES

Photo 7

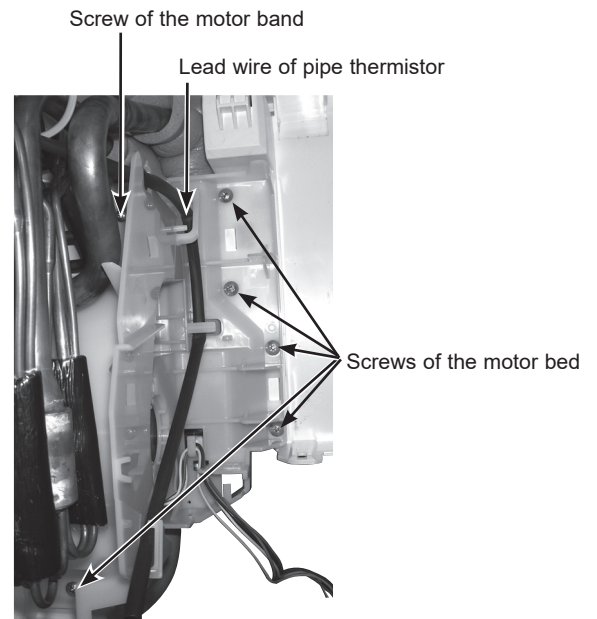
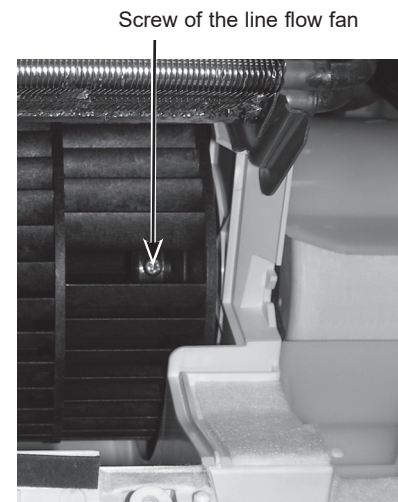

Photo 8



7. REMOVING THE LIQUID PIPE THERMISTOR AND GAS PIPE THERMISTOR

- (1) Remove the panel and the corner box. (Refer to procedure 1)
- (2) Remove the electrical box covers. (Refer to procedure 2)
- (3) Remove the water cover. (See Photo 2)
- (4) Remove the liquid pipe thermistor and gas pipe thermistors.
- (5) Disconnect the connector (CN44) on the indoor controller board. (TH21 and TH23, TH24/CN44)

Photo 10

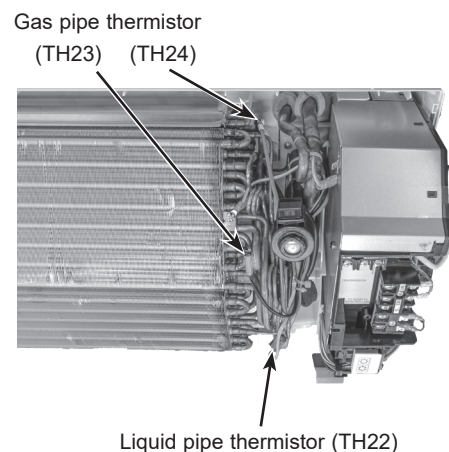



OPERATION PROCEDURE

PHOTOS/FIGURES

8. REMOVING THE HEAT EXCHANGER AND LEV

- (1) Remove the panel and the corner box. (Refer to procedure 1)
- (2) Remove the electrical box (Refer to procedure 3) and the nozzle assembly (Refer to procedure 4).
- (3) Remove the water cover.
- (4) Remove the pipe thermistors (Refer to 7.).
- (5) Disconnect the connector (CN60) on the indoor controller board and the connector for ground wire.
- (6) Remove 3 screws fixing the left side of the heat exchanger. (See Photo 9)
- (7) Remove the heat exchanger with LEV.

Photo 11

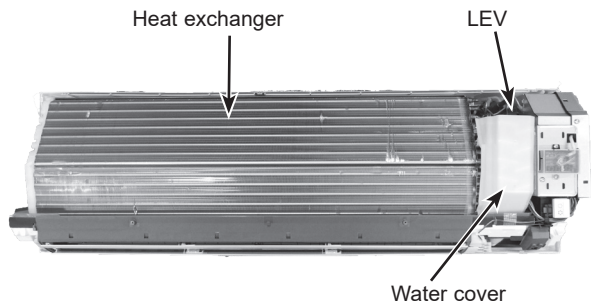
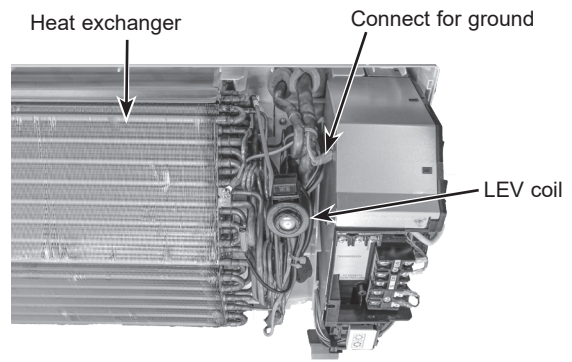

Photo 12



9. REMOVING THE ROOM TEMPERATURE THERMISTOR

- (1) Remove the panel and corner box. (Refer to procedure 1)
- (2) Remove the electrical box covers. (Refer to procedure 2)
- (3) Remove the room temperature thermistor.
- (4) Disconnect the connector (CN20) on the indoor controller board.

Photo 13

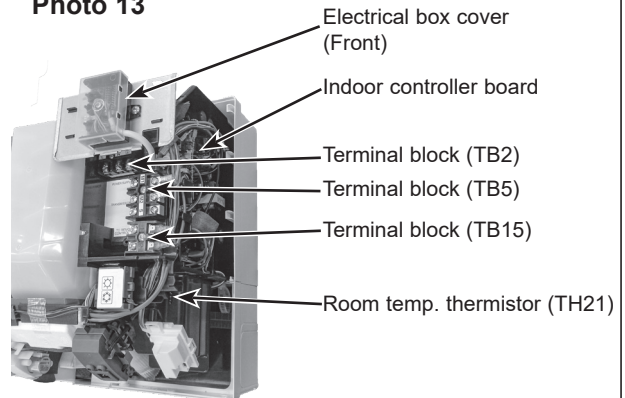

10. REMOVING THE LEV COIL

- (1) Remove the panel and corner box. (Refer to procedure 1)
- (2) Remove the electrical box covers. (Refer to procedure 2)
- (3) Remove the water cover. (See Photo 2)
- (4) Disconnect the LEV coil connector (CN60) on the indoor controller board.
- (5) Rotate the LEV coil and remove it. (See Photo 14)

Photo 14

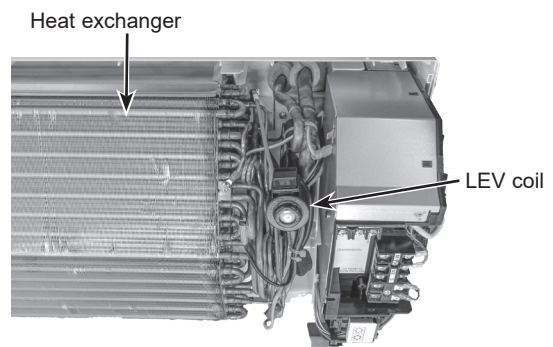

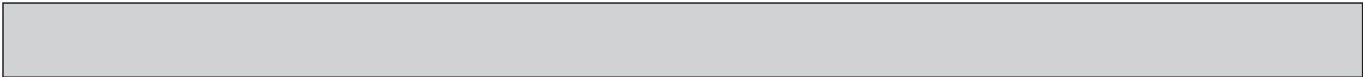

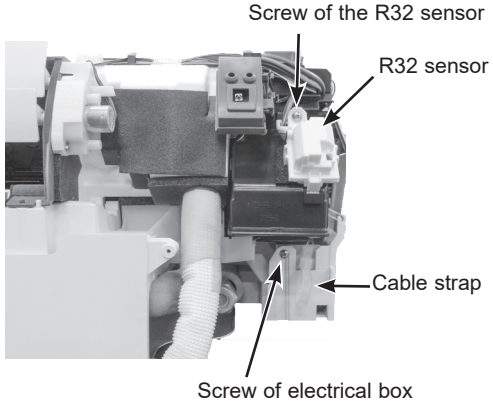
OPERATION PROCEDURE	PHOTOS/FIGURES
<p>11. REMOVING THE R32 SENSOR</p> <ul style="list-style-type: none">(1) Remove the panel and corner box. (Refer to procedure 1)(2) Remove the electrical box covers. (Refer to procedure 2)(3) Disconnect the R32 sensor connector (CNSA) on the indoor controller board.(4) Remove the screw fixing the R32 sensor (See Photo 15).(5) Remove the R32 sensor.	<p>Photo 15 (see the bottom)</p>  <p>Screw of the R32 sensor</p> <p>R32 sensor</p> <p>Cable strap</p> <p>Screw of electrical box</p>

9-1. REMOTE CONTROLLER FUNCTIONS

<PAR-41MAAB>

Controller interface

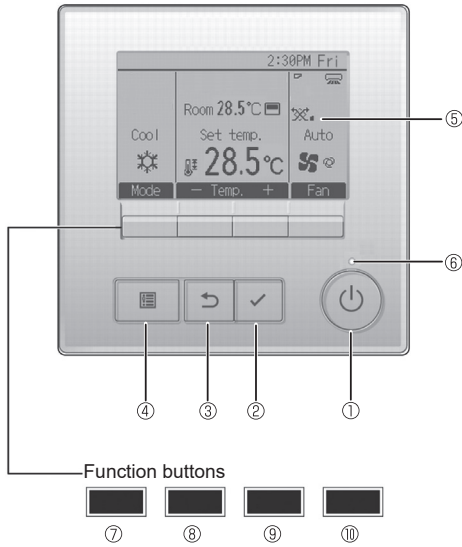

① [ON/OFF] button

Press to turn ON/OFF the indoor unit.

② [SELECT] button

Press to save the setting.

③ [RETURN] button

Press to return to the previous screen.

④ [MENU] button

Press to bring up the Main menu.

⑤ Backlit LCD

Operation settings will appear.

When the backlight is off, pressing any button turns the backlight on and it will stay lit for a certain period of time depending on the screen.

When the backlight is off, pressing any button turns the backlight on and does not perform its function. (except for the [ON/OFF] button)

The functions of the function buttons change depending on the screen.

Refer to the button function guide that appears at the bottom of the LCD for the functions they serve on a given screen.

When the system is centrally controlled, the button function guide that corresponds to the locked button will not appear.

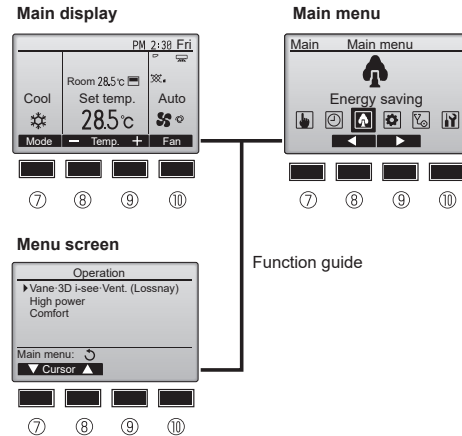

⑥ ON/OFF lamp

This lamp lights up in green while the unit is in operation. It blinks while the remote controller is starting up or when there is an error.

⑦ Function button [F1]

Main display: Press to change the operation mode.

Menu screen: The button function varies with the screen.

⑧ Function button [F2]

Main display: Press to decrease temperature.

Main menu: Press to move the cursor left.

Menu screen: The button function varies with the screen.

⑨ Function button [F3]

Main display: Press to increase temperature.

Main menu: Press to move the cursor right.

Menu screen: The button function varies with the screen.

⑩ Function button [F4]

Main display: Press to change the fan speed.

Menu screen: The button function varies with the screen.

Display

The main display can be displayed in two different modes: "Full" and "Basic". The initial setting is "Full". To switch to the "Basic" mode, change the setting on the Main display setting. (Refer to operation manual included with remote controller.)

<Full mode>

* All icons are displayed for explanation.

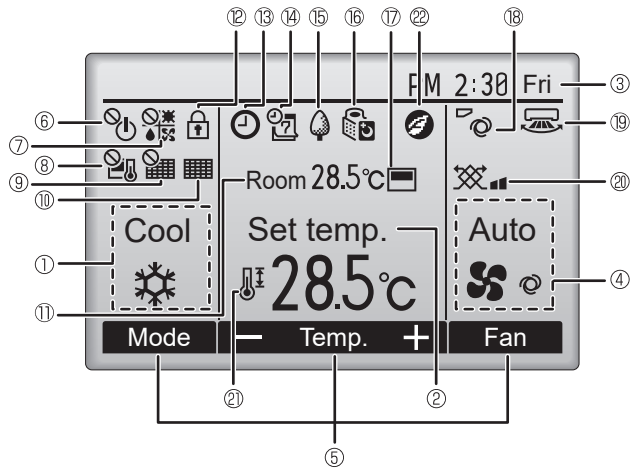

<Basic mode>

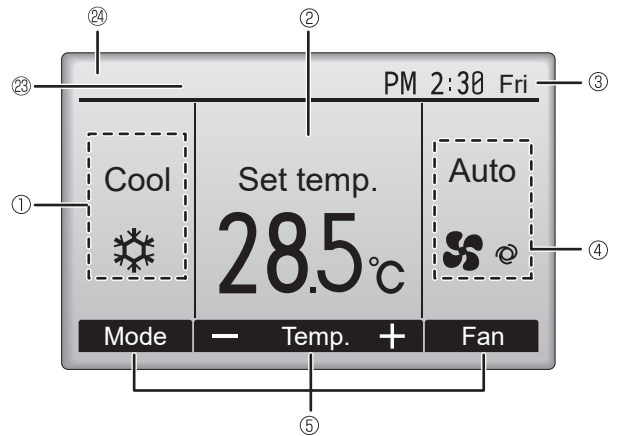

① Operation mode

② Preset temperature

③ Clock

④ Fan speed

⑤ Button function guide

Functions of the corresponding buttons appear here.



Appears when the ON/OFF operation is centrally controlled.



Appears when the operation mode is centrally controlled.



Appears when the preset temperature is centrally controlled.



Appears when the filter reset function is centrally controlled.



Indicates when filter needs maintenance.

⑪ Room temperature



Appears when the buttons are locked.



Appears when the On/Off timer, Night setback, or Auto-off timer function is enabled.



appears when the timer is disabled by the centralized control system.



Appears when the Weekly timer is enabled.



Appears while the units are operated in the energy saving mode. (Will not appear on some models of indoor units)



Appears while the outdoor units are operated in the silent mode.



Appears when the built-in thermistor on the remote controller is activated to monitor the room temperature (⑪).



appears when the thermistor on the indoor unit is activated to monitor the room temperature.



Indicates the vane setting.



Indicates the louver setting.



Indicates the ventilation setting.



Appears when the preset temperature range is restricted.



Appears when an energy saving operation is performed using a "3D i-see Sensor" function.

⑳ Centrally controlled

Appears for a certain period of time when a centrally-controlled item is operated.

㉔ Preliminary error display

A check code appears during the preliminary error.

Most settings (except ON/OFF, mode, fan speed, temperature) can be made from the Main menu.

*1 These functions are not applied to the floor standing models.

Menu structure

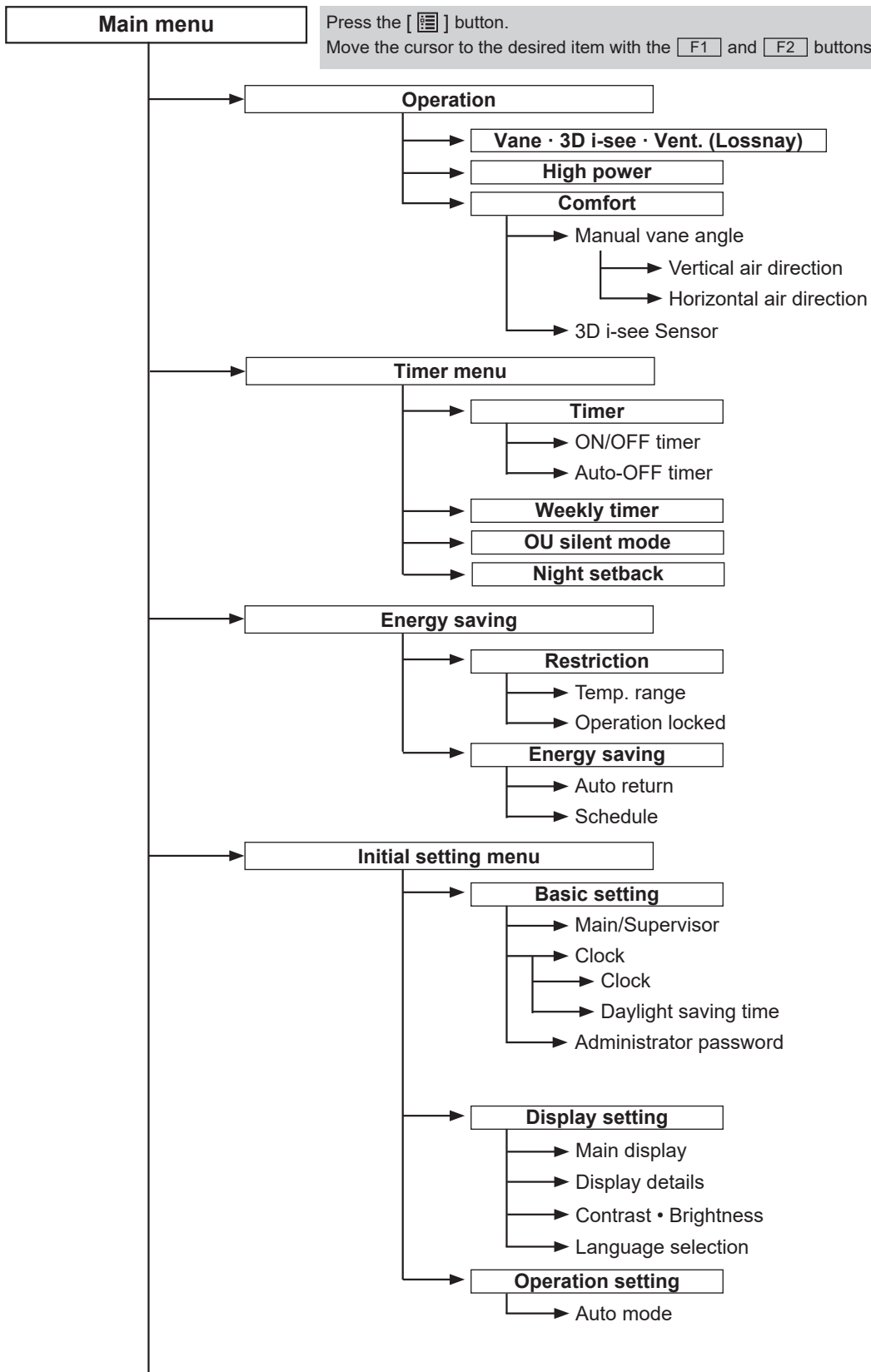

Continue to the next page.

Not all functions are available on all models of indoor units.

Continue from the previous page.

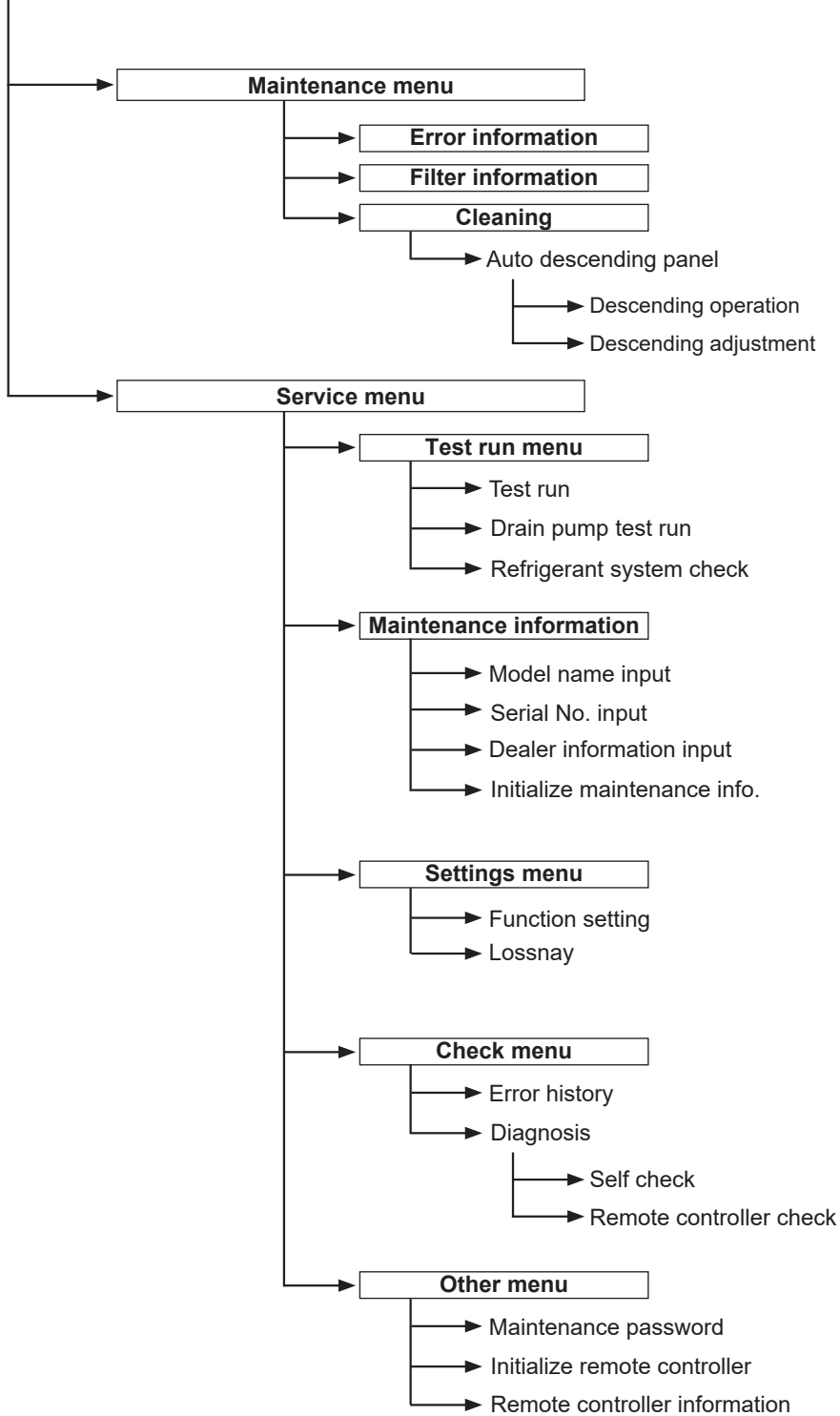

Not all functions are available on all models of indoor units.

Main menu list

Main menu	Setting and display items		Setting details
Operation	Vane · 3D i-see · Vent. (Vane · Vent. (Lossnay))		Vane: Use to set the vertical air direction. Louver: Use to set the horizontal air direction. 3D i-see Sensor: This setting is available only for the air conditioners that support easy setting function of motion sensing air direction. Vent: Use to set the amount of ventilation.
	High power *3		Use to reach the comfortable room temperature quickly. • Units can be operated in the High-power mode for up to 30 minutes.
	Comfort	Manual vane angle	Vertical air direction • Sets the vertical airflow direction (vane) of each unit. Horizontal air direction • Sets the horizontal airflow direction (vane) of each unit.
		3D i-see Sensor	Use to set the following functions for 3D i-see Sensor. • Air distribution • Energy saving option • Seasonal airflow
Timer	Timer	ON/OFF timer *1	Use to set the operation ON/OFF times. • Time can be set in 5-minute increments.
		Auto-OFF timer	Use to set the Auto-OFF time. • Time can be set to a value from 30 to 240 in 10-minute increments.
	Weekly timer *1, *2		Use to set the weekly operation ON/OFF times. • Up to 8 operation patterns can be set for each day. (Not valid when the ON/OFF timer is enabled.)
	OU silent mode *1, *3		Use to set the time periods in which priority is given to quiet operation of outdoor units over temperature control. Set the Start/Stop times for each day of the week. • Select the desired silent level from "Normal," "Middle," and "Quiet."
	Night setback *1		Use to make Night setback settings. • Select "Yes" to enable the setting, and "No" to disable the setting. The temperature range and the start/stop times can be set.
Energy saving	Restriction	Temp. range *2	Use to restrict the preset temperature range. • Different temperature ranges can be set for different operation modes.
		Operation lock	Use to lock selected functions. • The locked functions cannot be operated.
	Energy saving	Auto return *2	Use to get the units to operate at the preset temperature after performing energy saving operation for a specified time period. • Time can be set to a value from 30 and 120 in 10-minute increments. (This function will not be valid when the preset temperature ranges are restricted.)
		Schedule *1, *3	Set the start/stop times to operate the units in the energy saving mode for each day of the week, and set the energy saving rate. • Up to 4 energy saving operation patterns can be set for each day. • Time can be set in 5-minute increments. • Energy saving rate can be set to a value from 0% or 50 to 90% in 10% increments.
	Energy data (for unit time, month, and day)		Displays the amount of power consumption during operation. • Unit time data: Data for the last one-month period can be displayed in 30-minute units. • Monthly/daily data: Data for the last 14-month period are displayed in day-and-month-units. * Data can be deleted. * Data are obtained based on the power consumption estimated from the operating state.

*1 Clock setting is required.

*2 1°C increments

*3 This function is available only when certain outdoor units are connected.



Main menu	Setting and display items		Setting details
Initial setting	Basic setting	Main/Supervisor	For a system that requires supervisor remote controller, set the remote controller to "Supervisor" from this setting.
		Clock	Use to set the current time.
		Daylight saving time	Set the daylight saving time.
		Administrator password	The administrator password is required to make the settings for the following items. • Timer setting • Energy saving setting • Weekly timer setting • Restriction setting • Outdoor unit silent mode setting • Night set back
	Display setting	Main display	Use to switch between "Full" and "Basic" modes for the Main display, and use to change the background colors of the display to black.
		Display details	Make the settings for the remote controller related items as necessary. Clock: The initial settings are "Yes" and "24h" format. Temperature: Set either Celsius (°C) or Fahrenheit (°F). Room temp.: Set Show or Hide. Auto mode: Set Auto mode display or Only Auto display.
		Contrast • Brightness	Use to adjust screen contrast and brightness.
		Language selection	Use to select the desired language.
	Operation setting	Auto mode	Whether or not to use Auto mode can be selected by using the button. This setting is valid only when indoor units with Auto mode function are connected.
Maintenance	Error information		Use to check error information when an error occurs. • Check code, error source, refrigerant address, model name, manufacturing number, contact information (dealer's phone number) can be displayed. (The model name, manufacturing number, and contact information need to be registered in advance to be displayed.)
	Filter information		Use to check the filter status. • The filter sign can be reset.
	Cleaning	Auto descending panel	Use to lift and lower the auto descending panel (Optional parts).
Service	Test run		Select "Test run" from the Service menu to bring up the Test run menu. • Test run • Drain pump test run • Refrigerant system check
	Input maintenance info.		Select "Input maintenance Info." from the Service menu to bring up the Maintenance information screen. The following settings can be made from the Maintenance Information screen. • Model name input • Serial No. input • Dealer information input • Initialize maintenance info.
	Settings	Function setting	Make the settings for the indoor unit functions via the remote controller as necessary.
		LOSSNAY setting	This setting is required only when the operation of CITY MULTI units is interlocked with LOSSNAY units.
	Check	Error history	Display the error history and execute "delete error history".
		Diagnosis	Self check: Error history of each unit can be checked via the remote controller. Remote controller check: When the remote controller does not work properly, use the remote controller checking function to troubleshoot the problem.
	Others	Maintenance password	Use to change the maintenance password.
		Initialize remote controller	Use to initialize the remote controller to the factory shipment status.
		Remote controller information	Use to display the remote controller model name, software version, and serial number.

<PAR-SL97A-E>

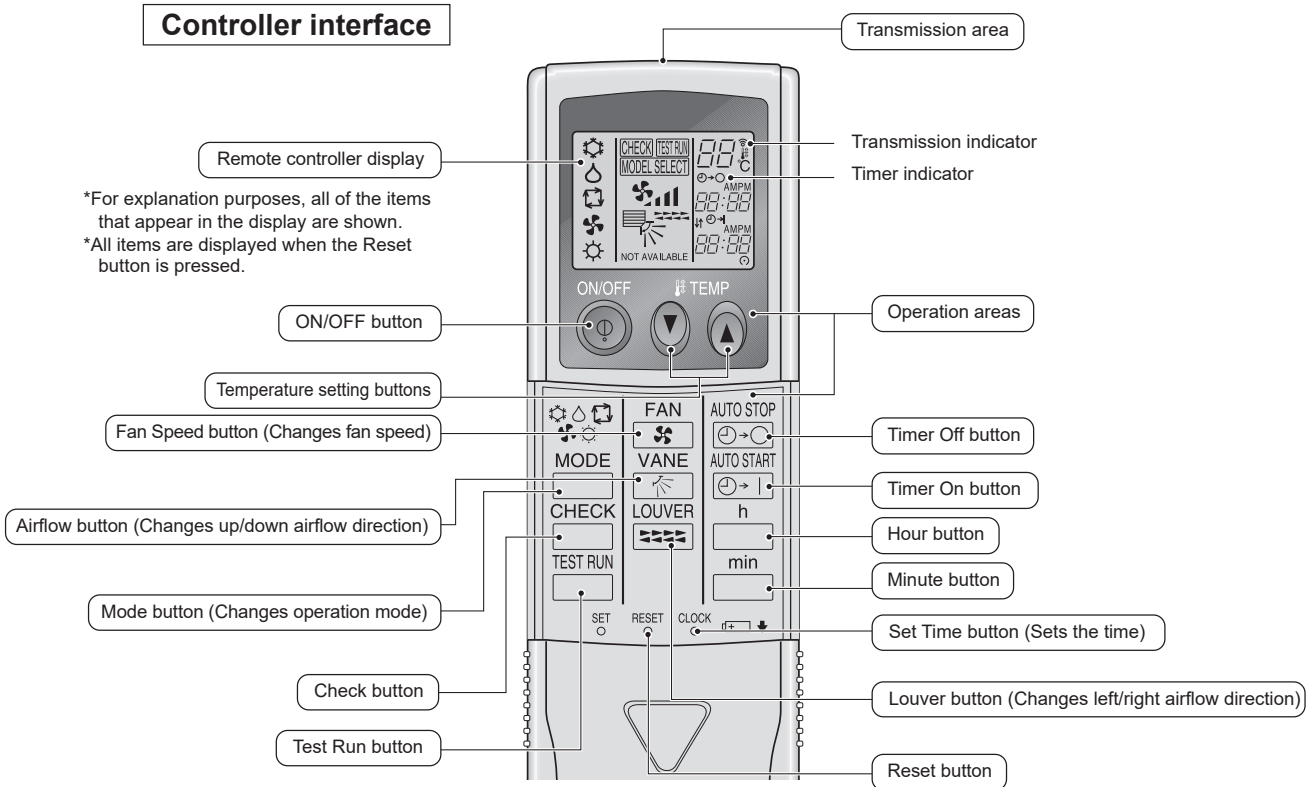

- When using the wireless remote controller, point it towards the receiver on the indoor unit.
- If the remote controller is operated within approximately three minutes after power is supplied to the indoor unit, the indoor unit may beep three times as the unit is performing the initial automatic check.
- The indoor unit beeps to confirm that the signal transmitted from the remote controller has been received. Signals can be received up to approximately 7 meters in a direct line from the indoor unit in an area 45 degrees to the left and right of the unit. However, illumination such as fluorescent lights and strong light can affect the ability of the indoor unit to receive signals.
- If the operation lamp near the receiver on the indoor unit is blinking, the unit needs to be inspected. Consult your dealer for service.
- Handle the remote controller carefully! Do not drop the remote controller or subject it to strong shocks. In addition, do not get the remote controller wet or leave it in a location with high humidity.
- To avoid misplacing the remote controller, install the holder included with the remote controller on a wall and be sure to always place the remote controller in the holder after use.

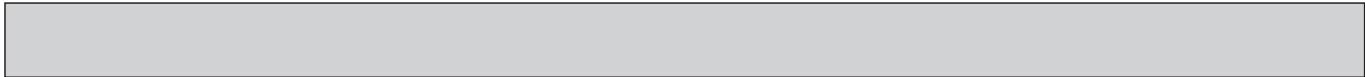

<PAR-SL101A-E>

Controller interface

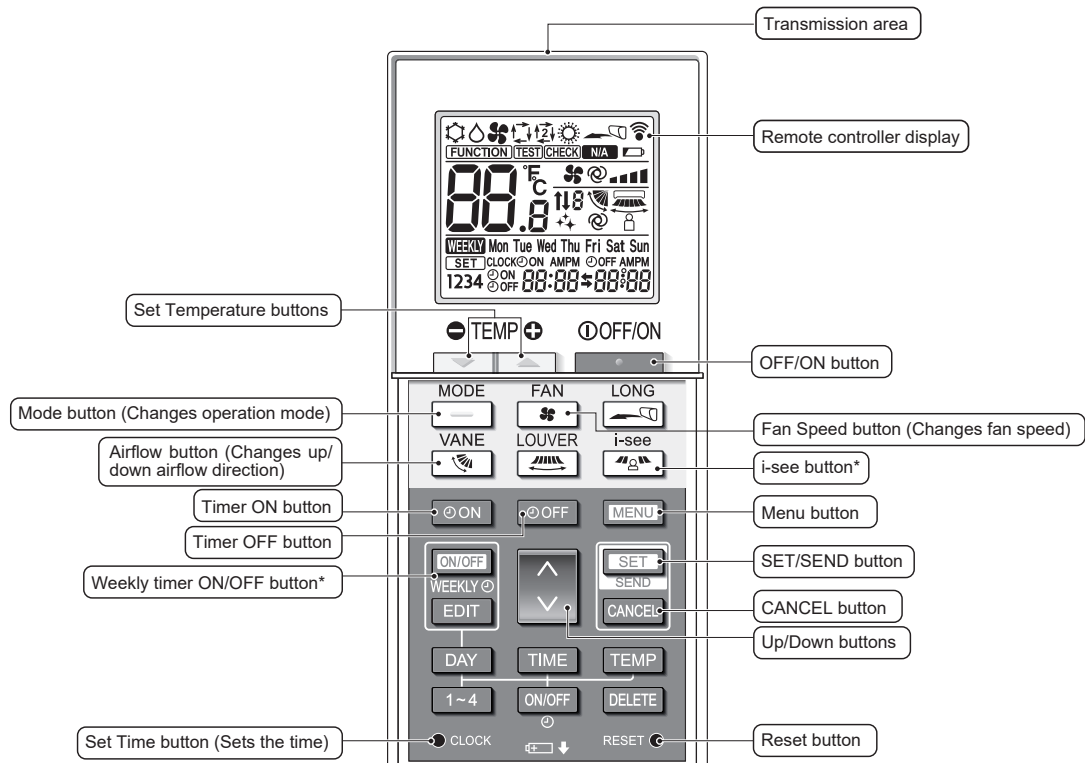

Note:
 * This button is enabled or disabled depending on the model of the indoor unit.

Display

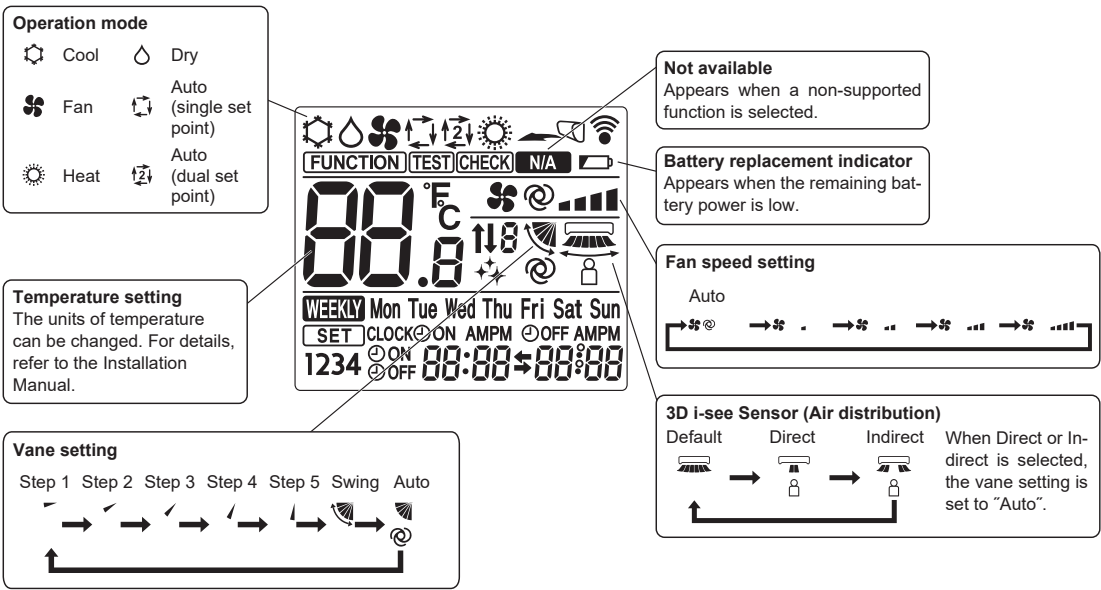

9-2. ERROR INFORMATION

**When an error occurs, the following screen will appear.
Check the error status, stop the operation, and consult your dealer.**

1. Check code, error unit, refrigerant address, date and time of occurrence, model name, and serial number will appear.
The model name and serial number will appear only if the information have been registered.

Press the **[F1]** or **[F2]** button to go to the next page.

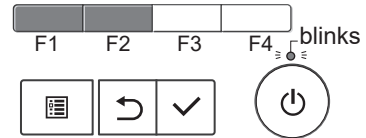
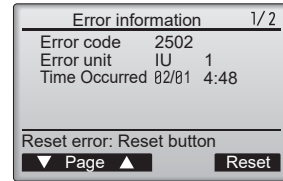

Contact information (dealer's phone number) will appear if the information has been registered.

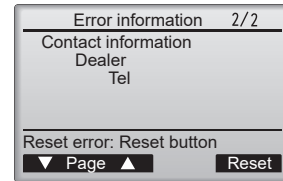

2. Press the **[F4]** button or the  button to reset the error that is occurring.

Errors cannot be reset while the ON/OFF operation is prohibited.

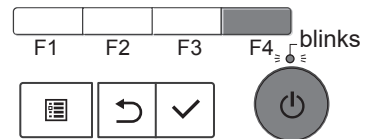
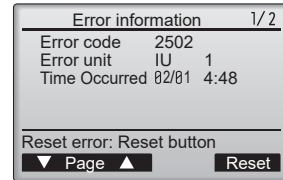

Select "OK" with the **[F4]** button.

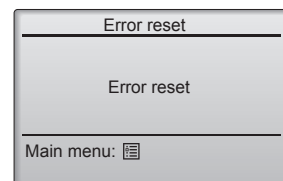
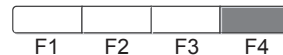
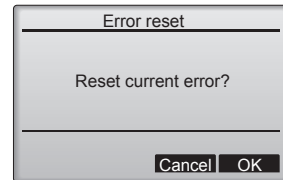

Navigating through the screens

- To go back to the Service menu  button

• Checking the error information

While no errors are occurring, page 2/2 of the error information can be viewed by selecting "Error information" from the Maintenance menu. Errors cannot be reset from this screen.

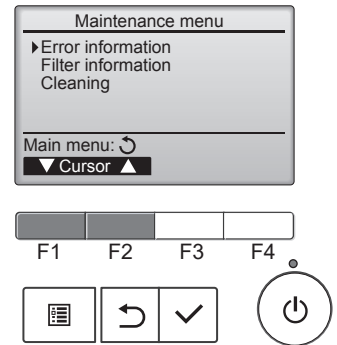

9-3. SERVICE MENU

Maintenance password is required

1. Select "Service" from the Main menu, and press the [✓] button.

*At the main display, the menu button and select "Service" to make the maintenance setting.

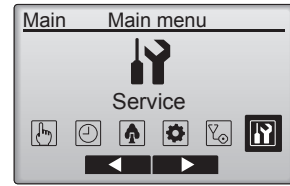

2. When the Service menu is selected, a window will appear asking for the password.

To enter the current maintenance password (4 numerical digits), move the cursor to the digit you want to change with the [F1] or [F2] button.



Set each number (0 through 9) with the [F3] or [F4] button.



Then, press the [✓] button.

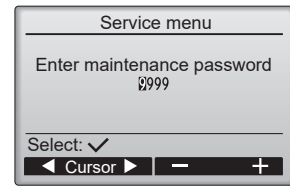

Note: The initial maintenance password is "9999". Change the default password as necessary to prevent unauthorized access. Have the password available for those who need it.

If you forget your maintenance password, you can initialize the password to the default password "9999" by pressing and holding the [F1] button for 10 seconds on the maintenance password setting screen.

3. If the password matches, the Service menu will appear.

Note: Air conditioning units may need to be stopped to make only at "Settings". There may be some settings that cannot be made when the system is centrally controlled.



A screen will appear that indicates the setting has been saved.

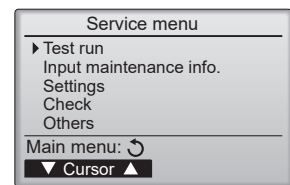

Navigating through the screens

- To go back to the Service menu[List] button
- To return to the previous screen.....[Return] button

9-4. TEST RUN

9-4-1. PAR-41MAAB

1. Select "Service" from the Main menu, and press the [✓] button.



Select "Test run" with the [F1] or [F2] button, and press the [✓] button.

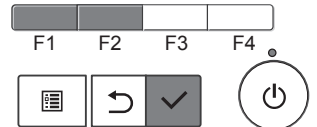
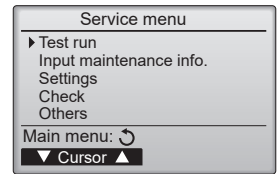

2. Select "Test run" with the [F1] or [F2] button, and press the [✓] button.

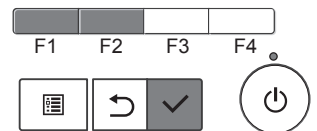
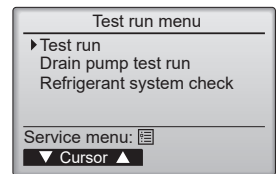

Test run operation

Press the [F1] button to go through the operation modes in the order of "Cool and Heat".

Cool mode: Check the cold air blows out.
Heat mode: Check the heat blows out.

Check the operation of the outdoor unit's fan.



Press the [✓] button and open the Vane setting screen.

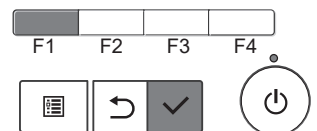
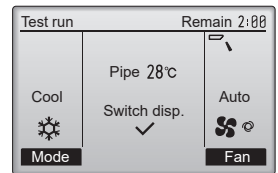

Auto vane check

Check the auto vane with the [F1] [F2] [F3] buttons.



Press the [Return] button to return to "Test run operation".



Press the [Power] button.





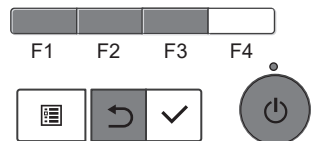
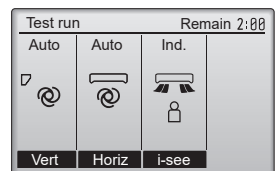





When the test run is completed, the "Test run menu" screen will appear.
The test run will automatically stop after 2 hours.

*The function is available only for the model with vanes.



9-4-2. PAR-SL97A-E

Measure an impedance between the power supply terminal block on the outdoor unit and ground with a 500 V Megger and check that it is equal to or greater than 1.0 MΩ.







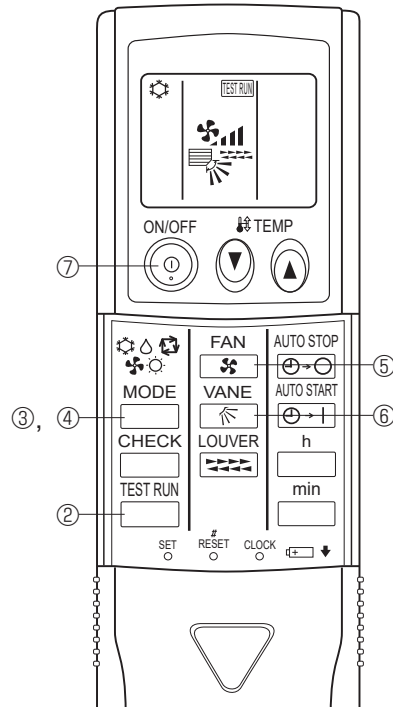







1. Turn on the main power to the unit.
2. Press the  button twice continuously.
(Start this operation from the status of remote controller display turned off.)
A  and current operation mode are displayed.
3. Press the  () button to activate  mode, then check whether cool air blows out from the unit.
4. Press the  () button to activate  mode, then check whether warm air blows out from the unit.
5. Press the  button and check whether strong air blows out from the unit.
6. Press the  button and check whether the auto vane operates properly.
7. Press the ON/OFF button to stop the test run.

Note:

- Point the remote controller towards the indoor unit receiver while following steps 2 to 7.
- It is not possible to run in FAN, DRY or AUTO mode.



9-4-3. PAR-SL101A-E

1. Press the  button ① to stop the air conditioner.
 - If the weekly timer is enabled ( is on), press the  button ③ to disable it ( is off).
2. Press the  button ② for 5 seconds.
 -  comes on and the unit enters the service mode.
3. Press the  button ②.
 -  ④ comes on and the unit enters the test run mode.
4. Press the following buttons to start the test run.
 - : Switch the operation mode between cooling and heating and start the test run.
 - : Switch the fan speed and start the test run.
 - : Switch the airflow direction and start the test run.
 - : Switch the louver and start the test run.
 - : Start the test run.
5. Stop the test run.
 - Press the  button ① to stop the test run.
 - After 2 hours, the stop signal is transmitted.

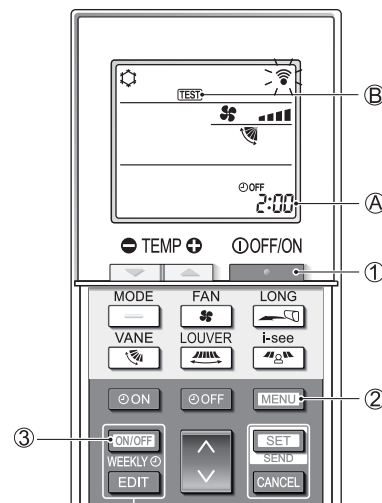

9-5. FUNCTION SETTING

9-5-1. PAR-41MAAB

1. Select "Service" from the Main menu, and press the [✓] button.



Select "Setting" from the Service menu, and press the [✓] button.



Select "Function setting", and press the [✓] button.

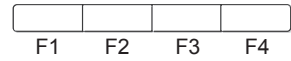
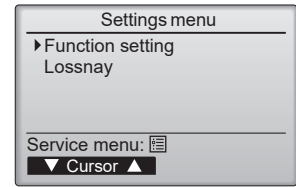

2. The Function setting screen will appear.

Press the [F1] or [F2] button to move the cursor to one of the following: M-NET address, function setting number, or setting value. Then, press the [F3] or [F4] button to change the settings to the desired settings.



Once the settings have been completed, press the [✓] button.

A screen will appear indicating that the settings information is being sent.

To check the current settings of a given unit, enter the setting for its M-NET address and function setting number, select Conf for the Function, and press the [✓] button.

A screen will appear indicating that the settings are being searched for.

When the search is done, the current settings will appear.



When the settings information has been sent, a screen will appear indicating its completion.

To make additional settings, press the [↻] button to return to the screen shown in the above step. Set the function numbers for other indoor units by following the same steps.

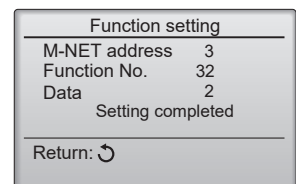
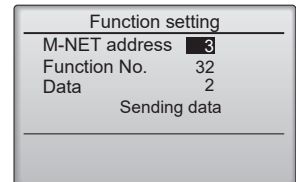
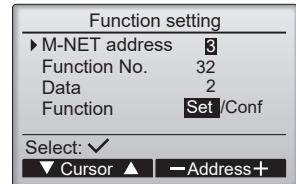

Note:

- Refer to the indoor unit Installation Manual for information about the factory settings of indoor units, function setting numbers, and setting values.
- Be sure to write down the settings for all functions if any of the initial settings has been changed after the completion of installation work.

9-6. ERROR HISTORY

1. Select "Service" from the Main menu, and press the [✓] button.



Select "Check" with the [F1] or [F2] button, and press the [✓] button.

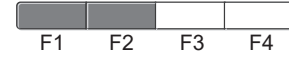
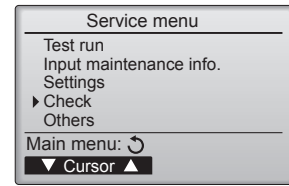

2. Select "Error history" with the [F1] or [F2] button, and press the [✓] button.

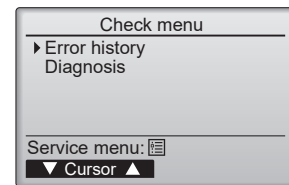

3. 16 error history records will appear.

4 records are shown per page, and the top record on the first page indicates the latest error record.

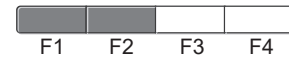
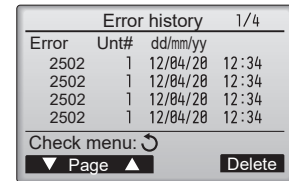

4. Deleting the error history

To delete the error history, press the [F4] button (Delete) on the screen that shows error history. A confirmation screen will appear asking if you want to delete the error history.



Press the [F4] button (OK) to delete the history.



"Error history deleted" will appear on the screen.

Press the [↻] button to go back to the Check menu screen.

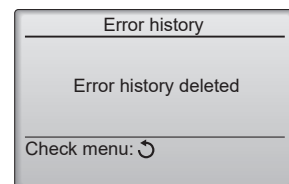
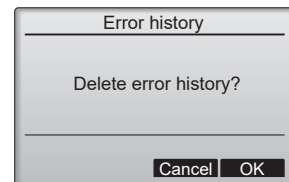

9-7. SELF-DIAGNOSIS

9-7-1. PAR-41MAAB

1. Select "Service" from the Main menu, and press the [✓] button.

Select "Check" from the Service menu, and press the [✓] button.

Select "Diagnosis" from the Check menu, and press the [✓] button.

Select "Self check" with the [F1] or [F2] button, and press the [✓] button.

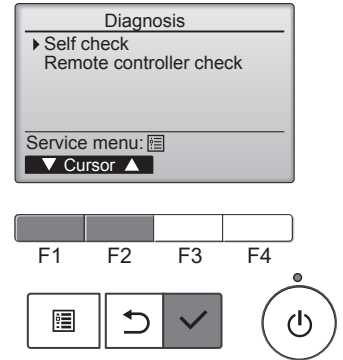

2. Select "Self check" from the Diagnosis menu, and press the [✓] button to view the Self check screen.

With the [F1] or [F2] button, enter the M-NET address, and press the [✓] button.

Check code, unit number, attribute, and indoor unit demand signal ON/OFF status at the contact will appear. "-" will appear if no error history is available.

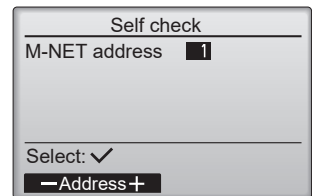

When there is no error history

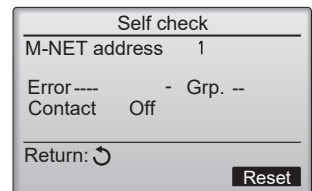
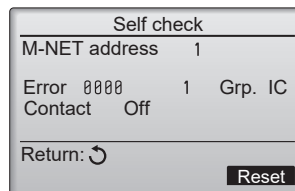

3. Resetting the error history

Press the [F4] button (Reset) on the screen that shows the error history. A confirmation screen will appear asking if you want to delete the error history.

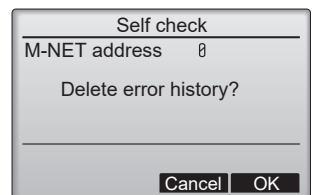

Press the [F4] button (OK) to delete the error history. If deletion fails, "Request rejected" will appear, and "Unit not exist" will appear if indoor units that correspond to the entered address are not found.

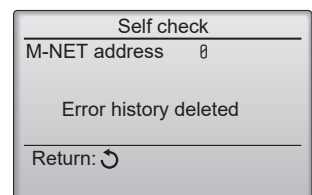

9-7-2. PAR-SL97A-E

<Malfunction-diagnosis method at maintenance service>

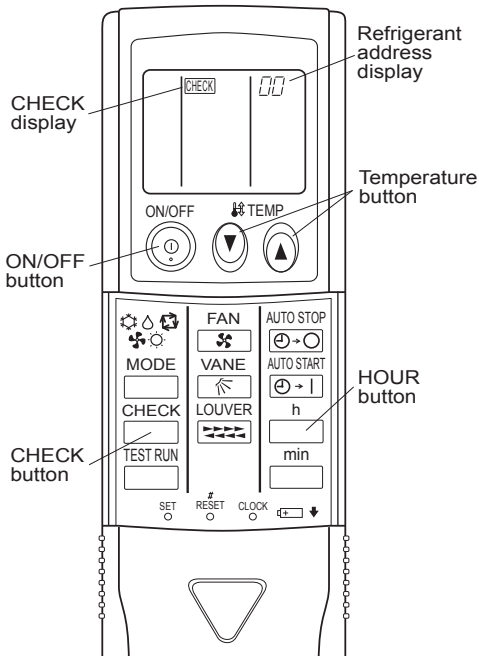

[Procedure]

1. Press the CHECK button twice.
 - "CHECK" lights, and refrigerant address "00" blinks.
 - Check that the remote controller's display has stopped before continuing.
2. Press the TEMP (⬇️) (⬆️) buttons to select the refrigerant address of the indoor unit for self-diagnosis.
 - Set the address of the indoor unit that is to be self-diagnosed.
3. Point the remote controller at the sensor on the indoor unit and press the HOUR button.
 - If an air conditioner error occurs, the indoor unit's sensor emits an intermittent buzzer sound, the operation light blinks, and the check code is output.
4. Point the remote controller at the sensor on the indoor unit and press the ON/OFF button.
 - The check mode is cancelled.

9-7-3. PAR-SL101A-E

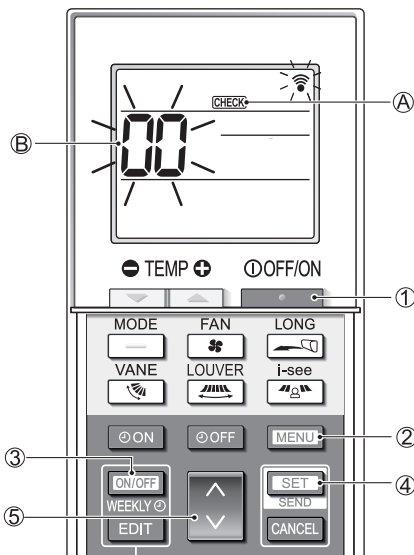

[Procedure]

1. Press the (⏻) button ① to stop the air conditioner.
 - If the weekly timer is enabled (WEEKLY is on), press the (ON/OFF WEEKLY) button ③ to disable it (WEEKLY is off).
2. Press the (MENU) button ② for 5 seconds.
 - (CHECK) (A) comes on and the unit enters the self-check mode.
3. Press the (⬇️) button ⑤ to select the refrigerant address (M-NET address) (B) of the indoor unit for which you want to perform the self-check.
4. Press the (SET) button ④.
 - If an error is detected, the check code is indicated by the number of beeps from the indoor unit and the number of blinks of the OPERATION INDICATOR lamp.
5. Press the (⏻) button ①.
 - (CHECK) (A) and the refrigerant address (M-NET address) (B) go off and the self-check is completed.

9-8. REMOTE CONTROLLER CHECK

If operations cannot be completed with the remote controller, diagnose the remote controller with this function.

1. Select "Service" from the Main menu, and press the [✓] button.



Select "Check" from the Service menu, and press the [✓] button.



Select "Diagnosis" from the Check menu, and press the [✓] button.



Select "Remote controller check" with the [F1] or [F2] button, and press the [✓] button.

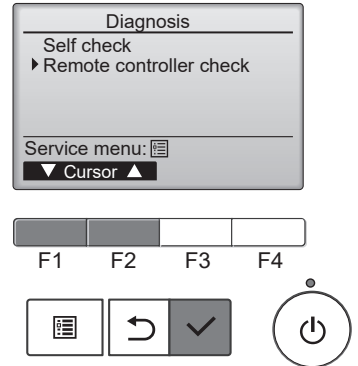

2. Select "Remote controller check" from the Diagnosis menu, and press the [✓] button to start the remote controller check and see the check results.



To cancel the remote controller check and exit the "Remote controller check" menu screen, press the [F1] or the [F2] button.



The remote controller will not reboot itself.

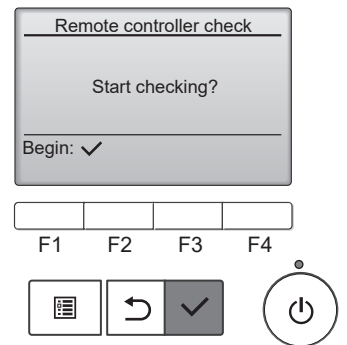

3.
 - OK: No problems are found with the remote controller. Check other parts for problems.
 - E3, 6832: There is noise on the transmission line, or the indoor unit or another remote controller is faulty. Check the transmission line and the other remote controllers.
 - NG (ALL0, ALL1): Send-receive circuit fault. The remote controller needs replacing.
 - ERC: The number of data errors is the discrepancy between the number of bits in the data transmitted from the remote controller and that of the data that was actually transmitted over the transmission line. If data errors are found, check the transmission line for external noise interference.



If the [✓] button is pressed after the remote controller check results are displayed, remote controller check will end, and the remote controller will automatically reboot itself.

Remote controller check results screen

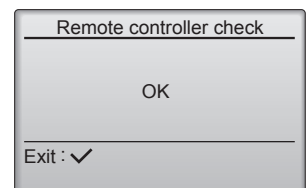

Check the remote controller display and see if anything is displayed (including lines). Nothing will appear on the remote controller display if the correct voltage (8.5–12 VDC) is not supplied to the remote controller. If this is the case, check the remote controller wiring and indoor units.

MITSUBISHI ELECTRIC CORPORATION

HEAD OFFICE: TOKYO BUILDING, 2-7-3, MARUNOUCHI, CHIYODA-KU TOKYO 100-8310, JAPAN
