

SERVICE PARTS LIST FOR MITSUBISHI ELECTRIC PACKAGED AIR-CONDITIONERS

Series : PEFY-W·VMA(2)-A.UK
PEFY-W·VMAL-A.UK

REVISED

Oct. 2019

BWE01842A

INDEX

PEFY-W20VMA(2)(L)-A.UK

PEFY-W25VMA(2)(L)-A.UK

PEFY-W32VMA(2)(L)-A.UK

PEFY-W40VMA(2)(L)-A.UK

PEFY-W50VMA(2)(L)-A.UK

PEFY-W63VMA(2)(L)-A.UK

PEFY-W71VMA(2)(L)-A.UK

PEFY-W80VMA(2)(L)-A.UK

PEFY-W100VMA(2)(L)-A.UK

PEFY-W125VMA(2)(L)-A.UK

Part information update day : 2019/10/01

Please change the old catalog (issued Jan. 2019, No.BWE018420) to this new catalog.
Content of revision : Some of parts are changed.



PEFY-W20,W25,W32,W40VMA(2)-A.UK
 PEFY-W50,W63,W71,W80VMA(2)-A.UK
 PEFY-W100,W125VMA(2)-A.UK

EXTERNAL PARTS (1)

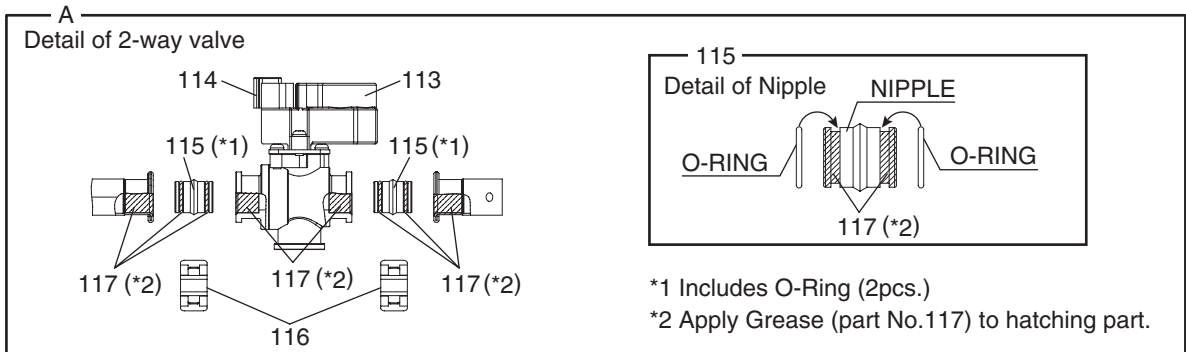
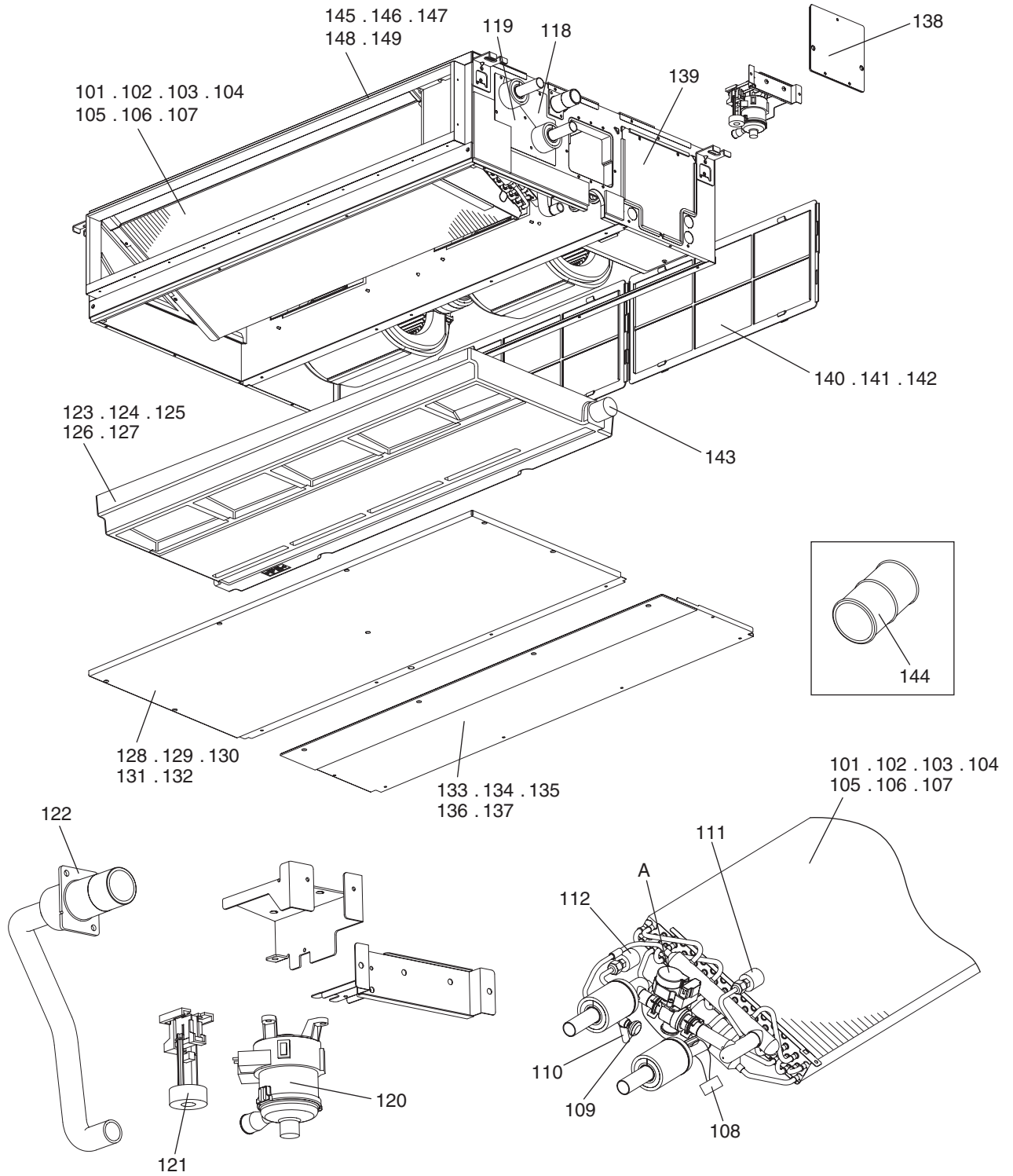

PEFY-W20,W25,W32,W40VMA(2)-A.UK
 PEFY-W50,W63,W71,W80VMA(2)-A.UK
 PEFY-W100,W125VMA(2)-A.UK

EXTERNAL PARTS (1)

No.	Part No.	Part Name	Spec.	PEFY-W20VMA-A.UK	PEFY-W25VMA-A.UK	PEFY-W32VMA-A.UK	PEFY-W40VMA-A.UK	PEFY-W50VMA-A.UK	PEFY-W63VMA-A.UK	Dwg. No.	Notes for the models	Revision info.
101	S70 W01 480	HEAT EXCHANGER		1	1					KB00Y431B03		Chg.
102	S70 W02 480	HEAT EXCHANGER				1				KB00Y431B04		Chg.
103	S70 W03 480	HEAT EXCHANGER					1			KB00Y430B02		Chg.
104	S70 W04 480	HEAT EXCHANGER						1	1	KB00Y429B02		Chg.
105	S70 W05 480	HEAT EXCHANGER								KB00Y428B02		Chg.
106	S70 W06 480	HEAT EXCHANGER								KB00Y427B03		Chg.
107	S70 W07 480	HEAT EXCHANGER								KB00Y427B04		Chg.
108	S70 100 202	THERMISTOR		1	1	1	1	1	1	KB71B945M01		
109	S70 W40 151	AIR PURGE VALVE		1	1	1	1	1	1	BT50C889H01		
110	S70 W10 111	TUBE	PVC	1	1	1	1	1	1	BG27L986H63		
111	S70 W10 208	PRES.SENSOR	IN	1	1	1	1	1	1	KR51C556H01		
112	S70 W20 208	PRES.SENSOR	OUT	1	1	1	1	1	1	KR51C558H01		
113	S70 W10 406	2-WAY VALVE		1	1	1	1	1	1	KR50B237H01		
114	S70 W20 407	2-WAY VALVE CAP		1	1	1	1	1	1	KR32C548H01		
115	S70 W30 409	NIPPLE SET		2	2	2	2	2	2	KJ00M546G01	*1 Includes O-RING (2pcs.)	Chg.
116	S70 W30 465	FASTENER	12.7	2	2	2	2	2	2	KR20C549H01		
117	S70 C01 800	GREASE	100g	1	1	1	1	1	1	RG88D941K01	*2	
118	S70 W10 065	COVER PIPE ASSY 1		1	1	1	1	1	1	KJ00K354G01		
119	S70 W20 065	COVER PIPE ASSY 2		1	1	1	1	1	1	KJ00K343G01		
120	S70 0B2 355	PUMP	PMD	1	1	1	1	1	1	BH56B946H05		
121	S70 0B2 266	FLOAT SWITCH		1	1	1	1	1	1	BH68T992K01		
122	S70 E50 527	SOCKET ASSY		1	1	1	1	1	1	KB00R308G05		
123	S70 E10 529	DRAIN PAN ASSY	W20	1	1	1				KB00R237G01		
124	S70 E20 529	DRAIN PAN ASSY	W40				1			KB00R237G02		
125	S70 E30 529	DRAIN PAN ASSY	W50					1	1	KB00R237G03		
126	S70 E40 529	DRAIN PAN ASSY	W100							KB00R237G04		
127	S70 E50 529	DRAIN PAN ASSY	W50(2)							KB00R237G05		
128	S70 W01 669	PANEL ASSY UD1	W20	1	1	1				KL00R438G01		
129	S70 W02 669	PANEL ASSY UD1	W40				1			KL00R438G02		
130	S70 W03 669	PANEL ASSY UD1	W50					1	1	KL00R438G03		
131	S70 W04 669	PANEL ASSY UD1	W100							KL00R438G04		
132	S70 W05 669	PANEL ASSY UD1	W50(2)							KL00R438G05		
133	S70 E02 669	PANEL ASSY UD2	W20	1	1	1				KB00R306G16		
134	S70 E04 669	PANEL ASSY UD2	W40				1			KB00R306G17		
135	S70 E06 669	PANEL ASSY UD2	W50					1	1	KB00R306G18		
136	S70 E08 669	PANEL ASSY UD2	W100							KB00R306G21		
137	S70 E10 669	PANEL ASSY UD2	W50(2)							KB00R306G22		
138	S70 E12 067	COVER ASSY		1	1	1	1	1	1	KB00M197G06		
139	S70 E13 068	COVER BOX ASSY		1	1	1	1	1	1	KB00T337G02		
140	S70 E55 500	FILTER	550					2	2	KD35J684G01		
141	S70 E70 500	FILTER	700	1	1	1				KD35J685G01		
142	S70 E90 500	FILTER	900				1			KD35J686G01		
143	S70 E16 524	PLUG	RUBBER	1	1	1	1	1	1	KB26H049H01		
144	S70 29H 523	SOCKET		1	1	1	1	1	1	BB25D449K01		
145	S70 E10 642	PANEL TOP ASSY	W20	1	1	1				KB00R292G06		

PEFY-W20,W25,W32,W40VMA(2)-A.UK
 PEFY-W50,W63,W71,W80VMA(2)-A.UK
 PEFY-W100,W125VMA(2)-A.UK

EXTERNAL PARTS (1)

No.	Part No.	Part Name	Spec.	PEFY-W20VMA-A.UK	PEFY-W25VMA-A.UK	PEFY-W32VMA-A.UK	PEFY-W40VMA-A.UK	PEFY-W50VMA-A.UK	PEFY-W63VMA-A.UK	Dwg. No.	Notes for the models	Revision info.
146	S70 E60 642	PANEL TOP ASSY	W40				1			KB00R292G13		
147	S70 E30 642	PANEL TOP ASSY	W50					1	1	KB00R292G08		
148	S70 E40 642	PANEL TOP ASSY	W100							KB00R292G11		
149	S70 E50 642	PANEL TOP ASSY	W50(2)							KB00R292G12		

PEFY-W20,W25,W32,W40VMA(2)-A.UK
 PEFY-W50,W63,W71,W80VMA(2)-A.UK
 PEFY-W100,W125VMA(2)-A.UK

EXTERNAL PARTS (1)

No.	Part No.	Part Name	Spec.	PEFY-W71VMA-A.UK	PEFY-W80VMA-A.UK	PEFY-W100VMA-A.UK	PEFY-W125VMA-A.UK	PEFY-W20VMA2-A.UK	PEFY-W25VMA2-A.UK	Dwg. No.	Notes for the models	Revision info.
101	S70 W01 480	HEAT EXCHANGER								KB00Y431B03		Chg.
102	S70 W02 480	HEAT EXCHANGER								KB00Y431B04		Chg.
103	S70 W03 480	HEAT EXCHANGER								KB00Y430B02		Chg.
104	S70 W04 480	HEAT EXCHANGER		1	1			1	1	KB00Y429B02		Chg.
105	S70 W05 480	HEAT EXCHANGER				1				KB00Y428B02		Chg.
106	S70 W06 480	HEAT EXCHANGER					1			KB00Y427B03		Chg.
107	S70 W07 480	HEAT EXCHANGER								KB00Y427B04		Chg.
108	S70 100 202	THERMISTOR		1	1	1	1	1	1	KB71B945M01		
109	S70 W40 151	AIR PURGE VALVE		1	1	1	1	1	1	BT50C889H01		
110	S70 W10 111	TUBE	PVC	1	1	1	1	1	1	BG27L986H63		
111	S70 W10 208	PRES.SENSOR	IN	1	1	1	1	1	1	KR51C556H01		
112	S70 W20 208	PRES.SENSOR	OUT	1	1	1	1	1	1	KR51C558H01		
113	S70 W10 406	2-WAY VALVE		1	1	1	1	1	1	KR50B237H01		
114	S70 W20 407	2-WAY VALVE CAP		1	1	1	1	1	1	KR32C548H01		
115	S70 W30 409	NIPPLE SET		2	2	2	2	2	2	KJ00M546G01	*1 Includes O-RING (2pcs.)	Chg.
116	S70 W30 465	FASTENER	12.7	2	2	2	2	2	2	KR20C549H01		
117	S70 C01 800	GREASE	100g	1	1	1	1	1	1	RG88D941K01	*2	
118	S70 W10 065	COVER PIPE ASSY 1		1	1	1	1	1	1	KJ00K354G01		
119	S70 W20 065	COVER PIPE ASSY 2		1	1	1	1	1	1	KJ00K343G01		
120	S70 0B2 355	PUMP	PMD	1	1	1	1	1	1	BH56B946H05		
121	S70 0B2 266	FLOAT SWITCH		1	1	1	1	1	1	BH68T992K01		
122	S70 E50 527	SOCKET ASSY		1	1	1	1	1	1	KB00R308G05		
123	S70 E10 529	DRAIN PAN ASSY	W20							KB00R237G01		
124	S70 E20 529	DRAIN PAN ASSY	W40							KB00R237G02		
125	S70 E30 529	DRAIN PAN ASSY	W50	1	1			1	1	KB00R237G03		
126	S70 E40 529	DRAIN PAN ASSY	W100			1	1			KB00R237G04		
127	S70 E50 529	DRAIN PAN ASSY	W50(2)							KB00R237G05		
128	S70 W01 669	PANEL ASSY UD1	W20							KL00R438G01		
129	S70 W02 669	PANEL ASSY UD1	W40							KL00R438G02		
130	S70 W03 669	PANEL ASSY UD1	W50	1	1			1	1	KL00R438G03		
131	S70 W04 669	PANEL ASSY UD1	W100			1	1			KL00R438G04		
132	S70 W05 669	PANEL ASSY UD1	W50(2)							KL00R438G05		
133	S70 E02 669	PANEL ASSY UD2	W20							KB00R306G16		
134	S70 E04 669	PANEL ASSY UD2	W40							KB00R306G17		
135	S70 E06 669	PANEL ASSY UD2	W50	1	1			1	1	KB00R306G18		
136	S70 E08 669	PANEL ASSY UD2	W100			1	1			KB00R306G21		
137	S70 E10 669	PANEL ASSY UD2	W50(2)							KB00R306G22		
138	S70 E12 067	COVER ASSY		1	1	1	1	1	1	KB00M197G06		
139	S70 E13 068	COVER BOX ASSY		1	1	1	1	1	1	KB00T337G02		
140	S70 E55 500	FILTER	550	2	2			2	2	KD35J684G01		
141	S70 E70 500	FILTER	700			2	2			KD35J685G01		
142	S70 E90 500	FILTER	900							KD35J686G01		
143	S70 E16 524	PLUG	RUBBER	1	1	1	1	1	1	KB26H049H01		
144	S70 29H 523	SOCKET		1	1	1	1	1	1	BB25D449K01		
145	S70 E10 642	PANEL TOP ASSY	W20							KB00R292G06		

PEFY-W20,W25,W32,W40VMA(2)-A.UK
 PEFY-W50,W63,W71,W80VMA(2)-A.UK
 PEFY-W100,W125VMA(2)-A.UK

EXTERNAL PARTS (1)

No.	Part No.	Part Name	Spec.	PEFY-W20VMA2-A.UK	PEFY-W25VMA2-A.UK	PEFY-W32VMA2-A.UK	PEFY-W40VMA2-A.UK	PEFY-W50VMA2-A.UK	PEFY-W63VMA2-A.UK	PEFY-W71VMA2-A.UK	PEFY-W80VMA2-A.UK	Dwg. No.	Notes for the models	Revision info.
101	S70 W01 480	HEAT EXCHANGER										KB00Y431B03		Chg.
102	S70 W02 480	HEAT EXCHANGER										KB00Y431B04		Chg.
103	S70 W03 480	HEAT EXCHANGER										KB00Y430B02		Chg.
104	S70 W04 480	HEAT EXCHANGER		1	1							KB00Y429B02		Chg.
105	S70 W05 480	HEAT EXCHANGER										KB00Y428B02		Chg.
106	S70 W06 480	HEAT EXCHANGER										KB00Y427B03		Chg.
107	S70 W07 480	HEAT EXCHANGER				1	1	1	1	1		KB00Y427B04		Chg.
108	S70 100 202	THERMISTOR		1	1	1	1	1	1	1		KB71B945M01		
109	S70 W40 151	AIR PURGE VALVE		1	1	1	1	1	1	1		BT50C889H01		
110	S70 W10 111	TUBE	PVC	1	1	1	1	1	1	1		BG27L986H63		
111	S70 W10 208	PRES.SENSOR	IN	1	1	1	1	1	1	1		KR51C556H01		
112	S70 W20 208	PRES.SENSOR	OUT	1	1	1	1	1	1	1		KR51C558H01		
113	S70 W10 406	2-WAY VALVE		1	1	1	1	1	1	1		KR50B237H01		
114	S70 W20 407	2-WAY VALVE CAP		1	1	1	1	1	1	1		KR32C548H01		
115	S70 W30 409	NIPPLE SET		2	2	2	2	2	2	2		KJ00M546G01	*1 Includes O-RING (2pcs.)	Chg.
116	S70 W30 465	FASTENER	12.7	2	2	2	2	2	2	2		KR20C549H01		
117	S70 C01 800	GREASE	100g	1	1	1	1	1	1	1		RG88D941K01	*2	
118	S70 W10 065	COVER PIPE ASSY 1		1	1	1	1	1	1	1		KJ00K354G01		
119	S70 W20 065	COVER PIPE ASSY 2		1	1	1	1	1	1	1		KJ00K343G01		
120	S70 0B2 355	PUMP	PMD	1	1	1	1	1	1	1		BH56B946H05		
121	S70 0B2 266	FLOAT SWITCH		1	1	1	1	1	1	1		BH68T992K01		
122	S70 E50 527	SOCKET ASSY		1	1	1	1	1	1	1		KB00R308G05		
123	S70 E10 529	DRAIN PAN ASSY	W20									KB00R237G01		
124	S70 E20 529	DRAIN PAN ASSY	W40									KB00R237G02		
125	S70 E30 529	DRAIN PAN ASSY	W50	1	1							KB00R237G03		
126	S70 E40 529	DRAIN PAN ASSY	W100									KB00R237G04		
127	S70 E50 529	DRAIN PAN ASSY	W50(2)			1	1	1	1	1		KB00R237G05		
128	S70 W01 669	PANEL ASSY UD1	W20									KL00R438G01		
129	S70 W02 669	PANEL ASSY UD1	W40									KL00R438G02		
130	S70 W03 669	PANEL ASSY UD1	W50	1	1							KL00R438G03		
131	S70 W04 669	PANEL ASSY UD1	W100									KL00R438G04		
132	S70 W05 669	PANEL ASSY UD1	W50(2)			1	1	1	1	1		KL00R438G05		
133	S70 E02 669	PANEL ASSY UD2	W20									KB00R306G16		
134	S70 E04 669	PANEL ASSY UD2	W40									KB00R306G17		
135	S70 E06 669	PANEL ASSY UD2	W50	1	1							KB00R306G18		
136	S70 E08 669	PANEL ASSY UD2	W100									KB00R306G21		
137	S70 E10 669	PANEL ASSY UD2	W50(2)			1	1	1	1	1		KB00R306G22		
138	S70 E12 067	COVER ASSY		1	1	1	1	1	1	1		KB00M197G06		
139	S70 E13 068	COVER BOX ASSY		1	1	1	1	1	1	1		KB00T337G02		
140	S70 E55 500	FILTER	550	2	2							KD35J684G01		
141	S70 E70 500	FILTER	700			1	1	1	1	1		KD35J685G01		
142	S70 E90 500	FILTER	900			1	1	1	1	1		KD35J686G01		
143	S70 E16 524	PLUG	RUBBER	1	1	1	1	1	1	1		KB26H049H01		
144	S70 29H 523	SOCKET		1	1	1	1	1	1	1		BB25D449K01		
145	S70 E10 642	PANEL TOP ASSY	W20									KB00R292G06		

PEFY-W20,W25,W32,W40VMA(2)-A.UK EXTERNAL PARTS (1)
 PEFY-W50,W63,W71,W80VMA(2)-A.UK
 PEFY-W100,W125VMA(2)-A.UK

No.	Part No.	Part Name	Spec.	PEFY-W32VMA2-A.UK	PEFY-W40VMA2-A.UK	PEFY-W50VMA2-A.UK	PEFY-W63VMA2-A.UK	PEFY-W71VMA2-A.UK	PEFY-W80VMA2-A.UK	Dwg. No.	Notes for the models	Revision info.
146	S70 E60 642	PANEL TOP ASSY	W40							KB00R292G13		
147	S70 E30 642	PANEL TOP ASSY	W50	1	1					KB00R292G08		
148	S70 E40 642	PANEL TOP ASSY	W100							KB00R292G11		
149	S70 E50 642	PANEL TOP ASSY	W50(2)			1	1	1	1	KB00R292G12		

PEFY-W20,W25,W32,W40VMA(2)-A.UK
 PEFY-W50,W63,W71,W80VMA(2)-A.UK
 PEFY-W100,W125VMA(2)-A.UK

EXTERNAL PARTS (1)

No.	Part No.	Part Name	Spec.	PEFY-W100VMA2-A.UK	PEFY-W125VMA2-A.UK					Dwg. No.	Notes for the models	Revision info.
101	S70 W01 480	HEAT EXCHANGER								KB00Y431B03		Chg.
102	S70 W02 480	HEAT EXCHANGER								KB00Y431B04		Chg.
103	S70 W03 480	HEAT EXCHANGER								KB00Y430B02		Chg.
104	S70 W04 480	HEAT EXCHANGER								KB00Y429B02		Chg.
105	S70 W05 480	HEAT EXCHANGER								KB00Y428B02		Chg.
106	S70 W06 480	HEAT EXCHANGER								KB00Y427B03		Chg.
107	S70 W07 480	HEAT EXCHANGER		1	1					KB00Y427B04		Chg.
108	S70 100 202	THERMISTOR		1	1					KB71B945M01		
109	S70 W40 151	AIR PURGE VALVE		1	1					BT50C889H01		
110	S70 W10 111	TUBE	PVC	1	1					BG27L986H63		
111	S70 W10 208	PRES.SENSOR	IN	1	1					KR51C556H01		
112	S70 W20 208	PRES.SENSOR	OUT	1	1					KR51C558H01		
113	S70 W10 406	2-WAY VALVE		1	1					KR50B237H01		
114	S70 W20 407	2-WAY VALVE CAP		1	1					KR32C548H01		
115	S70 W30 409	NIPPLE SET		2	2					KJ00M546G01	*1 Includes O-RING (2pcs.)	Chg.
116	S70 W30 465	FASTENER	12.7	2	2					KR20C549H01		
117	S70 C01 800	GREASE	100g	1	1					RG88D941K01	*2	
118	S70 W10 065	COVER PIPE ASSY 1		1	1					KJ00K354G01		
119	S70 W20 065	COVER PIPE ASSY 2		1	1					KJ00K343G01		
120	S70 0B2 355	PUMP	PMD	1	1					BH56B946H05		
121	S70 0B2 266	FLOAT SWITCH		1	1					BH68T992K01		
122	S70 E50 527	SOCKET ASSY		1	1					KB00R308G05		
123	S70 E10 529	DRAIN PAN ASSY	W20							KB00R237G01		
124	S70 E20 529	DRAIN PAN ASSY	W40							KB00R237G02		
125	S70 E30 529	DRAIN PAN ASSY	W50							KB00R237G03		
126	S70 E40 529	DRAIN PAN ASSY	W100							KB00R237G04		
127	S70 E50 529	DRAIN PAN ASSY	W50(2)	1	1					KB00R237G05		
128	S70 W01 669	PANEL ASSY UD1	W20							KL00R438G01		
129	S70 W02 669	PANEL ASSY UD1	W40							KL00R438G02		
130	S70 W03 669	PANEL ASSY UD1	W50							KL00R438G03		
131	S70 W04 669	PANEL ASSY UD1	W100							KL00R438G04		
132	S70 W05 669	PANEL ASSY UD1	W50(2)	1	1					KL00R438G05		
133	S70 E02 669	PANEL ASSY UD2	W20							KB00R306G16		
134	S70 E04 669	PANEL ASSY UD2	W40							KB00R306G17		
135	S70 E06 669	PANEL ASSY UD2	W50							KB00R306G18		
136	S70 E08 669	PANEL ASSY UD2	W100							KB00R306G21		
137	S70 E10 669	PANEL ASSY UD2	W50(2)	1	1					KB00R306G22		
138	S70 E12 067	COVER ASSY		1	1					KB00M197G06		
139	S70 E13 068	COVER BOX ASSY		1	1					KB00T337G02		
140	S70 E55 500	FILTER	550							KD35J684G01		
141	S70 E70 500	FILTER	700	1	1					KD35J685G01		
142	S70 E90 500	FILTER	900	1	1					KD35J686G01		
143	S70 E16 524	PLUG	RUBBER	1	1					KB26H049H01		
144	S70 29H 523	SOCKET		1	1					BB25D449K01		
145	S70 E10 642	PANEL TOP ASSY	W20							KB00R292G06		

PEFY-W20,W25,W32,W40VMA(2)-A.UK EXTERNAL PARTS (1)
PEFY-W50,W63,W71,W80VMA(2)-A.UK
PEFY-W100,W125VMA(2)-A.UK

No.	Part No.	Part Name	Spec.	PEFY-W100VMA(2)-A.UK	PEFY-W125VMA(2)-A.UK					Dwg. No.	Notes for the models	Revision info.
146	S70 E60 642	PANEL TOP ASSY	W40							KB00R292G13		
147	S70 E30 642	PANEL TOP ASSY	W50							KB00R292G08		
148	S70 E40 642	PANEL TOP ASSY	W100							KB00R292G11		
149	S70 E50 642	PANEL TOP ASSY	W50(2)	1	1					KB00R292G12		

PEFY-W20,W25,W32,W40VMAL-A.UK
 PEFY-W50,W63,W71,W80VMAL-A.UK
 PEFY-W100,W125VMAL-A.UK

EXTERNAL PARTS (2)

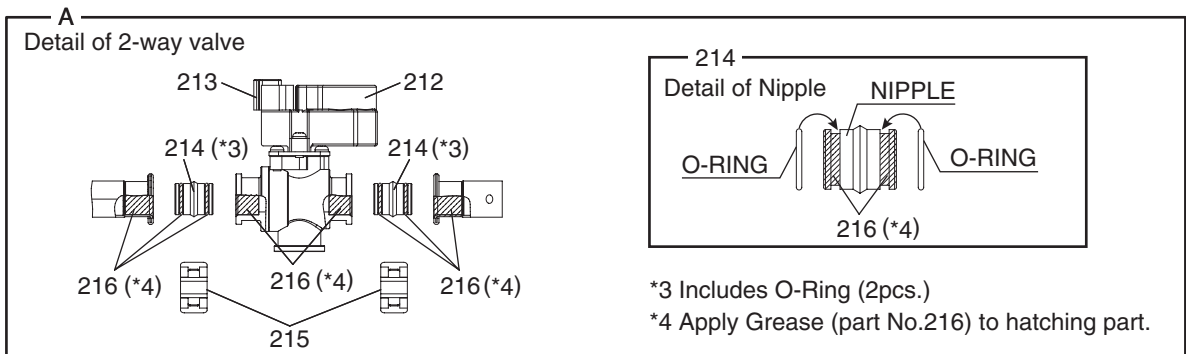
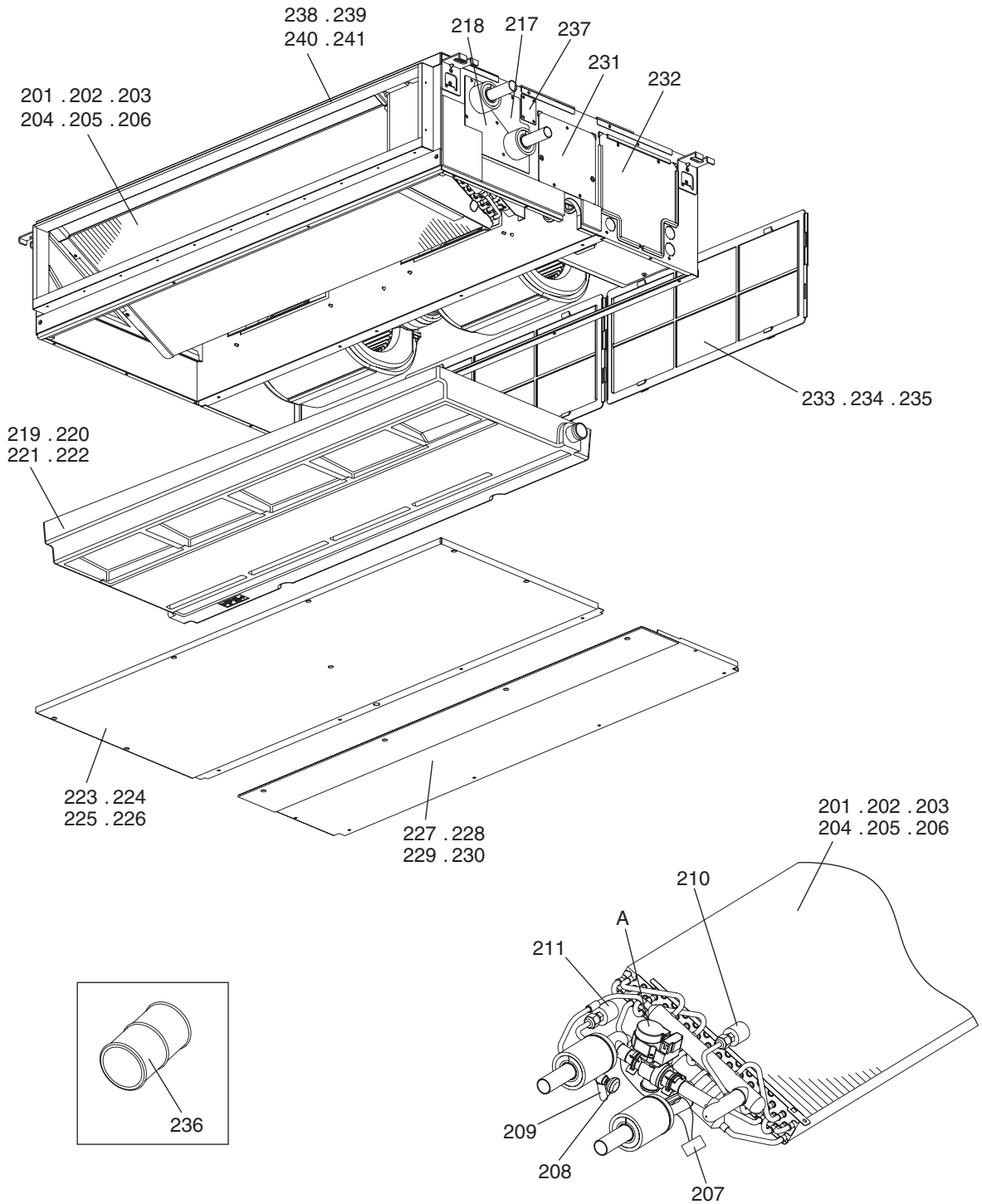

PEFY-W20,W25,W32,W40VMAL-A.UK
 PEFY-W50,W63,W71,W80VMAL-A.UK
 PEFY-W100,W125VMAL-A.UK

EXTERNAL PARTS (2)

No.	Part No.	Part Name	Spec.	PEFY-W20VMAL-A.UK	PEFY-W25VMAL-A.UK	PEFY-W32VMAL-A.UK	PEFY-W40VMAL-A.UK	PEFY-W50VMAL-A.UK	PEFY-W63VMAL-A.UK	PEFY-W71VMAL-A.UK	PEFY-W80VMAL-A.UK	Dwg. No.	Notes for the models	Revision info.
201	S70 W01 480	HEAT EXCHANGER		1	1							KB00Y431B03		Chg.
202	S70 W02 480	HEAT EXCHANGER				1						KB00Y431B04		Chg.
203	S70 W03 480	HEAT EXCHANGER					1					KB00Y430B02		Chg.
204	S70 W04 480	HEAT EXCHANGER						1	1			KB00Y429B02		Chg.
205	S70 W05 480	HEAT EXCHANGER										KB00Y428B02		Chg.
206	S70 W06 480	HEAT EXCHANGER										KB00Y427B03		Chg.
207	S70 100 202	THERMISTOR		1	1	1	1	1	1	1	1	KB71B945M01		
208	S70 W40 151	AIR PURGE VALVE		1	1	1	1	1	1	1	1	BT50C889H01		
209	S70 W10 111	TUBE	PVC	1	1	1	1	1	1	1	1	BG27L986H63		
210	S70 W10 208	PRES.SENSOR	IN	1	1	1	1	1	1	1	1	KR51C556H01		
211	S70 W20 208	PRES.SENSOR	OUT	1	1	1	1	1	1	1	1	KR51C558H01		
212	S70 W10 406	2-WAY VALVE		1	1	1	1	1	1	1	1	KR50B237H01		
213	S70 W20 407	2-WAY VALVE CAP		1	1	1	1	1	1	1	1	KR32C548H01		
214	S70 W30 409	NIPPLE SET		2	2	2	2	2	2	2	2	KJ00M546G01	*3 Includes O-RING (2pcs.)	Chg.
215	S70 W30 465	FASTENER	12.7	2	2	2	2	2	2	2	2	KR20C549H01		
216	S70 C01 800	GREASE	100g	1	1	1	1	1	1	1	1	RG88D941K01	*4	
217	S70 W10 065	COVER PIPE ASSY 1		1	1	1	1	1	1	1	1	KJ00K354G01		
218	S70 W20 065	COVER PIPE ASSY 2		1	1	1	1	1	1	1	1	KJ00K343G01		
219	S70 E10 529	DRAIN PAN ASSY	W20	1	1	1						KB00R237G01		
220	S70 E20 529	DRAIN PAN ASSY	W40				1					KB00R237G02		
221	S70 E30 529	DRAIN PAN ASSY	W50					1	1			KB00R237G03		
222	S70 E40 529	DRAIN PAN ASSY	W100									KB00R237G04		
223	S70 W01 669	PANEL ASSY UD1	W20	1	1	1						KL00R438G01		
224	S70 W02 669	PANEL ASSY UD1	W40				1					KL00R438G02		
225	S70 W03 669	PANEL ASSY UD1	W50					1	1			KL00R438G03		
226	S70 W04 669	PANEL ASSY UD1	W100									KL00R438G04		
227	S70 E02 669	PANEL ASSY UD2	W20	1	1	1						KB00R306G16		
228	S70 E04 669	PANEL ASSY UD2	W40				1					KB00R306G17		
229	S70 E06 669	PANEL ASSY UD2	W50					1	1			KB00R306G18		
230	S70 E08 669	PANEL ASSY UD2	W100									KB00R306G21		
231	S70 E12 067	COVER ASSY		1	1	1	1	1	1	1	1	KB00M197G06		
232	S70 E13 068	COVER BOX ASSY		1	1	1	1	1	1	1	1	KB00T337G02		
233	S70 E55 500	FILTER	550					2	2			KD35J684G01		
234	S70 E70 500	FILTER	700	1	1	1						KD35J685G01		
235	S70 E90 500	FILTER	900				1					KD35J686G01		
236	S70 29H 523	SOCKET		1	1	1	1	1	1	1	1	BB25D449K01		
237	S70 E30 522	COVER SOCKET ASSY		1	1	1	1	1	1	1	1	KB00M268G02		
238	S70 E10 642	PANEL TOP ASSY	W20	1	1	1						KB00R292G06		
239	S70 E60 642	PANEL TOP ASSY	W40				1					KB00R292G13		
240	S70 E30 642	PANEL TOP ASSY	W50					1	1			KB00R292G08		
241	S70 E40 642	PANEL TOP ASSY	W100									KB00R292G11		

PEFY-W20,W25,W32,W40VMAL-A.UK
 PEFY-W50,W63,W71,W80VMAL-A.UK
 PEFY-W100,W125VMAL-A.UK

EXTERNAL PARTS (2)

No.	Part No.	Part Name	Spec.	PEFY-W20VMAL-A.UK	PEFY-W25VMAL-A.UK	PEFY-W32VMAL-A.UK	PEFY-W40VMAL-A.UK		Dwg. No.	Notes for the models	Revision info.
201	S70 W01 480	HEAT EXCHANGER							KB00Y431B03		Chg.
202	S70 W02 480	HEAT EXCHANGER							KB00Y431B04		Chg.
203	S70 W03 480	HEAT EXCHANGER							KB00Y430B02		Chg.
204	S70 W04 480	HEAT EXCHANGER		1	1				KB00Y429B02		Chg.
205	S70 W05 480	HEAT EXCHANGER				1			KB00Y428B02		Chg.
206	S70 W06 480	HEAT EXCHANGER					1		KB00Y427B03		Chg.
207	S70 100 202	THERMISTOR		1	1	1	1		KB71B945M01		
208	S70 W40 151	AIR PURGE VALVE		1	1	1	1		BT50C889H01		
209	S70 W10 111	TUBE	PVC	1	1	1	1		BG27L986H63		
210	S70 W10 208	PRES.SENSOR	IN	1	1	1	1		KR51C556H01		
211	S70 W20 208	PRES.SENSOR	OUT	1	1	1	1		KR51C558H01		
212	S70 W10 406	2-WAY VALVE		1	1	1	1		KR50B237H01		
213	S70 W20 407	2-WAY VALVE CAP		1	1	1	1		KR32C548H01		
214	S70 W30 409	NIPPLE SET		2	2	2	2		KJ00M546G01	*3 Includes O-RING (2pcs.)	Chg.
215	S70 W30 465	FASTENER	12.7	2	2	2	2		KR20C549H01		
216	S70 C01 800	GREASE	100g	1	1	1	1		RG88D941K01	*4	
217	S70 W10 065	COVER PIPE ASSY 1		1	1	1	1		KJ00K354G01		
218	S70 W20 065	COVER PIPE ASSY 2		1	1	1	1		KJ00K343G01		
219	S70 E10 529	DRAIN PAN ASSY	W20						KB00R237G01		
220	S70 E20 529	DRAIN PAN ASSY	W40						KB00R237G02		
221	S70 E30 529	DRAIN PAN ASSY	W50	1	1				KB00R237G03		
222	S70 E40 529	DRAIN PAN ASSY	W100			1	1		KB00R237G04		
223	S70 W01 669	PANEL ASSY UD1	W20						KL00R438G01		
224	S70 W02 669	PANEL ASSY UD1	W40						KL00R438G02		
225	S70 W03 669	PANEL ASSY UD1	W50	1	1				KL00R438G03		
226	S70 W04 669	PANEL ASSY UD1	W100			1	1		KL00R438G04		
227	S70 E02 669	PANEL ASSY UD2	W20						KB00R306G16		
228	S70 E04 669	PANEL ASSY UD2	W40						KB00R306G17		
229	S70 E06 669	PANEL ASSY UD2	W50	1	1				KB00R306G18		
230	S70 E08 669	PANEL ASSY UD2	W100			1	1		KB00R306G21		
231	S70 E12 067	COVER ASSY		1	1	1	1		KB00M197G06		
232	S70 E13 068	COVER BOX ASSY		1	1	1	1		KB00T337G02		
233	S70 E55 500	FILTER	550	2	2				KD35J684G01		
234	S70 E70 500	FILTER	700			2	2		KD35J685G01		
235	S70 E90 500	FILTER	900						KD35J686G01		
236	S70 29H 523	SOCKET		1	1	1	1		BB25D449K01		
237	S70 E30 522	COVER SOCKET ASSY		1	1	1	1		KB00M268G02		
238	S70 E10 642	PANEL TOP ASSY	W20						KB00R292G06		
239	S70 E60 642	PANEL TOP ASSY	W40						KB00R292G13		
240	S70 E30 642	PANEL TOP ASSY	W50	1	1				KB00R292G08		
241	S70 E40 642	PANEL TOP ASSY	W100			1	1		KB00R292G11		

PEFY-W20,W25,W32,W40VMA(L)-A.UK
PEFY-W50,W63,W71,W80VMA(L)-A.UK
PEFY-W20,W25,W32,W40VMA2-A.UK

BLOWER PARTS (1)

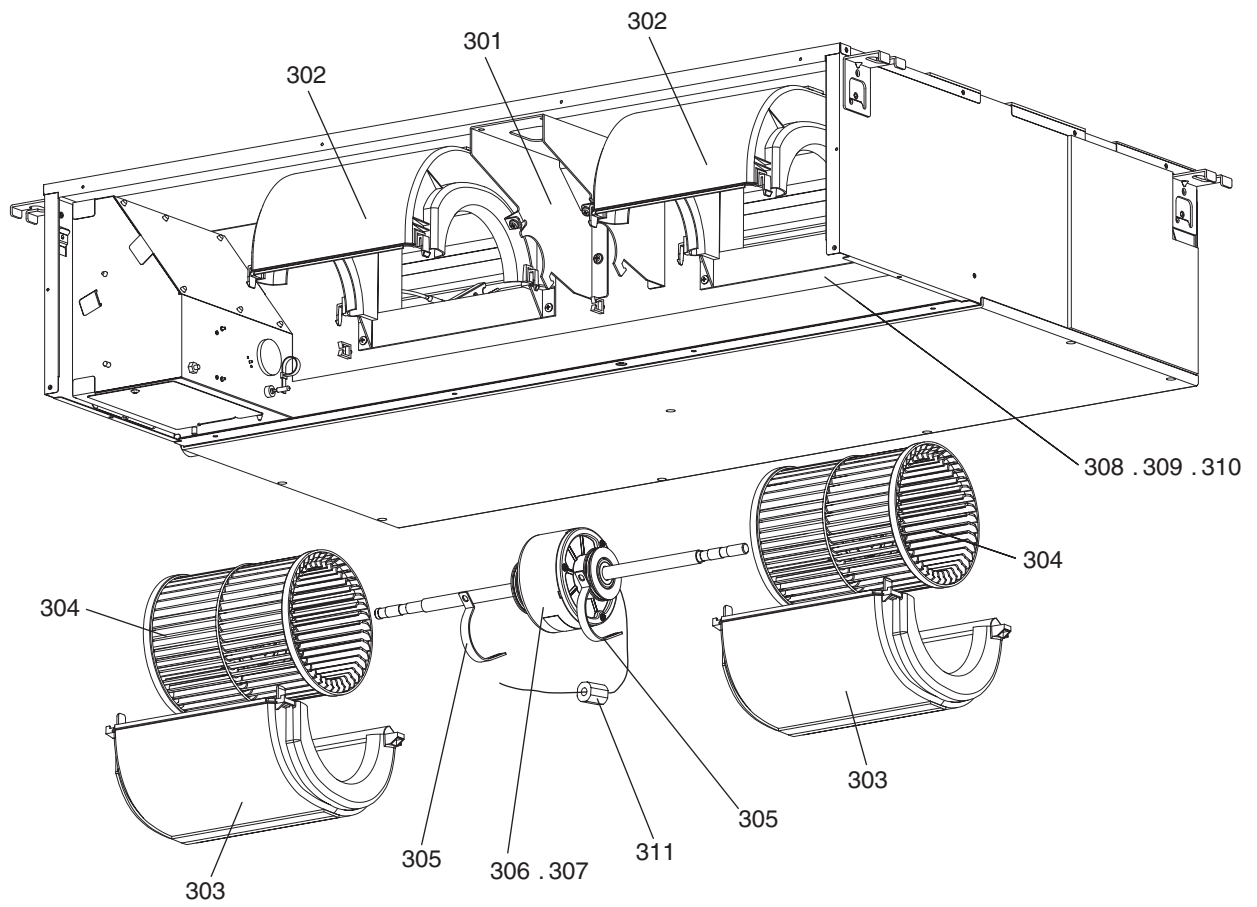

PEFY-W20,W25,W32,W40VMA(L)-A.UK
PEFY-W50,W63,W71,W80VMA(L)-A.UK
PEFY-W20,W25,W32,W40VMA2-A.UK

BLOWER PARTS (1)

No.	Part No.	Part Name	Spec.	PEFY-W20VMA-A.UK	PEFY-W25VMA-A.UK	PEFY-W32VMA-A.UK	PEFY-W40VMA-A.UK	PEFY-W50VMA-A.UK	PEFY-W63VMA-A.UK	Dwg. No.	Notes for the models	Revision info.
301	S70 E65 130	MOTOR BASE	W20	1	1	1	1	1	1	KD02J553H01		
302	S70 E60 110	FAN CASE U ASSY		1	1	1	2	2	2	KJ00K474G01		
303	S70 E62 110	FAN CASE L ASSY		1	1	1	2	2	2	KJ00K473G01		
304	S70 E35 114	SIROCCO FAN ASSY		1	1	1	2	2	2	KL00R388G01		
305	S70 E10 131	ATTACHMENT		2	2	2	2	2	2	W353715H01		
306	S70 E15 220	MOTOR	W20	1	1	1				KR61B238H01		
307	S70 E25 220	MOTOR	W40				1	1	1	KR61B239H01		
308	S70 E15 677	FAN PLATE ASSY	W20	1	1	1				KB00T067G21		
309	S70 E25 677	FAN PLATE ASSY	W40				1			KB00T067G22		
310	S70 E35 677	FAN PLATE ASSY	W50					1	1	KB00T067G23		
311	S70 050 292	CLAMP FERRITE FOB		1	1	1	1	1	1	KR65C297H03		

PEFY-W20,W25,W32,W40VMA(L)-A.UK
 PEFY-W50,W63,W71,W80VMA(L)-A.UK
 PEFY-W20,W25,W32,W40VMA2-A.UK

BLOWER PARTS (1)

No.	Part No.	Part Name	Spec.	PEFY-W20VMA(L)-A.UK	PEFY-W25VMA(L)-A.UK	PEFY-W32VMA(L)-A.UK	PEFY-W40VMA(L)-A.UK	PEFY-W50VMA(L)-A.UK	PEFY-W63VMA(L)-A.UK	PEFY-W71VMA(L)-A.UK	PEFY-W80VMA(L)-A.UK	Dwg. No.	Notes for the models	Revision info.
301	S70 E65 130	MOTOR BASE	W20	1	1	1	1	1	1	1	1	KD02J553H01		
302	S70 E60 110	FAN CASE U ASSY		2	2	2	2	2	2	2	2	KJ00K474G01		
303	S70 E62 110	FAN CASE L ASSY		2	2	2	2	2	2	2	2	KJ00K473G01		
304	S70 E35 114	SIROCCO FAN ASSY		2	2	2	2	2	2	2	2	KL00R388G01		
305	S70 E10 131	ATTACHMENT		2	2	2	2	2	2	2	2	W353715H01		
306	S70 E15 220	MOTOR	W20									KR61B238H01		
307	S70 E25 220	MOTOR	W40	1	1	1	1	1	1	1	1	KR61B239H01		
308	S70 E15 677	FAN PLATE ASSY	W20									KB00T067G21		
309	S70 E25 677	FAN PLATE ASSY	W40									KB00T067G22		
310	S70 E35 677	FAN PLATE ASSY	W50	1	1	1	1	1	1	1	1	KB00T067G23		
311	S70 050 292	CLAMP FERRITE FOB		1	1	1	1	1	1	1	1	KR65C297H03		

PEFY-W100,W125VMA(L)-A.UK
PEFY-W50,W63,W71VMA2-A.UK
PEFY-W80,W100,W125VMA2-A.UK

BLOWER PARTS (2)

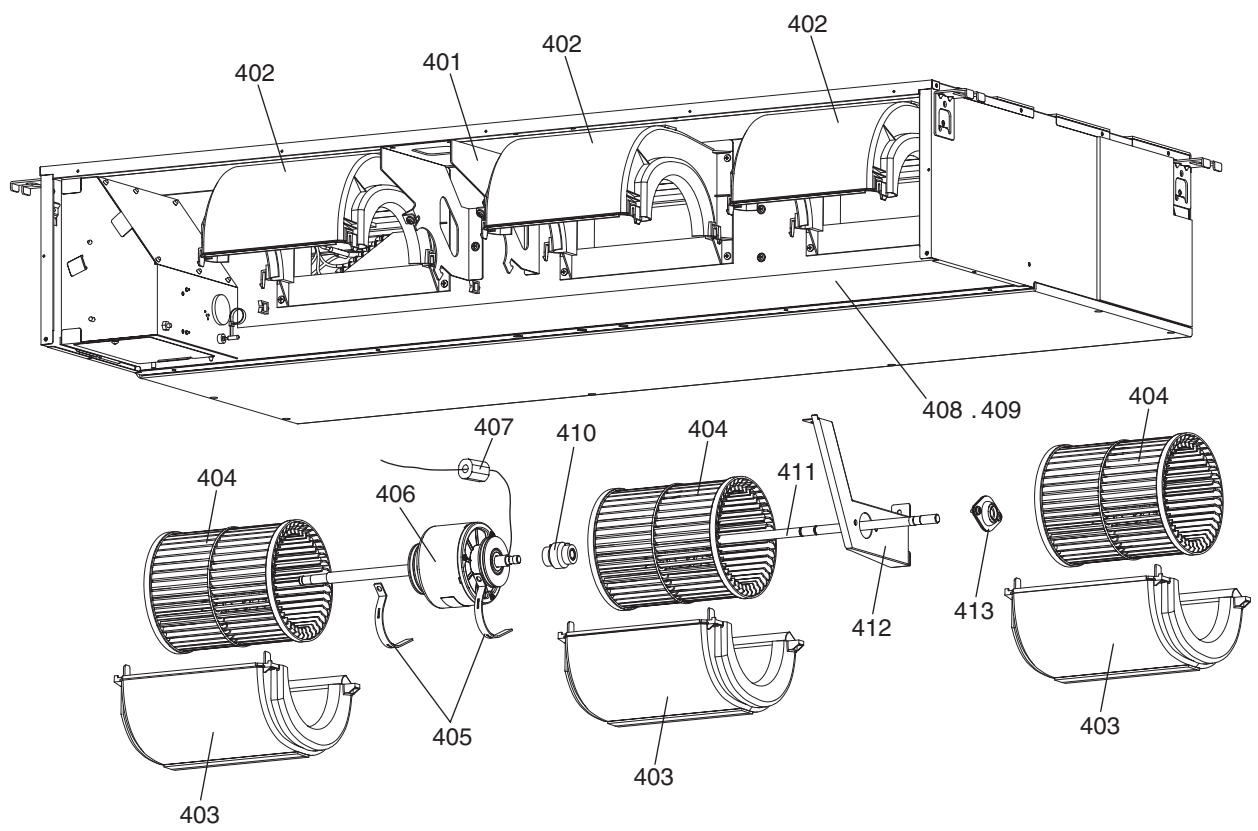

PEFY-W20,W25,W32,W40VMA(2)(L)-A.UK
PEFY-W50,W63,W71,W80VMA(2)(L)-A.UK
PEFY-W100,W125VMA(2)(L)-A.UK

CONTROL BOX PARTS

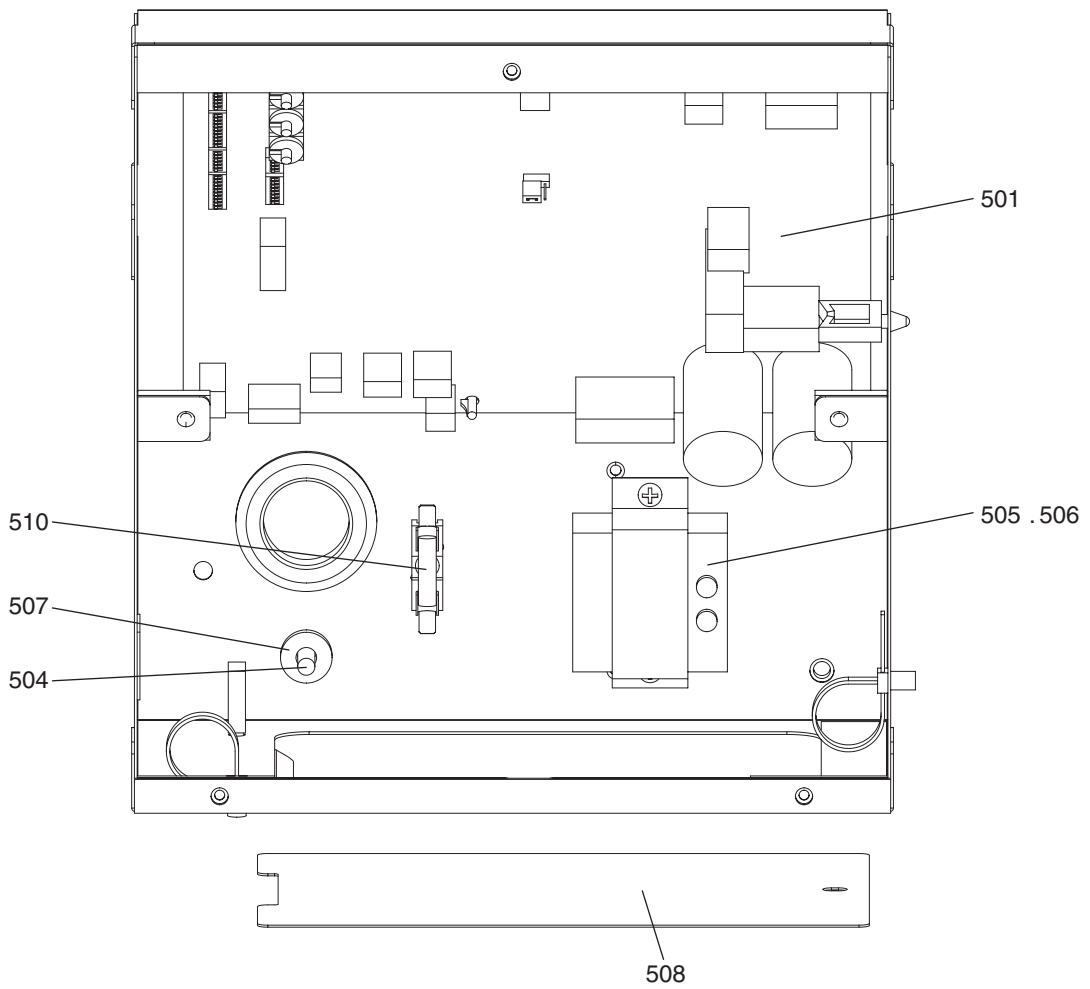
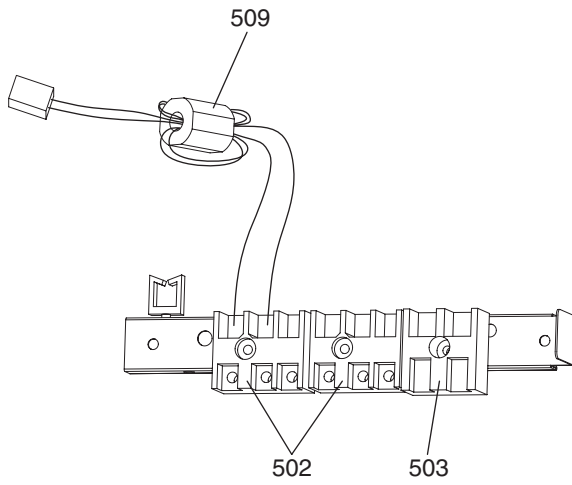

PEFY-W20,W25,W32,W40VMA(2)(L)-A.UK CONTROL BOX PARTS
PEFY-W50,W63,W71,W80VMA(2)(L)-A.UK
PEFY-W100,W125VMA(2)(L)-A.UK

No.	Part No.	Part Name	Spec.	PEFY-W20VMA-A.UK	PEFY-W25VMA-A.UK	PEFY-W32VMA-A.UK	PEFY-W40VMA-A.UK	PEFY-W50VMA-A.UK	PEFY-W63VMA-A.UK	Dwg. No.	Notes for the models	Revision info.
501	S70 K90 310	PRINTED CIRCUIT ASSEMBLY		1	1	1	1	1	1	KE01H089B01		
502	S70 0B4 716	TERMINAL BLOCK ASSY		2	2	2	2	2	2	BH00C267G09		
503	S70 E40 716	TERMINAL BLOCK		1	1	1	1	1	1	BH73L021H01		
504	S70 0B1 202	THERMISTOR-S	250XAP	1	1	1	1	1	1	RG71J628H01		
505	S70 K10 259	REACTOR	3A3	1	1	1	1			KR65C559H01		
506	S70 K11 259	REACTOR	3A6					1	1	KR65C489H01		
507	S70 E10 306	CORD BUSH		1	1	1	1	1	1	BG25U730H01		
508	S70 E14 068	BOX UNDER COVER		1	1	1	1	1	1	KB02K887Z01		
509	S70 050 292	CLAMP FERRITE FOB		1	1	1	1	1	1	KR65C297H03		
510	S70 610 239	FUSE	SHV12 3A	1	1	1	1	1	1	KR75C422H01		

PEFY-W20,W25,W32,W40VMA(2)(L)-A.UK
PEFY-W50,W63,W71,W80VMA(2)(L)-A.UK
PEFY-W100,W125VMA(2)(L)-A.UK

CONTROL BOX PARTS

No.	Part No.	Part Name	Spec.	PEFY-W71VMA-A.UK	PEFY-W80VMA-A.UK	PEFY-W100VMA-A.UK	PEFY-W125VMA-A.UK	PEFY-W20VMA(2)(L)-A.UK	PEFY-W25VMA(2)(L)-A.UK	Dwg. No.	Notes for the models	Revision info.
501	S70 K90 310	PRINTED CIRCUIT ASSEMBLY		1	1	1	1	1	1	KE01H089B01		
502	S70 0B4 716	TERMINAL BLOCK ASSY		2	2	2	2	2	2	BH00C267G09		
503	S70 E40 716	TERMINAL BLOCK		1	1	1	1	1	1	BH73L021H01		
504	S70 0B1 202	THERMISTOR-S	250XAP	1	1	1	1	1	1	RG71J628H01		
505	S70 K10 259	REACTOR	3A3						1	1	KR65C559H01	
506	S70 K11 259	REACTOR	3A6	1	1	1	1				KR65C489H01	
507	S70 E10 306	CORD BUSH		1	1	1	1	1	1	BG25U730H01		
508	S70 E14 068	BOX UNDER COVER		1	1	1	1	1	1	KB02K887Z01		
509	S70 050 292	CLAMP FERRITE FOB		1	1	1	1	1	1	KR65C297H03		
510	S70 610 239	FUSE	SHV12 3A	1	1	1	1	1	1	KR75C422H01		

PEFY-W20,W25,W32,W40VMA(2)(L)-A.UK CONTROL BOX PARTS
 PEFY-W50,W63,W71,W80VMA(2)(L)-A.UK
 PEFY-W100,W125VMA(2)(L)-A.UK

No.	Part No.	Part Name	Spec.	PEFY-W20,W25,W32,W40VMA(2)(L)-A.UK						Dwg. No.	Notes for the models	Revision info.
				PEFY-W50,W63,W71,W80VMA(2)(L)-A.UK	PEFY-W100,W125VMA(2)(L)-A.UK	PEFY-W20,W25,W32,W40VMA(2)(L)-A.UK	PEFY-W50,W63,W71,W80VMA(2)(L)-A.UK	PEFY-W100,W125VMA(2)(L)-A.UK	PEFY-W20,W25,W32,W40VMA(2)(L)-A.UK			
501	S70 K90 310	PRINTED CIRCUIT ASSEMBLY		1	1	1	1	1	1	KE01H089B01		
502	S70 0B4 716	TERMINAL BLOCK ASSY		2	2	2	2	2	2	BH00C267G09		
503	S70 E40 716	TERMINAL BLOCK		1	1	1	1	1	1	BH73L021H01		
504	S70 0B1 202	THERMISTOR-S	250XAP	1	1	1	1	1	1	RG71J628H01		
505	S70 K10 259	REACTOR	3A3	1	1					KR65C559H01		
506	S70 K11 259	REACTOR	3A6			1	1	1	1	KR65C489H01		
507	S70 E10 306	CORD BUSH		1	1	1	1	1	1	BG25U730H01		
508	S70 E14 068	BOX UNDER COVER		1	1	1	1	1	1	KB02K887Z01		
509	S70 050 292	CLAMP FERRITE FOB		1	1	1	1	1	1	KR65C297H03		
510	S70 610 239	FUSE	SHV12 3A	1	1	1	1	1	1	KR75C422H01		

No.	Part No.	Part Name	Spec.	PEFY-W100VMA(L)-A.UK	PEFY-W125VMA(L)-A.UK	PEFY-W20VMA2(L)-A.UK	PEFY-W25VMA2(L)-A.UK	PEFY-W32VMA2(L)-A.UK	PEFY-W40VMA2(L)-A.UK	Dwg. No.	Notes for the models	Revision info.
501	S70 K90 310	PRINTED CIRCUIT ASSEMBLY		1	1	1	1	1	1	KE01H089B01		
502	S70 0B4 716	TERMINAL BLOCK ASSY		2	2	2	2	2	2	BH00C267G09		
503	S70 E40 716	TERMINAL BLOCK		1	1	1	1	1	1	BH73L021H01		
504	S70 0B1 202	THERMISTOR-S	250XAP	1	1	1	1	1	1	RG71J628H01		
505	S70 K10 259	REACTOR	3A3							KR65C559H01		
506	S70 K11 259	REACTOR	3A6	1	1	1	1	1	1	KR65C489H01		
507	S70 E10 306	CORD BUSH		1	1	1	1	1	1	BG25U730H01		
508	S70 E14 068	BOX UNDER COVER		1	1	1	1	1	1	KB02K887Z01		
509	S70 050 292	CLAMP FERRITE FOB		1	1	1	1	1	1	KR65C297H03		
510	S70 610 239	FUSE	SHV12 3A	1	1	1	1	1	1	KR75C422H01		

No.	Part No.	Part Name	Spec.							Dwg. No.	Notes for the models	Revision info.	
				PEFY-W20VMA(2)(L)-A.UK	PEFY-W25VMA(2)(L)-A.UK	PEFY-W32VMA(2)(L)-A.UK	PEFY-W40VMA(2)(L)-A.UK	PEFY-W50VMA(2)(L)-A.UK	PEFY-W63VMA(2)(L)-A.UK				PEFY-W71VMA(2)(L)-A.UK
501	S70 K90 310	PRINTED CIRCUIT ASSEMBLY		1	1	1	1	1	1	1	KE01H089B01		
502	S70 0B4 716	TERMINAL BLOCK ASSY		2	2	2	2	2	2	2	BH00C267G09		
503	S70 E40 716	TERMINAL BLOCK		1	1	1	1	1	1	1	BH73L021H01		
504	S70 0B1 202	THERMISTOR-S	250XAP	1	1	1	1	1	1	1	RG71J628H01		
505	S70 K10 259	REACTOR	3A3								KR65C559H01		
506	S70 K11 259	REACTOR	3A6	1	1	1	1	1	1	1	KR65C489H01		
507	S70 E10 306	CORD BUSH		1	1	1	1	1	1	1	BG25U730H01		
508	S70 E14 068	BOX UNDER COVER		1	1	1	1	1	1	1	KB02K887Z01		
509	S70 050 292	CLAMP FERRITE FOB		1	1	1	1	1	1	1	KR65C297H03		
510	S70 610 239	FUSE	SHV12 3A	1	1	1	1	1	1	1	KR75C422H01		

mitsubishi
MITSUBISHI ELECTRIC CORPORATION

BWE01842A (20191031)