

AIR CONDITIONING SYSTEMS

HYBRID
CITY MULTI

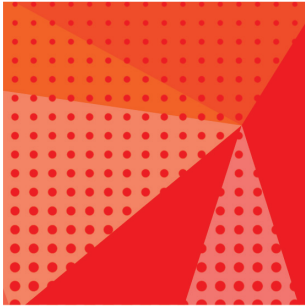

DATA BOOK

MODEL

PEFY-WP-VMS1-E



PEFY-WP-VMS1-E

1. SPECIFICATIONS	2
2. EXTERNAL DIMENSIONS	4
3. CENTER OF GRAVITY	6
4. ELECTRICAL WIRING DIAGRAMS	7
5. SOUND LEVELS	8
5-1. Sound levels	8
5-2. NC curves	9
6. FAN CHARACTERISTICS CURVES.....	12
7. ELECTRICAL CHARACTERISTICS.....	17
8. OPTIONAL PARTS.....	18
8-1. Optional parts line up for the Indoor unit.....	18
8-2. Control box replace kit	19
8-3. Plasma Quad Connect.....	20

1. SPECIFICATIONS

Ceiling concealed (Low static pressure type)

PEFY-WP-VMS1-E

Model			PEFY-WP10VMS1-E	PEFY-WP15VMS1-E	PEFY-WP20VMS1-E	PEFY-WP25VMS1-E	
Power source			1-phase 220-230-240 V 50/60 Hz	1-phase 220-230-240 V 50/60 Hz	1-phase 220-230-240 V 50/60 Hz	1-phase 220-230-240 V 50/60 Hz	
Cooling capacity (Nominal)	*1	kW	1.2	1.7	2.2	2.8	
	*1	BTU/h	4,100	5,800	7,500	9,600	
(220V)	*2	Power input	0.030	0.050	0.051	0.060	
	*2	Current input	A	0.21	0.44	0.51	
Heating capacity (Nominal)	*3	kW	1.4	1.9	2.5	3.2	
	*3	BTU/h	4,800	6,500	8,500	10,900	
(220V)	*2	Power input	0.030	0.030	0.031	0.040	
	*2	Current input	A	0.21	0.38	0.40	
External finish			Galvanized steel plate	Galvanized steel plate	Galvanized steel plate	Galvanized steel plate	
External dimension H × W × D			mm	200 x 790 x 700	200 x 790 x 700	200 x 790 x 700	
			in.	7-7/8 x 31-1/8 x 27-9/16	7-7/8 x 31-1/8 x 27-9/16	7-7/8 x 31-1/8 x 27-9/16	7-7/8 x 31-1/8 x 27-9/16
Net weight			kg (lbs)	19 (42)	19 (42)	20 (45)	
Heat exchanger			Cross fin (Aluminum fin and copper tube)				
			Water Volume	L	0.4	0.7	0.9
FAN			Sirocco fan x 2				
*4	Type × Quantity		Sirocco fan x 2				
	External static press.	Pa	<5> - 15 - <35> - <50>	<5> - 15 - <35> - <50>	<5> - 15 - <35> - <50>	<5> - 15 - <35> - <50>	
mmH ₂ O		<0.5> - 1.5 - <3.6> - <5.1>	<0.5> - 1.5 - <3.6> - <5.1>	<0.5> - 1.5 - <3.6> - <5.1>	<0.5> - 1.5 - <3.6> - <5.1>		
Motor Type			DC motor				
Motor output			kW				
Driving mechanism			Direct-driven by motor				
Air flow rate			(Low-Mid-High)				
			m ³ /min	4.0 - 4.5 - 5.0	5.0 - 6.0 - 7.0	5.5 - 6.5 - 8.0	5.5 - 7.0 - 9.0
			L/s	67 - 75 - 83	83 - 100 - 117	92 - 108 - 133	92 - 117 - 150
			cfm	141 - 159 - 177	177 - 212 - 247	194 - 230 - 282	194 - 247 - 318
Sound pressure level (measured in anechoic room)			(Low-Mid-High)				
*2			dB <A>				
Insulation material			EPS, Polyethylene foam, Urethane foam				
Air filter			PP honeycomb fabric.				
Protection device			Fuse				
Refrigerant control device			-				
Connectable HBC			CMB-WM-V-AA, CMB-WM-F-AA, CMB-WM-V-BB				
Water piping diameter *5, 6							
Connection size	Inlet	in.	Rc 3/4 screw				
	Outlet	in.	Rc 3/4 screw				
Field pipe size	Inlet	mm I.D.	20				
	Outlet	mm I.D.	20				
Field drain pipe size			mm (in.)				
Drawing	External		KD94T794				
	Wiring		KD94T793				
	Refrigerant cycle		-				
Standard attachment	Document		Installation Manual, Instruction Book				
	Accessory		Insulation pipe for water pipe, Washer, Drain hose, Tie band				
Optional parts	Control Box Replace kit		PAC-KE70HS-E				
	Plasma Quad Connect		MAC-100FT-E				
	PQ attachment		PAC-HA11PAR				
Remarks			* Details on foundation work, duct work, insulation work, electrical wiring, power source switch, and other items shall be referred to the Installation Manual. * Due to continuing improvement, above specifications may be subject to change without notice.				

Notes:	Unit converter
1. Nominal cooling conditions Indoor: 27°C D.B./19°C W.B. (81°F D.B./66°F W.B.), Outdoor: 35°C D.B. (95°F D.B.) Pipe length: 7.5 m (24-9/16 ft.), Level difference: 0 m (0 ft.)	BTU/h = kW × 3,412
2. The values are measured at the factory setting of external static pressure.	cfm = m ³ /min × 35.31
3. Nominal heating conditions Indoor: 20°C D.B. (68°F D.B.), Outdoor: 7°C D.B./6°C W.B. (45°F D.B./43°F W.B.) Pipe length: 7.5 m (24-9/16 ft.), Level difference: 0 m (0 ft.)	lbs = kg/0.4536
4. The factory setting of external static pressure is shown without < >. Refer to "Fan characteristics curves", according to the external static pressure, in DATA BOOK for the usable range of air flow rate.	
5. Be sure to install a valve on the water outlet.	
6. Install a strainer (40 mesh or more) on the pipe next to the valve to remove the foreign matters.	*Above specification data is subject to rounding variation.
7. Please group units that operate on 1 branch.	

1. SPECIFICATIONS

Ceiling concealed (Low static pressure type)

Model			PEFY-WP32VMS1-E	PEFY-WP40VMS1-E	PEFY-WP50VMS1-E	
Power source			1-phase 220-230-240 V 50/60 Hz	1-phase 220-230-240 V 50/60 Hz	1-phase 220-230-240 V 50/60 Hz	
Cooling capacity (Nominal)	*1	kW	3.6	4.5	5.6	
	*1	BTU/h	12,300	15,400	19,100	
(220V)	*2	Power input	0.071	0.090	0.090	
	*2	Current input	A	0.73	0.77	
Heating capacity (Nominal)	*3	kW	4.0	5.0	6.3	
	*3	BTU/h	13,600	17,100	21,500	
(220V)	*2	Power input	kW	0.070	0.070	
	*2	Current input	A	0.50	0.66	
External finish			Galvanized steel plate	Galvanized steel plate	Galvanized steel plate	
External dimension H × W × D			mm	200 x 990 x 700	200 x 990 x 700	
			in.	7-7/8 x 39 x 27-9/16	7-7/8 x 39 x 27-9/16	
Net weight			kg (lbs)	25 (56)	27 (60)	
Heat exchanger			Cross fin (Aluminum fin and copper tube)	Cross fin (Aluminum fin and copper tube)	Cross fin (Aluminum fin and copper tube)	
Water Volume			L	1.0	1.7	
FAN	Type × Quantity		Sirocco fan x 3	Sirocco fan x 3	Sirocco fan x 4	
	*4	External static press.	Pa	<5> - 15 - <35> - <50>	<5> - 15 - <35> - <50>	<5> - 15 - <35> - <50>
			mmH ₂ O	<0.5> - 1.5 - <3.6> - <5.1>	<0.5> - 1.5 - <3.6> - <5.1>	<0.5> - 1.5 - <3.6> - <5.1>
	Motor Type		DC motor	DC motor	DC motor	
	Motor output		kW	0.096	0.096	
	Driving mechanism		Direct-driven by motor	Direct-driven by motor	Direct-driven by motor	
	Air flow rate		(Low-Mid-High)	(Low-Mid-High)	(Low-Mid-High)	
m ³ /min			8.0 - 9.0 - 11.0	9.5 - 11.0 - 13.0	12.0 - 14.0 - 16.5	
L/s			133 - 150 - 183	158 - 183 - 217	200 - 233 - 275	
		cfm	282 - 318 - 388	335 - 388 - 459	424 - 494 - 583	
Sound pressure level (measured in anechoic room)			(Low-Mid-High)	(Low-Mid-High)	(Low-Mid-High)	
			*2	dB <A>	28.0-30.0-33.0	
Insulation material			EPS, Polyethylene foam, Urethane foam	EPS, Polyethylene foam, Urethane foam	EPS, Polyethylene foam, Urethane foam	
Air filter			PP honeycomb fabric.	PP honeycomb fabric.	PP honeycomb fabric.	
Protection device			Fuse	Fuse	Fuse	
Refrigerant control device			-	-	-	
Connectable HBC			CMB-WM-V-AA, CMB-WM-F-AA, CMB-WM-V-BB	CMB-WM-V-AA, CMB-WM-F-AA, CMB-WM-V-BB	CMB-WM-V-AA, CMB-WM-F-AA, CMB-WM-V-BB	
Water piping diameter *5, 6						
Connection size	Inlet	in.	Rc 3/4 screw	Rc 3/4 screw	Rc 3/4 screw	
	Outlet	in.	Rc 3/4 screw	Rc 3/4 screw	Rc 3/4 screw	
Field pipe size	Inlet	mm I.D.	20	20	20	
	Outlet	mm I.D.	20	20	20	
Field drain pipe size			mm (in.)	O.D.32 (1-1/4)	O.D.32 (1-1/4)	
Drawing	External		KD94T794	KD94T794	KD94T794	
	Wiring		KD94T793	KD94T793	KD94T793	
	Refrigerant cycle		-	-	-	
Standard attachment	Document		Installation Manual, Instruction Book	Installation Manual, Instruction Book	Installation Manual, Instruction Book	
	Accessory		Insulation pipe for water pipe, Washer, Drain hose, Tie band	Insulation pipe for water pipe, Washer, Drain hose, Tie band	Insulation pipe for water pipe, Washer, Drain hose, Tie band	
Optional parts	Control Box Replace kit		PAC-KE70HS-E	PAC-KE70HS-E	PAC-KE70HS-E	
	Plasma Quad Connect		MAC-100FT-E	MAC-100FT-E	MAC-100FT-E	
	PQ attachment		PAC-HA11PAR	PAC-HA11PAR	PAC-HA11PAR	
Remarks			* Details on foundation work, duct work, insulation work, electrical wiring, power source switch, and other items shall be referred to the Installation Manual. * Due to continuing improvement, above specifications may be subject to change without notice.			

Notes:	Unit converter
1. Nominal cooling conditions Indoor: 27°C.D.B./19°C.W.B. (81°F.D.B./66°F.W.B.), Outdoor: 35°C.D.B. (95°F.D.B.) Pipe length: 7.5 m (24-9/16 ft.), Level difference: 0 m (0 ft.)	BTU/h =kW x 3,412
2. The values are measured at the factory setting of external static pressure.	cfm =m ³ /min x 35.31
3. Nominal heating conditions Indoor: 20°C.D.B. (68°F.D.B.), Outdoor: 7°C.D.B./6°C.W.B. (45°F.D.B./43°F.W.B.) Pipe length: 7.5 m (24-9/16 ft.), Level difference: 0 m (0 ft.)	lbs =kg/0.4536
4. The factory setting of external static pressure is shown without < > . Refer to "Fan characteristics curves", according to the external static pressure, in DATA BOOK for the usable range of air flow rate.	
5. Be sure to install a valve on the water outlet.	
6. Install a strainer (40 mesh or more) on the pipe next to the valve to remove the foreign matters.	*Above specification data is subject to rounding variation.
7. Please group units that operate on 1 branch.	

PEFY-WP10, 15, 20, 25, 32, 40, 50VMS1-E

Unit: mm

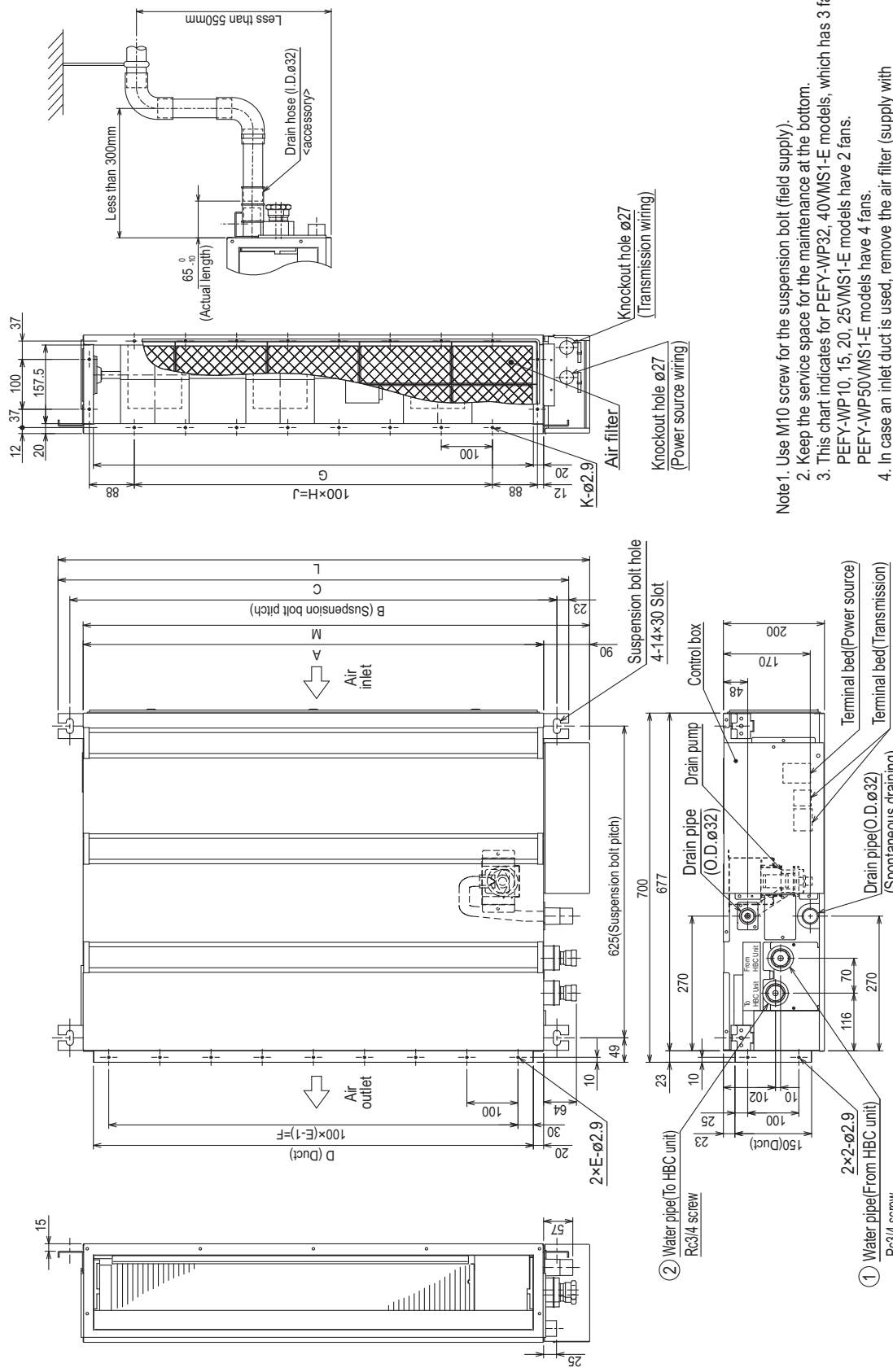

- Note 1. Use M10 screw for the suspension bolt (field supply).
 2. Keep the service space for the maintenance at the bottom.
 3. This chart indicates for PEFY-WP32, 40VMS1-E models, which has 3 fans.
 PEFY-WP10, 15, 20, 25VMS1-E models have 2 fans.
 PEFY-WP50VMS1-E models have 4 fans.
 4. In case an inlet duct is used, remove the air filter (supply with the unit), then install the filter (field supply) at suction side.

Model	A	B	C	D	E	F	G	H	J	K	L	M	① Water pipe (From HBC unit)	② Water pipe (To HBC unit)
PEFY-WP10VMS1-E	700	752	798	660	7	600	660	5	500	16	839	790	Rc3/4 screw	
PEFY-WP15VMS1-E	900	952	998	860	9	800	860	7	700	20	1039	990		
PEFY-WP20VMS1-E	1100	1152	1198	1060	11	1000	1060	9	900	24	1239	1190		
PEFY-WP25VMS1-E														
PEFY-WP32VMS1-E														
PEFY-WP40VMS1-E														

PEFY-WP10, 15, 20, 25, 32, 40, 50VMS1-E

Unit: mm

[Maintenance access space]
 Secure enough access space to allow for the maintenance, inspection, and replacement of the motor, fan, drain pump, heat exchanger, and electric box in one of the following ways.
 Select an installation site for the indoor unit so that its maintenance access space will not be obstructed by beams or other objects.

- (1) When a space of 300mm or more is available below the unit between the unit and the ceiling. (Fig.1)
 - Create access door 1 and 2 (450x450mm each) as shown in Fig.2.
 - (Access door 2 is not required if enough space is available below the unit for a maintenance worker to work in.)
- (2) When a space of less than 300mm is available below the unit between the unit and the ceiling. (At least 20mm of space should be left below the unit as shown in Fig.3.)
 - Create access door 1 diagonally below the electric box and access door 3 below the unit as shown in Fig.4.
 - or
 - Create access door 4 below the electric box and the unit as shown in Fig.5.

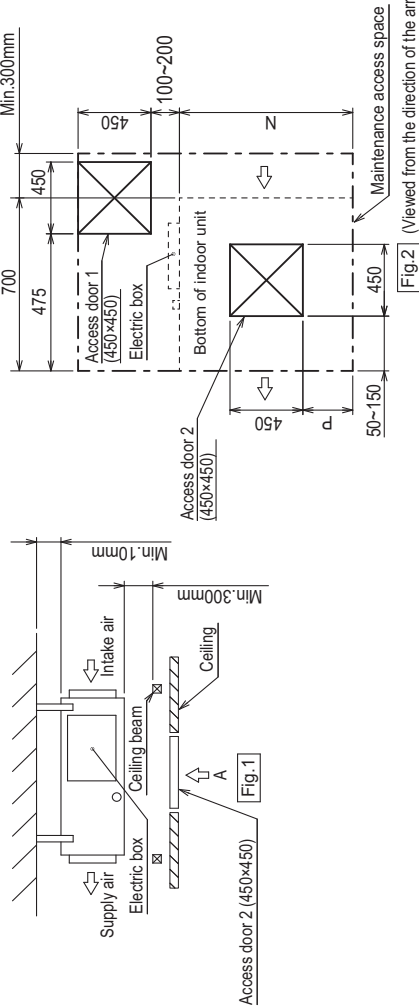

Fig.2 (Viewed from the direction of the arrow A)

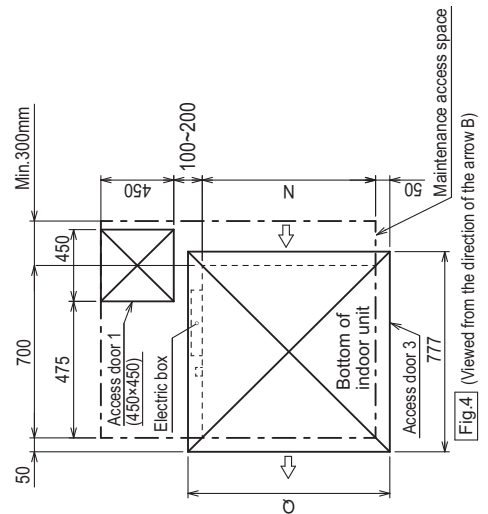

Fig.4 (Viewed from the direction of the arrow B)

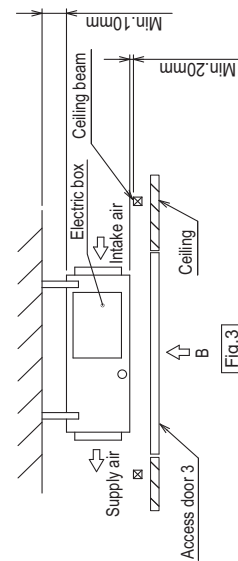

Fig.3

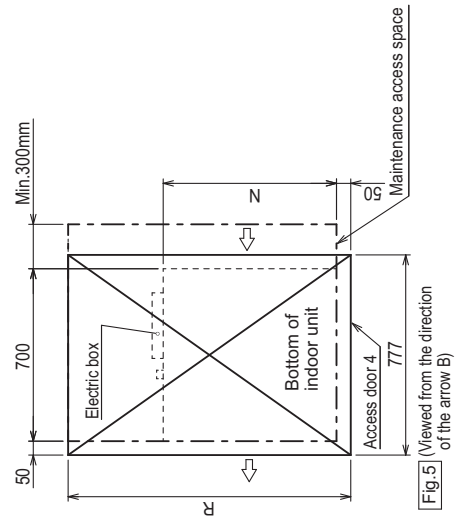
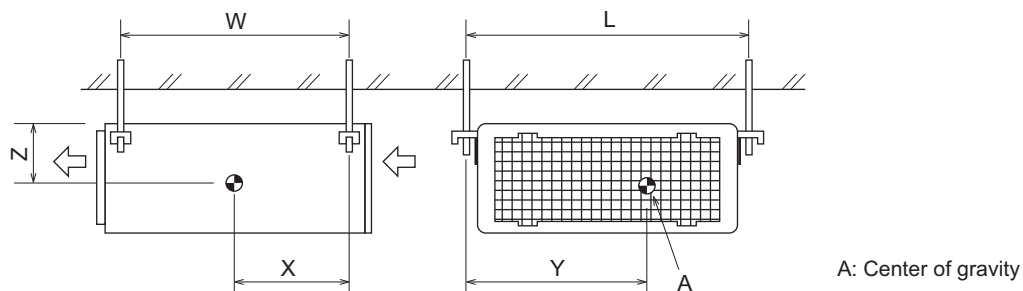

Fig.5 (Viewed from the direction of the arrow B)

Model	N	P	Q	R
PEFY-WP10VMS1-E	700	50~150	800	1300
PEFY-WP15VMS1-E	700	50~150	800	1300
PEFY-WP20VMS1-E	700	50~150	800	1300
PEFY-WP25VMS1-E	900	150~250	1000	1500
PEFY-WP32VMS1-E	900	150~250	1000	1500
PEFY-WP40VMS1-E	1100	250~350	1200	1700
PEFY-WP50VMS1-E	1100	250~350	1200	1700

PEFY-WP10, 15, 20, 25, 32, 40, 50VMS1-E



A: Center of gravity

(mm)[in]

Model name	W	L	X	Y	Z
PEFY-WP10VMS1-E	625 [24-5/8]	752 [29-5/8]	263 [10-3/8]	338 [13-5/16]	105 [4-5/32]
PEFY-WP15VMS1-E	625 [24-5/8]	752 [29-5/8]	263 [10-3/8]	338 [13-5/16]	105 [4-5/32]
PEFY-WP20VMS1-E	625 [24-5/8]	752 [29-5/8]	263 [10-3/8]	338 [13-5/16]	105 [4-5/32]
PEFY-WP25VMS1-E	625 [24-5/8]	752 [29-5/8]	263 [10-3/8]	338 [13-5/16]	105 [4-5/32]
PEFY-WP32VMS1-E	625 [24-5/8]	952 [37-1/2]	280 [11-1/32]	422 [16-5/8]	104 [4-1/8]
PEFY-WP40VMS1-E	625 [24-5/8]	952 [37-1/2]	280 [11-1/32]	422 [16-5/8]	104 [4-1/8]
PEFY-WP50VMS1-E	625 [24-5/8]	1152 [45-3/8]	285 [11-1/4]	511 [20-1/8]	104 [4-1/8]

PEFY-WP10, 15, 20, 25, 32, 40, 50VMS1-E

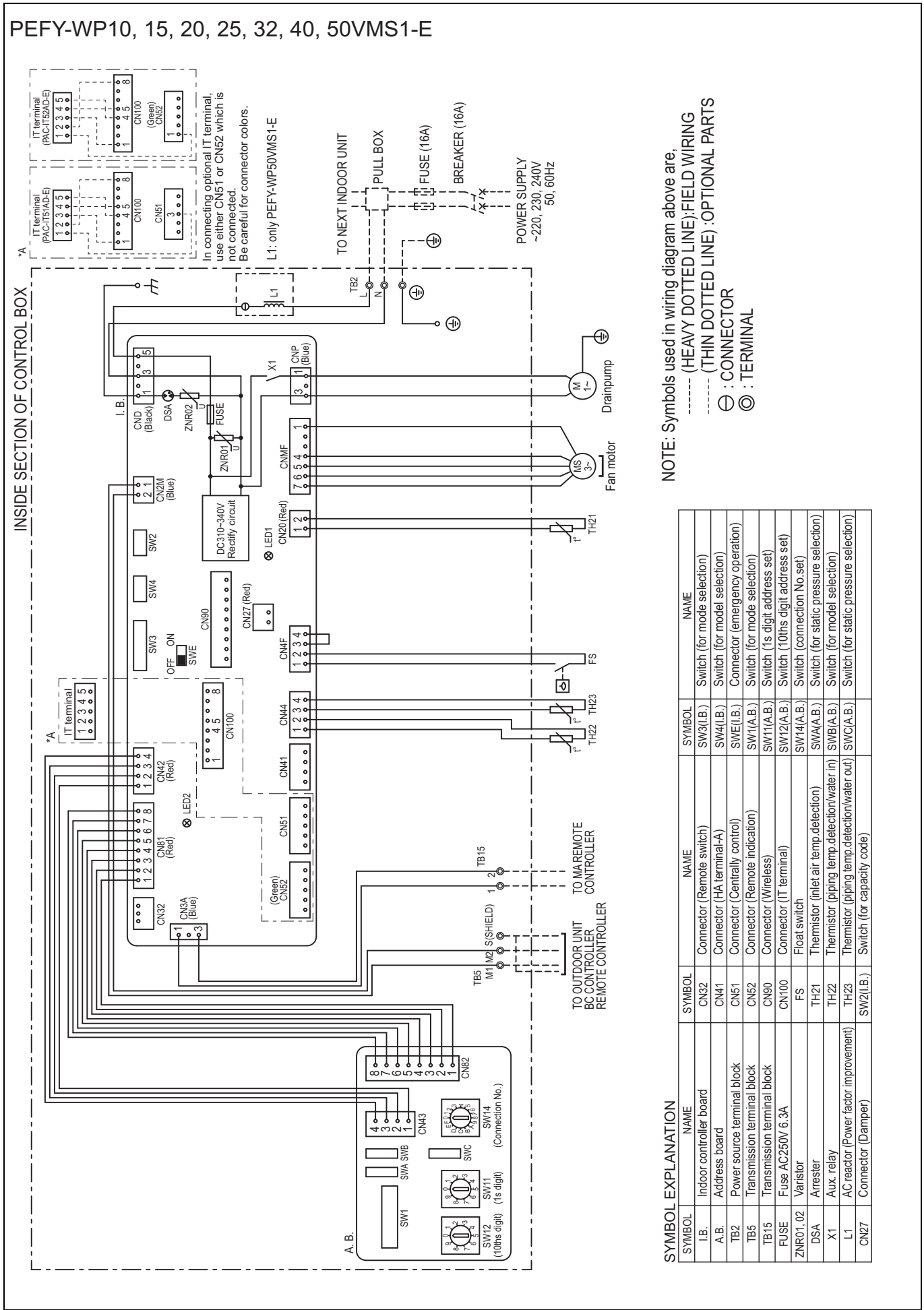

NOTE: Symbols used in wiring diagram above are:
 ----- (HEAVY DOTTED LINE): FIELD WIRING
 - - - - - (THIN DOTTED LINE): OPTIONAL PARTS
 ⊖ : CONNECTOR
 ⊙ : TERMINAL

SYMBOL EXPLANATION

SYMBOL	NAME	SYMBOL	NAME	SYMBOL	NAME
I.B.	Indoor controller board	SW3(I.B.)	Switch (for mode selection)	SW3(I.B.)	Switch (for mode selection)
A.B.	Address board	SW4(I.B.)	Switch (for model selection)	SW4(I.B.)	Switch (for model selection)
TB2	Power source terminal block	SWE(I.B.)	Connector (emergency operation)	SWE(I.B.)	Connector (emergency operation)
TB5	Transmission terminal block	SW1(A.B.)	Switch (for mode selection)	SW1(A.B.)	Switch (for mode selection)
TB15	Transmission terminal block	SW11(A.B.)	Switch (1s digit address set)	SW11(A.B.)	Switch (1s digit address set)
FUSE	Fuse AC250V 6.3A	SW12(A.B.)	Switch (10ths digit address set)	SW12(A.B.)	Switch (10ths digit address set)
ZNR01, 02	Varistor	SW14(A.B.)	Switch (connection No. set)	SW14(A.B.)	Switch (connection No. set)
DSA	Arrester	SWA(A.B.)	Switch (for static pressure selection)	SWA(A.B.)	Switch (for static pressure selection)
X1	Aux. relay	SWB(A.B.)	Switch (for model selection)	SWB(A.B.)	Switch (for model selection)
L1	AC reactor (Power factor improvement)	SWC(A.B.)	Switch (for static pressure selection)	SWC(A.B.)	Switch (for static pressure selection)
CN27	Connector (Damper)	SW2(I.B.)	Switch (for capacity code)	SW2(I.B.)	Switch (for capacity code)

5-1. Sound levels

PEFY-WP-VMS1-E

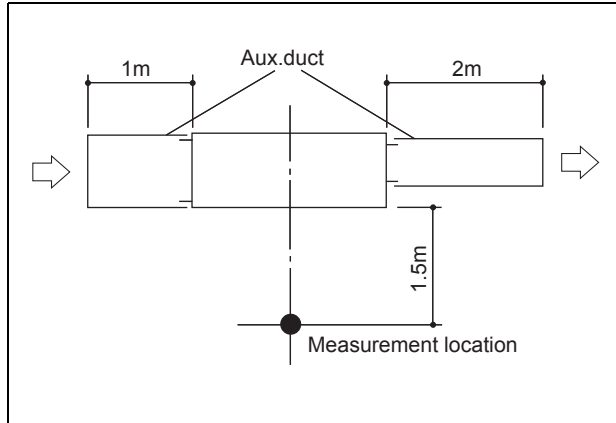

Sound level at anechoic room: Low-Mid-High

		Sound level dB (A)			
		5Pa	15Pa	35Pa	50Pa
PEFY-WP10VMS1-E	220-240V	20 - 21 - 22	20 - 23 - 25	23 - 24 - 25	23 - 25 - 27
PEFY-WP15VMS1-E	220-240V	22 - 24 - 26	22 - 24 - 28	23 - 26 - 29	23 - 27 - 30
PEFY-WP20VMS1-E	220-240V	22 - 25 - 28	23 - 25 - 29	24 - 27 - 30	25 - 28 - 32
PEFY-WP25VMS1-E	220-240V	22 - 25 - 29	23 - 26 - 30	24 - 28 - 31	25 - 29 - 33
PEFY-WP32VMS1-E	220-240V	26 - 28 - 30	28 - 30 - 33	30 - 32 - 35	31 - 33 - 36
PEFY-WP40VMS1-E	220-240V	29 - 31 - 34	30 - 32 - 35	31 - 34 - 37	32 - 34 - 38
PEFY-WP50VMS1-E	220-240V	29 - 32 - 35	30 - 33 - 36	31 - 35 - 39	32 - 36 - 40

* Measured in anechoic room.

PEFY-WP-VMS1-E

5-2. NC curves

PEFY-WP-VMS1-E

PEFY-WP10VMS1-E
 External Static Pressure: 5Pa [0.02in.WG]
 Power Source: 220,230,240V, 50/60Hz

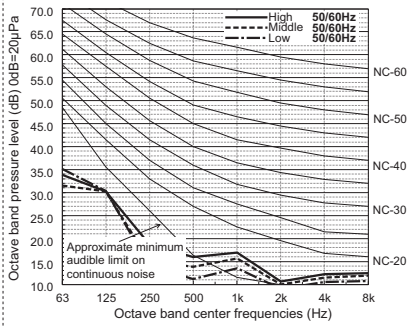

PEFY-WP10VMS1-E
 External Static Pressure: 15Pa [0.06in.WG]
 Power Source: 220,230,240V, 50/60Hz

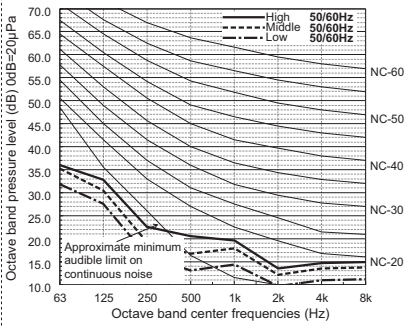

PEFY-WP10VMS1-E
 External Static Pressure: 35Pa [0.14in.WG]
 Power Source: 220,230,240V, 50/60Hz

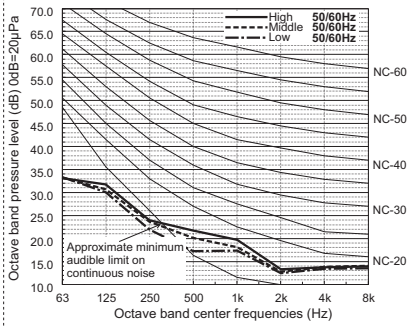

PEFY-WP10VMS1-E
 External Static Pressure: 50Pa [0.20in.WG]
 Power Source: 220,230,240V, 50/60Hz

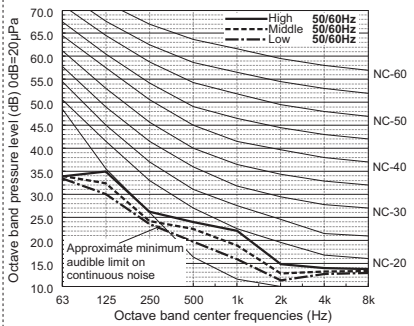

PEFY-WP15VMS1-E
 External static pressure : 5Pa
 Power source : 220,230,240V, 50/60Hz

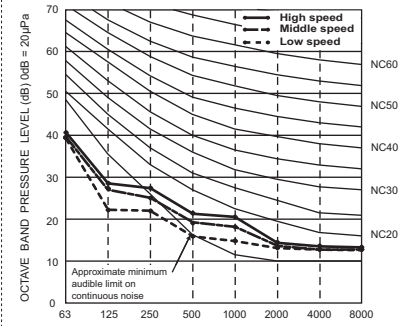

PEFY-WP15VMS1-E
 External static pressure : 15Pa
 Power source : 220,230,240V, 50/60Hz

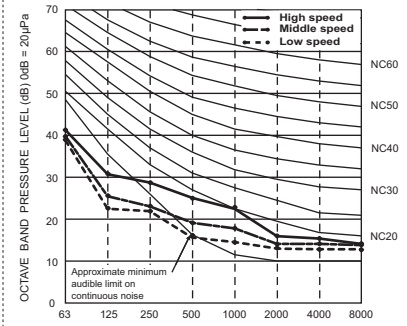

PEFY-WP15VMS1-E
 External static pressure : 35Pa
 Power source : 220,230,240V, 50/60Hz

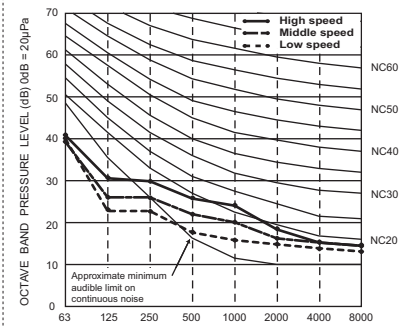

PEFY-WP15VMS1-E
 External static pressure : 50Pa
 Power source : 220,230,240V, 50/60Hz

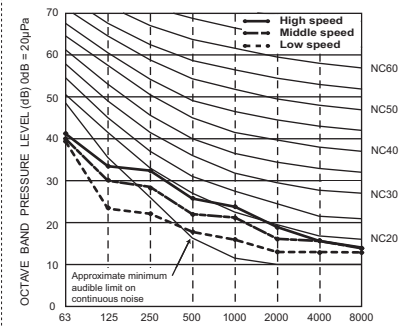

PEFY-WP20VMS1-E
 External static pressure : 5Pa
 Power source : 220,230,240V, 50/60Hz

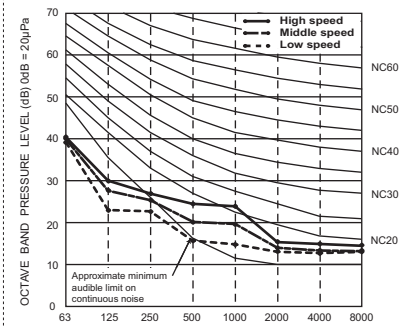

PEFY-WP20VMS1-E
 External static pressure : 15Pa
 Power source : 220,230,240V, 50/60Hz

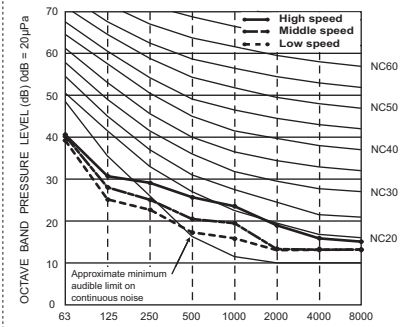

PEFY-WP20VMS1-E
 External static pressure : 35Pa
 Power source : 220,230,240V, 50/60Hz

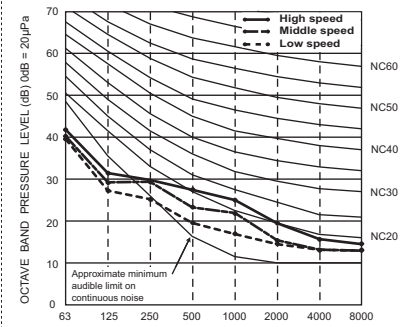

PEFY-WP20VMS1-E
 External static pressure : 50Pa
 Power source : 220,230,240V, 50/60Hz

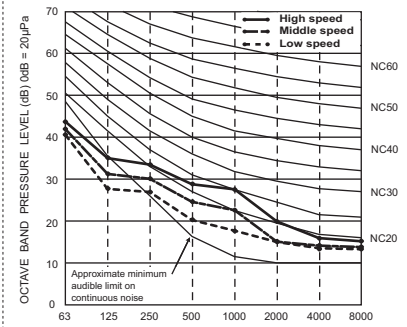

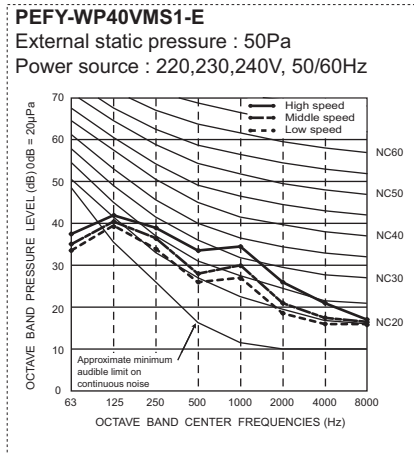
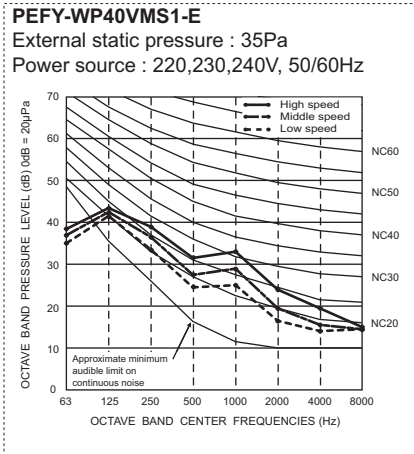
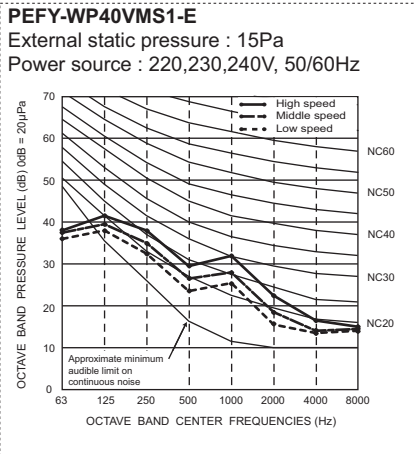
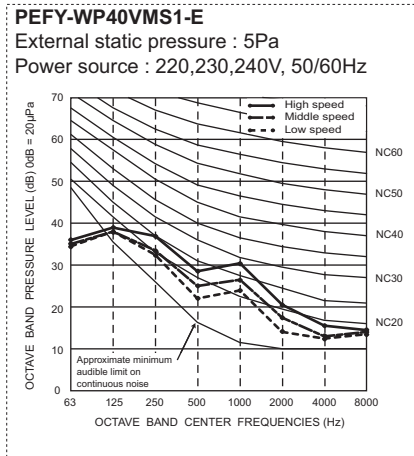
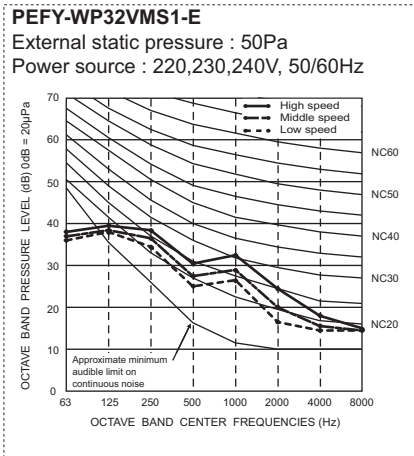
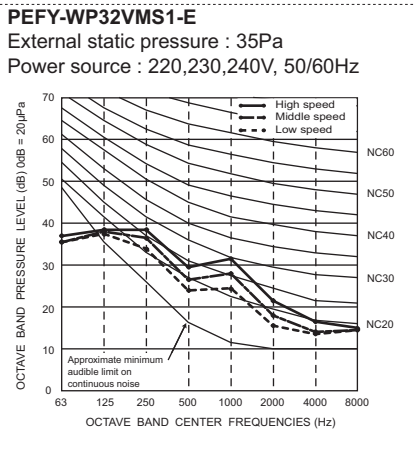
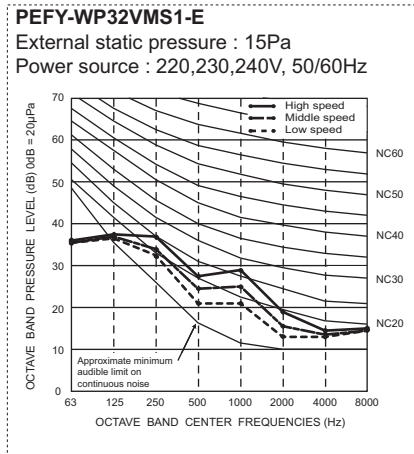
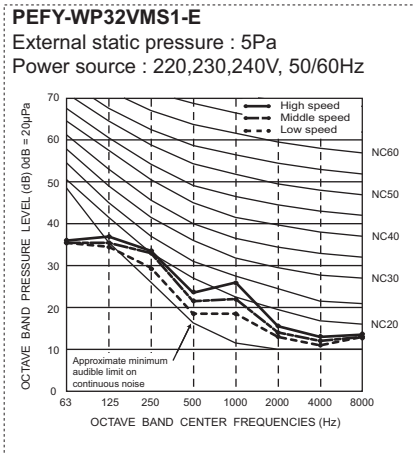
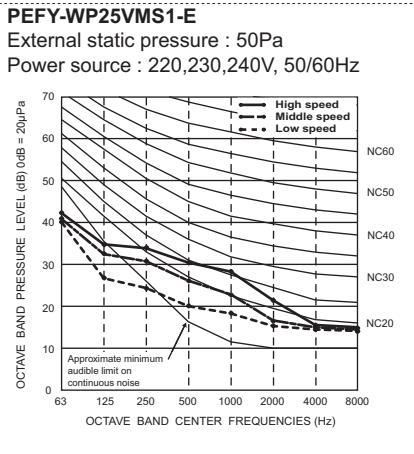
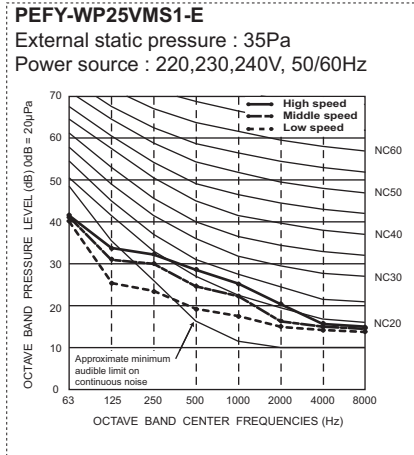
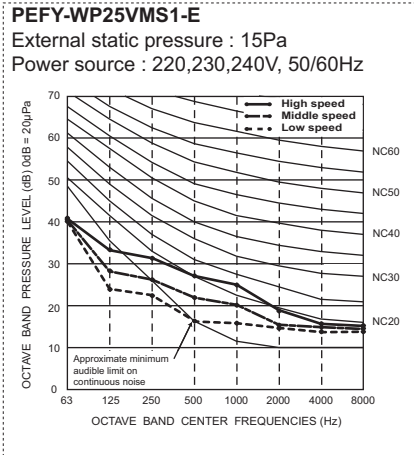
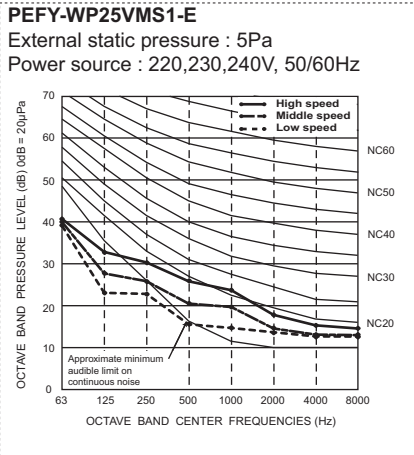

PEFY-WP50VMS1-E
 External static pressure : 5Pa
 Power source : 220,230,240V, 50/60Hz

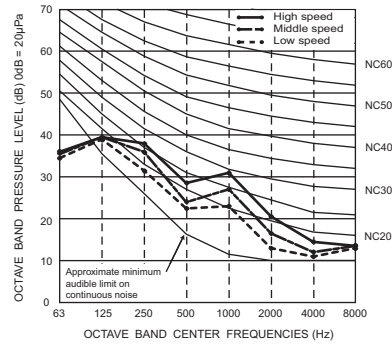

PEFY-WP50VMS1-E
 External static pressure : 15Pa
 Power source : 220,230,240V, 50/60Hz

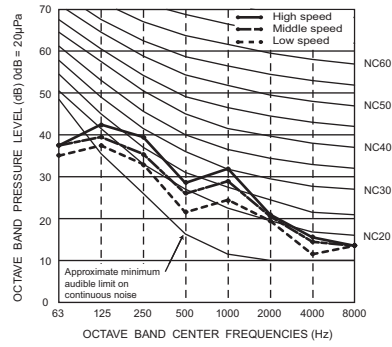

PEFY-WP50VMS1-E
 External static pressure : 35Pa
 Power source : 220,230,240V, 50/60Hz

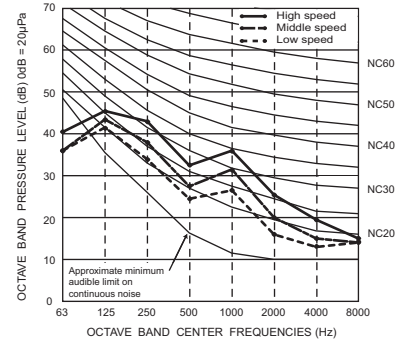

PEFY-WP50VMS1-E
 External static pressure : 50Pa
 Power source : 220,230,240V, 50/60Hz

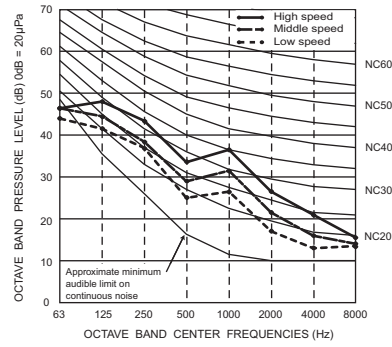

PEFY-WP-VMS1-E

6. FAN CHARACTERISTICS CURVES

Ceiling concealed (Low static pressure type)

PEFY-WP-VMS1-E

PEFY-WP10VMS1-E

External static pressure : 5Pa

Power source : 220,230,240V, 50/60Hz

Suction : Back inlet

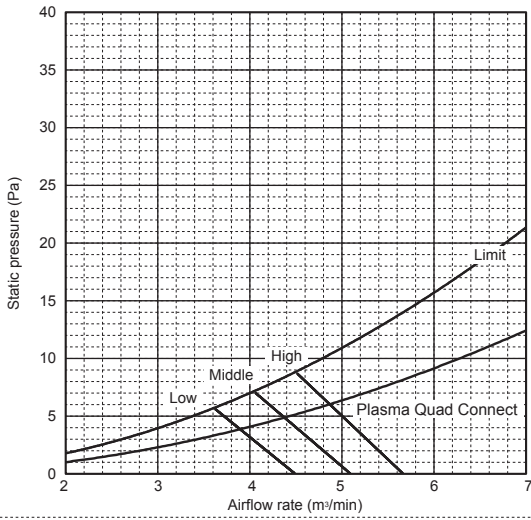

PEFY-WP10VMS1-E

External static pressure : 15Pa

Power source : 220,230,240V, 50/60Hz

Suction : Back inlet

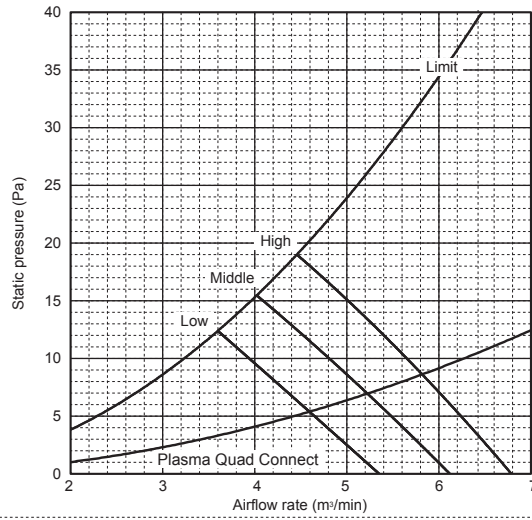

PEFY-WP10VMS1-E

External static pressure : 35Pa

Power source : 220,230,240V, 50/60Hz

Suction : Back inlet

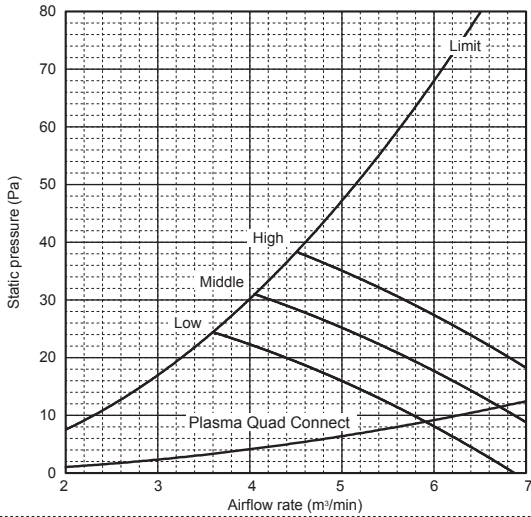

PEFY-WP10VMS1-E

External static pressure : 50Pa

Power source : 220,230,240V, 50/60Hz

Suction : Back inlet

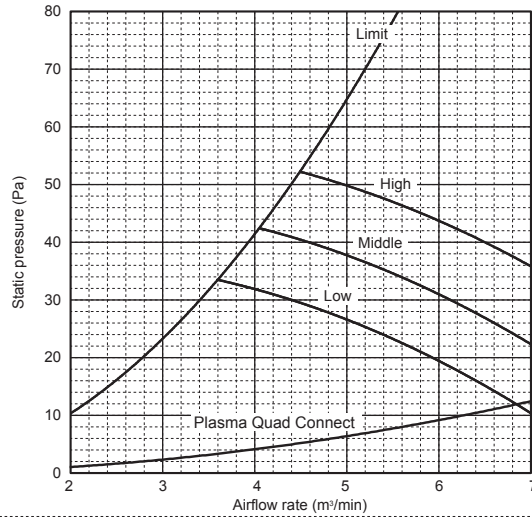

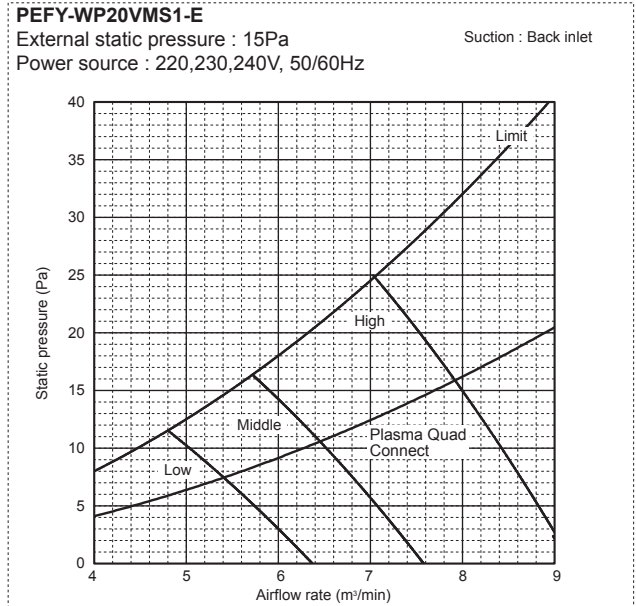
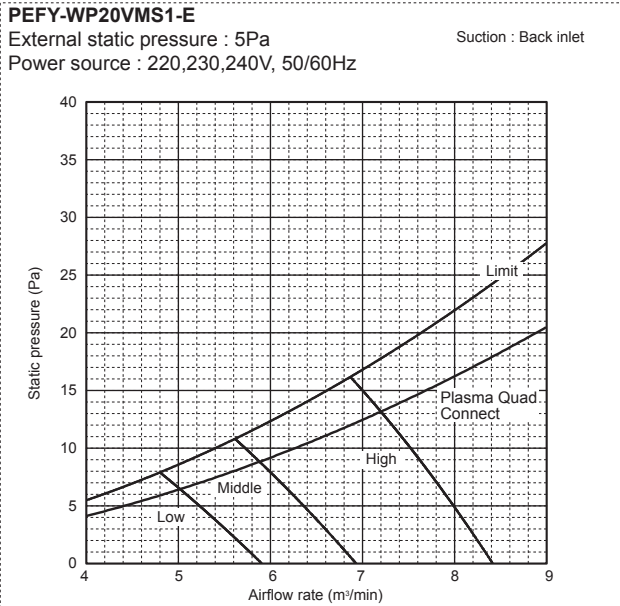
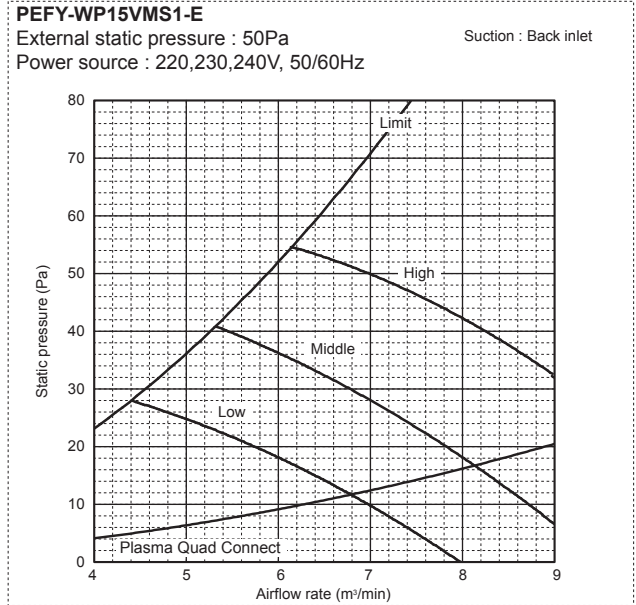
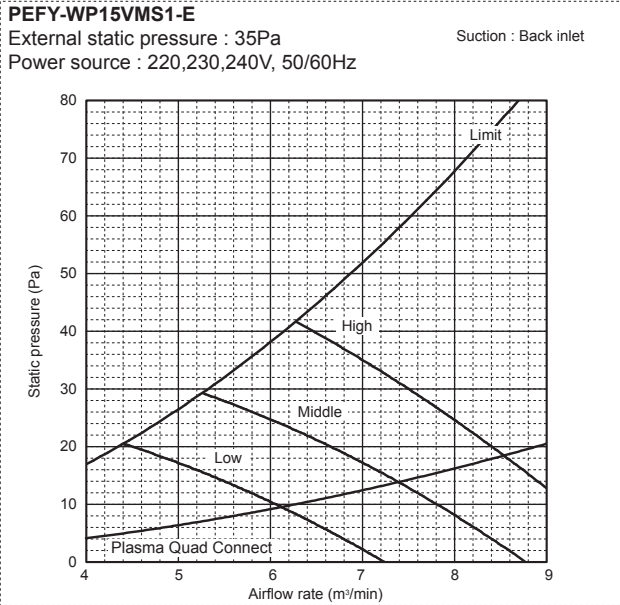
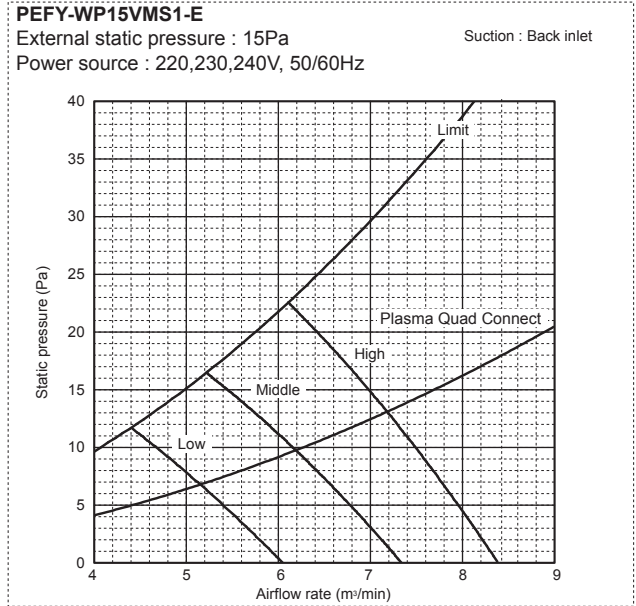
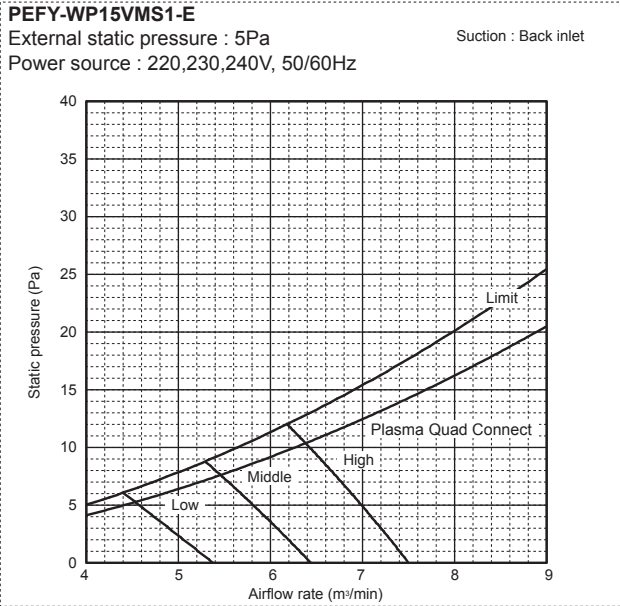

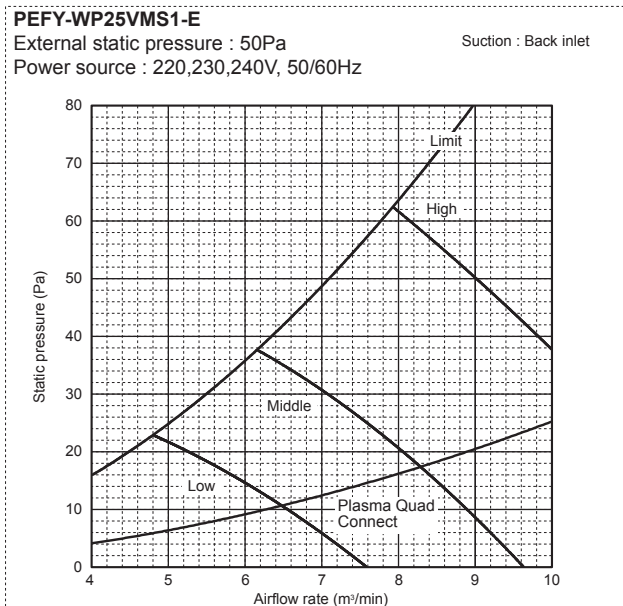
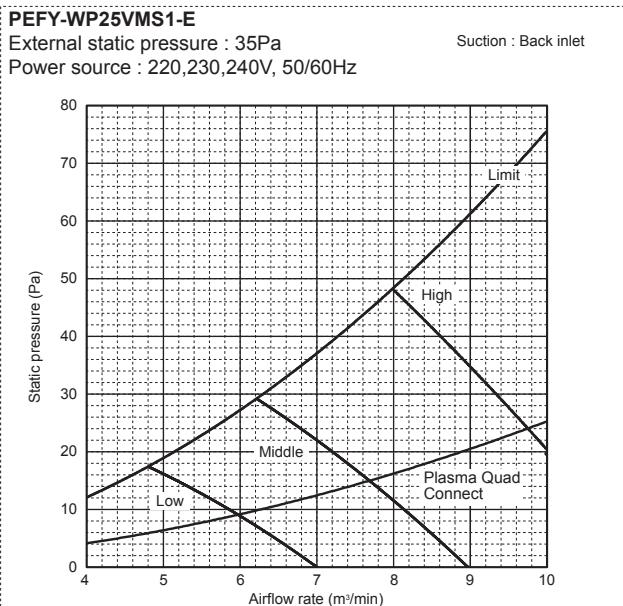
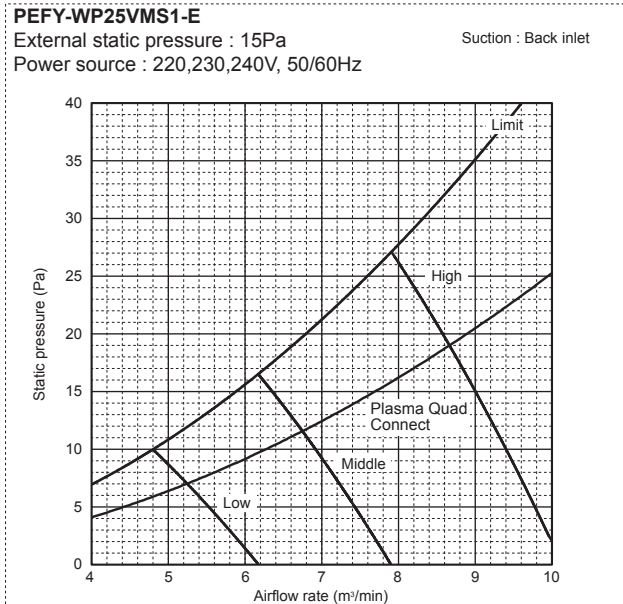
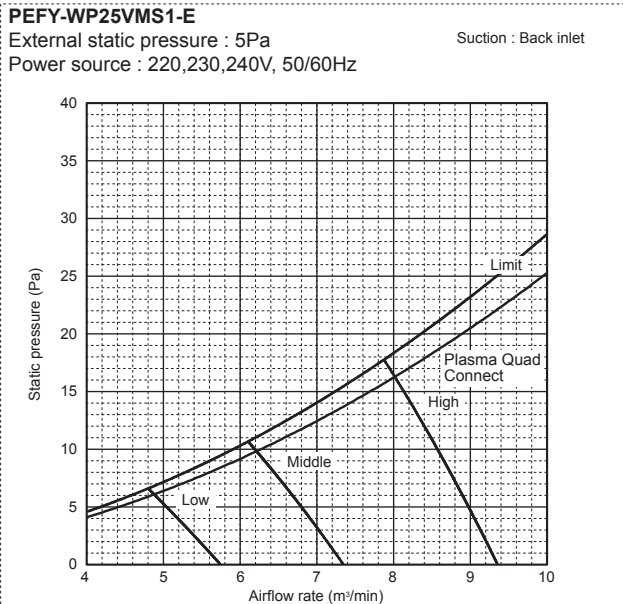
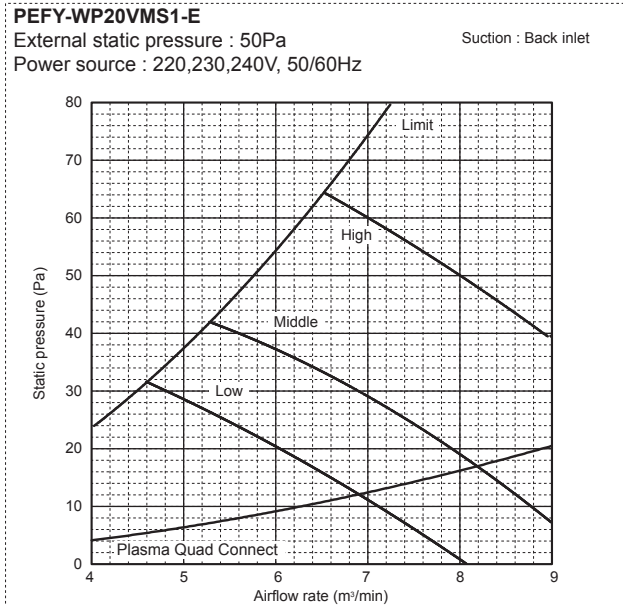
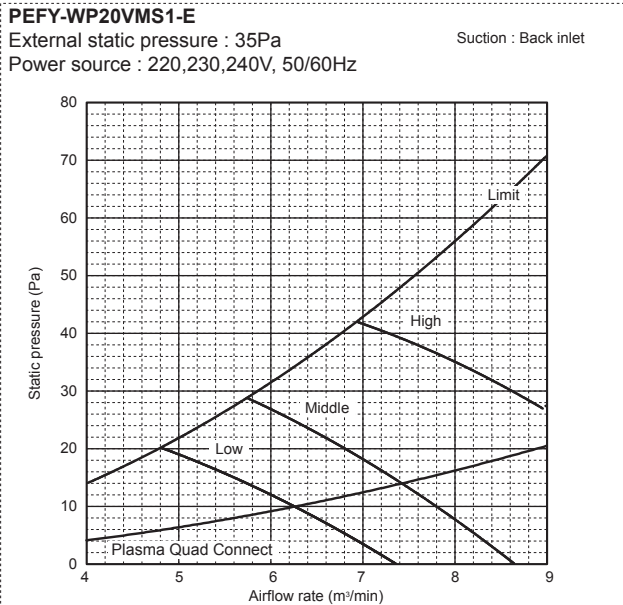

PEFY-WP32VMS1-E
 External static pressure : 5Pa
 Power source : 220,230,240V, 50/60Hz
 Suction : Back inlet

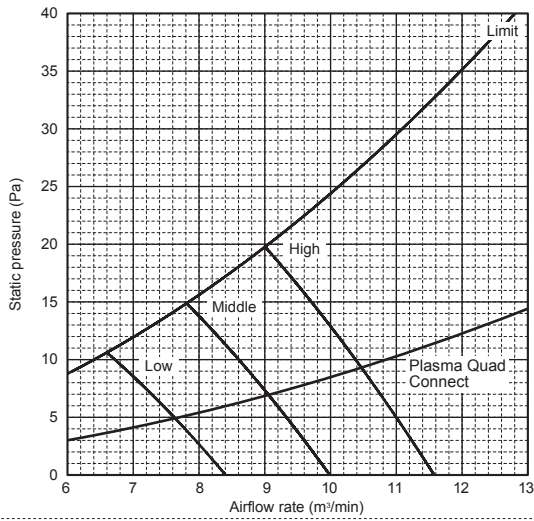

PEFY-WP32VMS1-E
 External static pressure : 15Pa
 Power source : 220,230,240V, 50/60Hz
 Suction : Back inlet

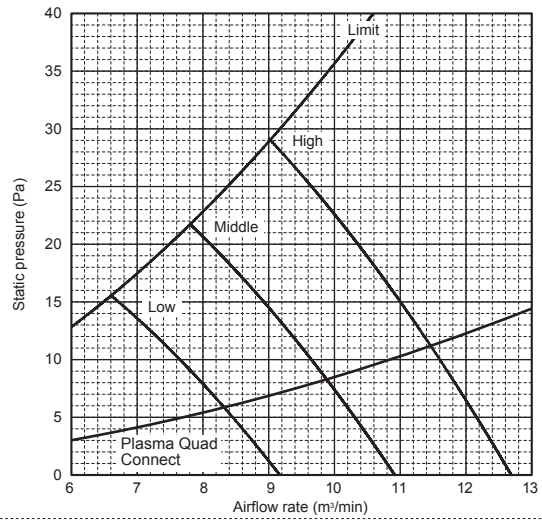

PEFY-WP32VMS1-E
 External static pressure : 35Pa
 Power source : 220,230,240V, 50/60Hz
 Suction : Back inlet

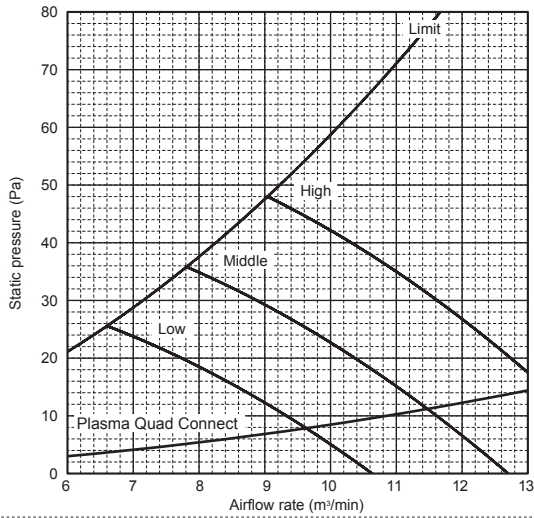

PEFY-WP32VMS1-E
 External static pressure : 50Pa
 Power source : 220,230,240V, 50/60Hz
 Suction : Back inlet

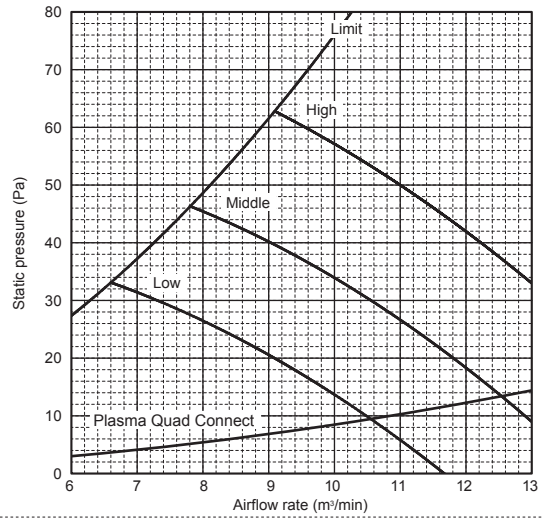

PEFY-WP40VMS1-E
 External static pressure : 5Pa
 Power source : 220,230,240V, 50/60Hz
 Suction : Back inlet

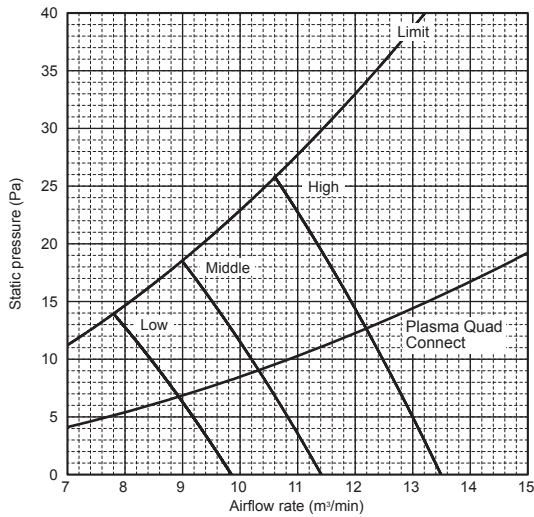

PEFY-WP40VMS1-E
 External static pressure : 15Pa
 Power source : 220,230,240V, 50/60Hz
 Suction : Back inlet

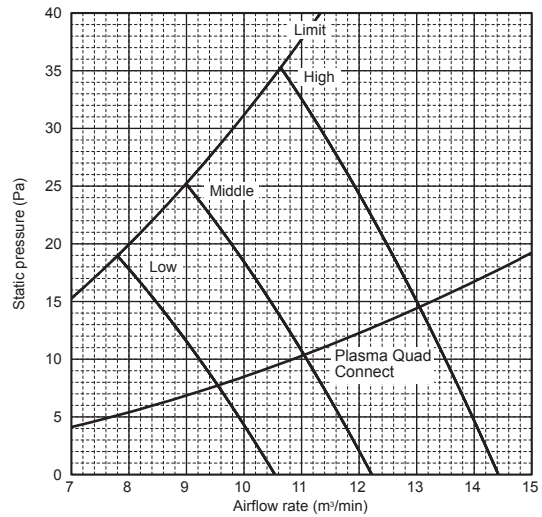

6. FAN CHARACTERISTICS CURVES

Ceiling concealed (Low static pressure type)

PEFY-WP-VMS1-E

PEFY-WP40VMS1-E
 External static pressure : 35Pa
 Power source : 220,230,240V, 50/60Hz
 Suction : Back inlet

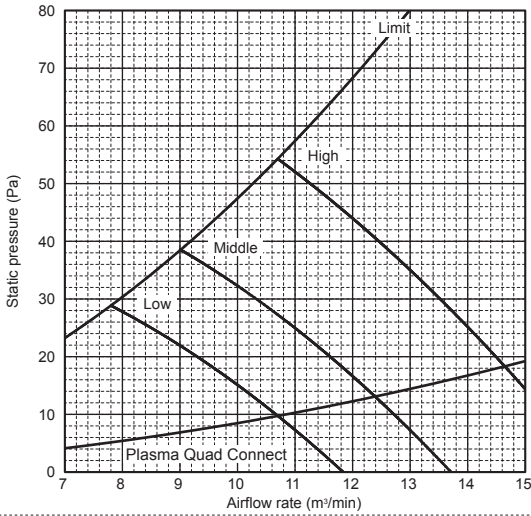

PEFY-WP40VMS1-E
 External static pressure : 50Pa
 Power source : 220,230,240V, 50/60Hz
 Suction : Back inlet

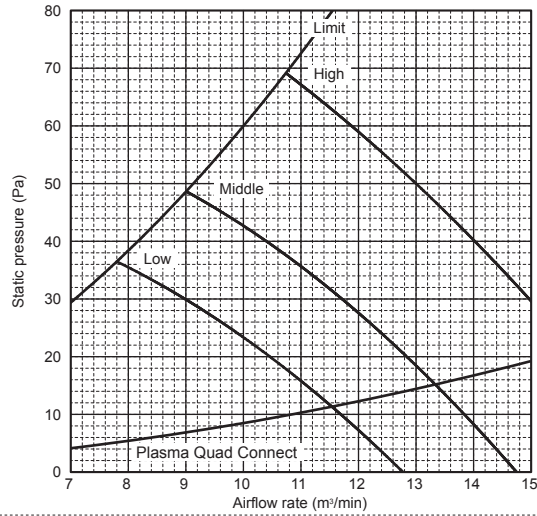

PEFY-WP50VMS1-E
 External static pressure : 5Pa
 Power source : 220,230,240V, 50/60Hz
 Suction : Back inlet

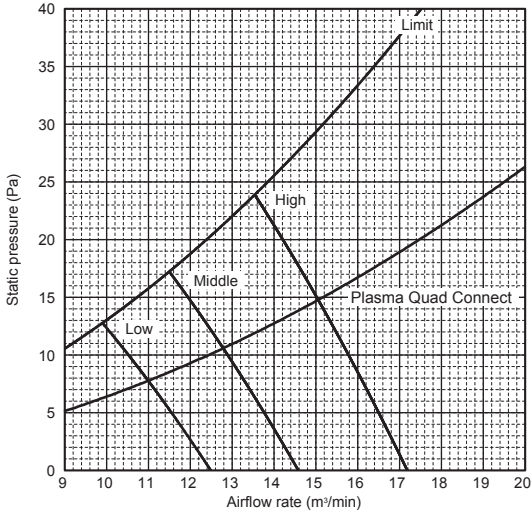

PEFY-WP50VMS1-E
 External static pressure : 15Pa
 Power source : 220,230,240V, 50/60Hz
 Suction : Back inlet

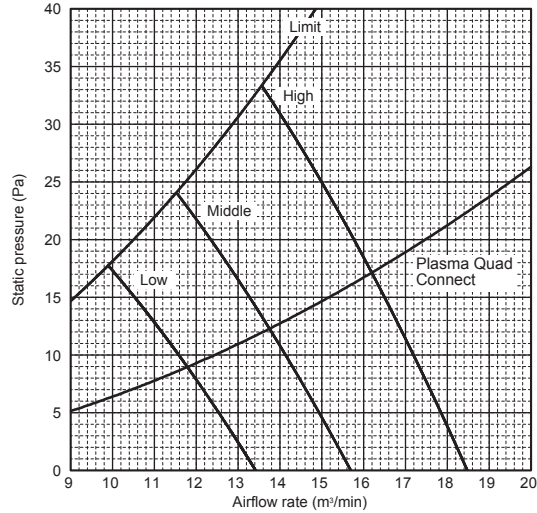

PEFY-WP50VMS1-E
 External static pressure : 35Pa
 Power source : 220,230,240V, 50/60Hz
 Suction : Back inlet

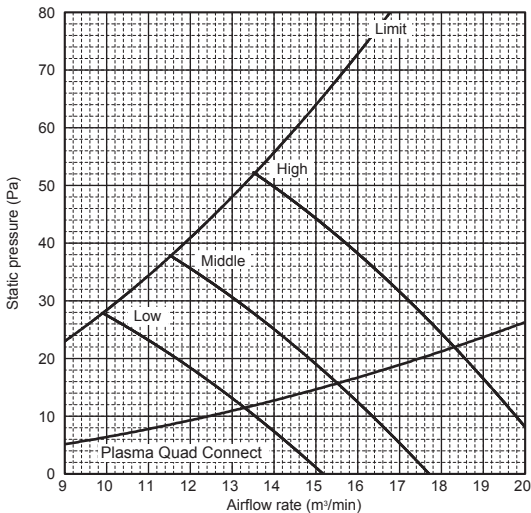

PEFY-WP50VMS1-E
 External static pressure : 50Pa
 Power source : 220,230,240V, 50/60Hz
 Suction : Back inlet

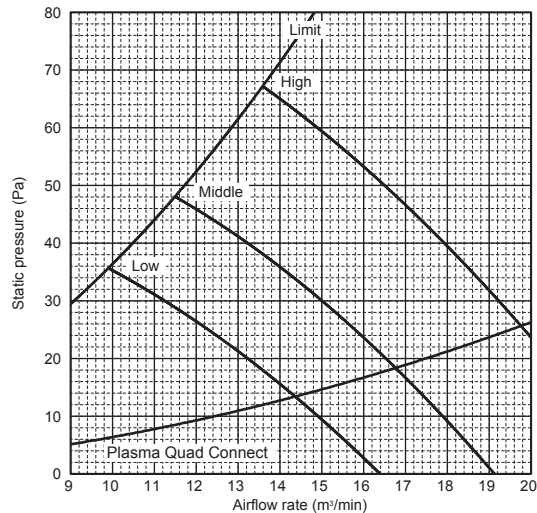

7. ELECTRICAL CHARACTERISTICS

Ceiling concealed (Low static pressure type)

Symbols: MCA: Max.Circuit Amps (=1.25xFLA) FLA: Full Load Amps

IFM: Indoor Fan Motor Output: Fan motor rated output

PEFY-WP-VMS1-E	Power supply			IFM	
	Volts/Hz	Range +-10%	MCA(A)	Output (kW)	FLA(A)
PEFY-WP10VMS1-E	220-240V/50Hz 220-240V/60Hz	Max.: 264V Min.: 198V	0.40/0.40	0.096	0.32/0.32
PEFY-WP15VMS1-E			0.63/0.63	0.096	0.50/0.50
PEFY-WP20VMS1-E			0.70/0.70	0.096	0.56/0.56
PEFY-WP25VMS1-E			0.75/0.75	0.096	0.60/0.60
PEFY-WP32VMS1-E			0.83/0.82	0.096	0.66/0.65
PEFY-WP40VMS1-E			1.02/1.00	0.096	0.81/0.80
PEFY-WP50VMS1-E			1.08/1.07	0.096	0.86/0.85

PEFY-WP-VMS1-E

8-1. Optional parts line up for the Indoor unit

	Control box replace kit	Plasma Quad Connect	PQ attachment
PEFY-WP10, 15, 20, 25, 32, 40, 50VMS1-E	PAC-KE70HS-E	MAC-100FT-E	PAC-HA11PAR





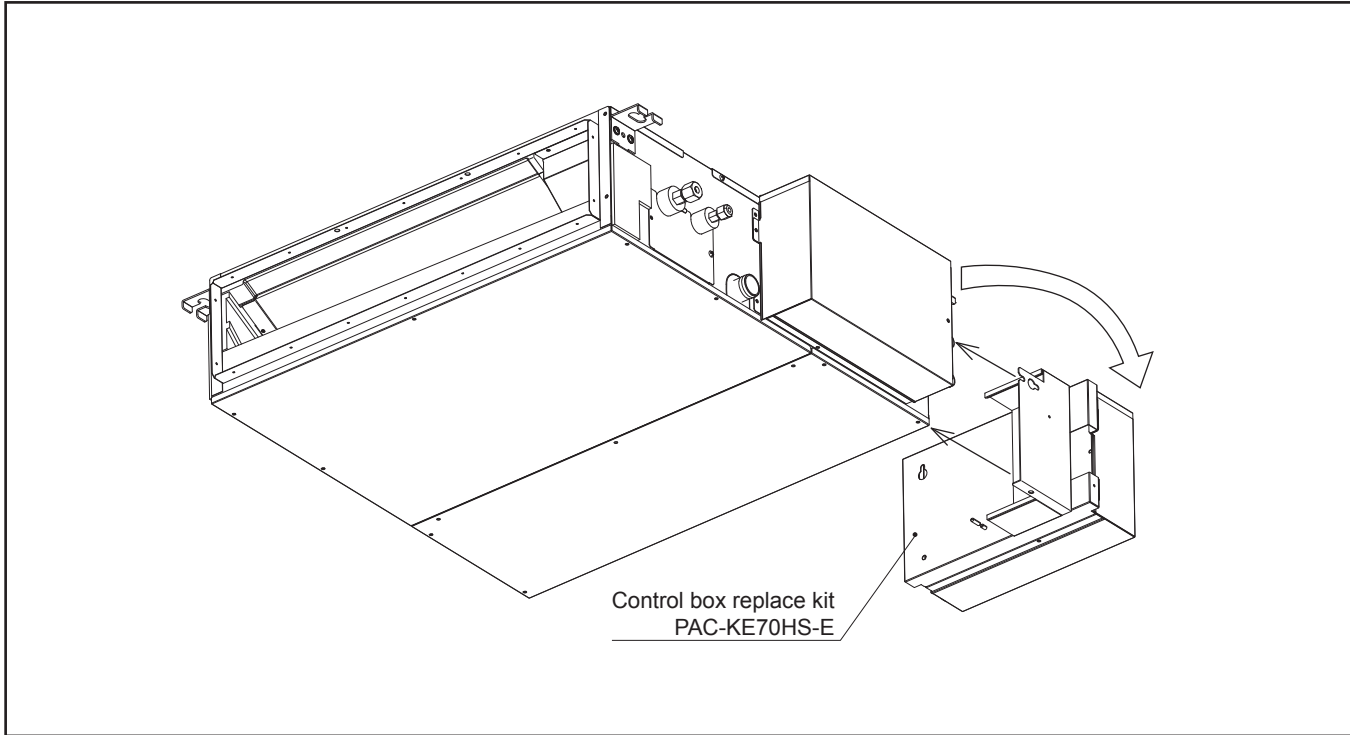





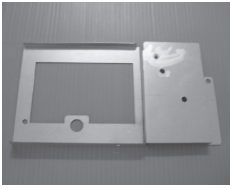
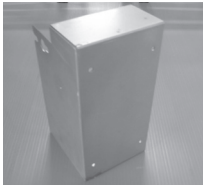
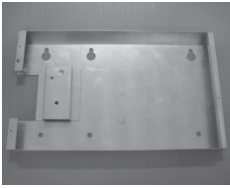
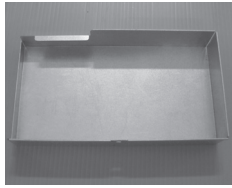
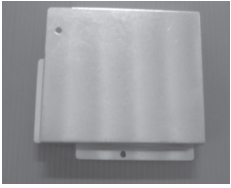



PEFY-WP-VMS1-E

PEFY-WP-VMS1-E

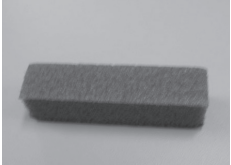

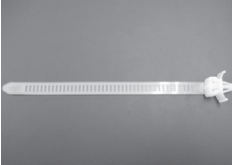
8-2. Control box replace kit

PAC-KE70HS-E

Parts	① PLATE A	② PLATE B	③ PLATE C	④ COVER A
Q'ty	1	1	1	1
Shape				
Parts	⑤ COVER B	⑥ LEAD WIRE MOTOR	⑦ LEAD WIRE LEV	⑧ LEAD WIRE THM A
Q'ty	1	1	1	1
Shape		 White 7-pin connector	 White 6-pin connector	 White 4-pin connector
Parts	⑨ LEAD WIRE THM B	⑩ LEAD WIRE EARTH	⑪ LEAD WIRE PUMP	⑫ LEAD WIRE FS
Q'ty	1	1	1	1
Shape	 Red 2-pin connector	 Ring terminal on both ends	 Blue 3-pin connector	 White 4-pin connector
Parts	⑬ INSULATOR	⑭ Connecting terminals	⑮ BAND	⑯ CLAMP
Q'ty	3	4	6	4
Shape				
Parts	⑰ SCREW 1	⑱ SCREW 2	⑲ SCREW 3	⑳ FERRITE CORE
Q'ty	2	4	5	1
Shape	 4X10	 4X10 with a washer	 5X10 with a washer	







When installing the control box replace kit on the air inlet on the unit, ⑫ LEAD WIRE FS is not used.

8-3. Plasma Quad Connect

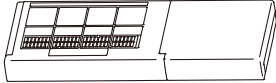
Static pressure loss is referred to 6 "FAN CHARACTERISTICS CURVES". Plasma Quad Connect (MAC-100FT-E) should be used together with PQ attachment (PAC-HA11PAR).

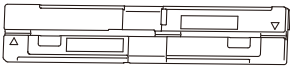

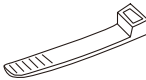

* Attaching the Plasma Quad Connect increases the pressure loss. In a certain capacity range where the airflow may not reach the rated airflow level with the factory default external static pressure setting, adjust the external static pressure setting as necessary. For the adjustment procedure, see the Installation Manual for the indoor unit.

Plasma Quad Connect (MAC-100FT-E)

Item	Plasma Quad Connect (with connecting cable)	Installation plate	Fixing screw for Plasma Quad Connect and Installation plate 4 × 25 mm
Quantity	1	1	5
Shape			
Item	Spacer Note: The spacer is used as packaging material.	Mounting cord clamp	Cable tie
Quantity	1	1	1
Shape			
Item	Screw for Mounting cord clamp 4 × 16 (Use when joining room air conditioner parts)		
Quantity	1		
Shape			

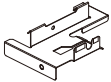
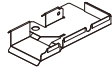
Detailed installation information should be referred to its Installation Manual.

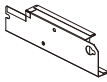
PQ attachment (PAC-HA11PAR)

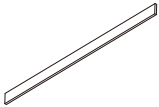
Item	PLATE 1	PLATE 2	PLATE 3	PLATE 4	Screw (4 × 10)	Screw (5 × 10)	RUBBER PLATE
Quantity	1	1	1	1	3	2	2
Shape							

Detailed installation information should be referred to its Installation Manual.

PEFY-WP10, 15, 20, 25, 32, 40, 50VMS1-E
with PQ attachment and Plasma Quad Connect

Unit: mm

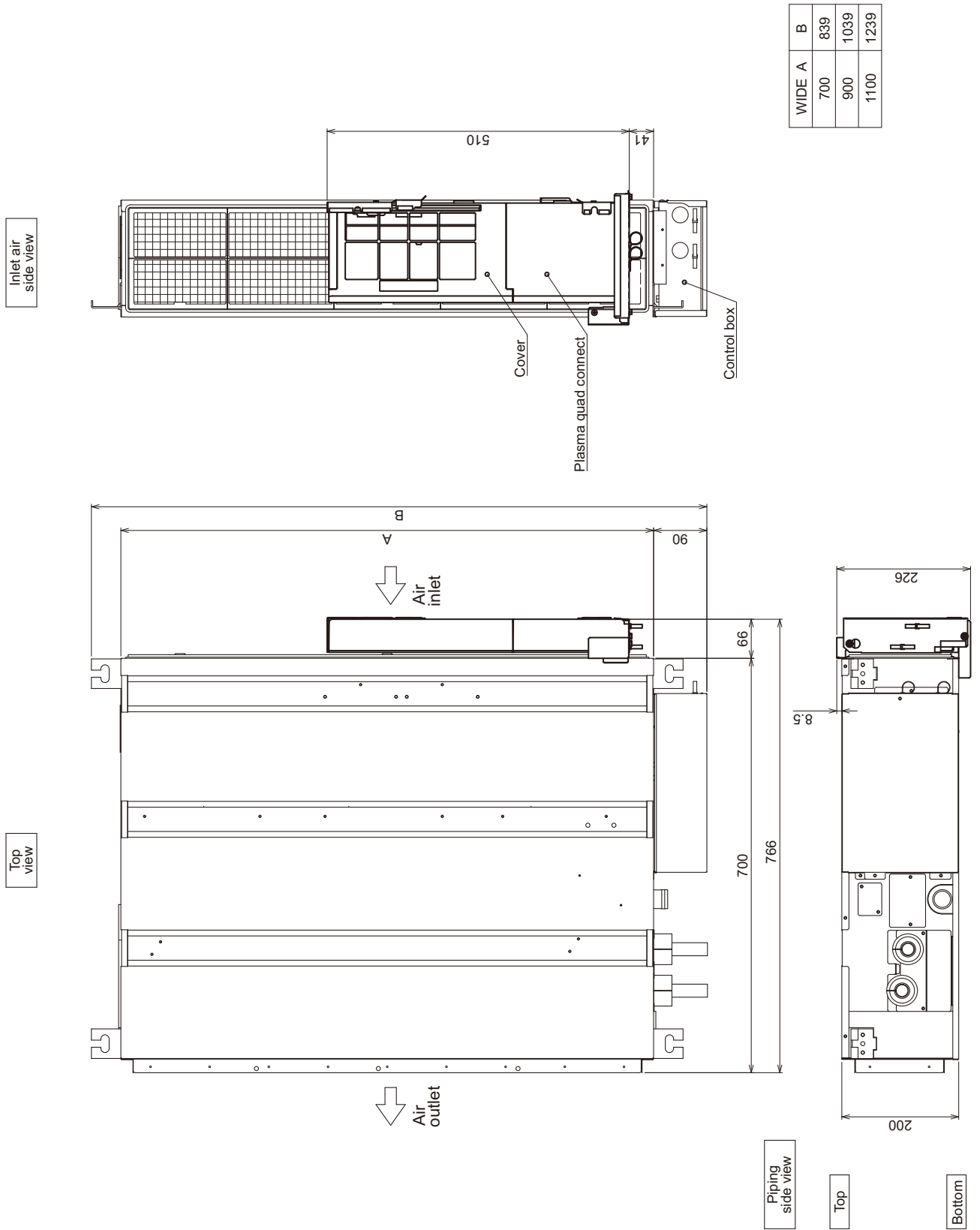

WIDE A	B
700	839
900	1039
1100	1239

Model	WIDE A	B
PEFY-WP10,15,20,25VMS1-E	700	839
PEFY-WP32,40VMS1-E	900	1039
PEFY-WP50VMS1-E	1100	1239

The drawing above is a sample image of the optional parts being installed on a unit.

PEFY-WP10,15, 20, 25, 32, 40, 50VMS1-E
with PQ attachment and Plasma Quad Connect

Unit: mm

[Maintenance access space]
Secure enough access space to allow for the maintenance, inspection, and replacement of the motor, fan, heat exchanger, and control box in one of the following ways.
Select an installation site for the indoor unit so that its maintenance access space will not be obstructed by beams or other objects.
(1) When a space of 300mm or more is available below the unit between the unit and the ceiling. (Fig.1)
• Create access door 1 and 2 (450×450mm each) as shown in Fig.2.
(2) When a space of less than 300mm is available below the unit between the unit and the ceiling.
(At least 20mm of space should be left below the unit as shown in Fig.3.)
• Create access door 1 diagonally below the control box and access door 3 below the unit as shown in Fig.4.
or
• Create access door 4 below the control box and the unit as shown in Fig.5.
(3) For maintenance if there is more than 170mm from the top surface, the cover can be pulled out without removing the PQ attachment. (Fig.1, Fig.3)

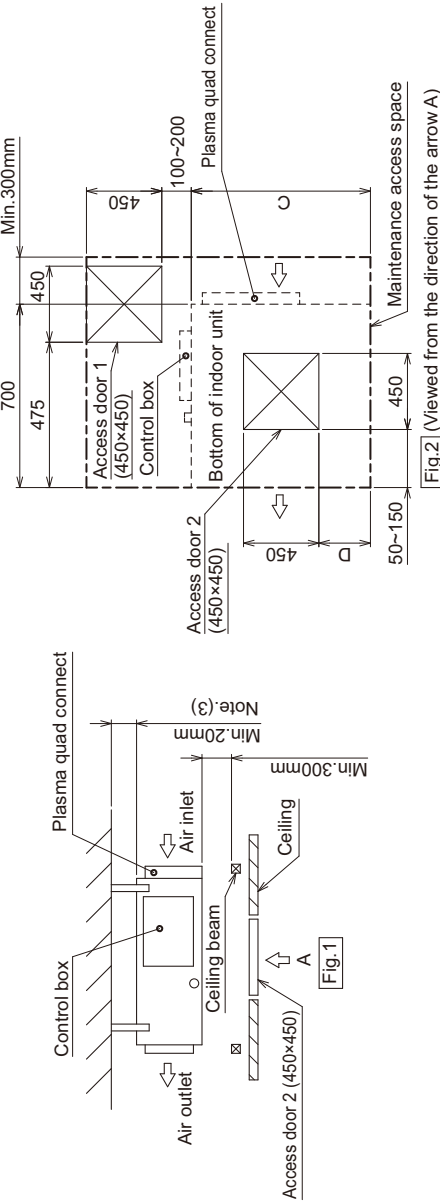

Fig.2 (Viewed from the direction of the arrow A)

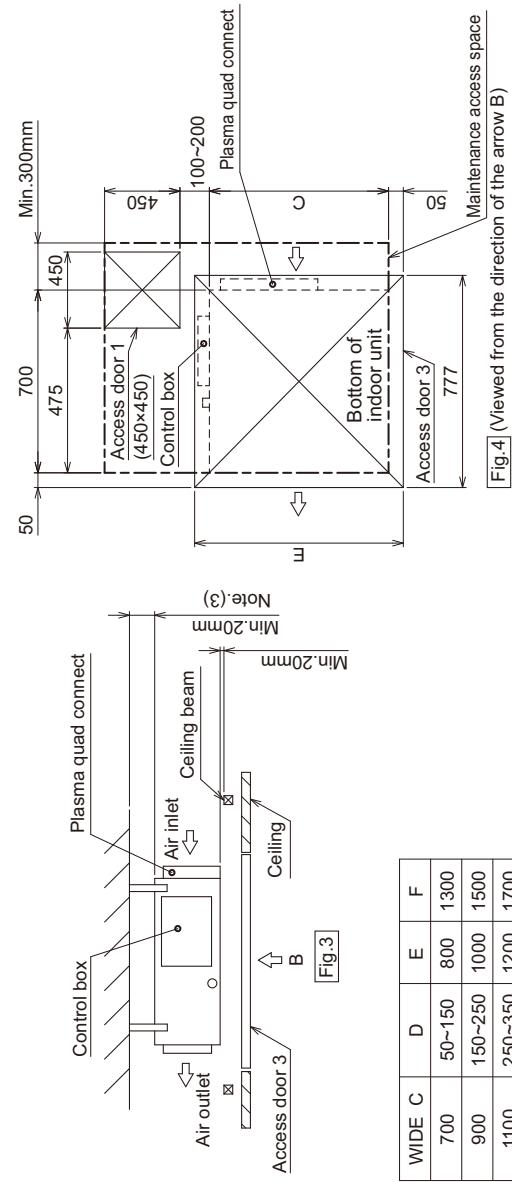

Fig.4 (Viewed from the direction of the arrow B)

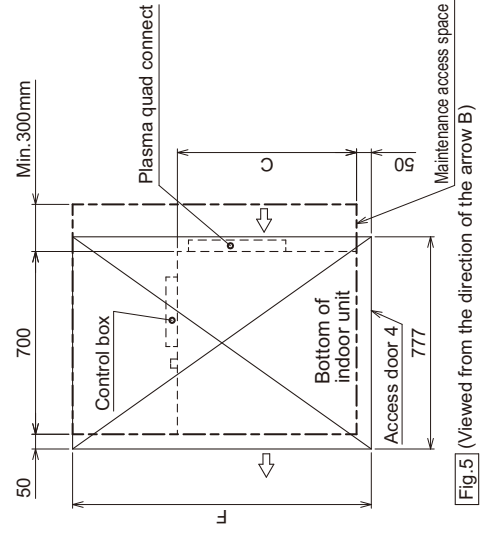

Fig.5 (Viewed from the direction of the arrow B)

WIDE C	D	E	F
700	50~150	800	1300
900	150~250	1000	1500
1100	250~350	1200	1700

Model	WIDE C	D	E	F
PEFY-WP10,15,20,25VMS1-E	700	50~150	800	1300
PEFY-WP32,40VMS1-E	900	150~250	1000	1500
PEFY-WP50VMS1-E	1100	250~350	1200	1700

The drawing above is a sample image of the optional parts being installed on a unit.

⚠ Warning

- Do not use refrigerant other than the type indicated in the manuals provided with the unit and on the nameplate.
 - Doing so may cause the unit or pipes to burst, or result in explosion or fire during use, repair, or at the time of disposal of the unit.
 - It may also be in violation of applicable laws.
 - MITSUBISHI ELECTRIC CORPORATION cannot be held responsible for malfunctions or accidents resulting from the use of the wrong type of refrigerant.
- Our air conditioning equipment and heat pumps contain a fluorinated greenhouse gas, R410A/R32.

MITSUBISHI ELECTRIC CORPORATION

www.MitsubishiElectric.com