

AIR CONDITIONING SYSTEMS

CITY MULTI



DATA BOOK

MODEL

PEFY-M-VMA(L)-A1

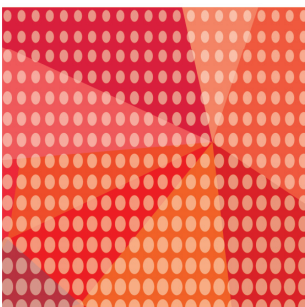

PEFY-M-VMA(L)-A1

1. SPECIFICATIONS	2
2. EXTERNAL DIMENSIONS	8
3. CENTER OF GRAVITY	16
4. ELECTRICAL WIRING DIAGRAMS	17
5. SOUND LEVELS	18
5-1. Sound levels	18
5-2. NC curves	19
6. FAN CHARACTERISTICS CURVES.....	24
7. CAPACITY TABLES	33
7-1. Correction by fan speed.....	33
8. ELECTRICAL CHARACTERISTICS.....	34
9. OPTIONAL PARTS.....	35
9-1. Optional parts line up for the Indoor unit.....	35
9-2. Filter box	35
9-3. Plasma Quad Connect.....	36

1. SPECIFICATIONS

Ceiling concealed (Medium static pressure type)

PEFY-M-VMA(L)-A1

Model			PEFY-M20VMA-A1	PEFY-M25VMA-A1	PEFY-M32VMA-A1	PEFY-M40VMA-A1	
Power source			1-phase 220-230-240 V 50 Hz	1-phase 220-230-240 V 50 Hz	1-phase 220-230-240 V 50 Hz	1-phase 220-230-240 V 50 Hz	
Cooling capacity (Nominal)	*1	kW	2.2	2.8	3.6	4.5	
	*1	BTU/h	7,500	9,600	12,300	15,400	
	*2	Power input	kW	0.039	0.039	0.060	0.087
	*2	Current input	A	0.34-0.33-0.32	0.34-0.33-0.32	0.50-0.48-0.46	0.70-0.67-0.64
Heating capacity (Nominal)	*3	kW	2.5	3.2	4.0	5.0	
	*3	BTU/h	8,500	10,900	13,600	17,100	
	*2	Power input	kW	0.037	0.037	0.058	0.085
	*2	Current input	A	0.34-0.33-0.32	0.34-0.33-0.32	0.50-0.48-0.46	0.70-0.67-0.64
External finish			Galvanized steel plate	Galvanized steel plate	Galvanized steel plate	Galvanized steel plate	
External dimension H x W x D			mm	250 x 700 x 732	250 x 700 x 732	250 x 700 x 732	
			in.	9-7/8 x 27-9/16 x 28-7/8	9-7/8 x 27-9/16 x 28-7/8	9-7/8 x 27-9/16 x 28-7/8	9-7/8 x 35-7/16 x 28-7/8
Net weight			kg (lbs)	21.0 (46.5)	21.0 (46.5)	21.0 (46.5)	
Heat exchanger			Cross fin (Aluminum fin and copper tube)	Cross fin (Aluminum fin and copper tube)	Cross fin (Aluminum fin and copper tube)	Cross fin (Aluminum fin and copper tube)	
FAN	Type x Quantity		Sirocco fan x 1	Sirocco fan x 1	Sirocco fan x 1	Sirocco fan x 2	
	*4	External static press.	Pa	35 - <50> - <70> - <100> - <150>	35 - <50> - <70> - <100> - <150>	35 - <50> - <70> - <100> - <150>	35 - <50> - <70> - <100> - <150>
			mmH ₂ O	3.6 - <5.1> - <7.1> - <10.2> - <15.3>	3.6 - <5.1> - <7.1> - <10.2> - <15.3>	3.6 - <5.1> - <7.1> - <10.2> - <15.3>	3.6 - <5.1> - <7.1> - <10.2> - <15.3>
	Motor Type		DC motor	DC motor	DC motor	DC motor	
	Motor output		kW	0.085	0.085	0.085	0.121
	Driving mechanism		Direct-driven by motor	Direct-driven by motor	Direct-driven by motor	Direct-driven by motor	
	*2	Air flow rate		(Low-Mid2-Mid1-High)	(Low-Mid2-Mid1-High)	(Low-Mid2-Mid1-High)	(Low-Mid2-Mid1-High)
		Cooling	m ³ /min	6.0 - 7.5 - 8.5 - 10	6.0 - 7.5 - 8.5 - 10	7.4 - 9.0 - 10.5 - 12.5	10.0 - 11.5 - 13.5 - 19.0
			L/s	100 - 125 - 142 - 166	100 - 125 - 142 - 166	123 - 150 - 175 - 208	166 - 191 - 225 - 316
			cfm	212 - 265 - 300 - 353	212 - 265 - 300 - 353	261 - 317 - 370 - 441	353 - 406 - 476 - 670
Heating		m ³ /min	6.0 - 7.5 - 8.5 - 10	6.0 - 7.5 - 8.5 - 10	7.4 - 9.0 - 10.5 - 12.5	10.0 - 11.5 - 13.5 - 19.0	
		L/s	100 - 125 - 142 - 166	100 - 125 - 142 - 166	123 - 150 - 175 - 208	166 - 191 - 225 - 316	
	cfm	212 - 265 - 300 - 353	212 - 265 - 300 - 353	261 - 317 - 370 - 441	353 - 406 - 476 - 670		
Sound pressure level (measured in anechoic room)			(Low-Mid2-Mid1-High)	(Low-Mid2-Mid1-High)	(Low-Mid2-Mid1-High)	(Low-Mid2-Mid1-High)	
*5	Cooling	dB <A>	21.5-23.0-26.5-30.0	21.5-23.0-26.5-30.0	24.0-28.0-31.5-35.5	23.5-25.5-28.5-37.0	
	Heating	dB <A>	21.5-23.0-26.5-30.0	21.5-23.0-26.5-30.0	24.0-28.0-31.5-35.5	23.5-25.5-28.5-37.0	
Insulation material			EPS, Polystyrene foam, Urethane foam	EPS, Polystyrene foam, Urethane foam	EPS, Polystyrene foam, Urethane foam	EPS, Polystyrene foam, Urethane foam	
Air filter			PP honeycomb fabric.	PP honeycomb fabric.	PP honeycomb fabric.	PP honeycomb fabric.	
Protection device			Fuse	Fuse	Fuse	Fuse	
Refrigerant control device			LEV	LEV	LEV	LEV	
Connectable outdoor unit			R32, R410A CITY MULTI	R32,R410A CITY MULTI	R32, R410A CITY MULTI	R32, R410A CITY MULTI	
Refrigerant piping diameter	Liquid	mm (in.)	6.35 (1/4)Braze	6.35 (1/4)Braze	6.35 (1/4)Braze	6.35 (1/4)Braze	
	Gas	mm (in.)	12.7 (1/2)Braze	12.7 (1/2)Braze	12.7 (1/2)Braze	12.7 (1/2)Braze	
Field drain pipe size			mm (in.)	O.D.32 (1-1/4")	O.D.32 (1-1/4")	O.D.32 (1-1/4")	
Drawing	External		KB94C4X9	KB94C4X9	KB94C4X9	KB94C4X9	
	Wiring		KB94C4X7	KB94C4X7	KB94C4X7	KB94C4X7	
	Refrigerant cycle		-	-	-	-	
Standard attachment	Document		Installation Manual, Instruction Book	Installation Manual, Instruction Book	Installation Manual, Instruction Book	Installation Manual, Instruction Book	
	Accessory		Washer, Drain hose, Tie band	Washer, Drain hose, Tie band	Washer, Drain hose, Tie band	Washer, Drain hose, Tie band	
Optional parts	Filter box		PAC-KE91TB-E	PAC-KE91TB-E	PAC-KE91TB-E	PAC-KE92TB-E	
	Plasma Quad Connect		MAC-100FT-E	MAC-100FT-E	MAC-100FT-E	MAC-100FT-E	
	PQ attachment (Rear inlet)		PAC-HA31PAR	PAC-HA31PAR	PAC-HA31PAR	PAC-HA31PAR	
	PQ attachment (Bottom inlet)		PAC-HA31PAU	PAC-HA31PAU	PAC-HA31PAU	PAC-HA31PAU	
	PQ box		PAC-KE91PTB-E	PAC-KE91PTB-E	PAC-KE91PTB-E	PAC-KE92PTB-E	
Remarks			* Details on foundation work, duct work, insulation work, electrical wiring, power source switch, and other items shall be referred to the Installation Manual. * Due to continuing improvement, above specifications may be subject to change without notice.				

Notes:	Unit converter
1.Nominal cooling conditions Indoor:27°CDB/19°CWB (81°FDB/66°FWB), Outdoor:35°CDB (95°FDB) Pipe length:7.5m (24-9/16ft.), Level difference:0m (0ft.)	BTU/h =kW x 3,412
2.The values are measured at the factory setting of external static pressure. The Air flow rate is measured by the conventional method in JIS.	cfm =m ³ /min x 35.31
3.Nominal heating conditions Indoor:20°CDB (68°FDB), Outdoor:7°CDB/6°CWB (45°FDB/43°FWB) Pipe length:7.5m (24-9/16ft.), Level difference:0m (0ft.)	lbs =kg/0.4536
4.The factory setting of airflow mode and external static pressure mode is shown without < > . Refer to "Fan characteristics curves", according to the external static pressure, in DATA BOOK for the usable range of air flow rate.	
5.Measured in anechoic room with a 1 m air inlet duct and 2 m air outlet duct attached to the unit and 1.5 m below the unit, under the conditions shown in *2.	*Above specification data is subject to rounding variation.

1. SPECIFICATIONS

Ceiling concealed (Medium static pressure type)

Model		PEFY-M50VMA-A1		PEFY-M63VMA-A1		PEFY-M71VMA-A1		PEFY-M80VMA-A1			
Power source		1-phase 220-230-240 V 50 Hz		1-phase 220-230-240 V 50 Hz		1-phase 220-230-240 V 50 Hz		1-phase 220-230-240 V 50 Hz			
Cooling capacity (Nominal)	*1	kW	5.6		7.1		8.0		9.0		
		BTU/h	19,100		24,200		27,300		30,700		
	*2	Power input	0.131		0.139		0.165		0.165		
		Current input	0.94-0.90-0.86		0.99-0.95-0.91		1.16-1.11-1.06		1.16-1.11-1.06		
Heating capacity (Nominal)	*3	kW	6.3		8.0		9.0		10.0		
		BTU/h	21,500		27,300		30,700		34,100		
	*2	Power input	0.129		0.231		0.216		0.216		
		Current input	0.94-0.90-0.86		1.55-1.48-1.42		1.47-1.41-1.35		1.47-1.41-1.35		
External finish		Galvanized steel plate		Galvanized steel plate		Galvanized steel plate		Galvanized steel plate			
External dimension H x W x D		mm	250 x 1,100 x 732		250 x 1,100 x 732		250 x 1,400 x 732		250 x 1,400 x 732		
		in.	9-7/8 x 43-5/16 x 28-7/8		9-7/8 x 43-5/16 x 28-7/8		9-7/8 x 55-1/8 x 28-7/8		9-7/8 x 55-1/8 x 28-7/8		
Net weight		kg (lbs)	30.0 (66.0)		30.0 (66.0)		37 (82)		37 (82)		
Heat exchanger		Cross fin (Aluminum fin and copper tube)		Cross fin (Aluminum fin and copper tube)		Cross fin (Aluminum fin and copper tube)		Cross fin (Aluminum fin and copper tube)			
FAN	Type x Quantity		Sirocco fan x 2		Sirocco fan x 2		Sirocco fan x 3		Sirocco fan x 3		
	*4	External static press.	Pa	35 - <50> - <70> - <100> - <150>		35 - <50> - <70> - <100> - <150>		40 - <50> - <70> - <100> - <150>		40 - <50> - <70> - <100> - <150>	
			mmH ₂ O	3.6 - <5.1> - <7.1> - <10.2> - <15.3>		3.6 - <5.1> - <7.1> - <10.2> - <15.3>		4.1 - <5.1> - <7.1> - <10.2> - <15.3>		4.1 - <5.1> - <7.1> - <10.2> - <15.3>	
	Motor Type		DC motor		DC motor		DC motor		DC motor		
	Motor output		kW		0.121		0.121		0.300		
	Driving mechanism		Direct-driven by motor		Direct-driven by motor		Direct-driven by motor		Direct-driven by motor		
	*2	Air flow rate		(Low-Mid2-Mid1-High)		(Low-Mid2-Mid1-High)		(Low-Mid2-Mid1-High)		(Low-Mid2-Mid1-High)	
		Cooling	m ³ /min	12.0 - 14.5 - 16.5 - 25.6		13.5 - 16.0 - 19.2 - 26.2		14.5 - 18.0 - 21.0 - 33.1		14.5 - 18.0 - 21.0 - 33.1	
			L/s	208 - 241 - 275 - 426		225 - 266 - 320 - 436		241 - 300 - 350 - 518		241 - 300 - 350 - 518	
			cfm	441 - 511 - 582 - 903		476 - 564 - 677 - 925		511 - 635 - 741 - 1098		511 - 635 - 741 - 1098	
Heating		m ³ /min	12.0 - 14.5 - 16.5 - 25.6		13.5 - 16.0 - 19.2 - 31.0		14.5 - 18.0 - 21.0 - 36.6		14.5 - 18.0 - 21.0 - 36.6		
		L/s	208 - 241 - 275 - 426		225 - 266 - 320 - 516		241 - 300 - 350 - 610		241 - 300 - 350 - 610		
	cfm	441 - 511 - 582 - 903		476 - 564 - 677 - 1094		511 - 635 - 741 - 1292		511 - 635 - 741 - 1292			
Sound pressure level (measured in anechoic room)		(Low-Mid2-Mid1-High)		(Low-Mid2-Mid1-High)		(Low-Mid2-Mid1-High)		(Low-Mid2-Mid1-High)			
*5	Cooling	dB <A>		22.0-24.0-26.5-37.0		23.0-26.0-30.0-37.5		22.0-25.0-27.5-38.5			
	Heating	dB <A>		22.0-24.0-26.5-37.0		23.0-26.0-30.0-41.5		22.0-25.0-27.5-40.5			
Insulation material		EPS, Polystyrene foam, Urethane foam		EPS, Polystyrene foam, Urethane foam		EPS, Polystyrene foam, Urethane foam		EPS, Polystyrene foam, Urethane foam			
Air filter		PP honeycomb fabric.		PP honeycomb fabric.		PP honeycomb fabric.		PP honeycomb fabric.			
Protection device		Fuse		Fuse		Fuse		Fuse			
Refrigerant control device		LEV		LEV		LEV		LEV			
Connectable outdoor unit		R32, R410A CITY MULTI		R32, R410A CITY MULTI		R32, R410A CITY MULTI		R32, R410A CITY MULTI			
Refrigerant piping diameter	Liquid	mm (in.)	6.35 (1/4)Braze		9.52 (3/8)Braze		9.52 (3/8)Braze		9.52 (3/8)Braze		
	Gas	mm (in.)	12.7 (1/2)Braze		15.88 (5/8)Braze		15.88 (5/8)Braze		15.88 (5/8)Braze		
Field drain pipe size		mm (in.)	O.D.32 (1-1/4")		O.D.32 (1-1/4")		O.D.32 (1-1/4")		O.D.32 (1-1/4")		
Drawing	External		KB94C4X9		KB94C4X9		KB94C4X9		KB94C4X9		
	Wiring		KB94C4X7		KB94C4X7		KB94C4X7		KB94C4X7		
	Refrigerant cycle		-		-		-		-		
Standard attachment	Document		Installation Manual, Instruction Book		Installation Manual, Instruction Book		Installation Manual, Instruction Book		Installation Manual, Instruction Book		
	Accessory		Washer, Drain hose, Tie band		Washer, Drain hose, Tie band		Washer, Drain hose, Tie band		Washer, Drain hose, Tie band		
Optional parts	Filter box		PAC-KE93TB-E		PAC-KE93TB-E		PAC-KE94TB-E		PAC-KE94TB-E		
	Plasma Quad Connect		MAC-100FT-E		MAC-100FT-E		MAC-100FT-E		MAC-100FT-E		
	PQ attachment (Rear inlet)		PAC-HA31PAR		PAC-HA31PAR		PAC-HA31PAR		PAC-HA31PAR		
	PQ attachment (Bottom inlet)		PAC-HA31PAU		PAC-HA31PAU		PAC-HA31PAU		PAC-HA31PAU		
	PQ box		PAC-KE93PTB-E		PAC-KE93PTB-E		PAC-KE94PTB-E		PAC-KE94PTB-E		
Remarks		<p>* Details on foundation work, duct work, insulation work, electrical wiring, power source switch, and other items shall be referred to the Installation Manual.</p> <p>* Due to continuing improvement, above specifications may be subject to change without notice.</p>									

Notes:	Unit converter
1. Nominal cooling conditions Indoor: 27°CDB/19°CWB (81°FDB/66°FWB), Outdoor: 35°CDB (95°FDB) Pipe length: 7.5m (24-9/16ft.), Level difference: 0m (0ft.)	BTU/h = kW x 3.412
2. The values are measured at the factory setting of external static pressure. The Air flow rate is measured by the conventional method in JIS.	cfm = m ³ /min x 35.31
3. Nominal heating conditions Indoor: 20°CDB (68°FDB), Outdoor: 7°CDB/6°CWB (45°FDB/43°FWB) Pipe length: 7.5m (24-9/16ft.), Level difference: 0m (0ft.)	lbs = kg/0.4536
4. The factory setting of airflow mode and external static pressure mode is shown without < >. Refer to "Fan characteristics curves", according to the external static pressure, in DATA BOOK for the usable range of air flow rate.	
5. Measured in anechoic room with a 1 m air inlet duct and 2 m air outlet duct attached to the unit and 1.5 m below the unit, under the conditions shown in *2.	*Above specification data is subject to rounding variation.

1. SPECIFICATIONS

Ceiling concealed (Medium static pressure type)

PEFY-M-VMA(L)-A1

Model		PEFY-M100VMA-A1	PEFY-M125VMA-A1	PEFY-M140VMA-A1	
Power source		1-phase 220-230-240 V 50 Hz	1-phase 220-230-240 V 50 Hz	1-phase 220-230-240 V 50 Hz	
Cooling capacity (Nominal)	*1 kW	11.2	14.0	16.0	
	*1 BTU/h	38,200	47,800	54,600	
	*2 Power input kW	0.211	0.218	0.282	
	*2 Current input A	1.44-1.38-1.32	1.40-1.33-1.28	1.84-1.76-1.69	
Heating capacity (Nominal)	*3 kW	12.5	16.0	18.0	
	*3 BTU/h	42,700	54,600	61,400	
	*2 Power input kW	0.209	0.216	0.280	
	*2 Current input A	1.44-1.38-1.32	1.40-1.33-1.28	1.84-1.76-1.69	
External finish		Galvanized steel plate	Galvanized steel plate	Galvanized steel plate	
External dimension H x W x D		mm	250 x 1,400 x 732	250 x 1,400 x 732	
		in.	9-7/8 x 55-1/8 x 28-7/8	9-7/8 x 55-1/8 x 28-7/8	
Net weight		kg (lbs)	37 (82)	38 (84)	
Heat exchanger		Cross fin (Aluminum fin and copper tube)	Cross fin (Aluminum fin and copper tube)	Cross fin (Aluminum fin and copper tube)	
FAN		Sirocco fan x 3	Sirocco fan x 3	Sirocco fan x 3	
*4 External static press.	Pa	40 - <50> - <70> - <100> - <150>	<40> - 50 - <70> - <100> - <150>	<40> - 50 - <70> - <100> - <150>	
		mmH ₂ O	4.1 - <5.1> - <7.1> - <10.2> - <15.3>	<4.1> - 5.1 - <7.1> - <10.2> - <15.3>	<4.1> - 5.1 - <7.1> - <10.2> - <15.3>
Motor Type		DC motor	DC motor	DC motor	
Motor output kW		0.300	0.300	0.300	
Driving mechanism		Direct-driven by motor	Direct-driven by motor	Direct-driven by motor	
*2 Air flow rate	(Low-Mid2-Mid1-High)		(Low-Mid2-Mid1-High)	(Low-Mid2-Mid1-High)	
	Cooling	m ³ /min	23.0 - 28.0 - 32.0 - 37.0	25.5 - 31.0 - 34.0 - 37.0	29.5 - 35.5 - 40.0 - 44.0
		L/s	383 - 466 - 533 - 616	425 - 516 - 566 - 616	491 - 591 - 666 - 733
		cfm	812 - 988 - 1129 - 1306	900 - 1094 - 1200 - 1306	1041 - 1253 - 1412 - 1553
	Heating	m ³ /min	23.0 - 28.0 - 32.0 - 37.0	25.5 - 31.0 - 34.0 - 37.0	29.5 - 35.5 - 40.0 - 44.0
		L/s	383 - 466 - 533 - 616	425 - 516 - 566 - 616	491 - 591 - 666 - 733
cfm		812 - 988 - 1129 - 1306	900 - 1094 - 1200 - 1306	1041 - 1253 - 1412 - 1553	
Sound pressure level (measured in anechoic room)		(Low-Mid2-Mid1-High)	(Low-Mid2-Mid1-High)	(Low-Mid2-Mid1-High)	
*5 Cooling	dB <A>	29.5-34.0-37.5-40.0	31.5-36.5-38.5-40.5	34.0-38.0-40.5-43.0	
	dB <A>	29.5-34.0-37.5-40.0	31.5-36.5-38.5-40.5	34.0-38.0-40.5-43.0	
Insulation material		EPS, Polystyrene foam, Urethane foam	EPS, Polystyrene foam, Urethane foam	EPS, Polystyrene foam, Urethane foam	
Air filter		PP honeycomb fabric.	PP honeycomb fabric.	PP honeycomb fabric.	
Protection device		Fuse	Fuse	Fuse	
Refrigerant control device		LEV	LEV	LEV	
Connectable outdoor unit		R32, R410A CITY MULTI	R32, R410A CITY MULTI	R32, R410A CITY MULTI	
Refrigerant piping diameter	Liquid mm (in.)	9.52 (3/8)Braze	9.52 (3/8)Braze	9.52 (3/8)Braze	
	Gas mm (in.)	15.88 (5/8)Braze	15.88 (5/8)Braze	15.88 (5/8)Braze	
Field drain pipe size		mm (in.)	O.D.32 (1-1/4")	O.D.32 (1-1/4")	
Drawing	External	KB94C4X9	KB94C4X9	KB94C4X9	
	Wiring	KB94C4X7	KB94C4X7	KB94C4X7	
	Refrigerant cycle	-	-	-	
Standard attachment	Document	Installation Manual, Instruction Book	Installation Manual, Instruction Book	Installation Manual, Instruction Book	
	Accessory	Washer, Drain hose, Tie band	Washer, Drain hose, Tie band	Washer, Drain hose, Tie band	
Optional parts	Filter box	PAC-KE94TB-E	PAC-KE94TB-E	PAC-KE95TB-E	
	Plasma Quad Connect	MAC-100FT-E	MAC-100FT-E	MAC-100FT-E	
	PQ attachment (Rear inlet)	PAC-HA31PAR	PAC-HA31PAR	PAC-HA31PAR	
	PQ attachment (Bottom inlet)	PAC-HA31PAU	PAC-HA31PAU	PAC-HA31PAU	
	PQ box	PAC-KE94PTB-E	PAC-KE94PTB-E	PAC-KE95PTB-E	
Remarks		* Details on foundation work, duct work, insulation work, electrical wiring, power source switch, and other items shall be referred to the Installation Manual. * Due to continuing improvement, above specifications may be subject to change without notice.			

Notes:	Unit converter
1.Nominal cooling conditions Indoor:27°CDB/19°CWB (81°FDB/66°FWB), Outdoor:35°CDB (95°FDB) Pipe length:7.5m (24-9/16ft.), Level difference:0m (0ft.)	BTU/h =kW x 3,412
2.The values are measured at the factory setting of external static pressure. The Air flow rate is measured by the conventional method in JIS.	cfm =m ³ /min x 35.31
3.Nominal heating conditions Indoor:20°CDB (68°FDB), Outdoor:7°CDB/6°CWB (45°FDB/43°FWB) Pipe length:7.5m (24-9/16ft.), Level difference:0m (0ft.)	lbs =kg/0.4536
4.The factory setting of airflow mode and external static pressure mode is shown without < > . Refer to "Fan characteristics curves", according to the external static pressure, in DATA BOOK for the usable range of air flow rate.	
5.Measured in anechoic room with a 1 m air inlet duct and 2 m air outlet duct attached to the unit and 1.5 m below the unit, under the conditions shown in *2.	*Above specification data is subject to rounding variation.

1. SPECIFICATIONS

Ceiling concealed (Medium static pressure type)

Model		PEFY-M20VMAL-A1	PEFY-M25VMAL-A1	PEFY-M32VMAL-A1	PEFY-M40VMAL-A1	
Power source		1-phase 220-230-240 V 50 Hz	1-phase 220-230-240 V 50 Hz	1-phase 220-230-240 V 50 Hz	1-phase 220-230-240 V 50 Hz	
Cooling capacity (Nominal)	*1	kW	2.2	2.8	3.6	
	*1	BTU/h	7,500	9,600	12,300	
	*2	Power input	kW	0.037	0.058	0.085
	*2	Current input	A	0.34-0.33-0.32	0.34-0.33-0.32	0.50-0.48-0.46
Heating capacity (Nominal)	*3	kW	2.5	3.2	4.0	
	*3	BTU/h	8,500	10,900	13,600	
	*2	Power input	kW	0.037	0.058	0.085
	*2	Current input	A	0.34-0.33-0.32	0.34-0.33-0.32	0.50-0.48-0.46
External finish		Galvanized steel plate	Galvanized steel plate	Galvanized steel plate	Galvanized steel plate	
External dimension H x W x D		mm 250 x 700 x 732	mm 250 x 700 x 732	mm 250 x 700 x 732	mm 250 x 900 x 732	
		in. 9-7/8 x 27-9/16 x 28-7/8	in. 9-7/8 x 27-9/16 x 28-7/8	in. 9-7/8 x 27-9/16 x 28-7/8	in. 9-7/8 x 35-7/16 x 28-7/8	
Net weight		kg (lbs)	20.0 (44.0)	20.0 (44.0)	20.5 (45.0)	
Heat exchanger		Cross fin (Aluminum fin and copper tube)				
FAN		Sirocco fan x 1				
*4	Type x Quantity	Sirocco fan x 1				
	External static press.	Pa	35 - <50> - <70> - <100> - <150>	35 - <50> - <70> - <100> - <150>	35 - <50> - <70> - <100> - <150>	35 - <50> - <70> - <100> - <150>
		mmH ₂ O	3.6 - <5.1> - <7.1> - <10.2> - <15.3>	3.6 - <5.1> - <7.1> - <10.2> - <15.3>	3.6 - <5.1> - <7.1> - <10.2> - <15.3>	3.6 - <5.1> - <7.1> - <10.2> - <15.3>
	Motor Type	DC motor				
Motor output	kW	0.085	0.085	0.085	0.121	
Driving mechanism		Direct-driven by motor				
*2	Air flow rate	(Low-Mid2-Mid1-High)				
	Cooling	m ³ /min	6.0 - 7.5 - 8.5 - 10	6.0 - 7.5 - 8.5 - 10	7.4 - 9.0 - 10.5 - 12.5	10.0 - 11.5 - 13.5 - 19.0
		L/s	100 - 125 - 142 - 166	100 - 125 - 142 - 166	123 - 150 - 175 - 208	166 - 191 - 225 - 316
		cfm	212 - 265 - 300 - 353	212 - 265 - 300 - 353	261 - 317 - 370 - 441	353 - 406 - 476 - 670
	Heating	m ³ /min	6.0 - 7.5 - 8.5 - 10	6.0 - 7.5 - 8.5 - 10	7.4 - 9.0 - 10.5 - 12.5	10.0 - 11.5 - 13.5 - 19.0
		L/s	100 - 125 - 142 - 166	100 - 125 - 142 - 166	123 - 150 - 175 - 208	166 - 191 - 225 - 316
cfm		212 - 265 - 300 - 353	212 - 265 - 300 - 353	261 - 317 - 370 - 441	353 - 406 - 476 - 670	
Sound pressure level (measured in anechoic room)		(Low-Mid2-Mid1-High)				
*5	Cooling	dB <A>	21.5-23.0-26.5-30.0	21.5-23.0-26.5-30.0	24.0-28.0-31.5-35.5	23.5-25.5-28.5-37.0
	Heating	dB <A>	21.5-23.0-26.5-30.0	21.5-23.0-26.5-30.0	24.0-28.0-31.5-35.5	23.5-25.5-28.5-37.0
Insulation material		EPS, Polystyrene foam, Urethane foam				
Air filter		PP honeycomb fabric.				
Protection device		Fuse				
Refrigerant control device		LEV				
Connectable outdoor unit		R32, R410A CITY MULTI				
Refrigerant piping diameter	Liquid	mm (in.)	6.35 (1/4)Braze	6.35 (1/4)Braze	6.35 (1/4)Braze	6.35 (1/4)Braze
	Gas	mm (in.)	12.7 (1/2)Braze	12.7 (1/2)Braze	12.7 (1/2)Braze	12.7 (1/2)Braze
Field drain pipe size		mm (in.)	O.D.32 (1-1/4")	O.D.32 (1-1/4")	O.D.32 (1-1/4")	O.D.32 (1-1/4")
Drawing	External	KB94C4XA				
	Wiring	KB94C4X7				
	Refrigerant cycle	-				
Standard attachment	Document	Installation Manual, Instruction Book				
	Accessory	Washer, Drain hose, Tie band				
Optional parts	Filter box	PAC-KE91TB-E				
	Plasma Quad Connect	MAC-100FT-E				
	PQ attachment (Rear inlet)	PAC-HA31PAR				
	PQ attachment (Bottom inlet)	PAC-HA31PAU				
	PQ box	PAC-KE91PTB-E				
Remarks		* Details on foundation work, duct work, insulation work, electrical wiring, power source switch, and other items shall be referred to the Installation Manual. * Due to continuing improvement, above specifications may be subject to change without notice.				

Notes:	Unit converter
1. Nominal cooling conditions Indoor: 27°CDB/19°CWB (81°FDB/66°FWB), Outdoor: 35°CDB (95°FDB) Pipe length: 7.5m (24-9/16ft.), Level difference: 0m (0ft.)	BTU/h = kW x 3,412
2. The values are measured at the factory setting of external static pressure. The Air flow rate is measured by the conventional method in JIS.	cfm = m ³ /min x 35.31
3. Nominal heating conditions Indoor: 20°CDB (68°FDB), Outdoor: 7°CDB/6°CWB (45°FDB/43°FWB) Pipe length: 7.5m (24-9/16ft.), Level difference: 0m (0ft.)	lbs = kg/0.4536
4. The factory setting of airflow mode and external static pressure mode is shown without < >. Refer to "Fan characteristics curves", according to the external static pressure, in DATA BOOK for the usable range of air flow rate.	
5. Measured in anechoic room with a 1 m air inlet duct and 2 m air outlet duct attached to the unit and 1.5 m below the unit, under the conditions shown in *2.	*Above specification data is subject to rounding variation.

1. SPECIFICATIONS

Ceiling concealed (Medium static pressure type)

PEFY-M-VMA(L)-A1

Model		PEFY-M50VMAL-A1	PEFY-M63VMAL-A1	PEFY-M71VMAL-A1	PEFY-M80VMAL-A1		
Power source		1-phase 220-230-240 V 50 Hz	1-phase 220-230-240 V 50 Hz	1-phase 220-230-240 V 50 Hz	1-phase 220-230-240 V 50 Hz		
Cooling capacity (Nominal)	*1 kW	5.6	7.1	8.0	9.0		
	*1 BTU/h	19,100	24,200	27,300	30,700		
	*2 Power input kW	0.129	0.137	0.163	0.163		
	*2 Current input A	0.94-0.90-0.86	0.99-0.95-0.91	1.16-1.11-1.06	1.16-1.11-1.06		
Heating capacity (Nominal)	*3 kW	6.3	8.0	9.0	10.0		
	*3 BTU/h	21,500	27,300	30,700	34,100		
	*2 Power input kW	0.129	0.231	0.216	0.216		
	*2 Current input A	0.94-0.90-0.86	1.55-1.48-1.42	1.47-1.41-1.35	1.47-1.41-1.35		
External finish		Galvanized steel plate	Galvanized steel plate	Galvanized steel plate	Galvanized steel plate		
External dimension H x W x D		mm	250 x 1,100 x 732	250 x 1,100 x 732	250 x 1,400 x 732		
		in.	9-7/8 x 43-5/16 x 28-7/8	9-7/8 x 43-5/16 x 28-7/8	9-7/8 x 55-1/8 x 28-7/8	9-7/8 x 55-1/8 x 28-7/8	
Net weight		kg (lbs)	29.0 (64.0)	29.0 (64.0)	36 (80)		
Heat exchanger		Cross fin (Aluminum fin and copper tube)	Cross fin (Aluminum fin and copper tube)	Cross fin (Aluminum fin and copper tube)	Cross fin (Aluminum fin and copper tube)		
FAN	Type x Quantity		Sirocco fan x 2	Sirocco fan x 2	Sirocco fan x 3	Sirocco fan x 3	
	*4 External static press.	Pa	35 - <50> - <70> - <100> - <150>	35 - <50> - <70> - <100> - <150>	40 - <50> - <70> - <100> - <150>	40 - <50> - <70> - <100> - <150>	
		mmH ₂ O	3.6 - <5.1> - <7.1> - <10.2> - <15.3>	3.6 - <5.1> - <7.1> - <10.2> - <15.3>	4.1 - <5.1> - <7.1> - <10.2> - <15.3>	4.1 - <5.1> - <7.1> - <10.2> - <15.3>	
	Motor Type		DC motor	DC motor	DC motor	DC motor	
	Motor output kW		0.121	0.121	0.300	0.300	
	Driving mechanism		Direct-driven by motor	Direct-driven by motor	Direct-driven by motor	Direct-driven by motor	
	*2 Air flow rate	(Low-Mid2-Mid1-High)		(Low-Mid2-Mid1-High)	(Low-Mid2-Mid1-High)	(Low-Mid2-Mid1-High)	
		Cooling	m ³ /min	12.0 - 14.5 - 16.5 - 25.6	13.5 - 16.0 - 19.2 - 26.2	14.5 - 18.0 - 21.0 - 33.1	14.5 - 18.0 - 21.0 - 33.1
			L/s	208 - 241 - 275 - 426	225 - 266 - 320 - 436	241 - 300 - 350 - 518	241 - 300 - 350 - 518
			cfm	441 - 511 - 582 - 903	476 - 564 - 677 - 925	511 - 635 - 741 - 1098	511 - 635 - 741 - 1098
Heating		m ³ /min	12.0 - 14.5 - 16.5 - 25.6	13.5 - 16.0 - 19.2 - 31.0	14.5 - 18.0 - 21.0 - 36.6	14.5 - 18.0 - 21.0 - 36.6	
		L/s	208 - 241 - 275 - 426	225 - 266 - 320 - 516	241 - 300 - 350 - 610	241 - 300 - 350 - 610	
	cfm	441 - 511 - 582 - 903	476 - 564 - 677 - 1094	511 - 635 - 741 - 1292	511 - 635 - 741 - 1292		
Sound pressure level (measured in anechoic room)		(Low-Mid2-Mid1-High)	(Low-Mid2-Mid1-High)	(Low-Mid2-Mid1-High)	(Low-Mid2-Mid1-High)		
*5	Cooling dB <A>	22.0-24.0-26.5-37.0	23.0-26.0-30.0-37.5	22.0-25.0-27.5-38.5	22.0-25.0-27.5-38.5		
	Heating dB <A>	22.0-24.0-26.5-37.0	23.0-26.0-30.0-41.5	22.0-25.0-27.5-40.5	22.0-25.0-27.5-40.5		
Insulation material		EPS, Polystyrene foam, Urethane foam	EPS, Polystyrene foam, Urethane foam	EPS, Polystyrene foam, Urethane foam	EPS, Polystyrene foam, Urethane foam		
Air filter		PP honeycomb fabric.	PP honeycomb fabric.	PP honeycomb fabric.	PP honeycomb fabric.		
Protection device		Fuse	Fuse	Fuse	Fuse		
Refrigerant control device		LEV	LEV	LEV	LEV		
Connectable outdoor unit		R32, R410A CITY MULTI	R32, R410A CITY MULTI	R32, R410A CITY MULTI	R32, R410A CITY MULTI		
Refrigerant piping diameter	Liquid mm (in.)	6.35 (1/4)Braze	9.52 (3/8)Braze	9.52 (3/8)Braze	9.52 (3/8)Braze		
	Gas mm (in.)	12.7 (1/2)Braze	15.88 (5/8)Braze	15.88 (5/8)Braze	15.88 (5/8)Braze		
Field drain pipe size		mm (in.)	O.D.32 (1-1/4")	O.D.32 (1-1/4")	O.D.32 (1-1/4")		
Drawing	External	KB94C4XA	KB94C4XA	KB94C4XA	KB94C4XA		
	Wiring	KB94C4X7	KB94C4X7	KB94C4X7	KB94C4X7		
	Refrigerant cycle	-	-	-	-		
Standard attachment	Document	Installation Manual, Instruction Book	Installation Manual, Instruction Book	Installation Manual, Instruction Book	Installation Manual, Instruction Book		
	Accessory	Washer, Drain hose, Tie band	Washer, Drain hose, Tie band	Washer, Drain hose, Tie band	Washer, Drain hose, Tie band		
Optional parts	Filter box	PAC-KE93TB-E	PAC-KE93TB-E	PAC-KE94TB-E	PAC-KE94TB-E		
	Plasma Quad Connect	MAC-100FT-E	MAC-100FT-E	MAC-100FT-E	MAC-100FT-E		
	PQ attachment (Rear inlet)	PAC-HA31PAR	PAC-HA31PAR	PAC-HA31PAR	PAC-HA31PAR		
	PQ attachment (Bottom inlet)	PAC-HA31PAU	PAC-HA31PAU	PAC-HA31PAU	PAC-HA31PAU		
	PQ box	PAC-KE93PTB-E	PAC-KE93PTB-E	PAC-KE94PTB-E	PAC-KE94PTB-E		
Remarks		* Details on foundation work, duct work, insulation work, electrical wiring, power source switch, and other items shall be referred to the Installation Manual. * Due to continuing improvement, above specifications may be subject to change without notice.					

Notes:	Unit converter
1.Nominal cooling conditions Indoor:27°CDB/19°CWB (81°FDB/66°FWB), Outdoor:35°CDB (95°FDB) Pipe length:7.5m (24-9/16ft.), Level difference:0m (0ft.)	BTU/h =kW x 3,412
2.The values are measured at the factory setting of external static pressure. The Air flow rate is measured by the conventional method in JIS.	cfm =m ³ /min x 35.31
3.Nominal heating conditions Indoor:20°CDB (68°FDB), Outdoor:7°CDB/6°CWB (45°FDB/43°FWB) Pipe length:7.5m (24-9/16ft.), Level difference:0m (0ft.)	lbs =kg/0.4536
4.The factory setting of airflow mode and external static pressure mode is shown without < > . Refer to "Fan characteristics curves", according to the external static pressure, in DATA BOOK for the usable range of air flow rate.	
5.Measured in anechoic room with a 1 m air inlet duct and 2 m air outlet duct attached to the unit and 1.5 m below the unit, under the conditions shown in *2.	*Above specification data is subject to rounding variation.

1. SPECIFICATIONS

Ceiling concealed (Medium static pressure type)

Model		PEFY-M100VMAL-A1	PEFY-M125VMAL-A1	PEFY-M140VMAL-A1		
Power source		1-phase 220-230-240 V 50 Hz	1-phase 220-230-240 V 50 Hz	1-phase 220-230-240 V 50 Hz		
Cooling capacity (Nominal)	*1 kW	11.2	14.0	16.0		
	*1 BTU/h	38,200	47,800	54,600		
	*2 Power input kW	0.209	0.216	0.280		
	*2 Current input A	1.44-1.38-1.32	1.40-1.33-1.28	1.84-1.76-1.69		
Heating capacity (Nominal)	*3 kW	12.5	16.0	18.0		
	*3 BTU/h	42,700	54,600	61,400		
	*2 Power input kW	0.209	0.216	0.280		
	*2 Current input A	1.44-1.38-1.32	1.40-1.33-1.28	1.84-1.76-1.69		
External finish		Galvanized steel plate	Galvanized steel plate	Galvanized steel plate		
External dimension H x W x D		mm	250 x 1,400 x 732	250 x 1,400 x 732		
		in.	9-7/8 x 55-1/8 x 28-7/8	9-7/8 x 55-1/8 x 28-7/8		
Net weight		kg (lbs)	36 (80)	37 (82)		
Heat exchanger		Cross fin (Aluminum fin and copper tube)	Cross fin (Aluminum fin and copper tube)	Cross fin (Aluminum fin and copper tube)		
FAN	Type x Quantity		Sirocco fan x 3	Sirocco fan x 3		
	*4 External static press.	Pa	40 - <50> - <70> - <100> - <150>	<40> - 50 - <70> - <100> - <150>	<40> - 50 - <70> - <100> - <150>	
		mmH ₂ O	4.1 - <5.1> - <7.1> - <10.2> - <15.3>	<4.1> - 5.1 - <7.1> - <10.2> - <15.3>	<4.1> - 5.1 - <7.1> - <10.2> - <15.3>	
	Motor Type		DC motor	DC motor	DC motor	
	Motor output kW		0.300	0.300	0.300	
	Driving mechanism		Direct-driven by motor	Direct-driven by motor	Direct-driven by motor	
	*2 Air flow rate	(Low-Mid2-Mid1-High)		(Low-Mid2-Mid1-High)	(Low-Mid2-Mid1-High)	
		Cooling	m ³ /min	23.0 - 28.0 - 32.0 - 37.0	25.5 - 31.0 - 34.0 - 37.0	29.5 - 35.5 - 40.0 - 44.0
			L/s	383 - 466 - 533 - 616	425 - 516 - 566 - 616	491 - 591 - 666 - 733
			cfm	812 - 988 - 1129 - 1306	900 - 1094 - 1200 - 1306	1041 - 1253 - 1412 - 1553
Heating		m ³ /min	23.0 - 28.0 - 32.0 - 37.0	25.5 - 31.0 - 34.0 - 37.0	29.5 - 35.5 - 40.0 - 44.0	
		L/s	383 - 466 - 533 - 616	425 - 516 - 566 - 616	491 - 591 - 666 - 733	
	cfm	812 - 988 - 1129 - 1306	900 - 1094 - 1200 - 1306	1041 - 1253 - 1412 - 1553		
Sound pressure level (measured in anechoic room)		(Low-Mid2-Mid1-High)	(Low-Mid2-Mid1-High)	(Low-Mid2-Mid1-High)		
*5	Cooling dB <A>	29.5-34.0-37.5-40.0	31.5-36.5-38.5-40.5	34.0-38.0-40.5-43.0		
	Heating dB <A>	29.5-34.0-37.5-40.0	31.5-36.5-38.5-40.5	34.0-38.0-40.5-43.0		
Insulation material		EPS, Polystyrene foam, Urethane foam	EPS, Polystyrene foam, Urethane foam	EPS, Polystyrene foam, Urethane foam		
Air filter		PP honeycomb fabric.	PP honeycomb fabric.	PP honeycomb fabric.		
Protection device		Fuse	Fuse	Fuse		
Refrigerant control device		LEV	LEV	LEV		
Connectable outdoor unit		R32, R410A CITY MULTI	R32, R410A CITY MULTI	R32, R410A CITY MULTI		
Refrigerant piping diameter	Liquid mm (in.)	9.52 (3/8)Braze	9.52 (3/8)Braze	9.52 (3/8)Braze		
	Gas mm (in.)	15.88 (5/8)Braze	15.88 (5/8)Braze	15.88 (5/8)Braze		
Field drain pipe size		mm (in.)	O.D.32 (1-1/4")	O.D.32 (1-1/4")		
Drawing	External	KB94C4XA	KB94C4XA	KB94C4XA		
	Wiring	KB94C4X7	KB94C4X7	KB94C4X7		
	Refrigerant cycle	-	-	-		
Standard attachment	Document	Installation Manual, Instruction Book	Installation Manual, Instruction Book	Installation Manual, Instruction Book		
	Accessory	Washer, Drain hose, Tie band	Washer, Drain hose, Tie band	Washer, Drain hose, Tie band		
Optional parts	Filter box	PAC-KE94TB-E	PAC-KE94TB-E	PAC-KE95TB-E		
	Plasma Quad Connect	MAC-100FT-E	MAC-100FT-E	MAC-100FT-E		
	PQ attachment (Rear inlet)	PAC-HA31PAR	PAC-HA31PAR	PAC-HA31PAR		
	PQ attachment (Bottom inlet)	PAC-HA31PAU	PAC-HA31PAU	PAC-HA31PAU		
	PQ box	PAC-KE94PTB-E	PAC-KE94PTB-E	PAC-KE95PTB-E		
Remarks		* Details on foundation work, duct work, insulation work, electrical wiring, power source switch, and other items shall be referred to the Installation Manual. * Due to continuing improvement, above specifications may be subject to change without notice.				

Notes:	Unit converter
1. Nominal cooling conditions Indoor: 27°CDB/19°CWB (81°FDB/66°FWB), Outdoor: 35°CDB (95°FDB) Pipe length: 7.5m (24-9/16ft.), Level difference: 0m (0ft.)	BTU/h = kW x 3,412
2. The values are measured at the factory setting of external static pressure. The Air flow rate is measured by the conventional method in JIS.	cfm = m ³ /min x 35.31
3. Nominal heating conditions Indoor: 20°CDB (68°FDB), Outdoor: 7°CDB/6°CWB (45°FDB/43°FWB) Pipe length: 7.5m (24-9/16ft.), Level difference: 0m (0ft.)	lbs = kg/0.4536
4. The factory setting of airflow mode and external static pressure mode is shown without < >. Refer to "Fan characteristics curves", according to the external static pressure, in DATA BOOK for the usable range of air flow rate.	
5. Measured in anechoic room with a 1 m air inlet duct and 2 m air outlet duct attached to the unit and 1.5 m below the unit, under the conditions shown in *2.	*Above specification data is subject to rounding variation.

2. EXTERNAL DIMENSIONS

Ceiling concealed (Medium static pressure type)

PEFY-M20, 25, 32, 40, 50, 63, 71, 80, 100, 125, 140VMA-A1

Unit: mm

- Note 1. Use M10 screw for the Suspension bolt (field supply).
 2. Keep the service space for the maintenance at the bottom.
 3. This chart indicates for PEFY-M50-63VMA-A1 models, which have 2 fans. PEFY-M20-25-32VMA-A1 models have 1 fan. PEFY-M40VMA-A1 models have 2 fans. PEFY-M71-80-100-125-140VMA-A1 models have 3 fans.
 4. In case of the inlet duct is used, remove the air filter (supply with the unit), then install the filter (field supply) at suction side.

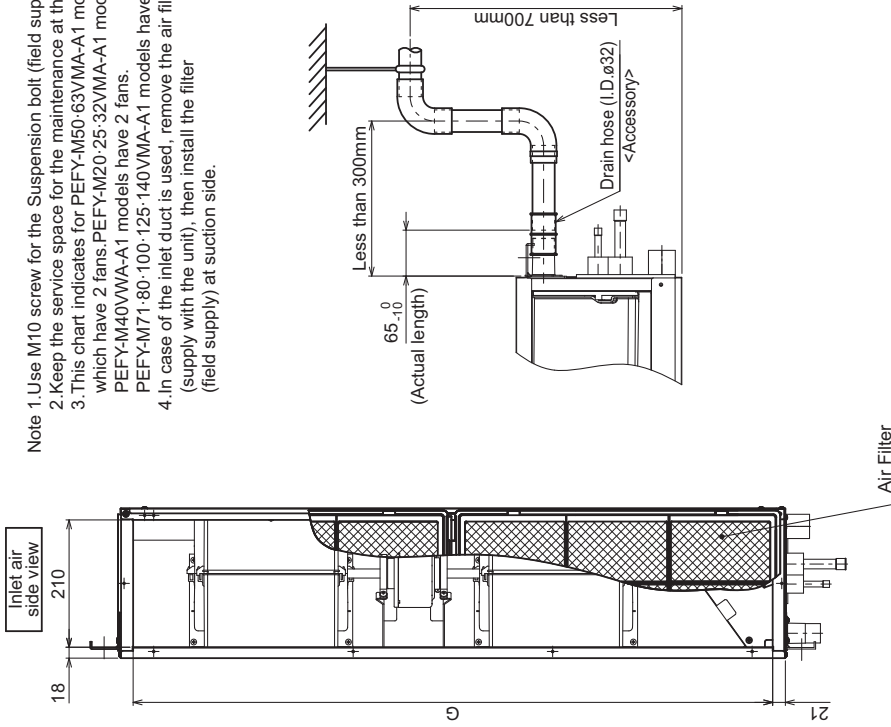

Model	A	B	C	D	E	F	G	① Gas pipe	② Liquid pipe
PEFY-M20, 25, 32VMA-A1	700	754	800	660	7	600	658	ø12.7	ø6.35
PEFY-M40VMA-A1	900	954	1000	860	9	800	858		
PEFY-M50VMA-A1	1100	1154	1200	1060	11	1000	1058		
PEFY-M63VMA-A1	1100	1154	1200	1060	11	1000	1058		
PEFY-M71, 80, 100, 125VMA-A1	1400	1454	1500	1360	14	1300	1358	ø15.88	ø9.52
PEFY-M140VMA-A1	1600	1654	1700	1560	16	1500	1558		

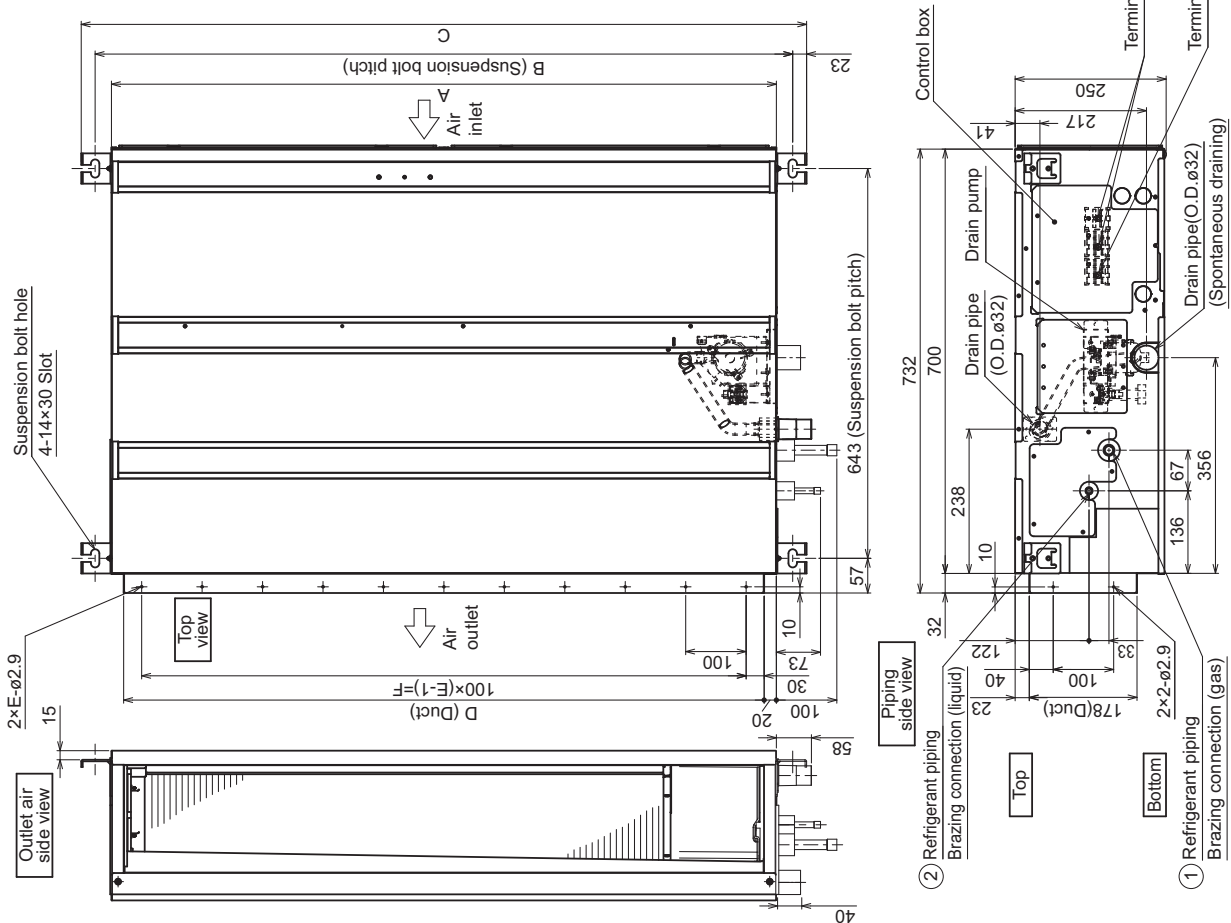

PEFY-M20, 25, 32, 40, 50, 63, 71, 80, 100, 125, 140VMA-A1

Unit: mm

[Maintenance access space]
 Secure enough access space to allow for the maintenance, inspection, and replacement of the motor, fan, drain pump, heat exchanger, and control box in one of the following ways.
 Select an installation site for the indoor unit so that its maintenance access space will not be obstructed by beams or other objects.

- (1) When a space of 300mm or more is available below the unit between the unit and the ceiling. (Fig.1)
- Create access door 1 and 2 (450×450mm each) as shown in Fig.2.
- (Access door 2 is not required if enough space is available below the unit for a maintenance worker to work in.)

(2) When a space of less than 300mm is available below the unit between the unit and the ceiling.

- (At least 20mm of space should be left below the unit as shown in Fig.3.)
- Create access door 1 diagonally below the control box and access door 3 below the unit as shown in Fig.4.
- or
- Create access door 4 below the control box and the unit as shown in Fig.5.

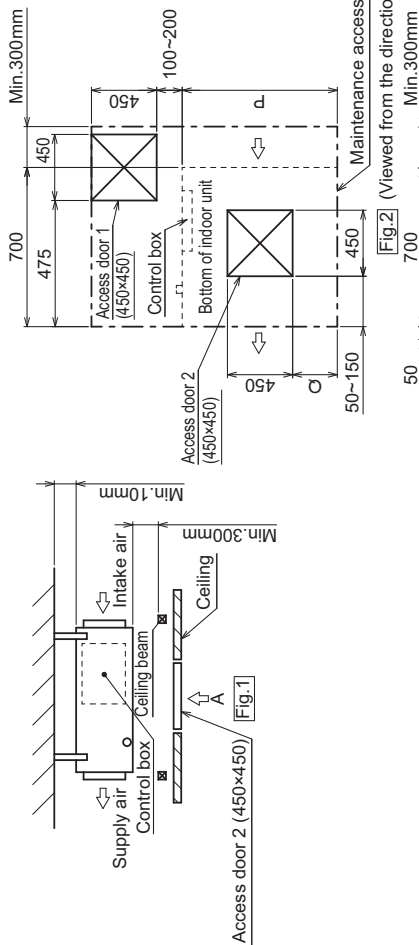

Fig.2 (Viewed from the direction of the arrow A)

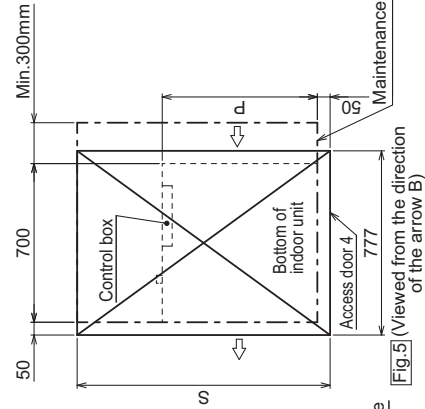

Fig.4 (Viewed from the direction of the arrow B)

Fig.5 (Viewed from the direction of the arrow B)

Model	H	J	K	L	M	N	P	Q	R	S
PEFY-M20, 25, 32VMA-A1	44	150	300	4	780	10	700	50-150	800	1300
PEFY-M40VMA-A1	54	260	4	990	10	900	150-250	1000	1500	1500
PEFY-M60, 63VMA-A1	49	330	4	1280	12	1100	250-350	1200	1700	1700
PEFY-M71, 80, 100, 125VMA-A1	54	320	5	1480	12	1400	400-500	1500	2000	2000
PEFY-M140VMA-A1	54	370	5	1480	12	1600	500-600	1700	2200	2200

2. EXTERNAL DIMENSIONS

Ceiling concealed (Medium static pressure type)

PEFY-M20, 25, 32, 40, 50, 63, 71, 80, 100, 125, 140VMA-A1 Suction filter box built-in-specification

Unit: mm

- Note 1. Use M10 screw for the Suspension bolt (field supply).
 2. Keep the service space for the maintenance at the bottom.
 3. This chart indicates for PEFY-M50-63VMA-A1 models, which have 2 fans. PEFY-M20-25-32VMA-A1 models have 1 fan. PEFY-M40VMA-A1 models have 2 fans. PEFY-M71-80-100-125-140VMA-A1 models have 3 fans.
 4. Use air filter installed with indoor unit.

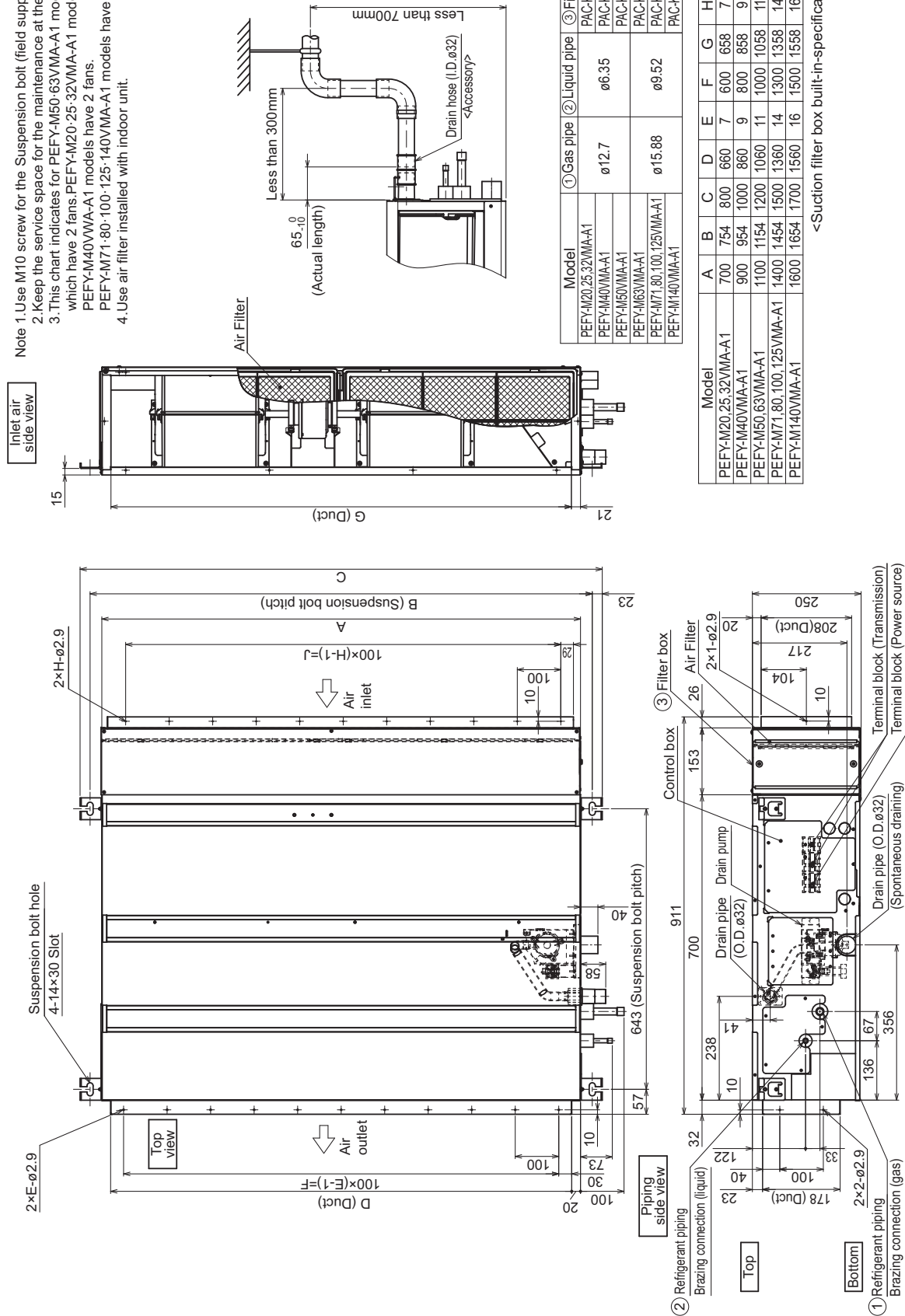

PEFY-M20, 25, 32, 40, 50, 63, 71, 80, 100, 125, 140VMA-A1 Suction filter box built-in-specification

Unit: mm

[Maintenance access space]
Secure enough access space to allow for the maintenance, inspection, and replacement of the motor, fan, drain pump, heat exchanger, and control box in one of the following ways.
Select an installation site for the indoor unit so that its maintenance access space will not be obstructed by beams or other objects.

- (1) When a space of 300mm or more is available below the unit between the unit and the ceiling. (Fig.1)
 - Create access door 1 and 2 (450×450mm each) as shown in Fig.2.
 - (Access door 2 is not required if enough space is available below the unit for a maintenance worker to work in.)
- (2) When a space of less than 300mm is available below the unit between the unit and the ceiling. (At least 20mm of space should be left below the unit as shown in Fig.3.)
 - Create access door 1 diagonally below the control box and access door 3 below the unit as shown in Fig.4.
 - or
 - Create access door 4 below the control box and the unit as shown in Fig.5.

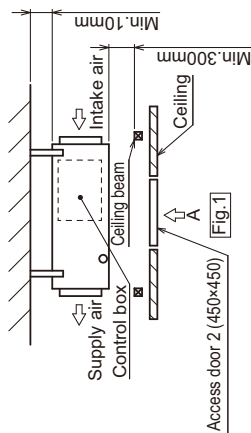

Fig.1 (Viewed from the direction of the arrow A)

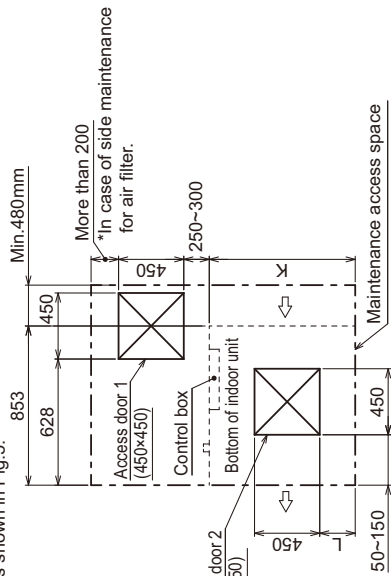

Fig.2 (Viewed from the direction of the arrow A)

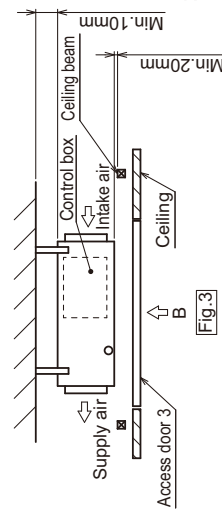

Fig.3

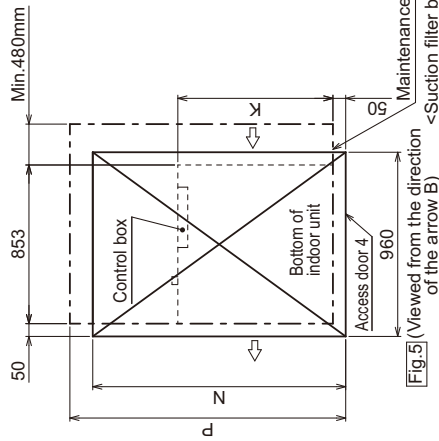

Fig.4 (Viewed from the direction of the arrow B)

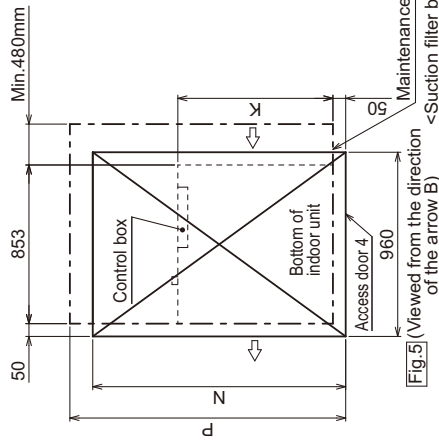

Fig.5 (Viewed from the direction of the arrow B)

* Dimension 'P' is in case of side maintenance for air filter.

Model	K	L	M	N	P*
PEFY-M20, 25, 32VMA-A1	700	50~150	800	1300	1450
PEFY-M40VMA-A1	900	150~250	1000	1500	1850
PEFY-M50, 63VMA-A1	1100	250~350	1200	1700	1700
PEFY-M71, 80, 100, 125VMA-A1	1400	400~500	1500	2000	2150
PEFY-M140VMA-A1	1600	500~600	1700	2200	2550

2. EXTERNAL DIMENSIONS

Ceiling concealed (Medium static pressure type)

PEFY-M20, 25, 32, 40, 50, 63, 71, 80, 100, 125, 140VMAL-A1

Unit: mm

- Note 1. Use M10 screw for the Suspension bolt (field supply).
 2. Keep the service space for the maintenance at the bottom.
 3. This chart indicates for PEFY-M50-63VMAL-A1 models, which have 2 fans. PEFY-M20, 25, 32VMAL-A1 models have 1 fan. PEFY-M40VMAL-A1 models have 2 fans. PEFY-M71, 80, 100, 125, 140VMAL-A1 models have 3 fans.
 4. In case of the inlet duct is used, remove the air filter (supply with the unit), then install the filter (field supply) at suction side.

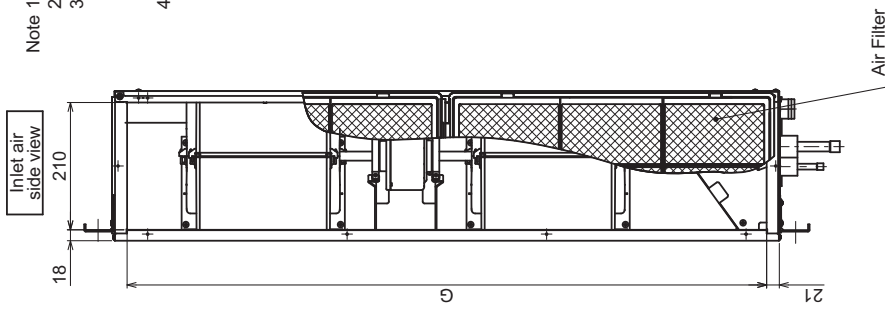
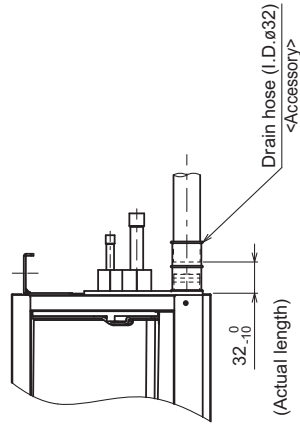

Model	A	B	C	D	E	F	G	① Gas pipe	② Liquid pipe
PEFY-M20, 25, 32VMAL-A1	700	754	800	660	7	600	658		
PEFY-M40VMAL-A1	900	954	1000	860	9	800	858	ø12.7	ø6.35
PEFY-M50VMAL-A1	1100	1154	1200	1060	11	1000	1058		
PEFY-M63VMAL-A1	1100	1154	1200	1060	11	1000	1058		
PEFY-M71, 80, 100, 125VMAL-A1	1400	1454	1500	1360	14	1300	1358	ø15.88	ø9.52
PEFY-M140VMAL-A1	1600	1654	1700	1560	16	1500	1558		

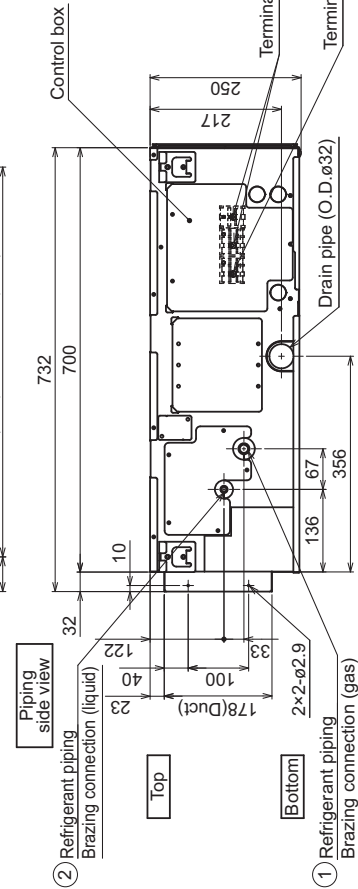
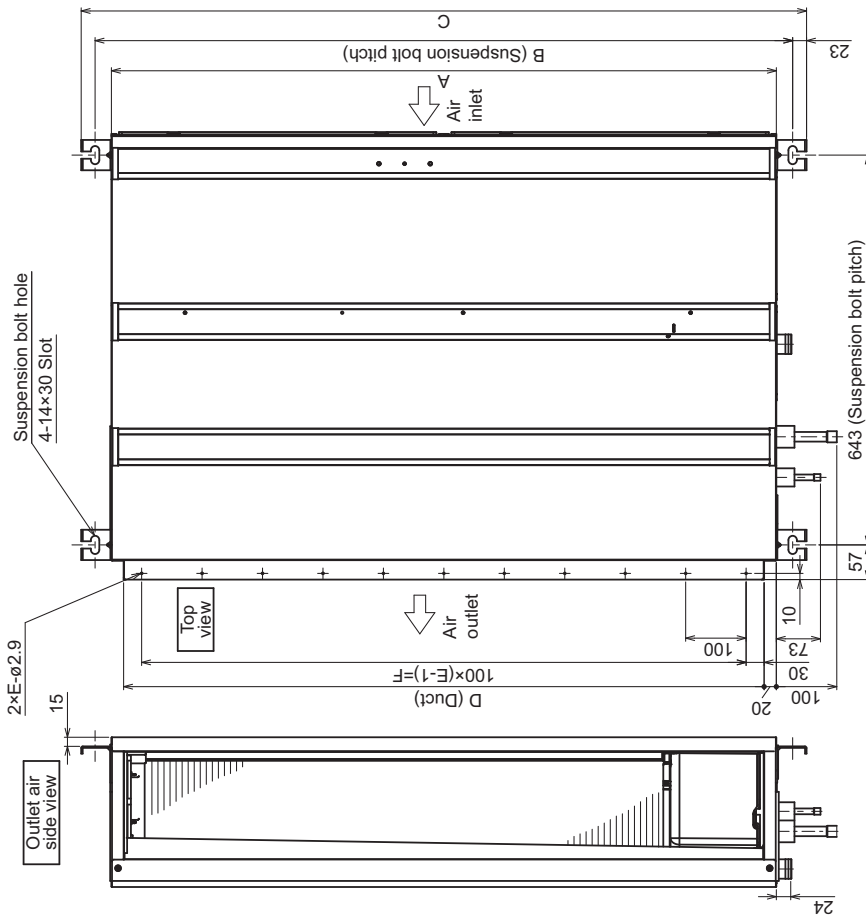

PEFY-M20, 25, 32, 40, 50, 63, 71, 80, 100, 125, 140VMAL-A1

Unit: mm

[Maintenance access space]
 Secure enough access space to allow for the maintenance, inspection, and replacement of the motor, fan, heat exchanger, and control box in one of the following ways.
 Select an installation site for the indoor unit so that its maintenance access space will not be obstructed by beams or other objects.
 (1) When a space of 300mm or more is available below the unit between the unit and the ceiling. (Fig. 1)
 · Create access door 1 and 2 (450×450mm each) as shown in Fig. 2.
 (Access door 2 is not required if enough space is available below the unit for a maintenance worker to work in.)

(2) When a space of less than 300mm is available below the unit between the unit and the ceiling.
 (At least 20mm of space should be left below the unit as shown in Fig. 3.)
 · Create access door 1 diagonally below the control box and access door 3 below the unit as shown in Fig. 4.
 or
 · Create access door 4 below the control box and the unit as shown in Fig. 5.

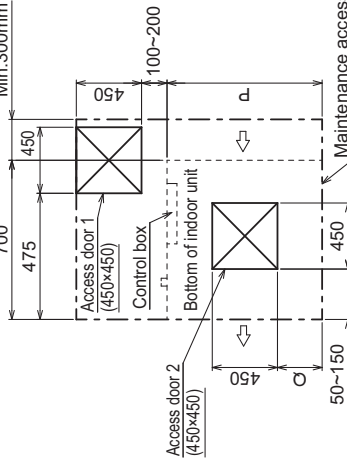
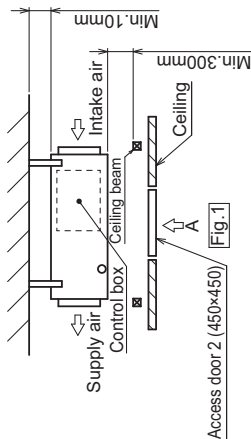

Fig. 2 (Viewed from the direction of the arrow A)

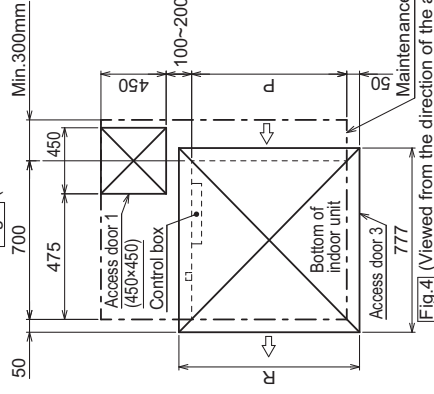

Fig. 4 (Viewed from the direction of the arrow B)

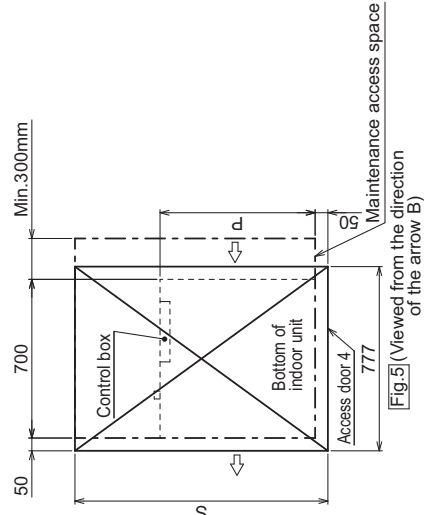
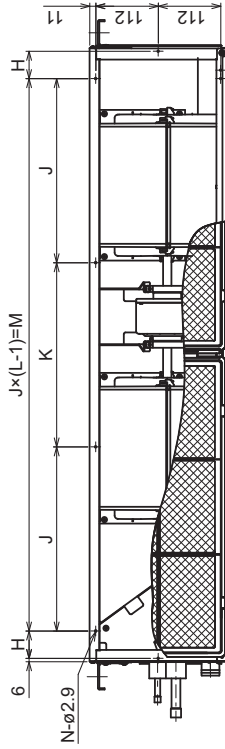

Fig. 5 (Viewed from the direction of the arrow B)

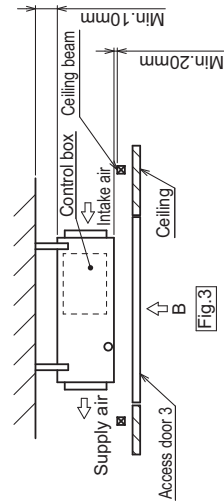

Fig. 3

Model	H	J	K	L	M	N	P	Q	R	S
PEFY-M20, 25, 32VMAL-A1	44	150	300			10	700	50~150	800	1300
PEFY-M40VMAL-A1	54	260	4	780	10	900	150~250	1000	1500	1500
PEFY-M60, 63VMAL-A1	49	330	4	990	10	1100	250~350	1200	1700	1700
PEFY-M71, 80, 100, 125VMAL-A1	54	320	5	1280	12	1400	400~500	1500	2000	2000
PEFY-M140VMAL-A1	54	370	5	1480	12	1600	500~600	1700	2200	2200

PEFY-M20, 25, 32, 40, 50, 63, 71, 80, 100, 125, 140VMA-L-A1 Suction filter box built-in-specification

Unit: mm

- Note 1. Use M10 screw for the Suspension bolt (field supply).
 2. Keep the service space for the maintenance at the bottom.
 3. This chart indicates for PEFY-M50-63VMA-L-A1 models, which have 2 fans. PEFY-M20-25-32VMA-L-A1 models have 1 fan. PEFY-M40VMA-L-A1 models have 2 fans.
 PEFY-M71-80-100-125-140VMA-L-A1 models have 3 fans.
 4. Use air filter installed with indoor unit.

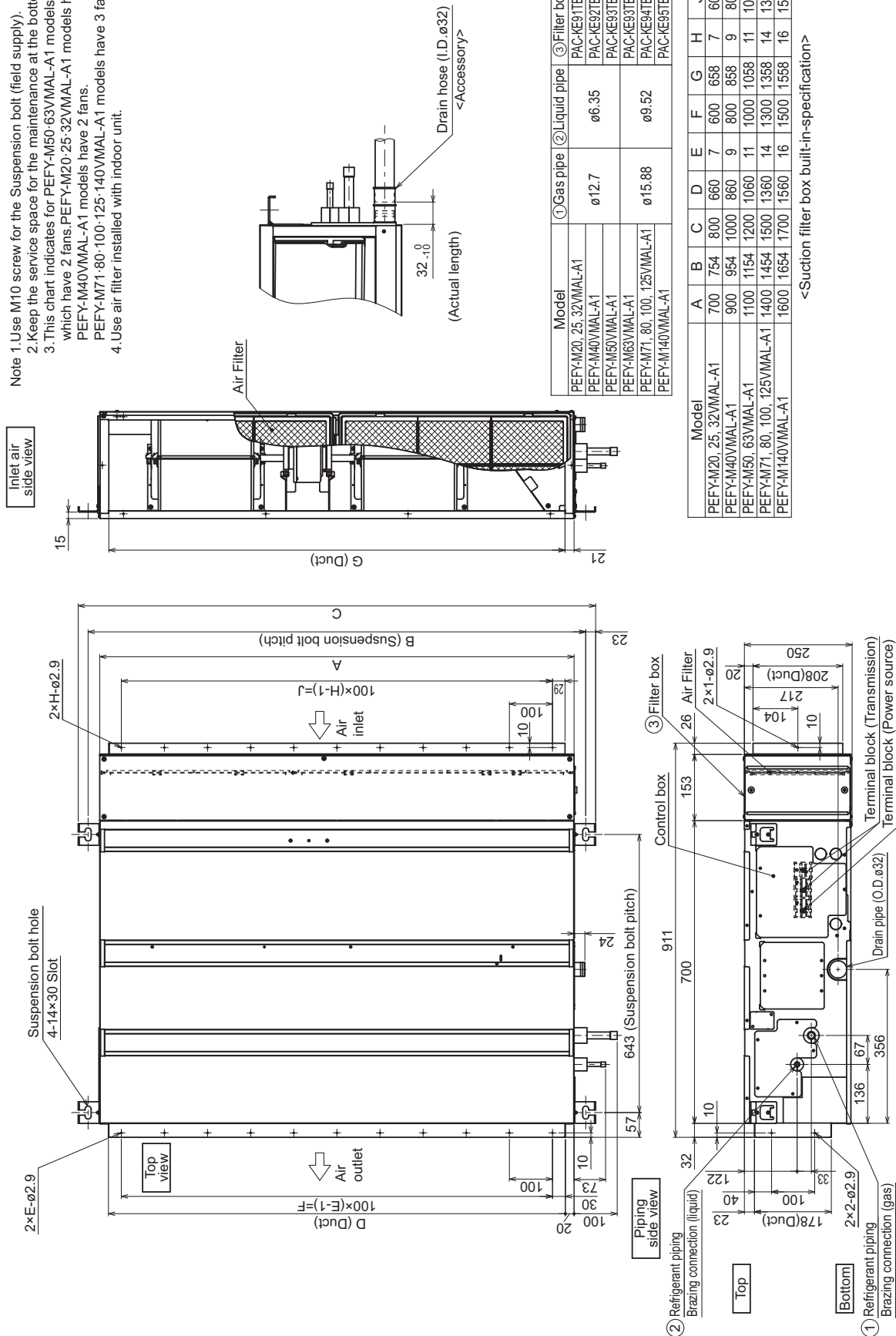

PEFY-M20, 25, 32, 40, 50, 63, 71, 80, 100, 125, 140VMAL-A1 Suction filter box built-in-specification

Unit: mm

[Maintenance access space]
Secure enough access space to allow for the maintenance, inspection, and replacement of the motor, fan, heat exchanger, and control box in one of the following ways.
Select an installation site for the indoor unit so that its maintenance access space will not be obstructed by beams or other objects.

- (1) When a space of 300mm or more is available below the unit between the unit and the ceiling. (Fig. 1)
 - Create access door 1 and 2 (450×450mm each) as shown in Fig. 2.
 - (Access door 2 is not required if enough space is available below the unit for a maintenance worker to work in.)
- (2) When a space of less than 300mm is available below the unit between the unit and the ceiling. (At least 20mm of space should be left below the unit as shown in Fig. 3.)
 - Create access door 1 diagonally below the control box and access door 3 below the unit as shown in Fig. 4.
 - or
 - Create access door 4 below the control box and the unit as shown in Fig. 5.

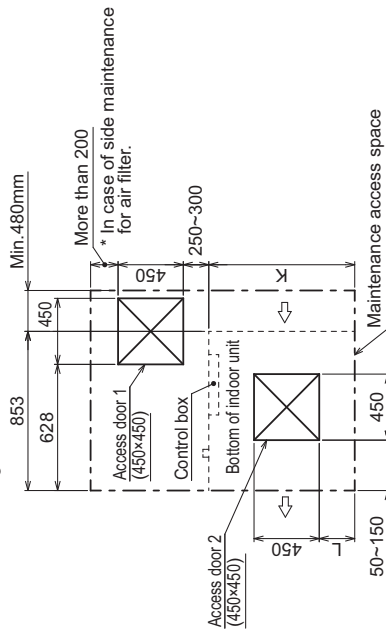
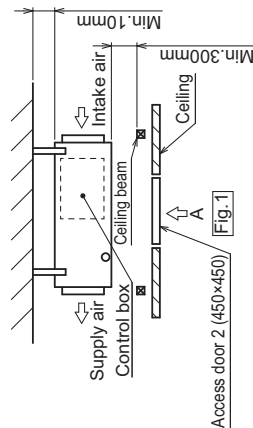

Fig. 2 (Viewed from the direction of the arrow A)

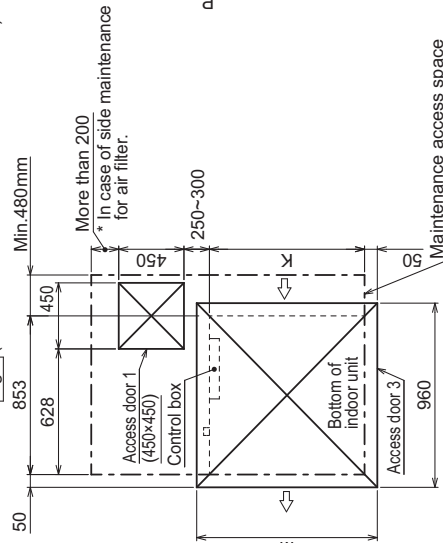

Fig. 4 (Viewed from the direction of the arrow B)

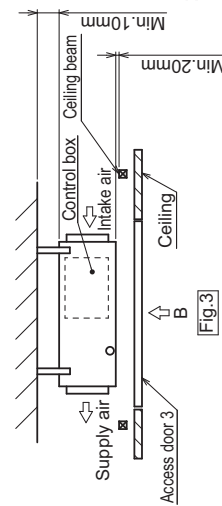

Fig. 3

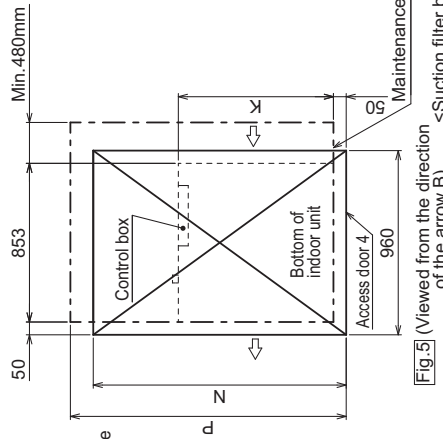

Fig. 5 (Viewed from the direction of the arrow B) <Suction filter box built-in-specification>

* Dimension 'P' is in case of side maintenance for air filter.

Model	K	L	M	N	P*
PEFY-M20, 25, 32/VMAL-A1	700	50~150	800	1300	1450
PEFY-M40/VMAL-A1	900	150~250	1000	1500	1850
PEFY-M50, 63/VMAL-A1	1100	250~350	1200	1700	2150
PEFY-M71, 80, 100, 125/VMAL-A1	1400	400~500	1500	2000	2550
PEFY-M140/VMAL-A1	1600	500~600	1700	2200	2550

PEFY-M20, 25, 32, 40, 50, 63, 71, 80, 100, 125, 140VMA(L)-A1

PEFY-M-VMA(L)-A1

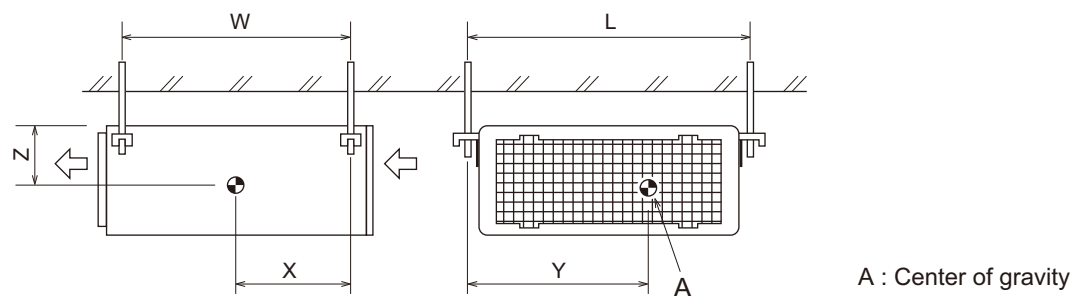

(mm) [in]

Model name	W	L	X	Y	Z
PEFY-M20VMA(L)-A1	643 [25 - 6/16]	754 [29 - 11/16]	330 [13]	300 [11 - 13/16]	130 [5 - 2/16]
PEFY-M25VMA(L)-A1	643 [25 - 6/16]	754 [29 - 11/16]	330 [13]	300 [11 - 13/16]	130 [5 - 2/16]
PEFY-M32VMA(L)-A1	643 [25 - 6/16]	754 [29 - 11/16]	330 [13]	300 [11 - 13/16]	130 [5 - 2/16]
PEFY-M40VMA(L)-A1	643 [25 - 6/16]	954 [37 - 9/16]	340 [13 - 7/16]	375 [14 - 13/16]	130 [5 - 2/16]
PEFY-M50VMA(L)-A1	643 [25 - 6/16]	1154 [45 - 7/16]	325 [12 - 13/16]	525 [20 - 11/16]	130 [5 - 2/16]
PEFY-M63VMA(L)-A1	643 [25 - 6/16]	1154 [45 - 7/16]	325 [12 - 13/16]	525 [20 - 11/16]	130 [5 - 2/16]
PEFY-M71VMA(L)-A1	643 [25 - 6/16]	1454 [57 - 4/16]	330 [13]	675 [26 - 10/16]	130 [5 - 2/16]
PEFY-M80VMA(L)-A1	643 [25 - 6/16]	1454 [57 - 4/16]	330 [13]	675 [26 - 10/16]	130 [5 - 2/16]
PEFY-M100VMA(L)-A1	643 [25 - 6/16]	1454 [57 - 4/16]	330 [13]	675 [26 - 10/16]	130 [5 - 2/16]
PEFY-M125VMA(L)-A1	643 [25 - 6/16]	1454 [57 - 4/16]	330 [13]	675 [26 - 10/16]	130 [5 - 2/16]
PEFY-M140VMA(L)-A1	643 [25 - 6/16]	1654 [65 - 2/16]	332 [13 - 2/16]	725 [28 - 9/16]	130 [5 - 2/16]

PEFY-M20, 25, 32, 40, 50, 63, 71, 80, 100, 125, 140VMA(L)-A1

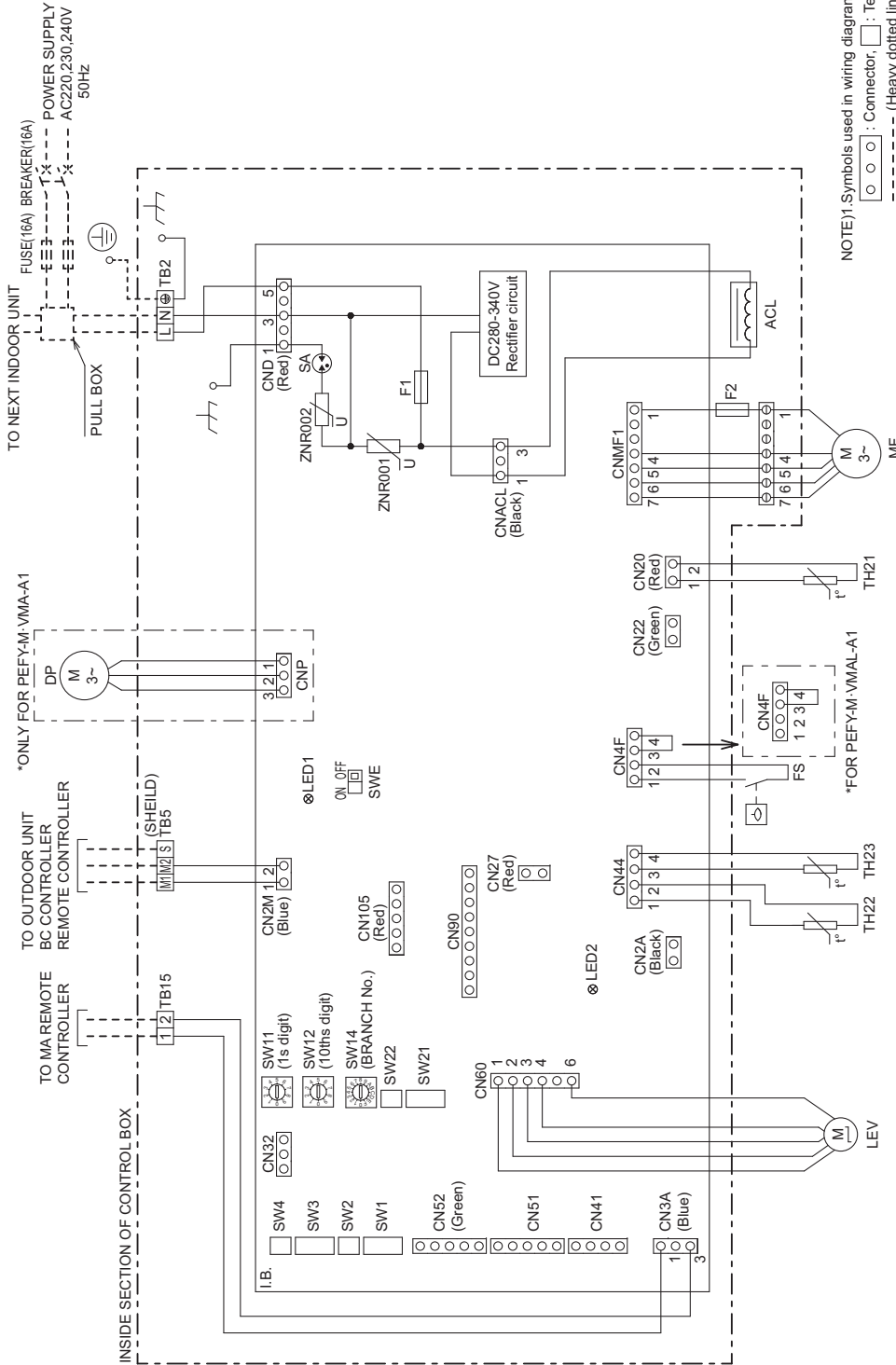

NOTE1: Symbols used in wiring diagram are
 ○○○○ : Connector; □ : Terminal;
 --- (Heavy dotted line): Field wiring,
 according to the local regulations.

2. Have all electric work done by a licensed electrician of the power supply.
 3. Earth leakage circuit breaker should be set up on the wiring on the control board while the indoor unit is being powered.
 4. To perform a drainage test for the drain pump turn on the SWE
- *Be sure to turn off the SWE after completing a drainage test or test run.

SYMBOL EXPLANATION

SYMBOL	NAME	SYMBOL	NAME	SYMBOL	NAME
ACL	AC reactor(Power factor improvement)	I.B.	Indoor controller board	SW1	Indoor controller board
DP	Drain Pump	SA	Arrester	SW2	Switch (for mode selection)
F2	Fuse DC400V 3A	F1	Fuse AC250V 6.3A	SW3	Switch (for capacity code)
FS	Float switch	ZNR001,002	Varistor	SW4	Switch (for model selection)
MIF	Fan Motor	CN2A	Connector (0-10V Analog input)	SW11	Switch (1s digit address set)
LEV	Linear expansion valve	CN22	Connector (Optional Thermistor)	SW12	Switch (10ths digit address set)
TB2	Power source terminal block	CN27	Connector (Damper)	SW14	Switch (BRANCH No.)
TB5	Transmission terminal block	CN41	Connector (Remote switch)	SW21	Switch (for static pressure selection)
TB15	Transmission terminal block	CN44	Connector (HA terminal-A)	SW22	Switch (Wireless pair No.)
TH21	Thermistor (inlet air temp. detection)	CN51	Connector (Centrally control)	SWE	Connector (emergency operation)
TH22	Thermistor (piping temp.detection/liquid)	CN52	Connector (Remote indication)	LED1	LED(Power supply)
TH23	Thermistor (piping temp.detection/gas)	CN90	Connector (Wireless)	LED2	LED(Remote controller supply)
		CN105	Connector (IT terminal)		

5-1. Sound levels

PEFY-M-VMA(L)-A1

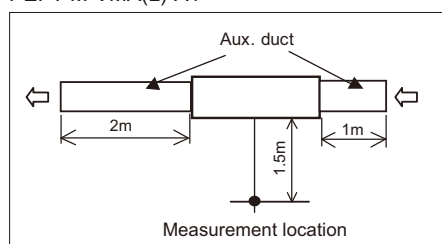

* Measured in anechoic room.

Sound level at anechoic room: Low-Mid2-Mid1-High

Model		Sound level dB (A)					
		35Pa	40Pa	50Pa	70Pa	100Pa	150Pa
PEFY-M20, 25VMA(L)-A1	Cooling	21.5-23-26.5-30	-	21.5-24.5-27.5-30.5	23.5-25-29-31	23-26-30-34	28.5-32.5-35.5-38.5
	Heating	21.5-23-26.5-30	-	21.5-24.5-27.5-30.5	23.5-25-29-31	23-26-30-34	28.5-32.5-35.5-38.5
PEFY-M32VMA(L)-A1	Cooling	24.0-28.0-31.5-35.5	-	26.5-29.0-32.5-36.5	25.5-30.0-33.5-37.5	27.0-31.5-34.5-38.5	32.0-34.5-37.0-39.0
	Heating	24.0-28.0-31.5-35.5	-	26.5-29.0-32.5-36.5	25.5-30.0-33.5-37.5	27.0-31.5-34.5-38.5	32.0-34.5-37.0-39.0
PEFY-M40VMA(L)-A1	Cooling	23.5-25.5-28.5-37	-	23-26-29-37.5	24-27-32-39	26-30.5-33.5-39.5	33-36.5-38.5-41
	Heating	23.5-25.5-28.5-37	-	23-26-29-37.5	24-27-32-39	26-30.5-33.5-39.5	33-36.5-38.5-41
PEFY-M50VMA(L)-A1	Cooling	22-24-26.5-37	-	22.5-24.5-27.5-37.5	22.5-25.5-28-38.5	22.5-26.5-29.5-40	31.5-34.5-37.5-40.5
	Heating	22-24-26.5-37	-	22.5-24.5-27.5-37.5	22.5-25.5-28-38.5	22.5-26.5-29.5-40	31.5-34.5-37.5-40.5
PEFY-M63VMA(L)-A1	Cooling	23-26-30-37.5	-	23-26.5-31-38	24-28.5-31.5-39	24.5-28.5-32.5-40	31.5-35-38-41
	Heating	23-26-30-41.5	-	23-26.5-31-41	24-28.5-31.5-40.5	24.5-28.5-32.5-41	31.5-35-38-41
PEFY-M71, 80VMA(L)-A1	Cooling	-	22-25-27.5-38.5	21.5-25-28.5-39	22.5-26-29.5-40.5	23-27.5-31-42.5	33-36.5-40-42
	Heating	-	22-25-27.5-40.5	21.5-25-28.5-41.5	22.5-26-29.5-42.5	23-27.5-31-43	33-36.5-40-42
PEFY-M100VMA(L)-A1	Cooling	-	29.5-34-37.5-40	29.5-34.5-37.5-41	31-35.5-38.5-42	32.5-37-40-43	36.5-39.5-43-45.5
	Heating	-	29.5-34-37.5-40	29.5-34.5-37.5-41	31-35.5-38.5-42	32.5-37-40-43	36.5-39.5-43-45.5
PEFY-M125VMA(L)-A1	Cooling	-	31-36-38.5-40.5	31.5-36.5-38.5-40.5	34-37.5-39.5-42	34.5-39-41.5-43	37-40.5-44-46.5
	Heating	-	31-36-38.5-40.5	31.5-36.5-38.5-40.5	34-37.5-39.5-42	34.5-39-41.5-43	37-40.5-44-46.5
PEFY-M140VMA(L)-A1	Cooling	-	33.5-37.5-40.5-42.5	34-38-40.5-43	34.5-39-41-43.5	35.5-39.5-42.5-45	39.5-42-45-47
	Heating	-	33.5-37.5-40.5-42.5	34-38-40.5-43	34.5-39-41-43.5	35.5-39.5-42.5-45	39.5-42-45-47

5-2. NC curves

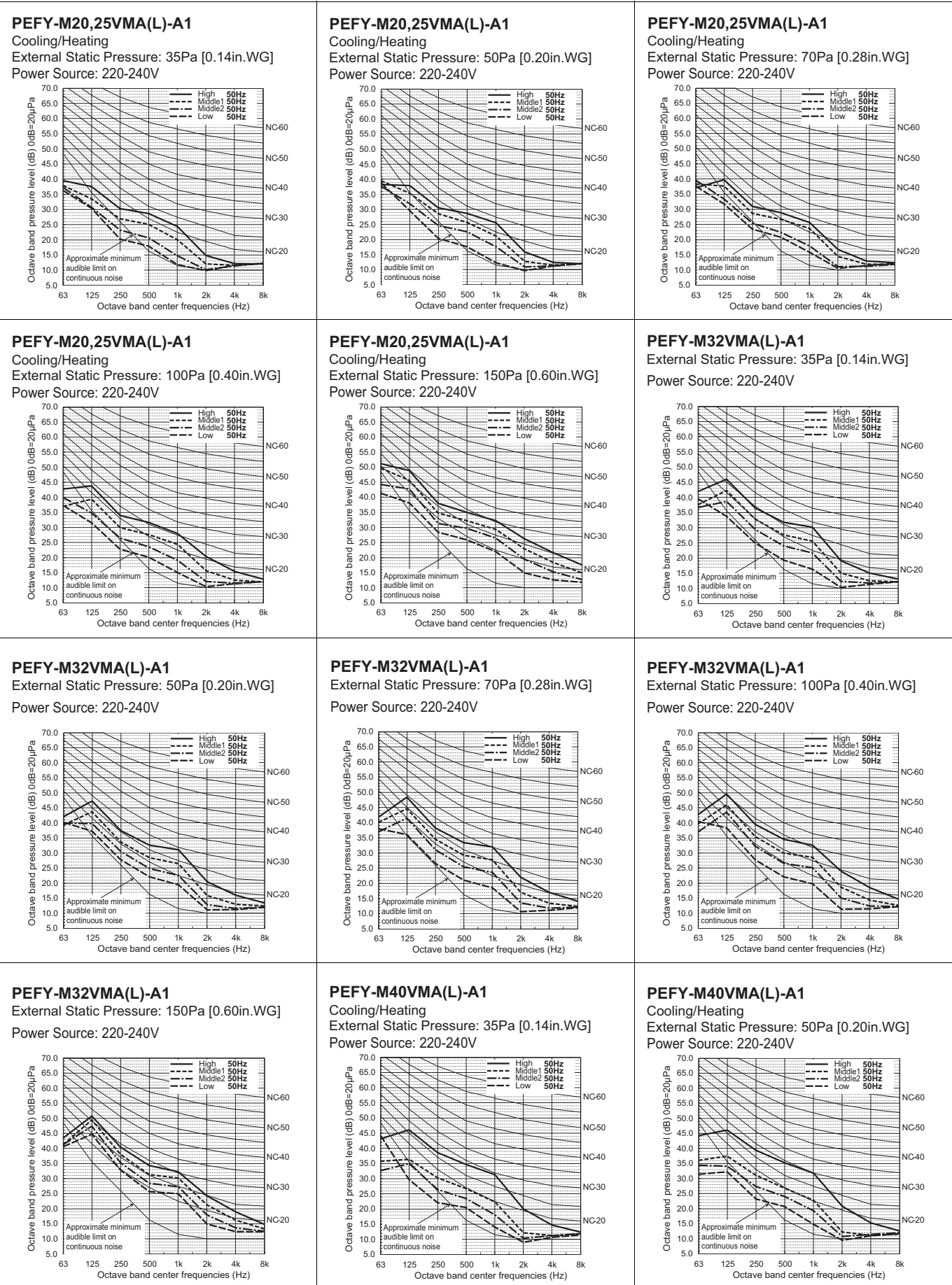

PEFY-M-VMA(L)-A1

PEFY-M40VMA(L)-A1

Cooling/Heating
External Static Pressure: 70Pa [0.28in.WG]
Power Source: 220-240V

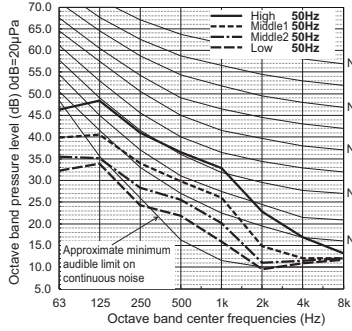

PEFY-M40VMA(L)-A1

Cooling/Heating
External Static Pressure: 100Pa [0.40in.WG]
Power Source: 220-240V

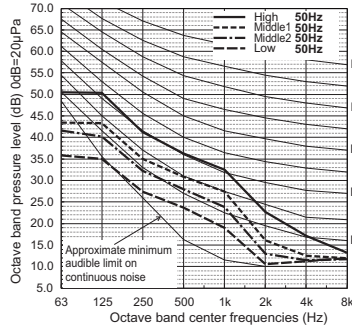

PEFY-M40VMA(L)-A1

Cooling/Heating
External Static Pressure: 150Pa [0.60in.WG]
Power Source: 220-240V

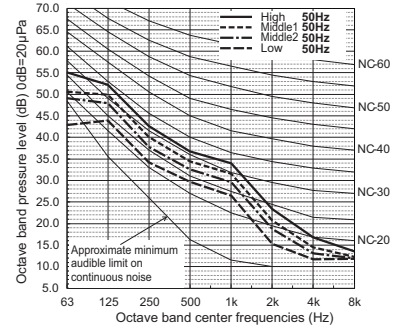

PEFY-M50VMA(L)-A1

Cooling/Heating
External Static Pressure: 35Pa [0.14in.WG]
Power Source: 220-240V

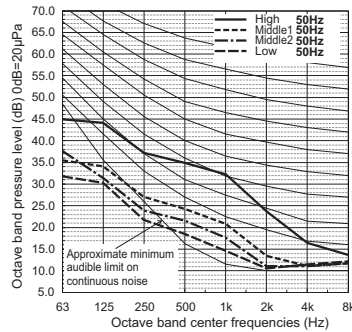

PEFY-M50VMA(L)-A1

Cooling/Heating
External Static Pressure: 50Pa [0.20in.WG]
Power Source: 220-240V

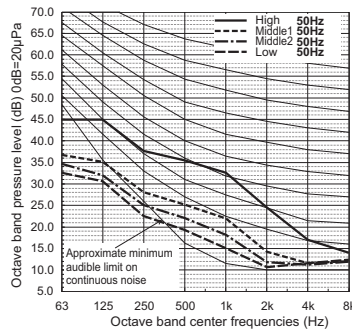

PEFY-M50VMA(L)-A1

Cooling/Heating
External Static Pressure: 70Pa [0.28in.WG]
Power Source: 220-240V

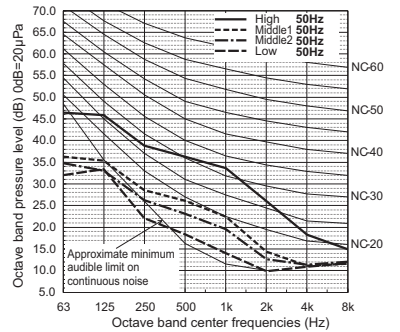

PEFY-M50VMA(L)-A1

Cooling/Heating
External Static Pressure: 100Pa [0.40in.WG]
Power Source: 220-240V

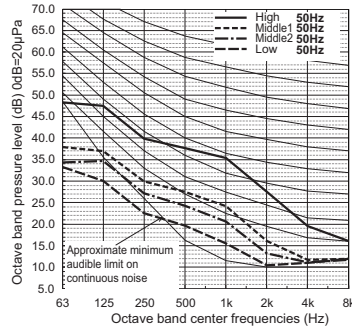

PEFY-M50VMA(L)-A1

Cooling/Heating
External Static Pressure: 150Pa [0.60in.WG]
Power Source: 220-240V

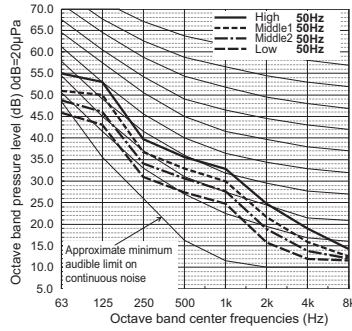

PEFY-M63VMA(L)-A1

Cooling
External Static Pressure: 35Pa [0.14in.WG]
Power Source: 220-240V

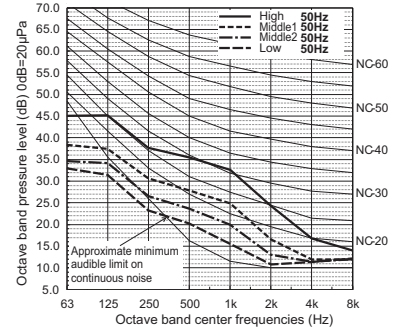

PEFY-M63VMA(L)-A1

Heating
External Static Pressure: 35Pa [0.14in.WG]
Power Source: 220-240V

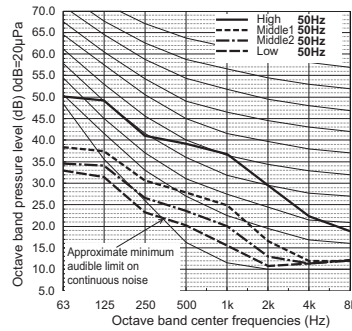

PEFY-M63VMA(L)-A1

Cooling
External Static Pressure: 50Pa [0.20in.WG]
Power Source: 220-240V

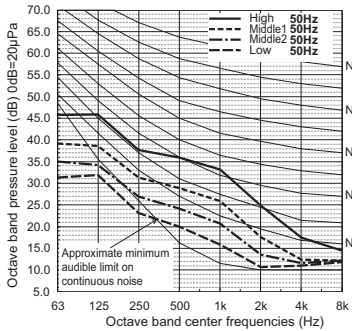

PEFY-M63VMA(L)-A1

Heating
External Static Pressure: 50Pa [0.20in.WG]
Power Source: 220-240V

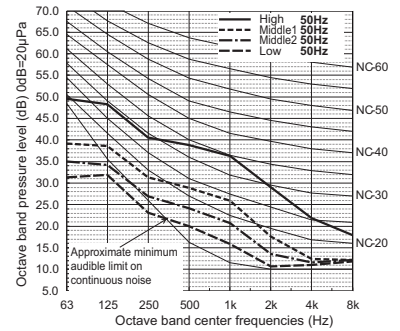

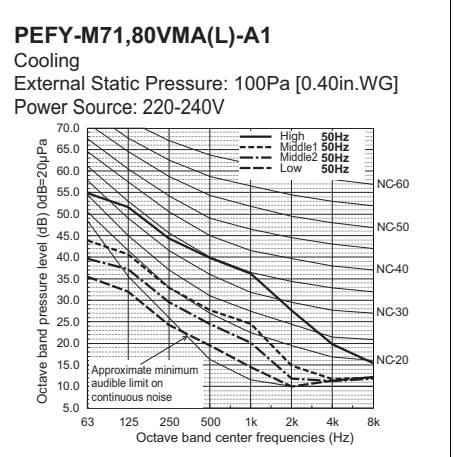
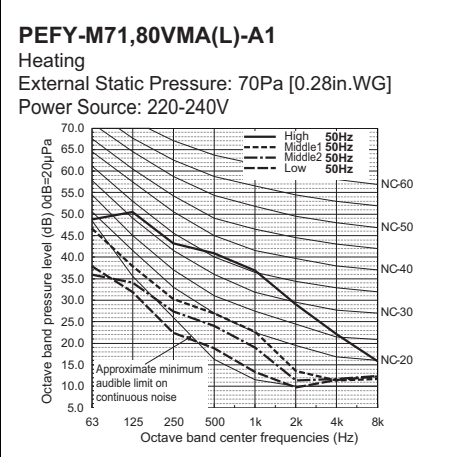
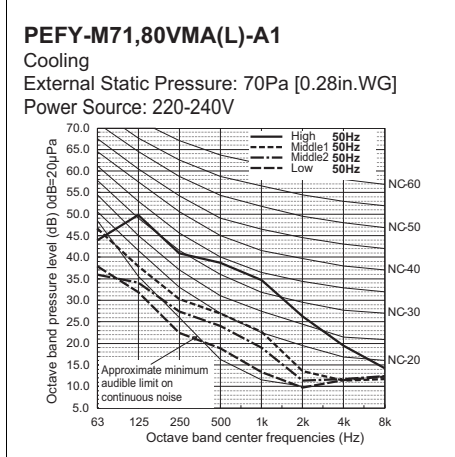
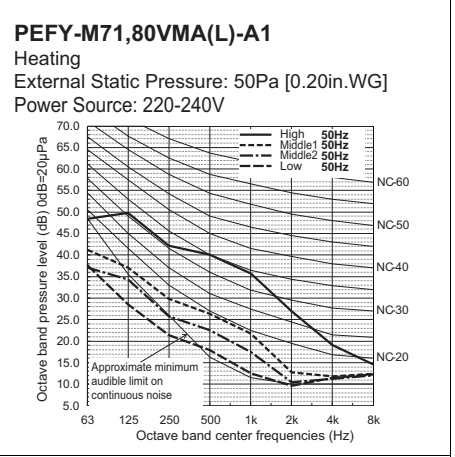
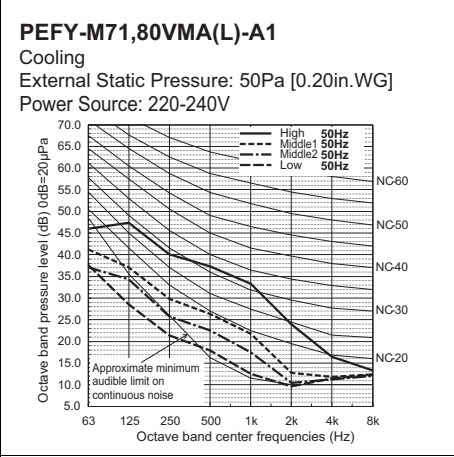
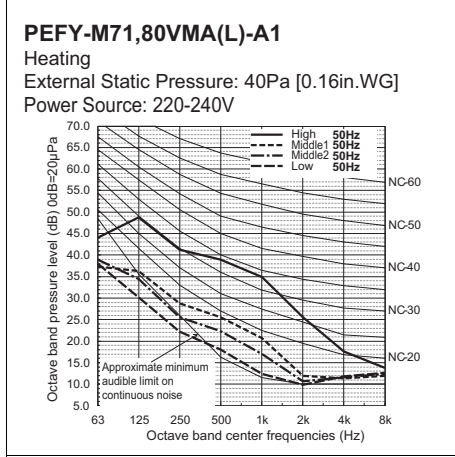
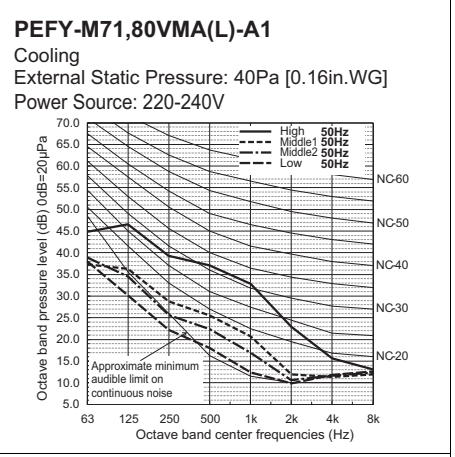
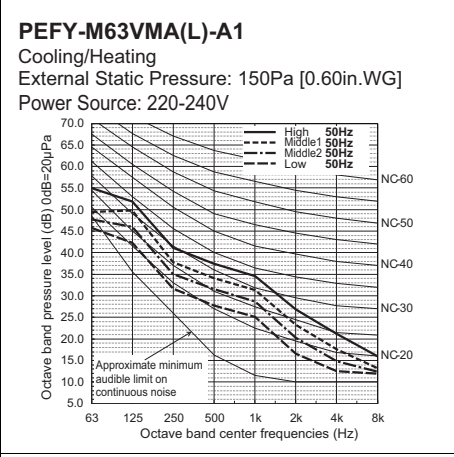
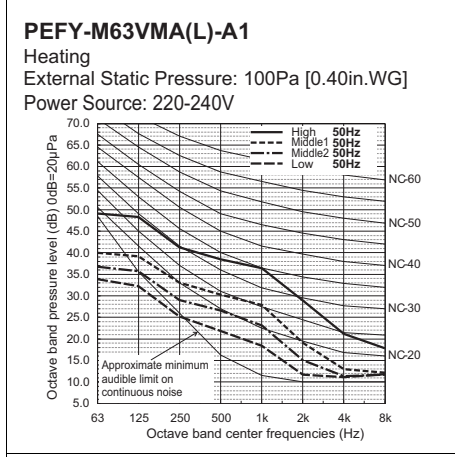
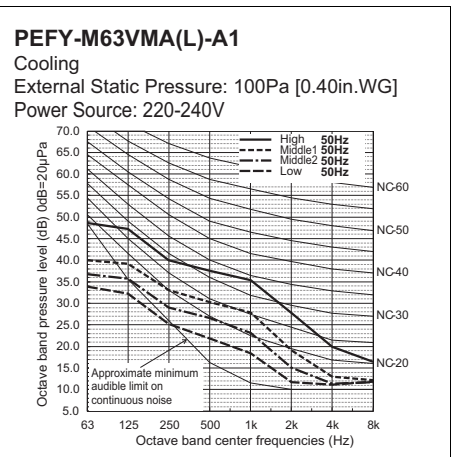
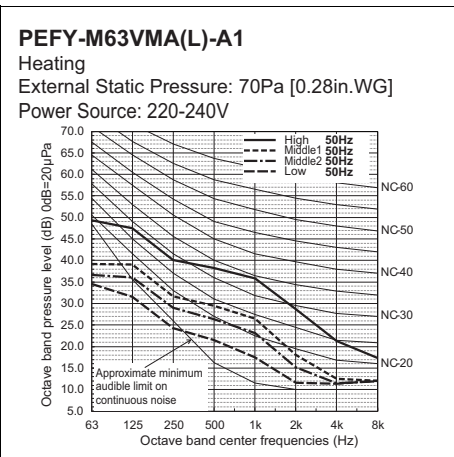
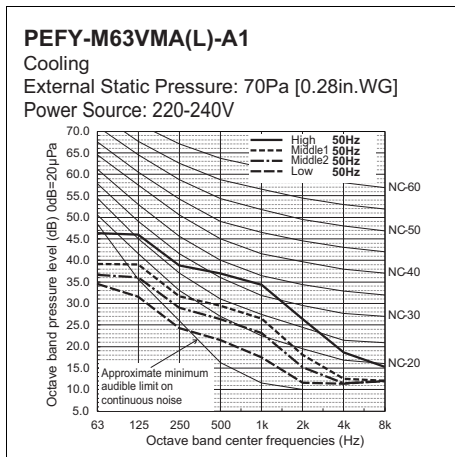

PEFY-M-VMA(L)-A1

PEFY-M71,80VMA(L)-A1

Heating
External Static Pressure: 100Pa [0.40in.WG]
Power Source: 220-240V

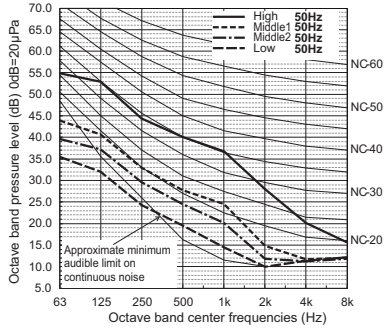

PEFY-M71,80VMA(L)-A1

Cooling/Heating
External Static Pressure: 150Pa [0.60in.WG]
Power Source: 220-240V

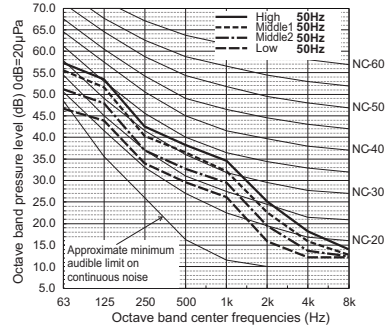

PEFY-M100VMA(L)-A1

Cooling/Heating
External Static Pressure: 40Pa [0.16in.WG]
Power Source: 220-240V

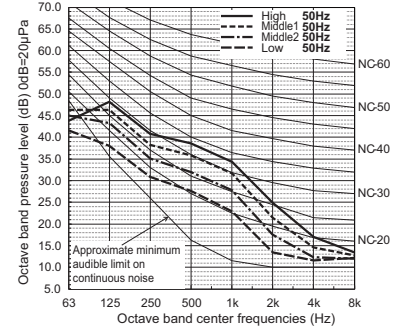

PEFY-M100VMA(L)-A1

Cooling/Heating
External Static Pressure: 50Pa [0.20in.WG]
Power Source: 220-240V

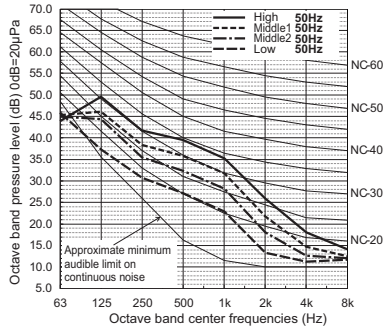

PEFY-M100VMA(L)-A1

Cooling/Heating
External Static Pressure: 70Pa [0.28in.WG]
Power Source: 220-240V

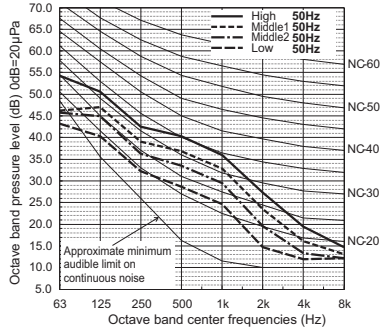

PEFY-M100VMA(L)-A1

Cooling/Heating
External Static Pressure: 100Pa [0.40in.WG]
Power Source: 220-240V

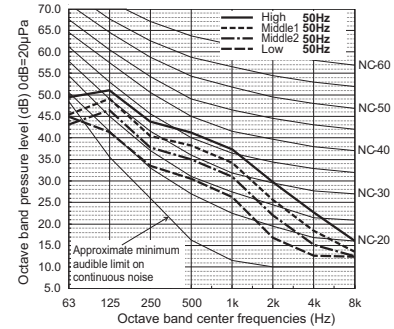

PEFY-M100VMA(L)-A1

Cooling/Heating
External Static Pressure: 150Pa [0.60in.WG]
Power Source: 220-240V

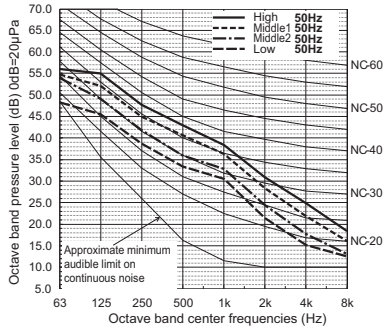

PEFY-M125VMA(L)-A1

Cooling/Heating
External Static Pressure: 40Pa [0.16in.WG]
Power Source: 220-240V

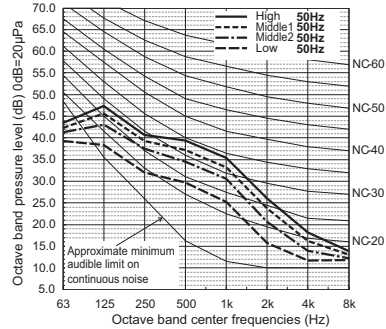

PEFY-M125VMA(L)-A1

Cooling/Heating
External Static Pressure: 50Pa [0.20in.WG]
Power Source: 220-240V

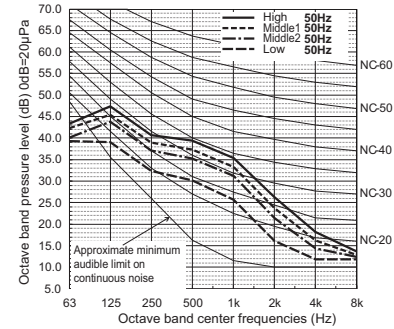

PEFY-M125VMA(L)-A1

Cooling/Heating
External Static Pressure: 70Pa [0.28in.WG]
Power Source: 220-240V

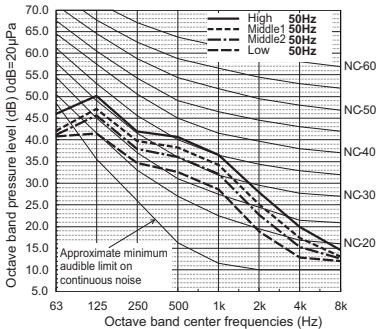

PEFY-M125VMA(L)-A1

Cooling/Heating
External Static Pressure: 100Pa [0.40in.WG]
Power Source: 220-240V

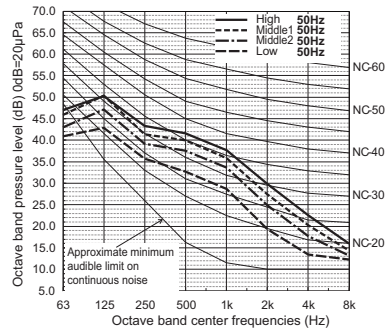

PEFY-M125VMA(L)-A1

Cooling/Heating
External Static Pressure: 150Pa [0.60in.WG]
Power Source: 220-240V

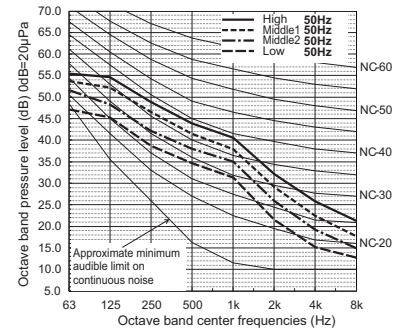

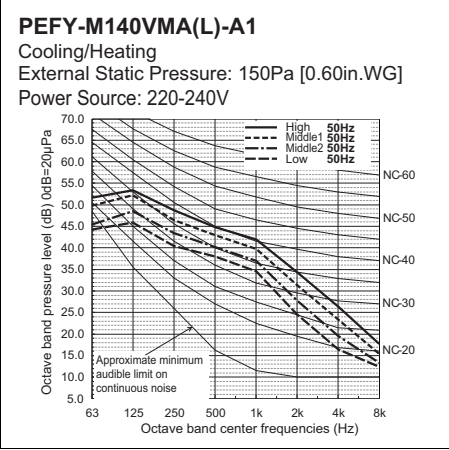
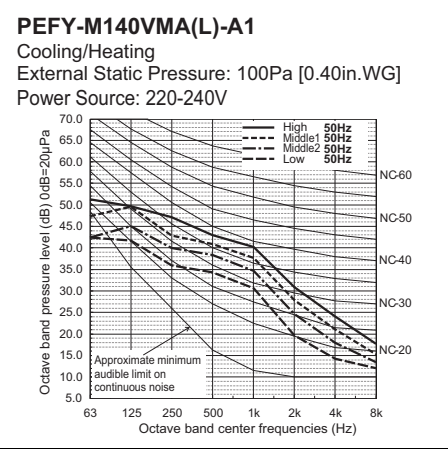
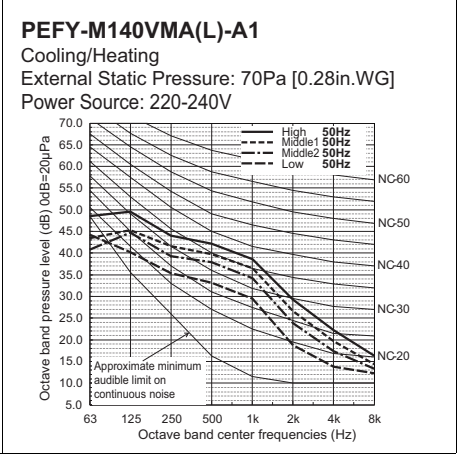
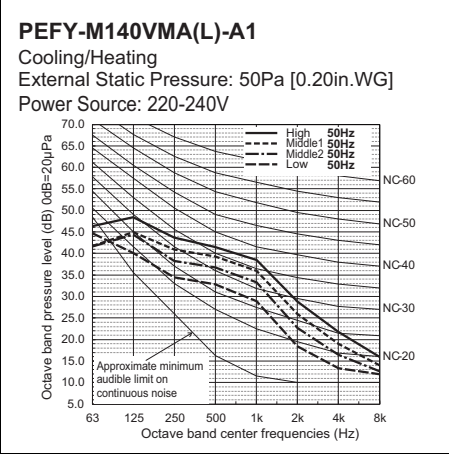
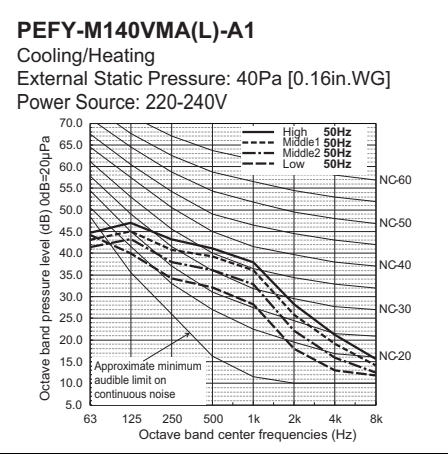

PEFY-M-VMA(L)-A1

PEFY-M-VMA(L)-A1

PEFY-M20, 25VMA(L)-A1
 External static pressure : 35Pa
 Power source : 220-240V

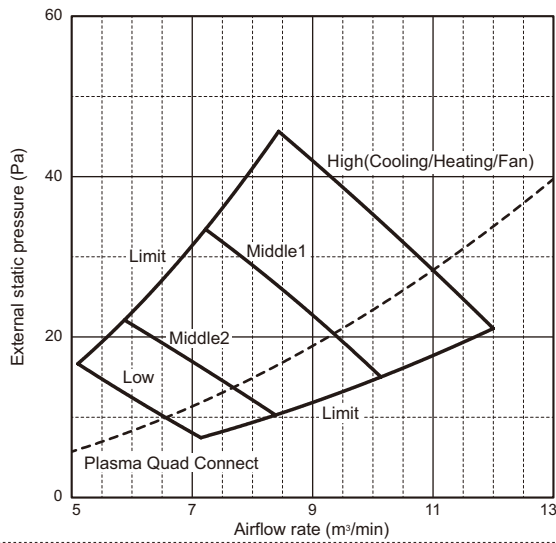

PEFY-M20, 25VMA(L)-A1
 External static pressure : 50Pa
 Power source : 220-240V

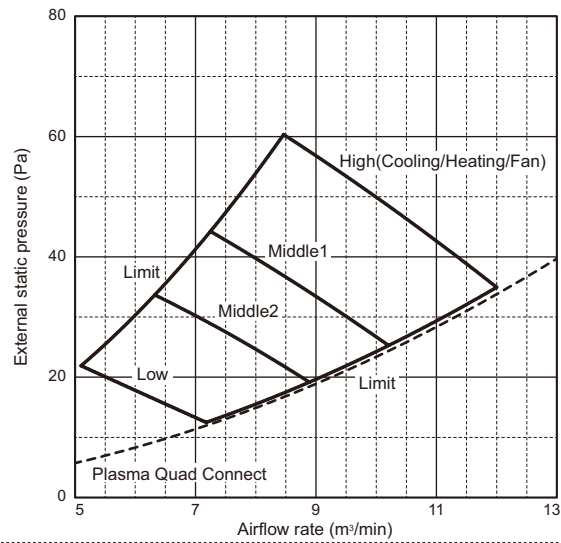

PEFY-M20, 25VMA(L)-A1
 External static pressure : 70Pa
 Power source : 220-240V

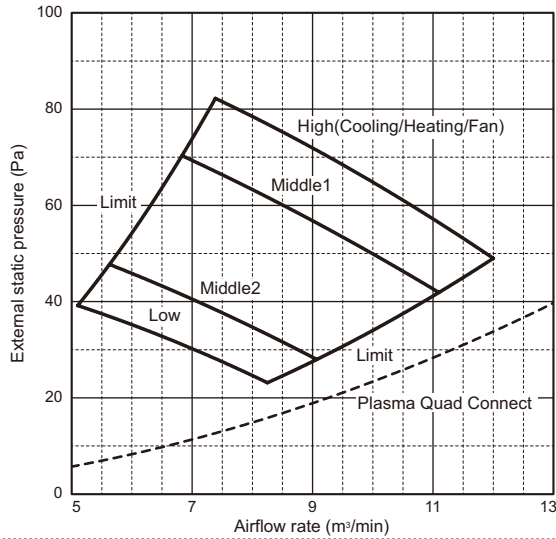

PEFY-M20, 25VMA(L)-A1
 External static pressure : 100Pa
 Power source : 220-240V

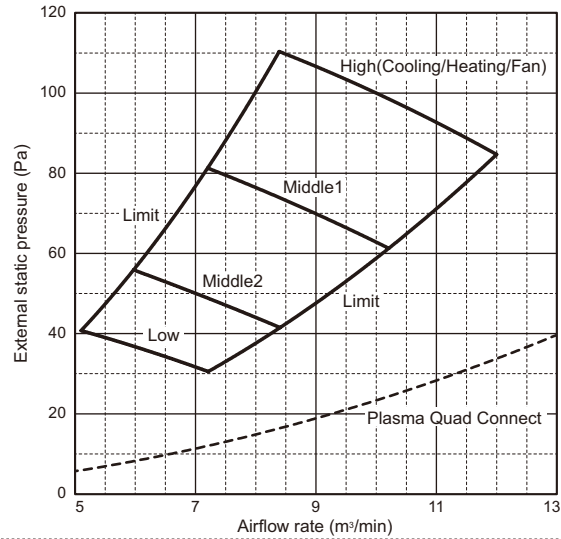

PEFY-M20, 25VMA(L)-A1
 External static pressure : 150Pa
 Power source : 220-240V

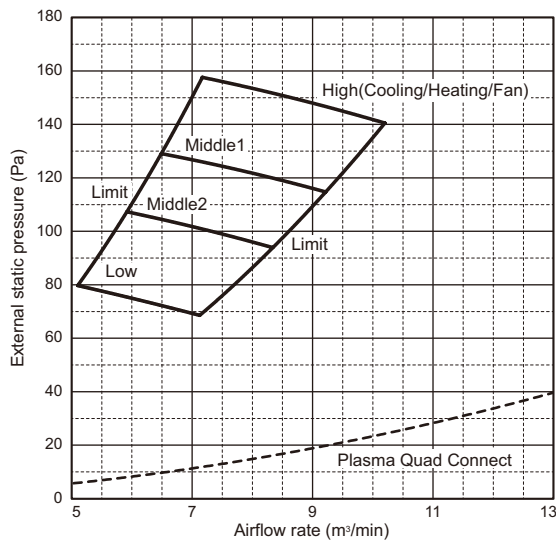

♦The fan characteristic curves (solid line) are the data with no optional parts attached.

PEFY-M32VMA(L)-A1

External static pressure : 35Pa
Power source : 220-240V

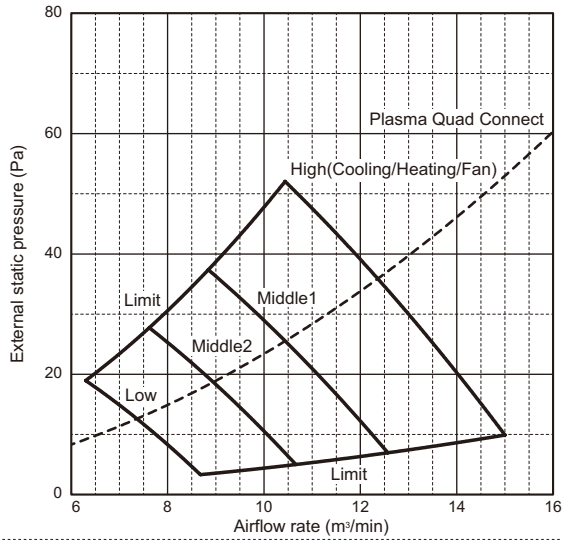

PEFY-M32VMA(L)-A1

External static pressure : 50Pa
Power source : 220-240V

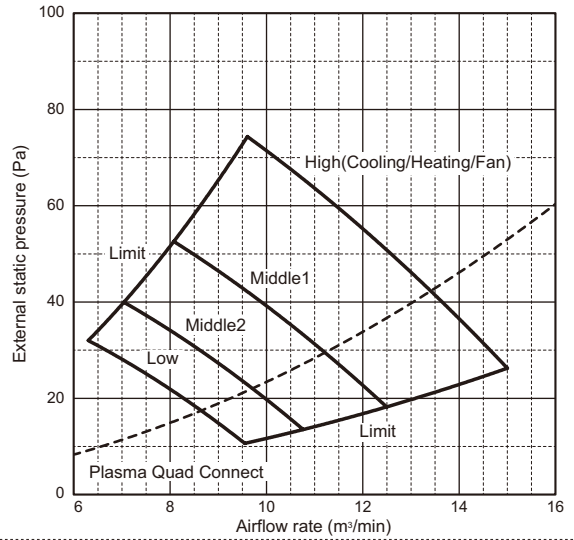

PEFY-M32VMA(L)-A1

External static pressure : 70Pa
Power source : 220-240V

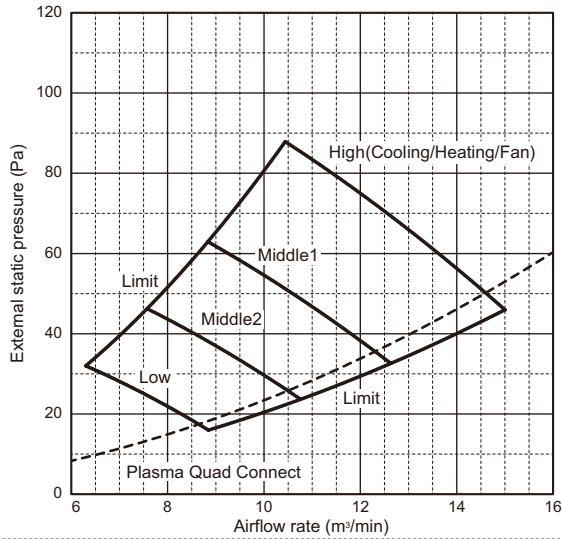

PEFY-M32VMA(L)-A1

External static pressure : 100Pa
Power source : 220-240V

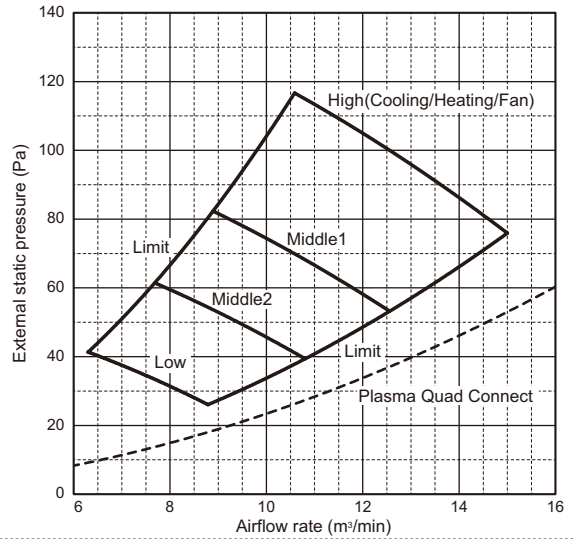

PEFY-M32VMA(L)-A1

External static pressure : 150Pa
Power source : 220-240V

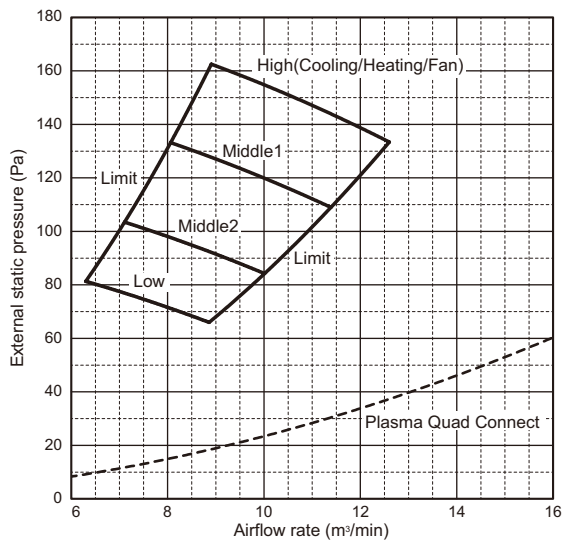

♦The fan characteristic curves (solid line) are the data with no optional parts attached.

PEFY-M-VMA(L)-A1

PEFY-M40VMA(L)-A1
 External static pressure : 35Pa
 Power source : 220-240V

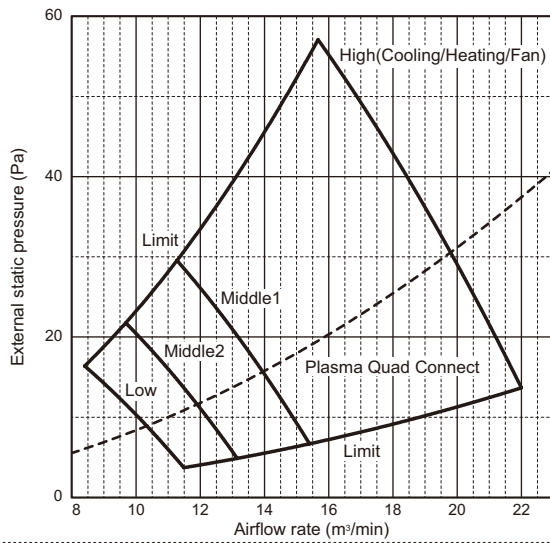

PEFY-M40VMA(L)-A1
 External static pressure : 50Pa
 Power source : 220-240V

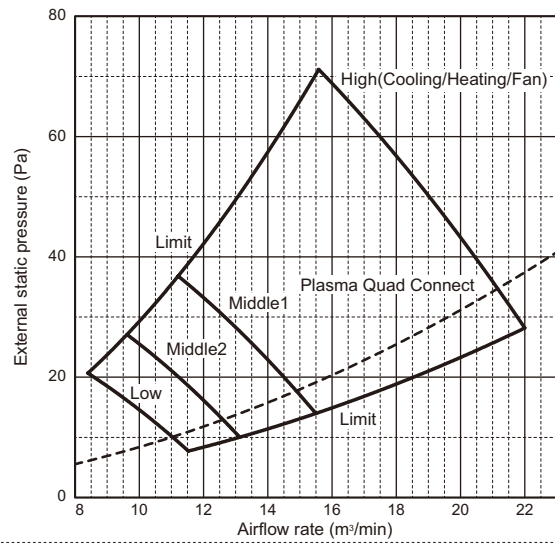

PEFY-M40VMA(L)-A1
 External static pressure : 70Pa
 Power source : 220-240V

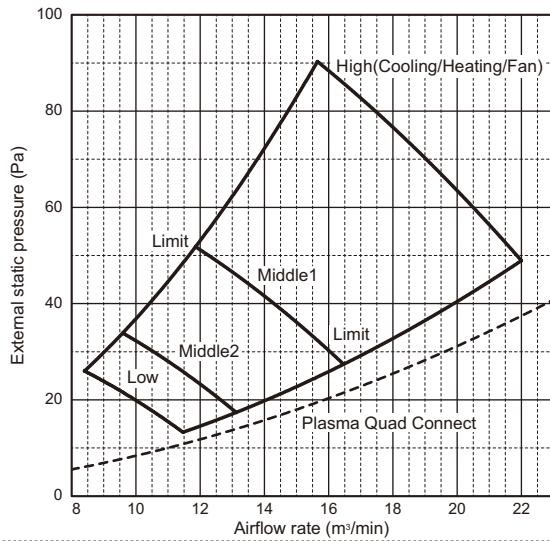

PEFY-M40VMA(L)-A1
 External static pressure : 100Pa
 Power source : 220-240V

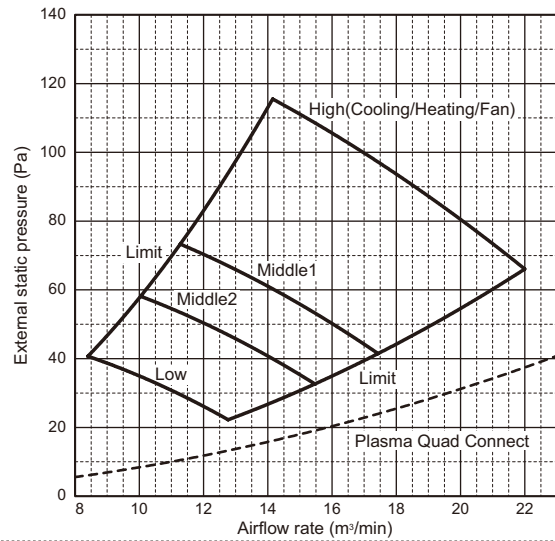

PEFY-M40VMA(L)-A1
 External static pressure : 150Pa
 Power source : 220-240V

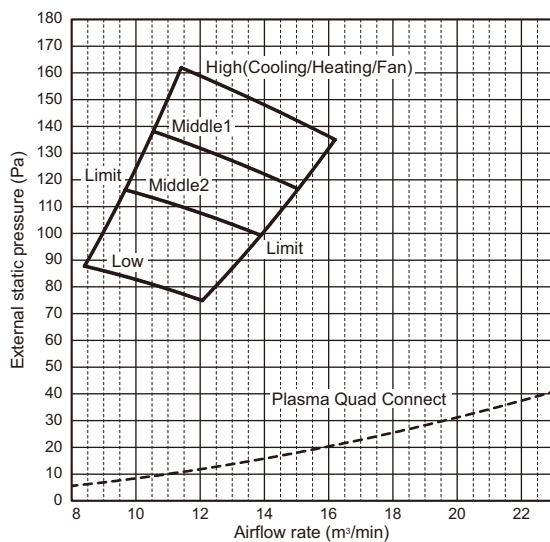

♦The fan characteristic curves (solid line) are the data with no optional parts attached.

6. FAN CHARACTERISTICS CURVES

Ceiling concealed (Medium static pressure type)

PEFY-M-VMA(L)-A1

PEFY-M50VMA(L)-A1

External static pressure : 35Pa
Power source : 220-240V

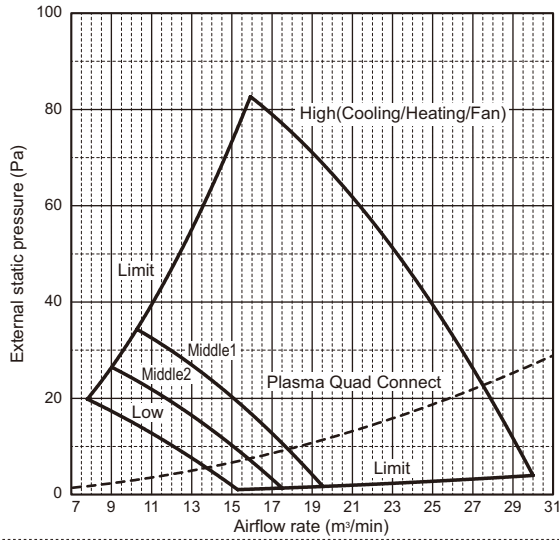

PEFY-M50VMA(L)-A1

External static pressure : 50Pa
Power source : 220-240V

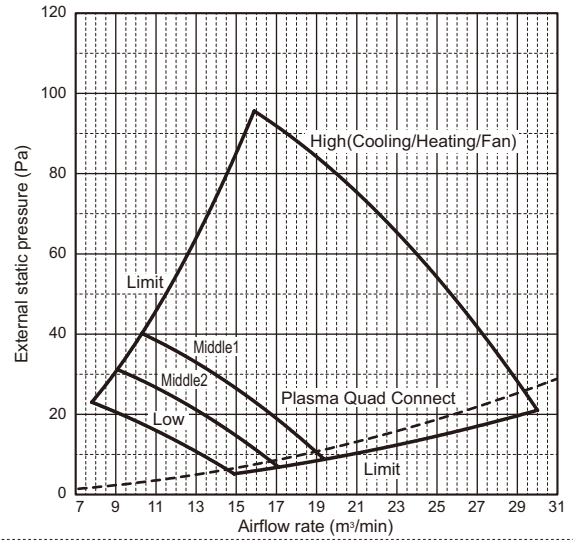

PEFY-M50VMA(L)-A1

External static pressure : 70Pa
Power source : 220-240V

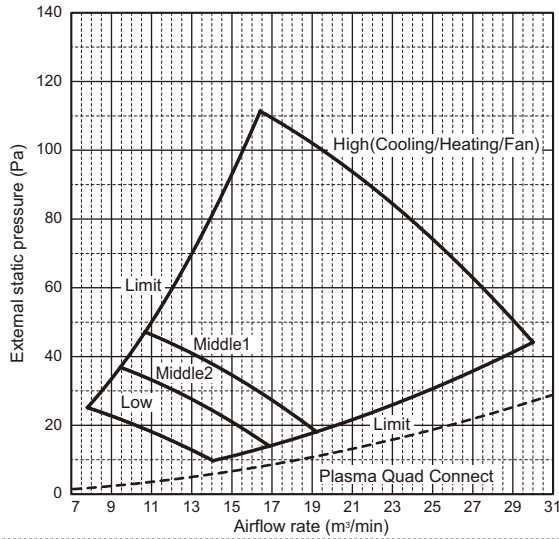

PEFY-M50VMA(L)-A1

External static pressure : 100Pa
Power source : 220-240V

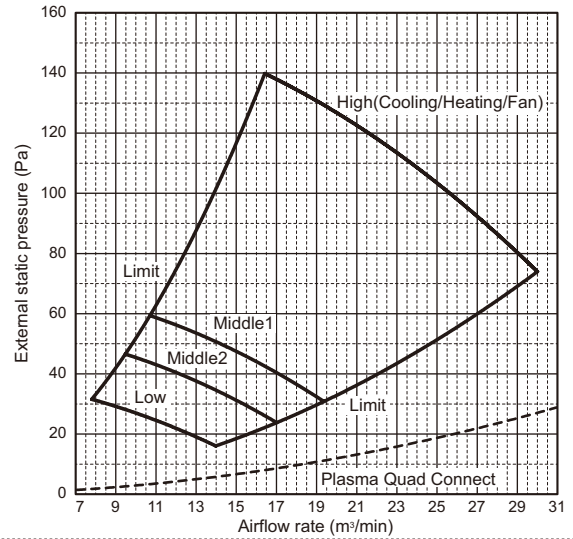

PEFY-M50VMA(L)-A1

External static pressure : 150Pa
Power source : 220-240V

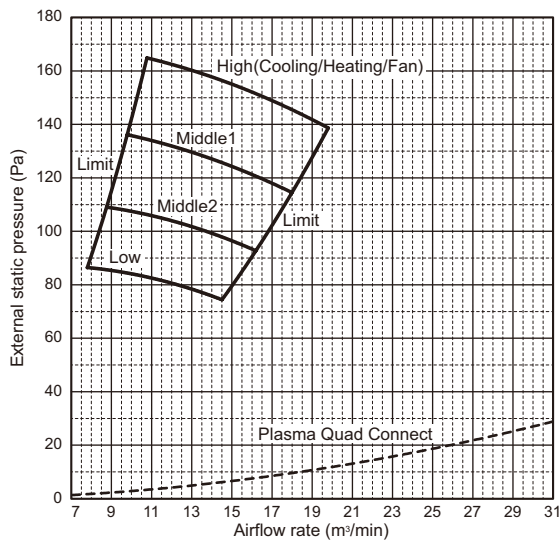

◆The fan characteristic curves (solid line) are the data with no optional parts attached.

6. FAN CHARACTERISTICS CURVES

Ceiling concealed (Medium static pressure type)

PEFY-M-VMA(L)-A1

PEFY-M63VMA(L)-A1

External static pressure : 35Pa
Power source : 220-240V

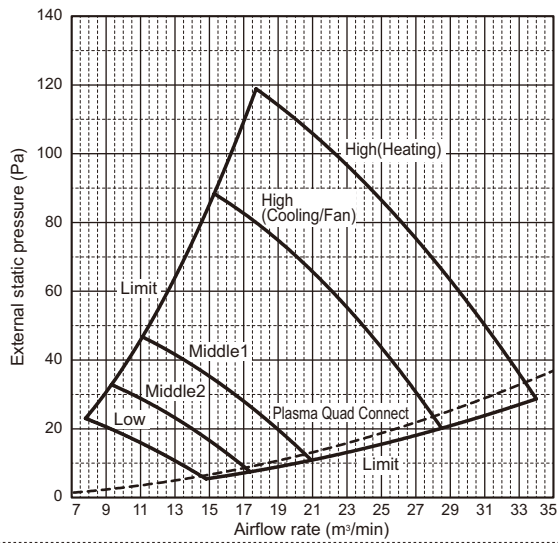

PEFY-M63VMA(L)-A1

External static pressure : 50Pa
Power source : 220-240V

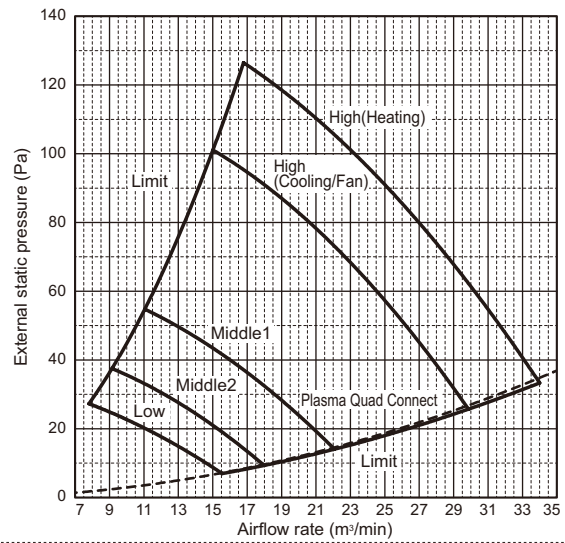

PEFY-M63VMA(L)-A1

External static pressure : 70Pa
Power source : 220-240V

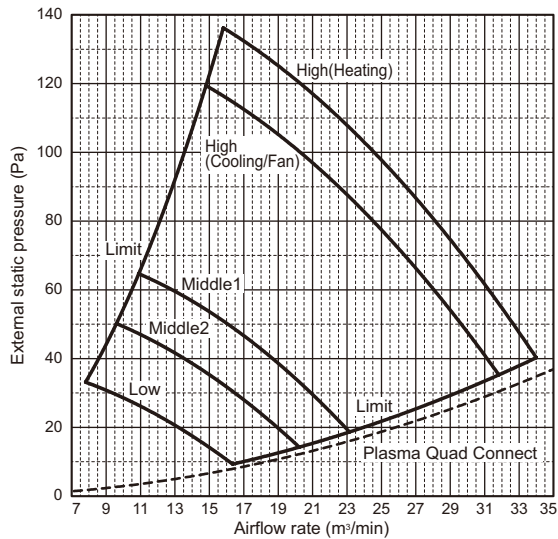

PEFY-M63VMA(L)-A1

External static pressure : 100Pa
Power source : 220-240V

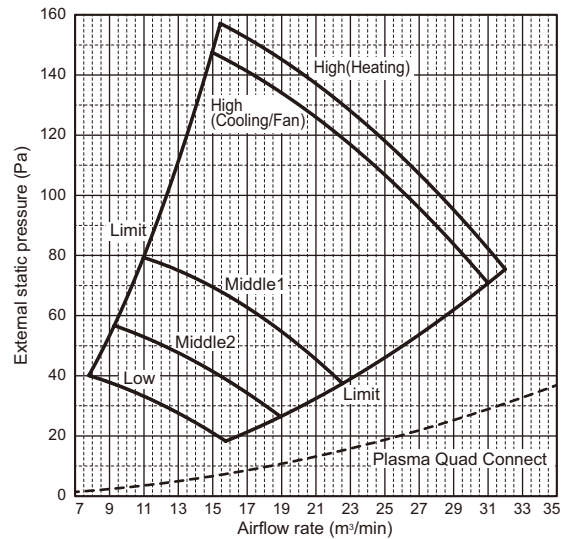

PEFY-M63VMA(L)-A1

External static pressure : 150Pa
Power source : 220-240V

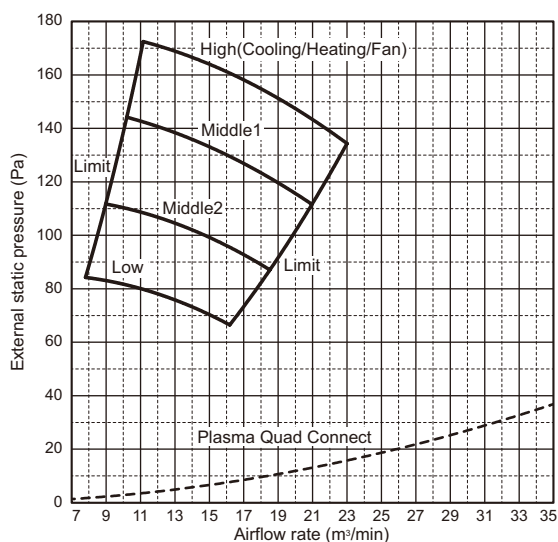

♦The fan characteristic curves (solid line) are the data with no optional parts attached.

6. FAN CHARACTERISTICS CURVES

Ceiling concealed (Medium static pressure type)

PEFY-M-VMA(L)-A1

PEFY-M71, 80VMA(L)-A1

External static pressure : 50Pa
Power source : 220-240V

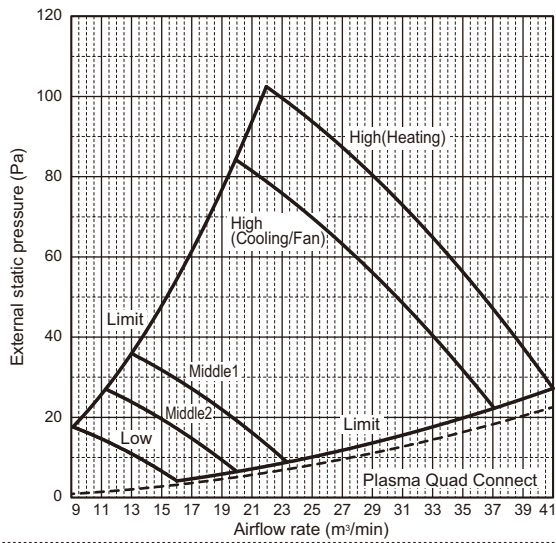

PEFY-M71, 80VMA(L)-A1

External static pressure : 50Pa
Power source : 220-240V

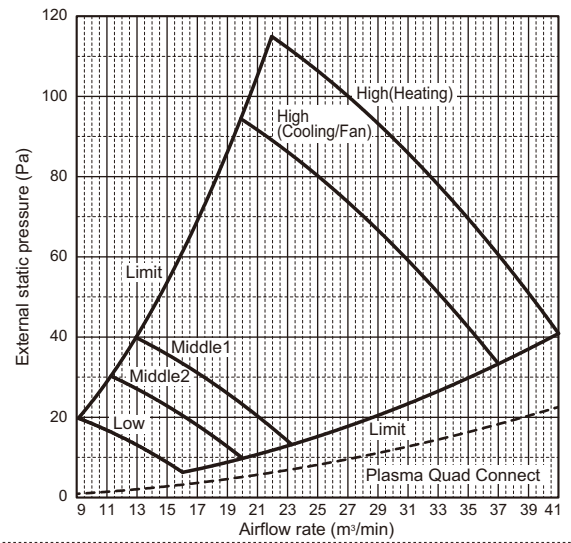

PEFY-M71, 80VMA(L)-A1

External static pressure : 70Pa
Power source : 220-240V

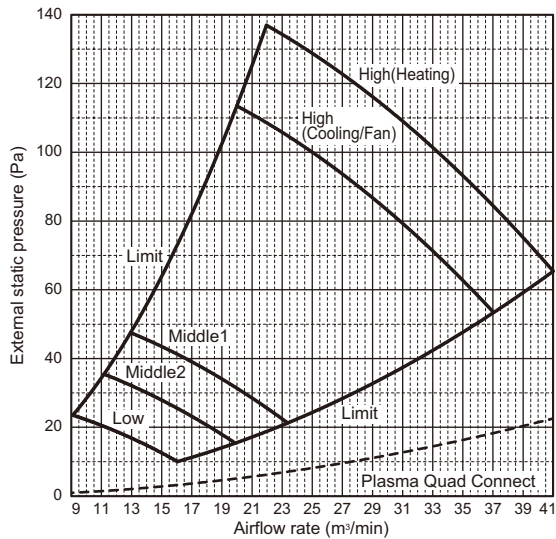

PEFY-M71, 80VMA(L)-A1

External static pressure : 100Pa
Power source : 220-240V

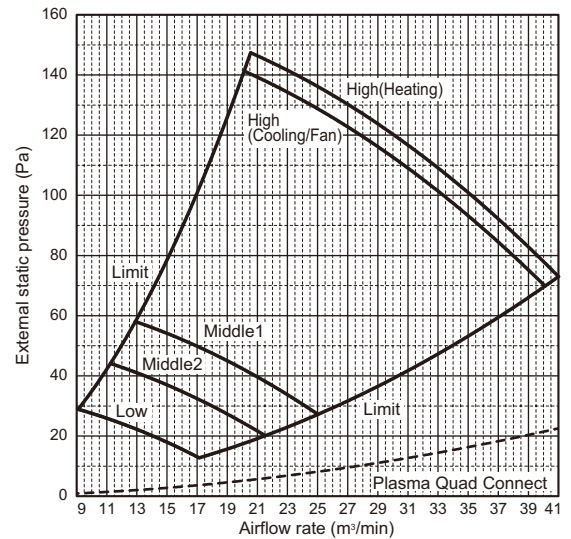

PEFY-M71, 80VMA(L)-A1

External static pressure : 150Pa
Power source : 220-240V

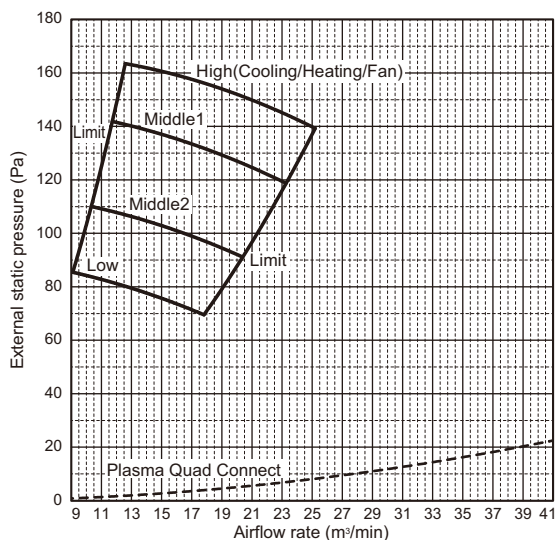

♦The fan characteristic curves (solid line) are the data with no optional parts attached.

6. FAN CHARACTERISTICS CURVES

Ceiling concealed (Medium static pressure type)

PEFY-M-VMA(L)-A1

PEFY-M100VMA(L)-A1

External static pressure : 40Pa

Power source : 220-240V

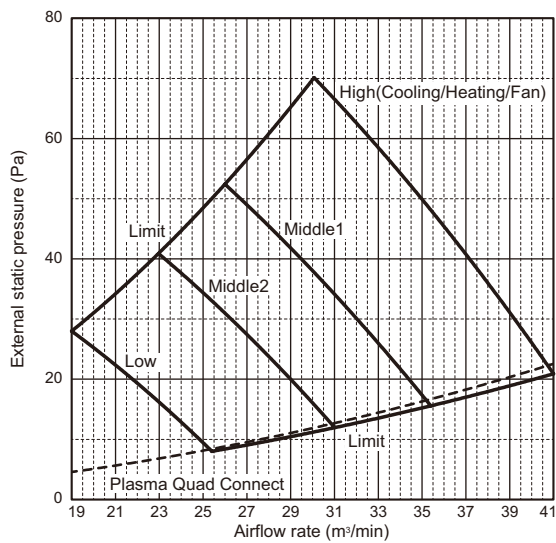

PEFY-M100VMA(L)-A1

External static pressure : 50Pa

Power source : 220-240V

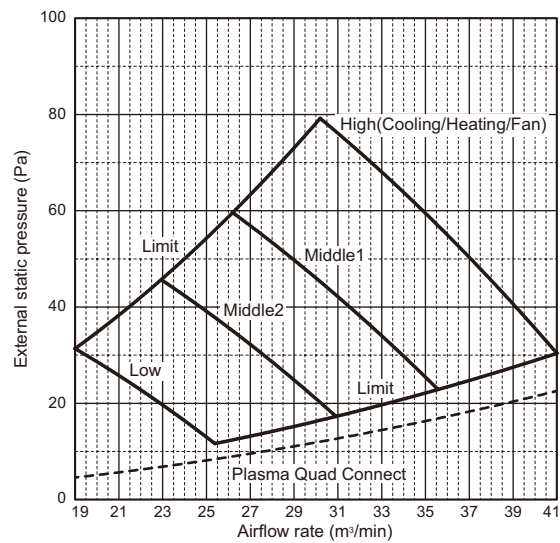

PEFY-M100VMA(L)-A1

External static pressure : 70Pa

Power source : 220-240V

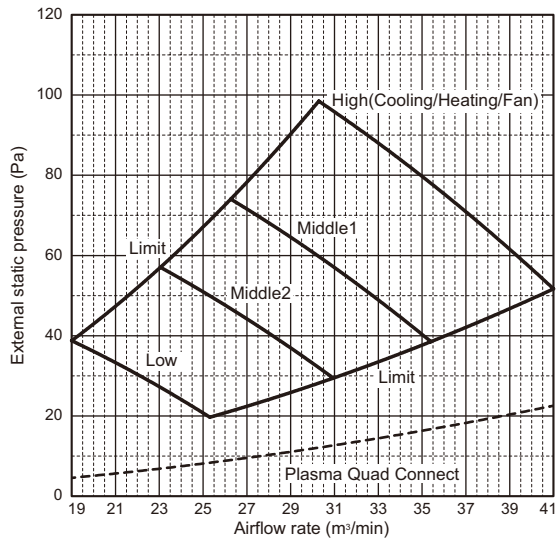

PEFY-M100VMA(L)-A1

External static pressure : 100Pa

Power source : 220-240V

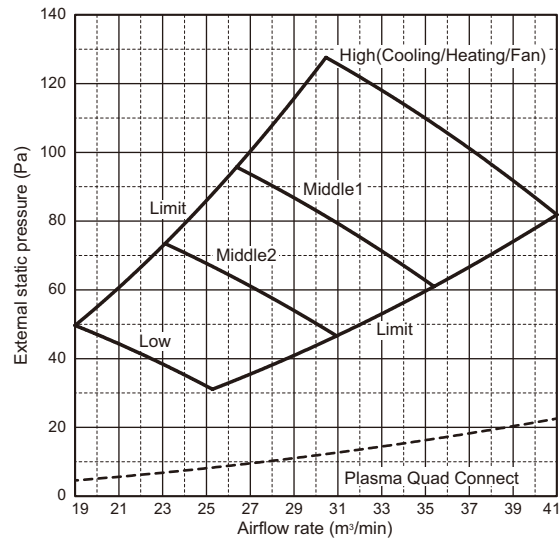

PEFY-M100VMA(L)-A1

External static pressure : 150Pa

Power source : 220-240V

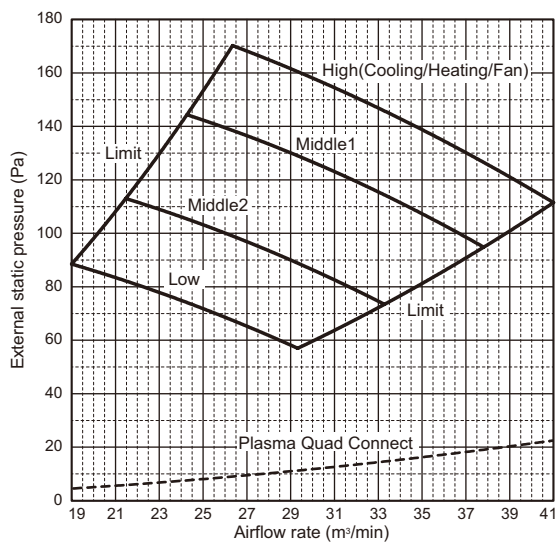

♦The fan characteristic curves (solid line) are the data with no optional parts attached.

6. FAN CHARACTERISTICS CURVES

Ceiling concealed (Medium static pressure type)

PEFY-M-VMA(L)-A1

PEFY-M125VMA(L)-A1

External static pressure : 40Pa
Power source : 220-240V

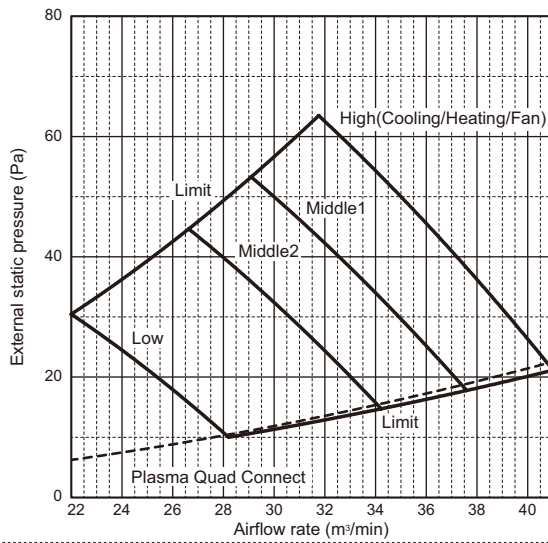

PEFY-M125VMA(L)-A1

External static pressure : 50Pa
Power source : 220-240V

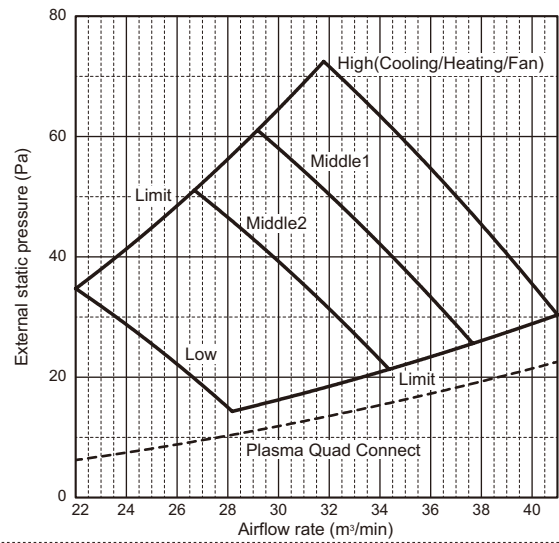

PEFY-M125VMA(L)-A1

External static pressure : 70Pa
Power source : 220-240V

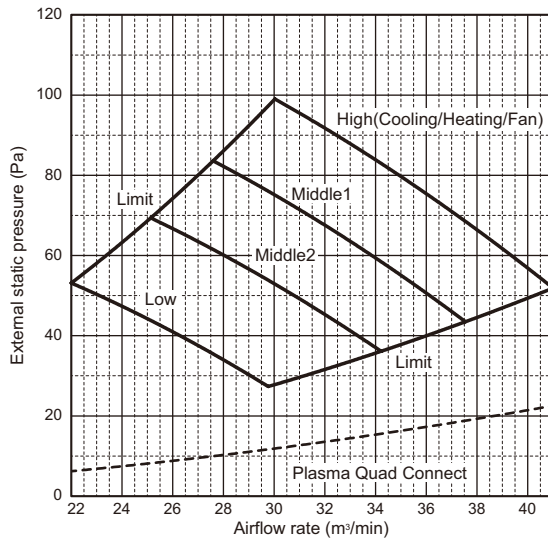

PEFY-M125VMA(L)-A1

External static pressure : 100Pa
Power source : 220-240V

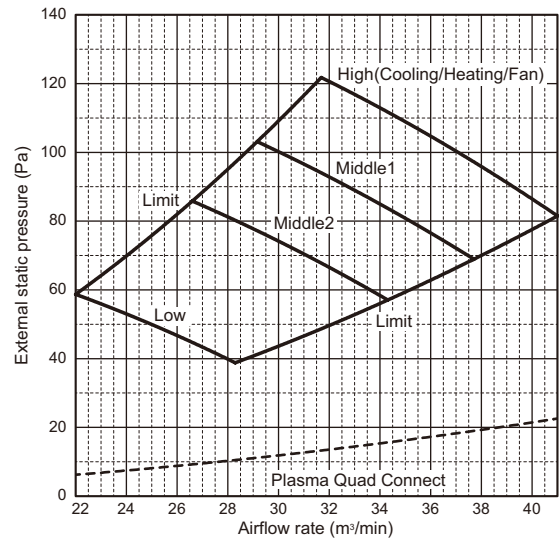

PEFY-M125VMA(L)-A1

External static pressure : 150Pa
Power source : 220-240V

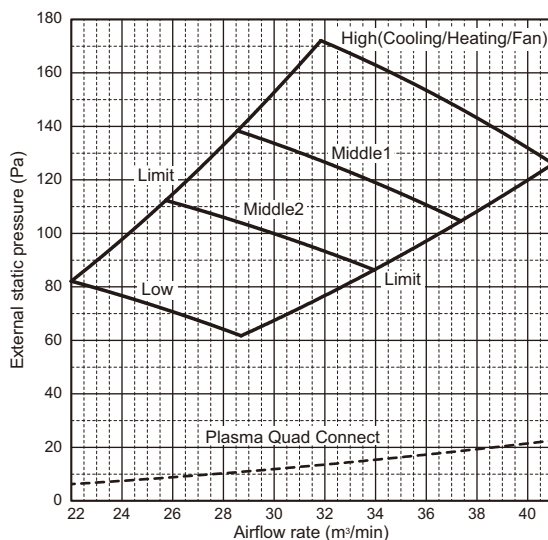

♦The fan characteristic curves (solid line) are the data with no optional parts attached.

PEFY-M140VMA(L)-A1
 External static pressure : 40Pa
 Power source : 220-240V

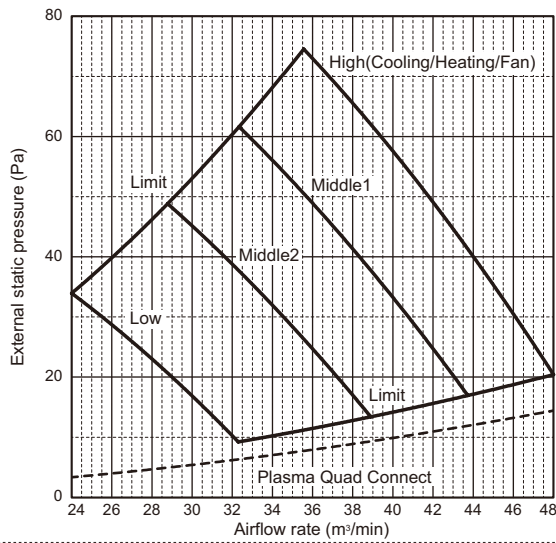

PEFY-M140VMA(L)-A1
 External static pressure : 50Pa
 Power source : 220-240V

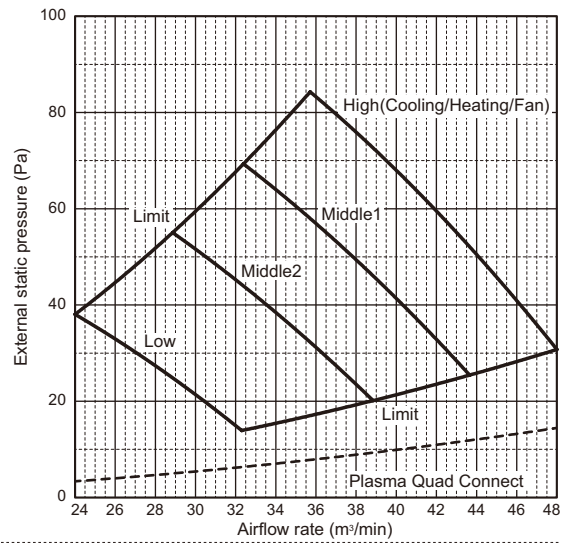

PEFY-M140VMA(L)-A1
 External static pressure : 70Pa
 Power source : 220-240V

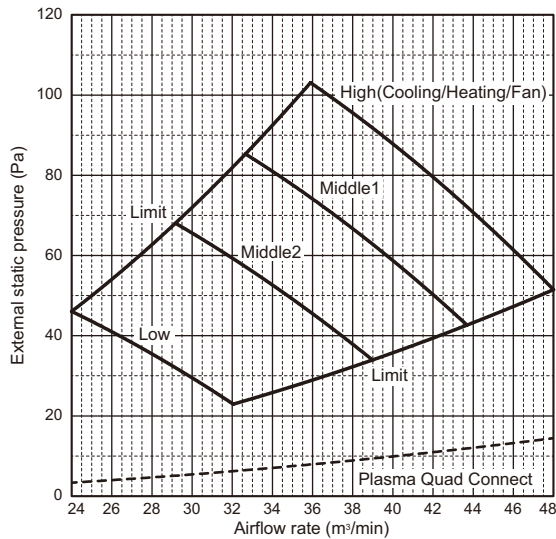

PEFY-M140VMA(L)-A1
 External static pressure : 100Pa
 Power source : 220-240V

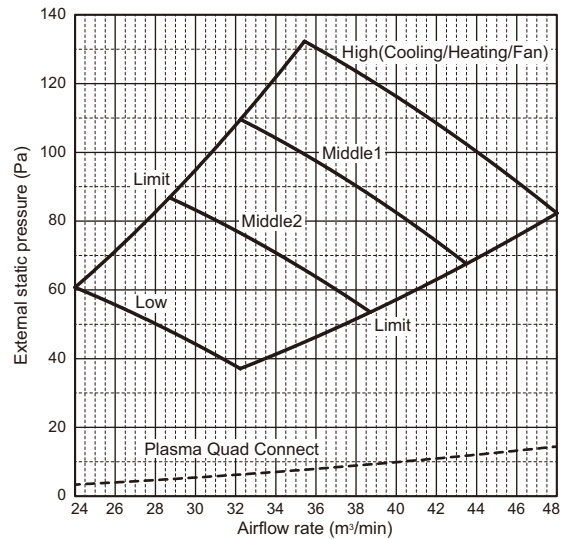

PEFY-M140VMA(L)-A1
 External static pressure : 150Pa
 Power source : 220-240V

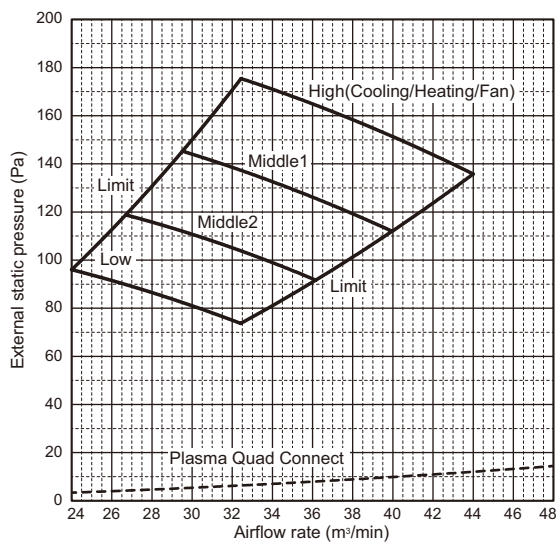

♦The fan characteristic curves (solid line) are the data with no optional parts attached.

7-1. Correction by fan speed

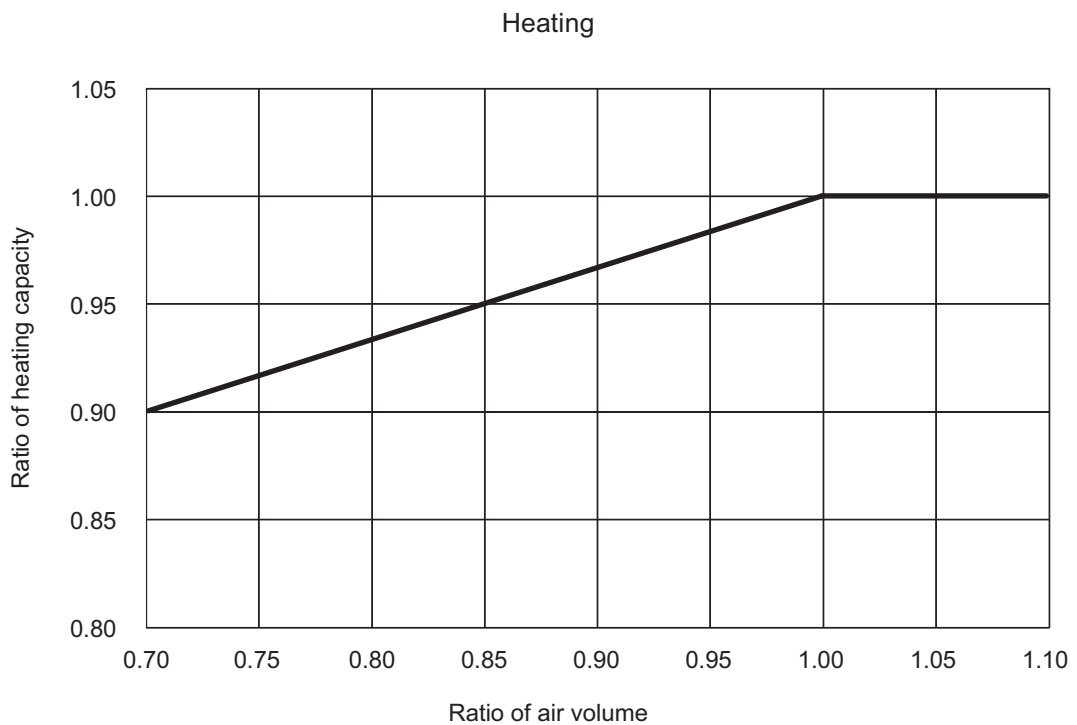
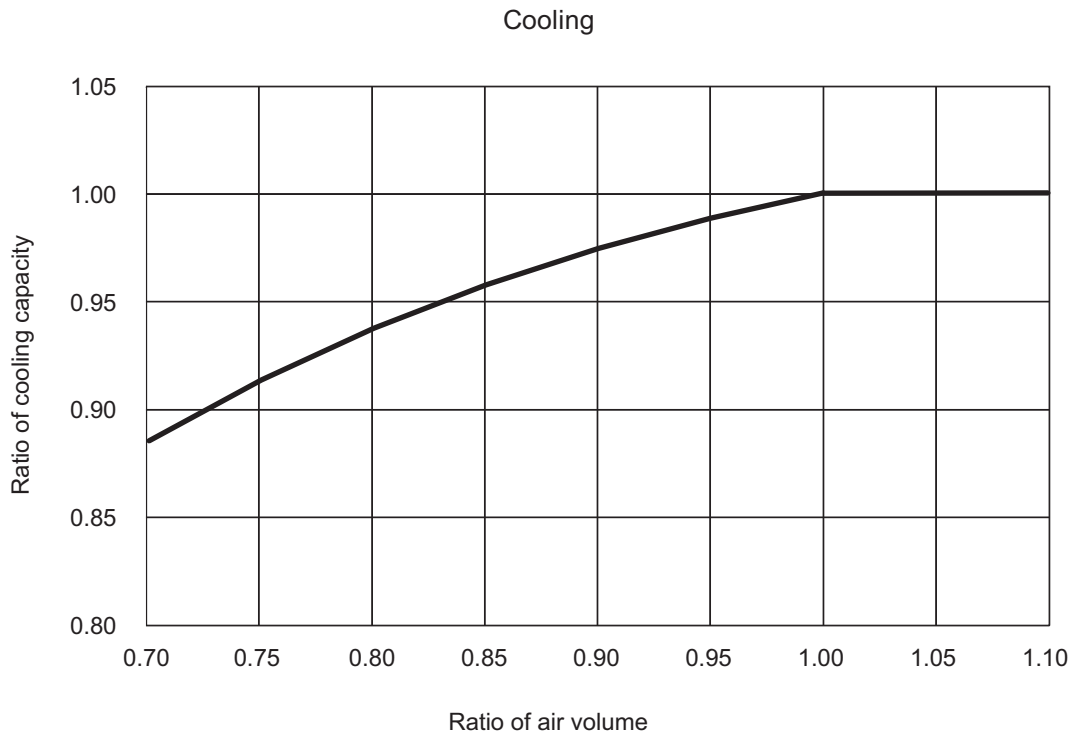

[Notes]

- The graphs only apply to the PLFY-M-VEM6-E and the PEFY-M-VMA-A1 series.
- Values in the graphs show reference values under the rated air condition and when the airflow volume of all connected indoor units is assumed to change equally.
- Values in the graphs vary, depending on the fan setting of individual units and on air conditions. The values here do not indicate guaranteed capacity.

8. ELECTRICAL CHARACTERISTICS

Ceiling concealed (Medium static pressure type)

Symbols: MCA (Max.Circuit Amps =1.25xFLA), FLA (Full Load Amps)
IFM (Indoor Fan Motor), Output (Fan motor rated output)

PEFY-M-VMA(L)-A1	Power supply			IFM	
	Volts/Hz	Range +-10%	MCA (A)	Output (kW)	FLA (A)
PEFY-M20VMA(L)-A1	220-240V/50Hz	Max.: 264V Min.: 198V	0.93	0.085	0.74
PEFY-M25VMA(L)-A1			0.93	0.085	0.74
PEFY-M32VMA(L)-A1			1.19	0.085	0.95
PEFY-M40VMA(L)-A1			1.53	0.121	1.22
PEFY-M50VMA(L)-A1			2.13	0.121	1.70
PEFY-M63VMA(L)-A1			2.20	0.121	1.76
PEFY-M71VMA(L)-A1			2.35	0.300	1.88
PEFY-M80VMA(L)-A1			2.35	0.300	1.88
PEFY-M100VMA(L)-A1			2.81	0.300	2.25
PEFY-M125VMA(L)-A1			2.93	0.300	2.34
PEFY-M140VMA(L)-A1			3.29	0.300	2.63

PEFY-M-VMA(L)-A1

9-1. Optional parts line up for the Indoor unit

	Filter box	Plasma Quad Connect	PQ attachment (Rear inlet)	PQ attachment (Bottom inlet)	PQ box
PEFY-M20, 25, 32VMA(L)-A1	PAC-KE91TB-E	MAC-100FT-E	PAC-HA31PAR	PAC-HA31PAU	PAC-KE91PTB-E
PEFY-M40VMA(L)-A1	PAC-KE92TB-E	MAC-100FT-E	PAC-HA31PAR	PAC-HA31PAU	PAC-KE92PTB-E
PEFY-M50, 63VMA(L)-A1	PAC-KE93TB-E	MAC-100FT-E	PAC-HA31PAR	PAC-HA31PAU	PAC-KE93PTB-E
PEFY-M71, 80, 100, 125VMA(L)-A1	PAC-KE94TB-E	MAC-100FT-E	PAC-HA31PAR	PAC-HA31PAU	PAC-KE94PTB-E
PEFY-M140VMA(L)-A1	PAC-KE95TB-E	MAC-100FT-E	PAC-HA31PAR	PAC-HA31PAU	PAC-KE95PTB-E

● PEFY-M-VMA(L)-A1

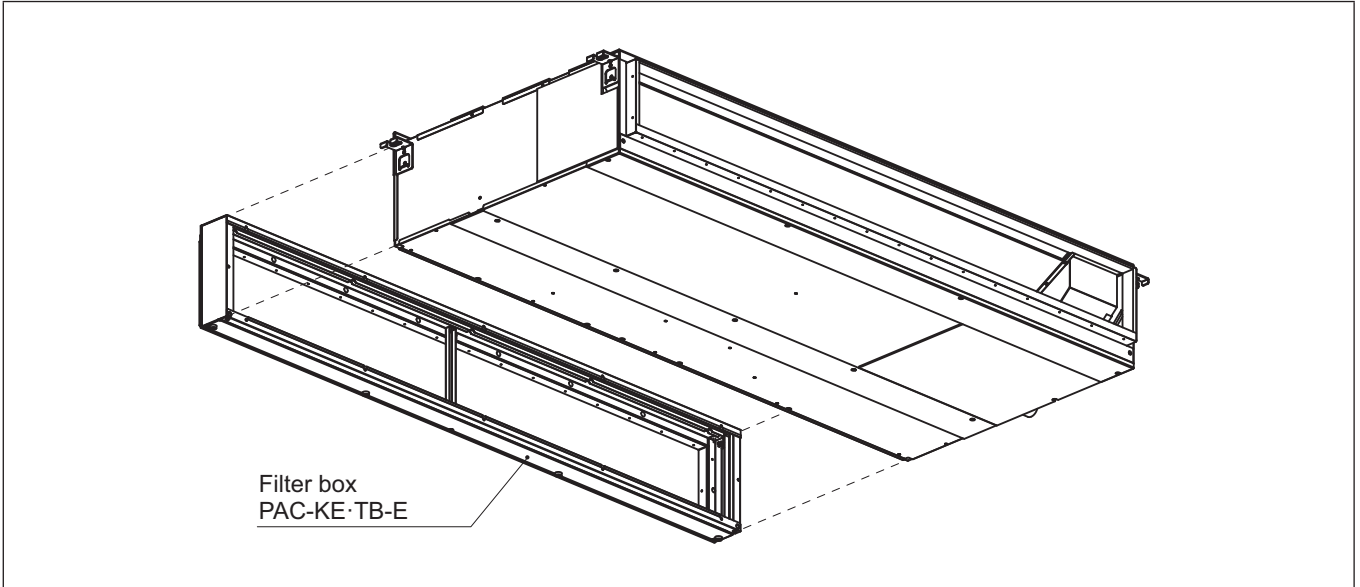

9-2. Filter box

PAC-KE-TB-E

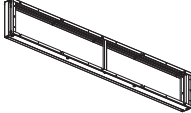
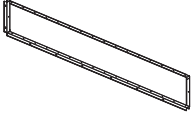
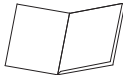
Item	1 Screw	2 Filter box	3 FLANGE	4 Installation manual	
Quantity	30	1	1	1	
Shape					

Detailed installation information should be referred to its Installation Manual.







9-3. Plasma Quad Connect

Static pressure loss is referred to 6 "FAN CHARACTERISTICS CURVES".

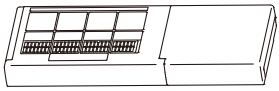
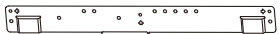
Plasma Quad Connect (MAC-100FT-E) should be used together with PQ box or PQ attachment (PAC-HA31PAR or PAC-HA31PAU).

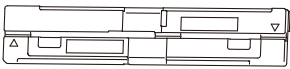

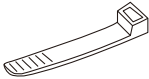

*Attaching the Plasma Quad Connect increases the pressure loss. Adjust the external static pressure setting as necessary. For the adjustment procedure, see the Installation Manual for the indoor unit.

Plasma Quad Connect (MAC-100FT-E)

Item	Plasma Quad Connect (with connecting cable)	Installation plate	Fixing screw for Plasma Quad Connect and Installation plate 4 × 25 mm
Quantity	1	1	5
Shape			
Item	Spacer Note: The spacer is used as packaging material.	Mounting cord clamp	Cable tie
Quantity	1	1	1
Shape			
Item	Screw for Mounting cord clamp 4 × 16 (Use when joining room air conditioner parts)		
Quantity	1		
Shape			

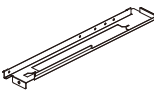
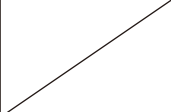

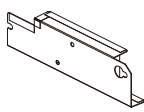

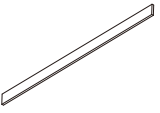
Detailed installation information should be referred to its Installation Manual.

PQ attachment (Rear inlet) (PAC-HA31PAR)

Item	PLATE 1	PLATE 2	PLATE 3	PLATE 4	Screw (4 × 10)	Screw (5 × 10)	RUBBER PLATE
Quantity	1	-	1	1	3	2	2
Shape							

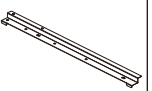
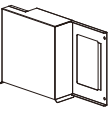
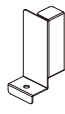



Detailed installation information should be referred to its Installation Manual.

PQ attachment (Bottom inlet) (PAC-HA31PAU)

Item	PLATE 1	PLATE 2	PLATE 3	PLATE 4	Screw (4 × 10)	CABLE STRAP	WIRE SADDLE	RUBBER PLATE
Quantity	1	1	1	1	9	1	1	2
Shape								

Detailed installation information should be referred to its Installation Manual.

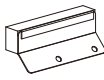
PQ box (PAC-KE91, 92, 93, 94, 95PTB-E)

Item	Screw (4 × 10)	CABLE STRAP	SUCTION FLANGE	WIRING COVER	RUBBER PLATE
Quantity	22 (PAC-KE91PTB-E) 26 (PAC-KE92, 93PTB-E) 32 (PAC-KE94, 95PTB-E)	2	1	1	2
Shape					

Detailed installation information should be referred to its Installation Manual.

PEFY-M-VMA(L)-A1

PEFY-M20, 25, 32, 40, 50, 63, 71, 80, 100, 125, 140VMA(L)-A1
with PQ attachment (Rear inlet) and Plasma Quad Connect

Unit: mm

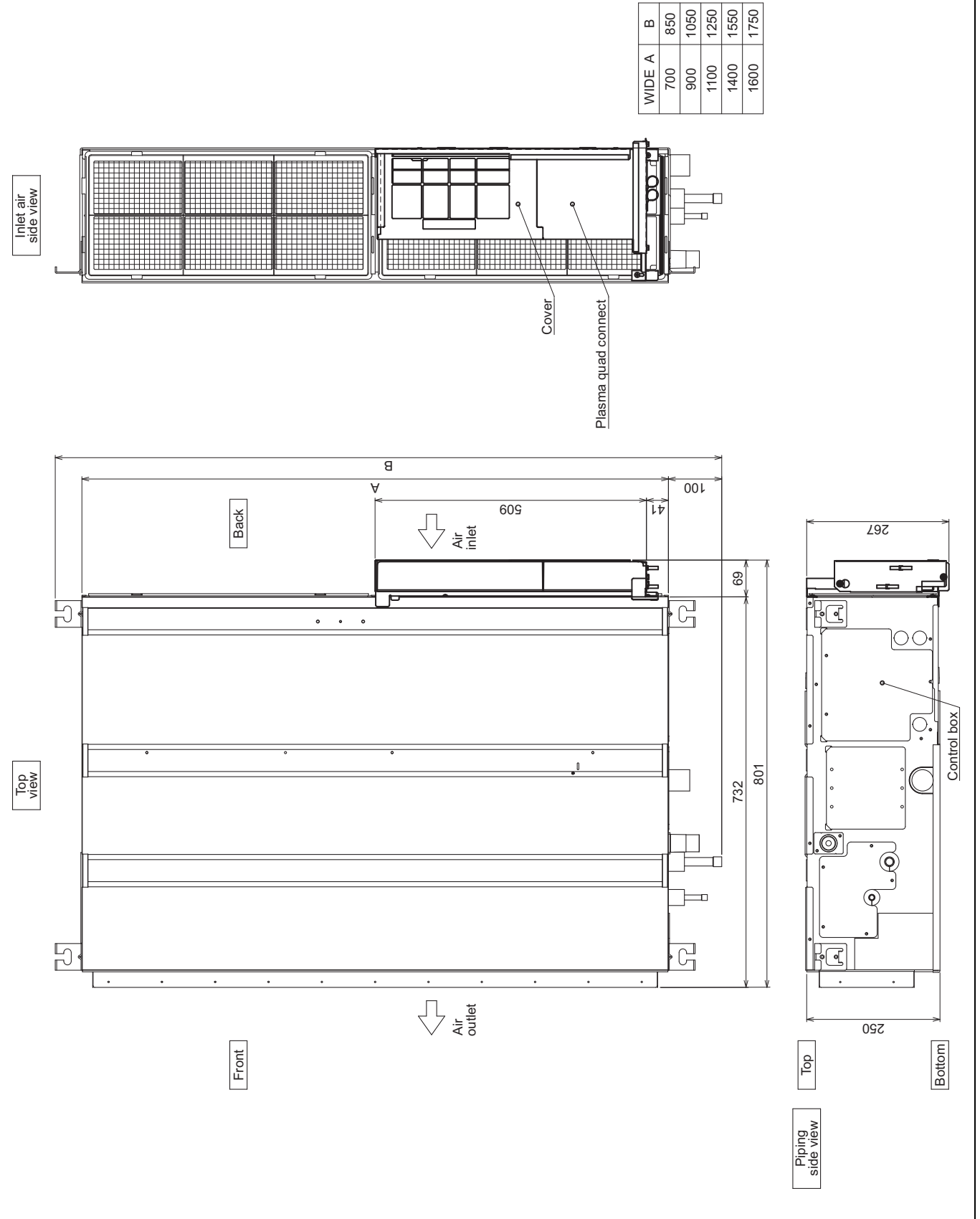

WIDE A	B
700	850
900	1050
1100	1250
1400	1550
1600	1750

Model	WIDE A	B
PEFY-M20,25,32VMA(L)-A1	700	850
PEFY-M40VMA(L)-A1	900	1050
PEFY-M50,63VMA(L)-A1	1100	1250

Model	WIDE A	B
PEFY-M71,80,100,125VMA(L)-A1	1400	1550
PEFY-M140VMA(L)-A1	1600	1750

The drawing above is a sample image of the optional parts being installed on a unit.

PEFY-M20, 25, 32, 40, 50, 63, 71, 80, 100, 125, 140VMA(L)-A1 with PQ attachment (Rear inlet) and Plasma Quad Connect

Unit: mm

[Maintenance access space]
Secure enough access space to allow for the maintenance, inspection, and replacement of the motor, fan, drain pump, heat exchanger, and control box in one of the following ways.
Select an installation site for the indoor unit so that its maintenance access space will not be obstructed by beams or other objects.

- (1) When a space of 300mm or more is available below the unit between the unit and the ceiling. (Fig.1)
- Create access door 1 and 2 (450x450mm each) as shown in Fig.2.
- (2) When a space is not required if enough space is available below the unit for a maintenance worker to work in. (At least 20mm of space should be left below the unit as shown in Fig.3.)
- Create access door 1 diagonally below the control box and access door 3 below the unit as shown in Fig.4.
- or
- Create access door 4 below the control box and the unit as shown in Fig.5.
- (3) For maintenance if there is more than 170mm from the top surface, the cover can be pulled out without removing the PQ attachment. (Fig.1, Fig.3)

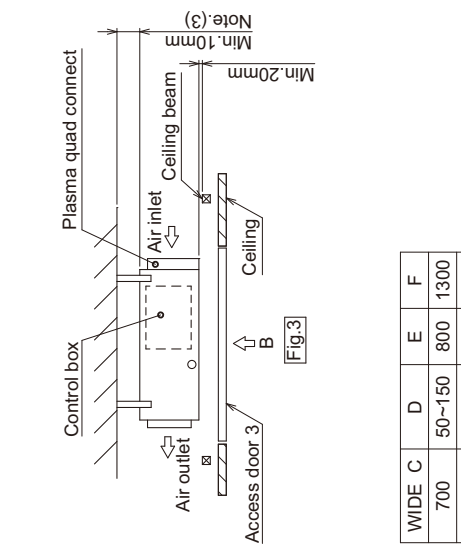
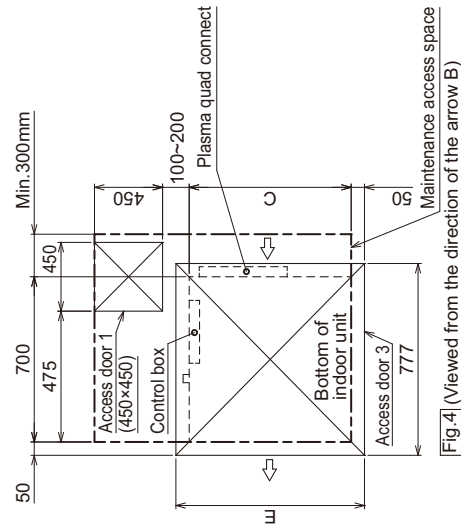
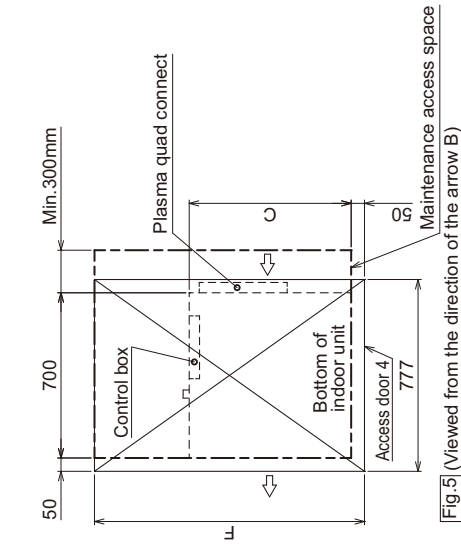
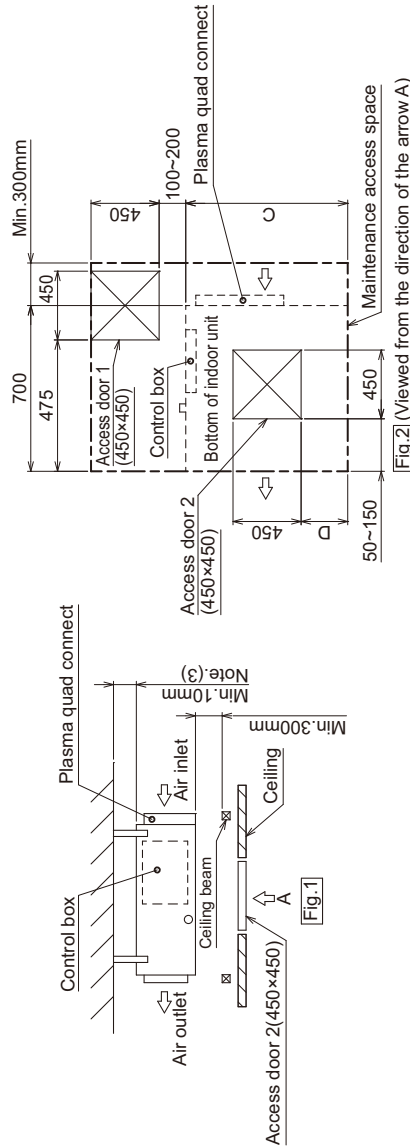

WIDE C	D	E	F
700	50~150	800	1300
900	150~250	1000	1500
1100	250~350	1200	1700
1400	400~500	1500	2000
1600	500~600	1700	2200

Model	WIDE C	D	E	F
PEFY-M20,25,32VMA(L)-A1	700	50~150	800	1300
PEFY-M40VMA(L)-A1	900	150~250	1000	1500
PEFY-M50,63VMA(L)-A1	1100	250~350	1200	1700

Model	WIDE C	D	E	F
PEFY-M71,80,100,125VMA(L)-A1	1400	400~500	1500	2000
PEFY-M140VMA(L)-A1	1600	500~600	1700	2200

The drawing above is a sample image of the optional parts being installed on a unit.

PEFY-M20, 25, 32, 40, 50, 63, 71, 80, 100, 125, 140VMA(L)-A1 with PQ attachment (Bottom inlet) and Plasma Quad Connect

Unit: mm

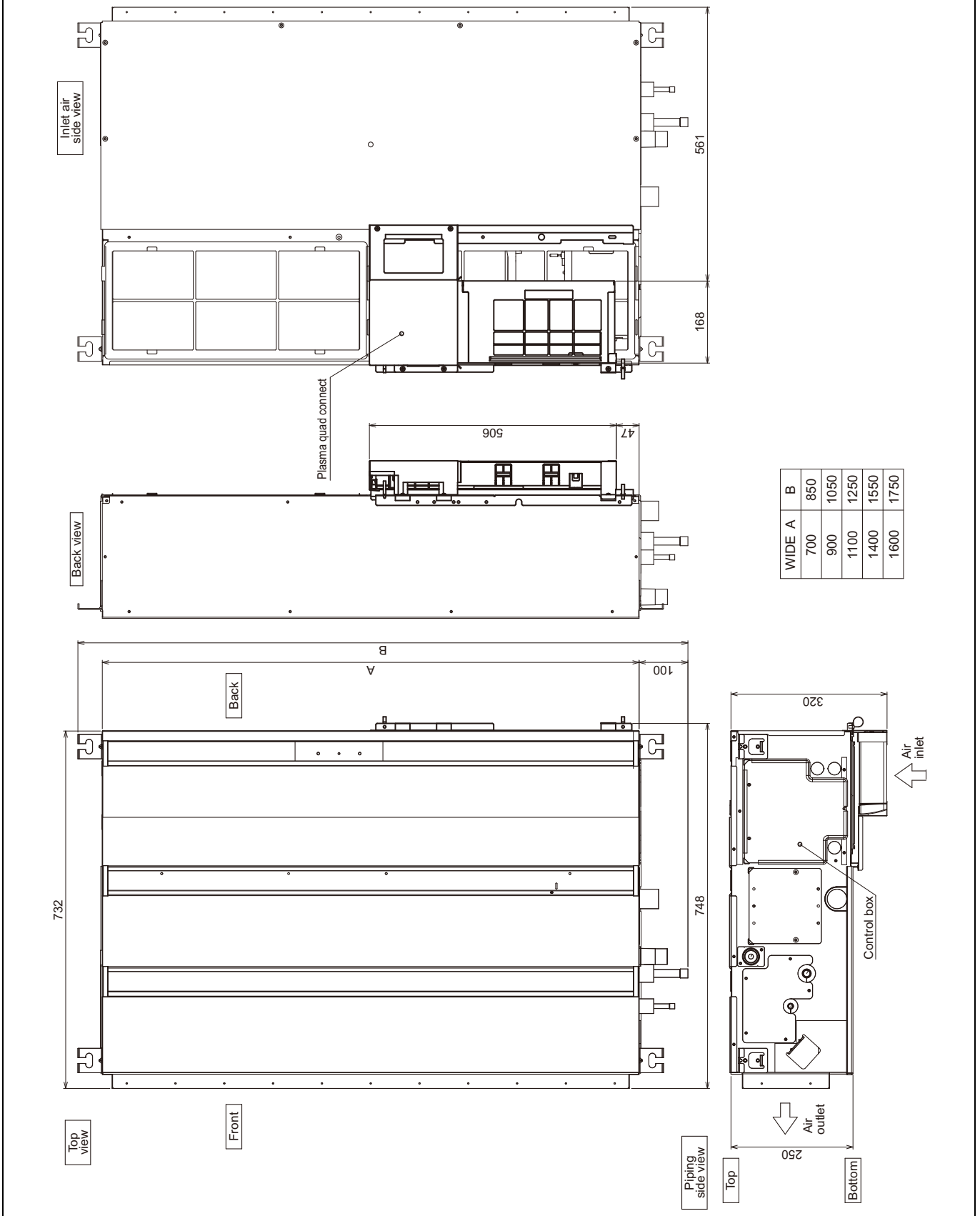

Model	WIDE A	B
PEFY-M20,25,32VMA(L)-A1	700	850
PEFY-M40VMA(L)-A1	900	1050
PEFY-M50,63VMA(L)-A1	1100	1250

Model	WIDE A	B
PEFY-M71,80,100,125VMA(L)-A1	1400	1550
PEFY-M140VMA(L)-A1	1600	1750

The drawing above is a sample image of the optional parts being installed on a unit.

PEFY-M20, 25, 32, 40, 50, 63, 71, 80, 100, 125, 140VMA(L)-A1
with PQ attachment (Bottom inlet) and Plasma Quad Connect

Unit: mm

PEFY-M-VMA(L)-A1

[Maintenance access space]
Secure enough access space to allow for the maintenance, inspection, and replacement of the motor, fan, drain pump, heat exchanger, and control box in one of the following ways.
Select an installation site for the indoor unit so that its maintenance access space will not be obstructed by beams or other objects.

- (1) When a space of 300mm or more is available below the unit between the unit and the ceiling. (Fig. 1)
 - Create access door 1 and 2 (450x450mm each) as shown in Fig.2.
- (2) When a space of less than 300mm is available below the unit between the unit and the ceiling. (At least 20mm of space should be left below the unit as shown in Fig.3.)
 - Create access door 1 diagonally below the control box and access door 3 below the unit as shown in Fig.4.
 - or
 - Create access door 4 below the control box and the unit as shown in Fig.5.

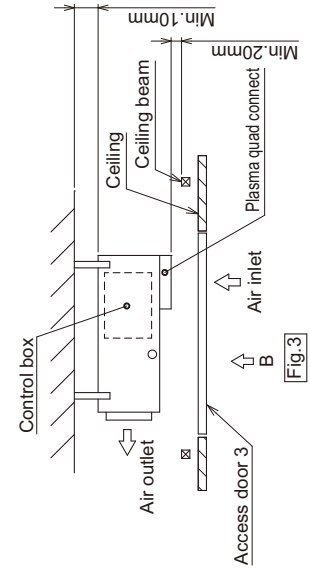
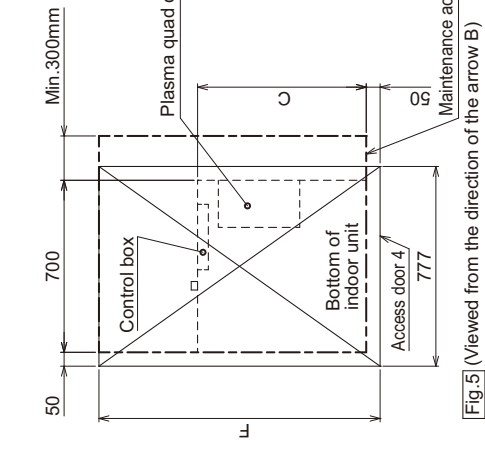
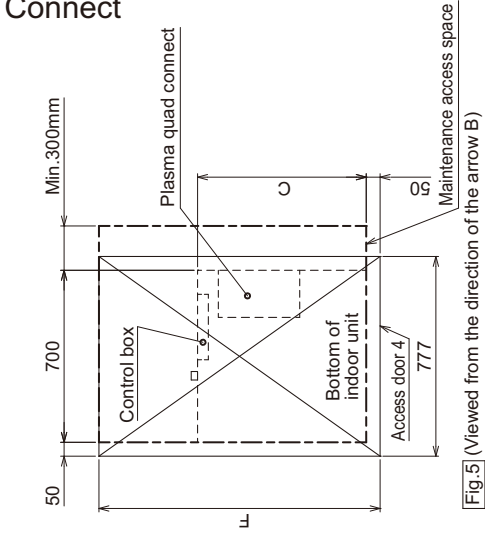
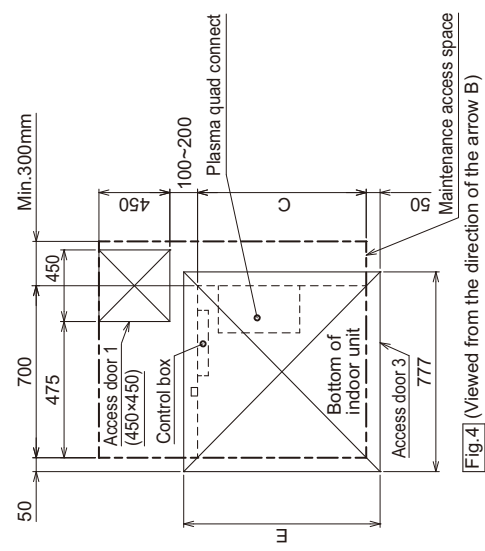
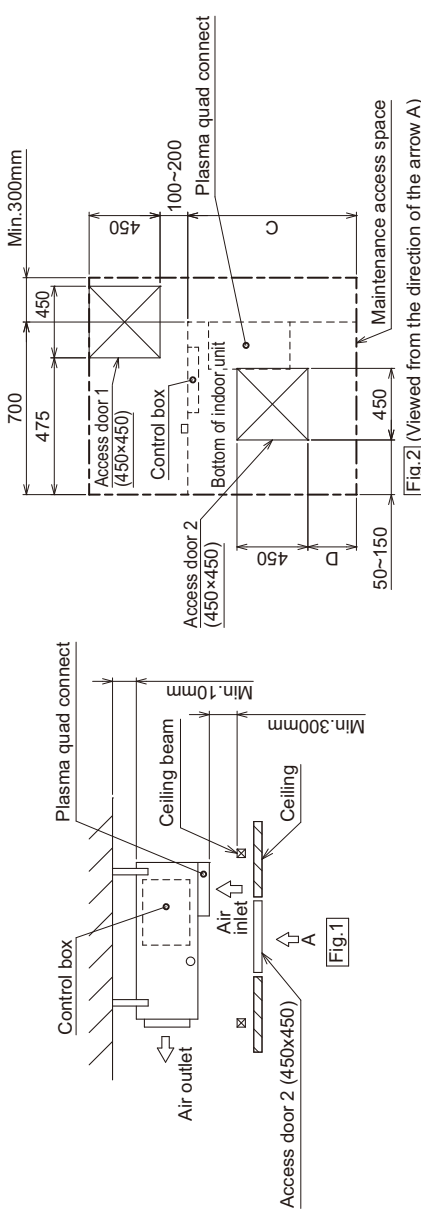

WIDE C	D	E	F
700	50~150	800	1300
900	150~250	1000	1500
1100	250~350	1200	1700
1400	400~500	1500	2000
1600	500~600	1700	2200

Model	WIDE C	D	E	F
PEFY-M20,25,32VMA(L)-A1	700	50~150	800	1300
PEFY-M40VMA(L)-A1	900	150~250	1000	1500
PEFY-M50,63VMA(L)-A1	1100	250~350	1200	1700

Model	WIDE C	D	E	F
PEFY-M71,80,100,125VMA(L)-A1	1400	400~500	1500	2000
PEFY-M140VMA(L)-A1	1600	500~600	1700	2200

The drawing above is a sample image of the optional parts being installed on a unit.

PEFY-M20, 25, 32, 40, 50, 63, 71, 80, 100, 125, 140VMA(L)-A1
with PQ box and Plasma Quad Connect

Unit: mm

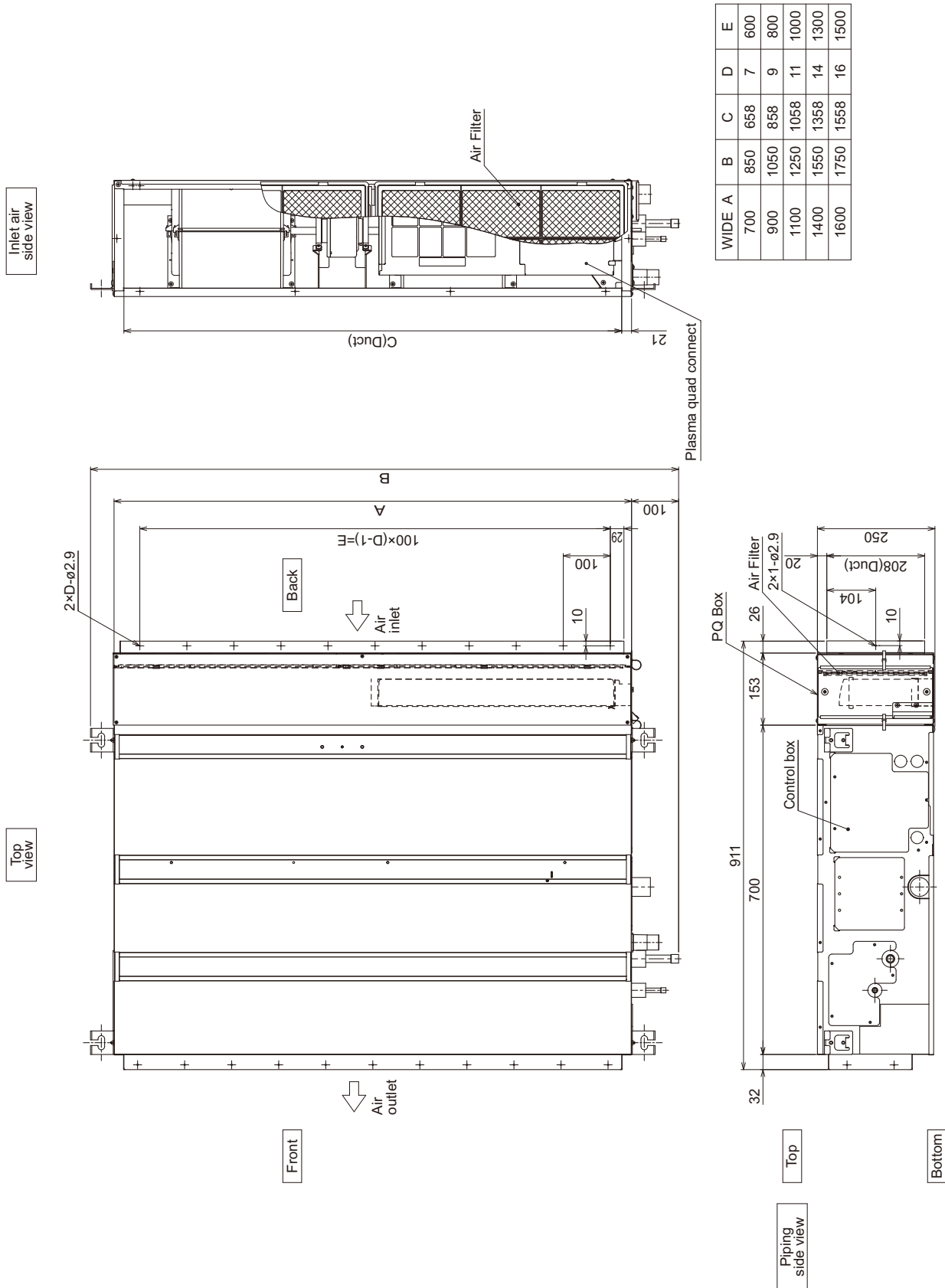

Model	WIDE A	B	C	D	E
PEFY-M20,25,32VMA(L)-A1	700	850	658	7	600
PEFY-M40VMA(L)-A1	900	1050	858	9	800
PEFY-M50,63VMA(L)-A1	1100	1250	1058	11	1000

Model	WIDE A	B	C	D	E
PEFY-M71,80,100,125VMA(L)-A1	1400	1550	1358	14	1300
PEFY-M140VMA(L)-A1	1600	1750	1558	16	1500

The drawing above is a sample image of the optional parts being installed on a unit.

PEFY-M20, 25, 32, 40, 50, 63, 71, 80, 100, 125, 140VMA(L)-A1
with PQ box and Plasma Quad Connect

Unit: mm

PEFY-M-VMA(L)-A1

[Maintenance access space]
Secure enough access space to allow for the maintenance, inspection, and replacement of the motor, fan, drain pump, heat exchanger, and control box in one of the following ways.
Select an installation site for the indoor unit so that its maintenance access space will not be obstructed by beams or other objects.

- (1) When a space of 300mm or more is available below the unit between the unit and the ceiling. (Fig.1)
 - Create access door 1 and 2 (450x450mm each) as shown in Fig.2.
(Access door 2 is not required if enough space is available below the unit for a maintenance worker to work in.)
- (2) When a space of less than 300mm is available below the unit between the unit and the ceiling. (At least 20mm of space should be left below the unit as shown in Fig.3.)
 - Create access door 1 diagonally below the control box and access door 3 below the unit as shown in Fig.4.
 - or
 - Create access door 4 below the control box and the unit as shown in Fig.5.

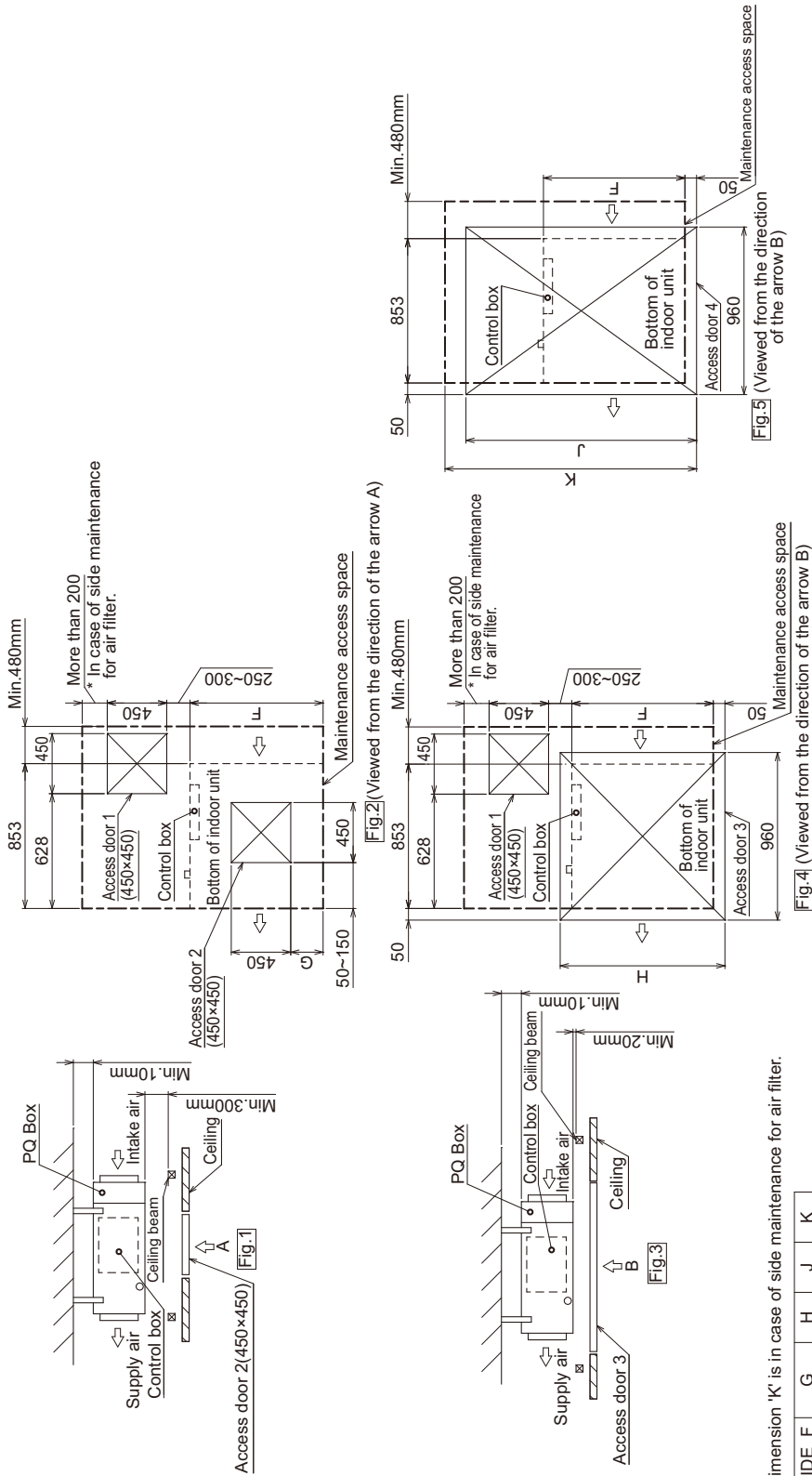

* Dimension 'K' is in case of side maintenance for air filter.

WIDE F	G	H	J	K
700	50~150	800	1300	1450
900	150~250	1000	1500	1850
1100	250~350	1200	1700	-
1400	400~500	1500	2000	2150
1600	500~600	1700	2200	2550

Model	WIDE F	G	H	J	K
PEFY-M20,25,32VMA(L)-A1	700	50~150	800	1300	1450
PEFY-M40VMA(L)-A1	900	150~250	1000	1500	1850
PEFY-M50,63VMA(L)-A1	1100	250~350	1200	1700	-

Model	WIDE F	G	H	J	K
PEFY-M71,80,100,125VMA(L)-A1	1400	400~500	1500	2000	2150
PEFY-M140VMA(L)-A1	1600	500~600	1700	2200	2550

The drawing above is a sample image of the optional parts being installed on a unit.

⚠ Warning

- Do not use refrigerant other than the type indicated in the manuals provided with the unit and on the nameplate.
 - Doing so may cause the unit or pipes to burst, or result in explosion or fire during use, repair, or at the time of disposal of the unit.
 - It may also be in violation of applicable laws.
 - MITSUBISHI ELECTRIC CORPORATION cannot be held responsible for malfunctions or accidents resulting from the use of the wrong type of refrigerant.
- Our air conditioning equipment and heat pumps contain a fluorinated greenhouse gas, R32 or R410A.

MITSUBISHI ELECTRIC CORPORATION

www.MitsubishiElectric.com