

PARTS CATALOG

Series PCFY Ceiling Suspended R410A

Indoor unit
[Model names]

[Service Ref.]

PCFY-P40VKM-E

**PCFY-P40VKM-E
PCFY-P40VKM-ER1
PCFY-P40VKM-ER2**

PCFY-P63VKM-E

**PCFY-P63VKM-E
PCFY-P63VKM-ER1
PCFY-P63VKM-ER2**

PCFY-P100VKM-E

**PCFY-P100VKM-E
PCFY-P100VKM-ER1
PCFY-P100VKM-ER2**

PCFY-P125VKM-E

**PCFY-P125VKM-E
PCFY-P125VKM-ER1
PCFY-P125VKM-ER2**

Revision:

- PCFY-P40VKM-ER2,
PCFY-P63VKM-ER2,
PCFY-P100VKM-ER2 and
PCFY-P125VKM-ER2
have been added in
REVISED EDITION-C.

OCB449B is void.

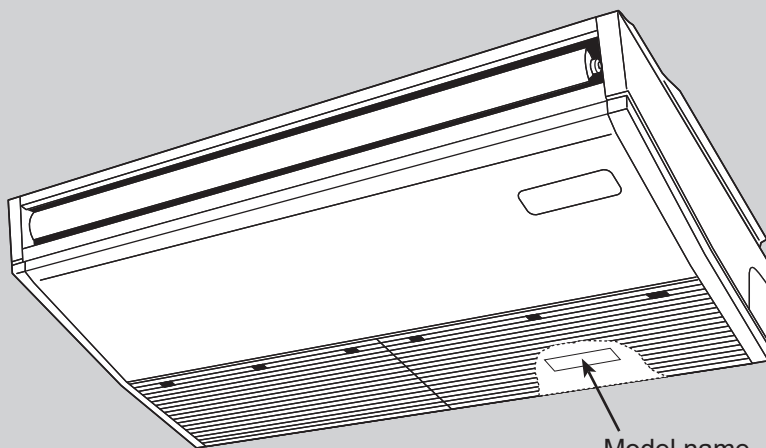

INDOOR UNIT

CONTENTS

1. SERVICE PARTS LIST 2
2. OPTIONAL PARTS 10

SERVICE MANUAL (OCH449)

1. The part quantity below indicates the required number of pieces per unit.
2. The circled No. indicates that the part is not shown in the figure.

No.	Part No.	Part Name	PCFY-P40V/KM-E	PCFY-P40V/KM-ER1	PCFY-P40V/KM-ER2	Wiring Diagram Symbol	Remarks [Drawing No.]
1	R01 E26 662	SIDE PANEL-L	1	1	1		Includes HANGER
2	R01 E06 809	LEG-L	1	1	1		
3	R01 E02 666	SIDE PLATE-L	1	1	1		Includes LEG-L
4	R01 E05 615	COIL SUPPORT-H	1	1	1		
5	R01 R55 480	HEAT EXCHANGER	1	1			
5	R01 C05 480	HEAT EXCHANGER			1		
6	R01 E12 651	FRONT PANEL-S	1	1	1		
7	R01 E28 002	AUTO VANE-S	1	1	1		
8	R01 E04 033	VANE SUPPORT	1	1	1		
9	R01 E04 615	COIL SUPPORT	1	1	1		
10	R01 E10 660	PIPE COVERS SET	1	1	1		
11	R01 E02 126	PIPE BAND	1	1	1		
12	T7W E61 202	THERMISTOR-L/G	1	1	1	TH22/TH23	
13	R01 H31 223	VANE MOTOR ASSY	1	1	1	MV	
14	R01 E45 661	SIDE PANEL-R	1	1	1		Includes HANGER
15	R01 E06 808	LEG-R	1	1	1		
16	R01 E02 665	SIDE PLATE-R	1	1	1		Includes LEG-R
17	R01 E03 085	GUIDE VANE (5)	2	2	2		
18	R01 E42 529	DRAIN PAN (S)	1	1	1		
19	R01 18J 523	JOINT SOCKET	1	1	1		VP20
20	R01 18J 072	DRAIN HOSE COVER	1	1	1		
21	R01 18J 524	DRAIN PLUG	1	1	1		
22	R01 E03 660	DRAIN SOCKET COVER	1	1	1		
23	R01 E03 669	UNDER PANEL-S	1	1	1		
24	R01 E03 070	BRAND PLATE	1	1	1		
25	R01 E00 053	PIPE HOLE COVER	1	1	1		
26	-	BASE	1	1	1		Includes REAR PANEL [RG00V682G57]
27	-	FAN PLATE	1	1	1		[RG00V683G66]
28	-	BEAM	1	1	1		[RG00D440G02]
29	R01 20J 110	CASING (UNDER & TOP)	2	2	2		UNDER & TOP
30	R01 E40 114	SIROCCO FAN (AL12)	2	2	2		BOSS ø12
31	T7W C04 220	FAN MOTOR	1	1	1	MF	
32	T7W E16 130	MOTOR LEG	1	1	1		
33	T7W E02 126	PIECE (R.L)	1	1	1		LEFT & RIGHT
34	T7W E20 675	FAN GUARD-L	1	1	1		
35	T7W E21 675	FAN GUARD-R	1	1	1		
36	T7W E22 675	FAN GUARD	1	1	1		FOR MF
37	R01 E24 500	AIR FILTER-S	2	2	2		
38	R01 E54 691	GRILLE-S	2	2	2		Includes HANGER
39	R01 E04 061	GRILLE HINGE	4	4	4		
40	R01 E11 054	GRILLE CATCH	4	4	4		
41	R01 H04 401	LEV-4/EFM	1	1	1	LEV	

PCFY-P63VKM-E
 PCFY-P63VKM-ER1
 PCFY-P63VKM-ER2

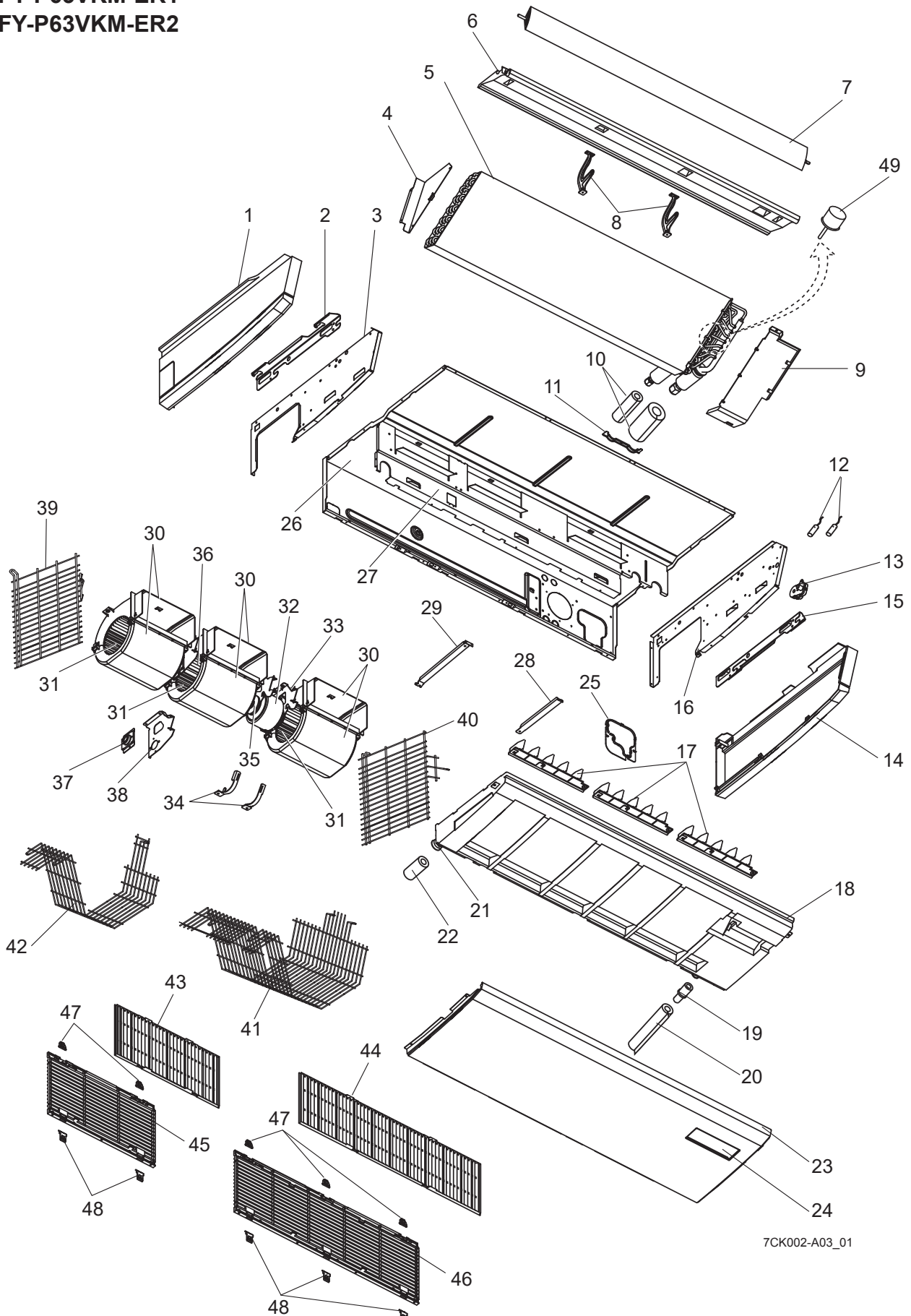

7CK002-A03_01

1. The part quantity below indicates the required number of pieces per unit.
2. The circled No. indicates that the part is not shown in the figure.

No.	Part No.	Part Name	PCFY-P63VKM-E	PCFY-P63VKM-ER1	PCFY-P63VKM-ER2	Wiring Diagram Symbol	Remarks [Drawing No.]
1	R01 E26 662	SIDE PANEL-L	1	1	1		Includes HANGER
2	R01 E06 809	LEG-L	1	1	1		
3	R01 E02 666	SIDE PLATE-L	1	1	1		Includes LEG-L
4	R01 E05 615	COIL SUPPORT-H	1	1	1		
5	R01 R56 480	HEAT EXCHANGER	1	1			
5	R01 C06 480	HEAT EXCHANGER			1		
6	R01 E13 651	FRONT PANEL-M	1	1	1		
7	R01 E29 002	AUTO VANE-M	1	1	1		
8	R01 E04 033	VANE SUPPORT	2	2	2		
9	R01 E04 615	COIL SUPPORT	1	1	1		
10	R01 E10 660	PIPE COVERS SET	1	1	1		
11	R01 E02 126	PIPE BAND	1	1	1		
12	T7W E61 202	THERMISTOR-L/G	1	1	1	TH22/TH23	
13	R01 H31 223	VANE MOTOR ASSY	1	1	1	MV	
14	R01 E45 661	SIDE PANEL-R	1	1	1		Includes HANGER
15	R01 E06 808	LEG-R	1	1	1		
16	R01 E02 665	SIDE PLATE-R	1	1	1		Includes LEG-R
17	R01 E03 085	GUIDE VANE (5)	3	3	3		
18	R01 E43 529	DRAIN PAN (M)	1	1	1		
19	R01 18J 523	JOINT SOCKET	1	1	1		VP20
20	R01 18J 072	DRAIN HOSE COVER	1	1	1		
21	R01 18J 524	DRAIN PLUG	1	1	1		
22	R01 E03 660	DRAIN SOCKET COVER	1	1	1		
23	R01 E04 669	UNDER PANEL-M	1	1	1		
24	R01 E03 070	BRAND PLATE	1	1	1		
25	R01 E00 053	PIPE HOLE COVER	1	1	1		
26	-	BASE	1	1	1		Includes REAR PANEL [RG00V682G58]
27	-	FAN PLATE	1	1	1		[RG00V683G67]
28	-	BEAM	1	1	1		[RG00D440G02]
29	-	BEAM	1	1	1		[BH02G431G10]
30	R01 20J 110	CASING (UNDER & TOP)	3	3	3		UNDER & TOP
31	R01 E40 114	SIROCCO FAN (AL12)	3	3	3		BOSS ϕ 12
32	T7W C05 220	FAN MOTOR	1	1	1	MF	
33	T7W E16 130	MOTOR LEG	1	1	1		
34	T7W E02 126	PIECE (R.L)	1	1	1		LEFT & RIGHT
35	R01 H00 116	JOINT (SHAFT)	1	1	1		
36	R01 31J 100	FAN SHAFT	1	1	1		
37	R01 E05 103	BEARING	1	1	1		OIL SET
38	R01 E00 145	BEARING SUPPORT	1	1	1		
39	T7W E20 675	FAN GUARD-L	1	1	1		
40	T7W E21 675	FAN GUARD-R	1	1	1		
41	T7W E23 675	FAN GUARD	1	1	1		FOR MF
42	T7W E24 675	FAN GUARD	1	1	1		
43	R01 E24 500	AIR FILTER-S	1	1	1		
44	R01 E25 500	AIR FILTER-L	1	1	1		
45	R01 E54 691	GRILLE-S	1	1	1		Includes HANGER
46	R01 E55 691	GRILLE-L	1	1	1		Includes HANGER
47	R01 E04 061	GRILLE HINGE	5	5	5		
48	R01 E11 054	GRILLE CATCH	5	5	5		
49	R01 H04 401	LEV-4/EFM	1	1	1	LEV	

PCFY-P100VKM-E
PCFY-P125VKM-E
PCFY-P100VKM-ER1
PCFY-P125VKM-ER1
PCFY-P100VKM-ER2
PCFY-P125VKM-ER2

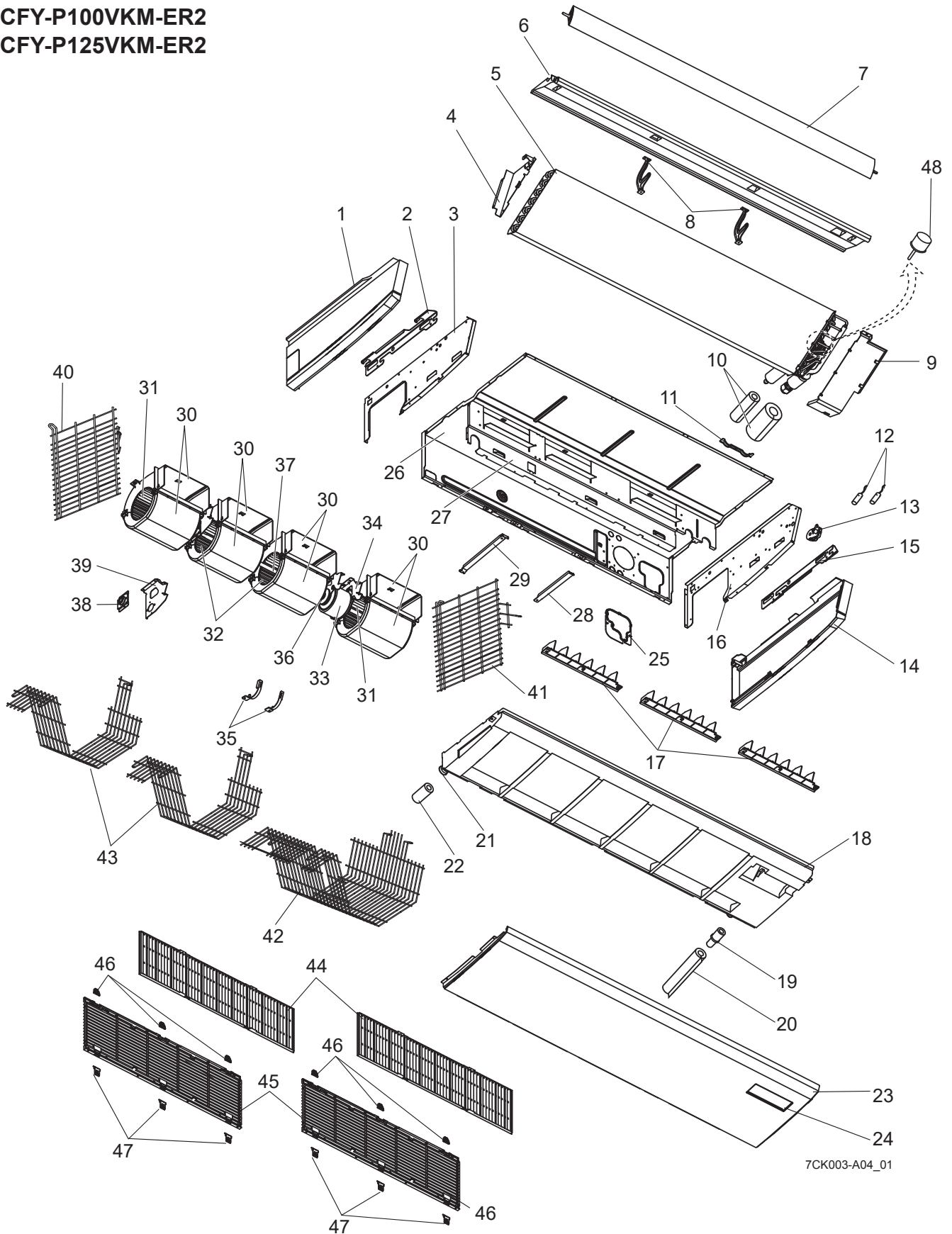

7CK003-A04_01

1. The part quantity below indicates the required number of pieces per unit.
2. The circled No. indicates that the part is not shown in the figure.

No.	Part No.	Part Name							Wiring Diagram Symbol	Remarks [Drawing No.]
			PCFY-P100VKM-E	PCFY-P125VKM-E	PCFY-P100VKM-ER1	PCFY-P125VKM-ER1	PCFY-P100VKM-ER2	PCFY-P125VKM-ER2		
1	R01 E26 662	SIDE PANEL-L	1	1	1	1	1	1		Includes HANGER
2	R01 E06 809	LEG-L	1	1	1	1	1	1		
3	R01 E02 666	SIDE PLATE-L	1	1	1	1	1	1		Includes LEG-L
4	R01 E08 615	COIL SUPPORT-H	1	1	1	1	1	1		
5	R01 R58 480	HEAT EXCHANGER	1		1					
5	R01 R59 480	HEAT EXCHANGER		1		1				
5	R01 C11 480	HEAT EXCHANGER					1			
5	R01 C12 480	HEAT EXCHANGER						1		
6	R01 E14 651	FRONT PANEL-L	1	1	1	1	1	1		
7	R01 E30 002	AUTO VANE-L	1	1	1	1	1	1		
8	R01 E04 033	VANE SUPPORT	2	2	2	2	2	2		
9	R01 E04 615	COIL SUPPORT	1	1	1	1	1	1		
10	R01 E10 660	PIPE COVERS SET	1	1	1	1	1	1		
11	R01 E02 126	PIPE BAND	1	1	1	1	1	1		
12	T7W E61 202	THERMISTOR-L/G	1	1	1	1	1	1	TH22/TH23	
13	R01 H31 223	VANE MOTOR ASSY	1	1	1	1	1	1	MV	
14	R01 E45 661	SIDE PANEL-R	1	1	1	1	1	1		Includes HANGER
15	R01 E06 808	LEG-R	1	1	1	1	1	1		
16	R01 E02 665	SIDE PLATE-R	1	1	1	1	1	1		Includes LEG-R
17	R01 E04 085	GUIDE VANE (6)	3	3	3	3	3	3		
18	R01 E44 529	DRAIN PAN (L)	1	1	1	1	1	1		
19	R01 18J 523	JOINT SOCKET	1	1	1	1	1	1		VP20
20	R01 18J 072	DRAIN HOSE COVER	1	1	1	1	1	1		
21	R01 18J 524	DRAIN PLUG	1	1	1	1	1	1		
22	R01 E03 660	DRAIN SOCKET COVER	1	1	1	1	1	1		
23	R01 E05 669	UNDER PANEL-L	1	1	1	1	1	1		
24	R01 E03 070	BRAND PLATE	1	1	1	1	1	1		
25	R01 E00 053	PIPE HOLE COVER	1	1	1	1	1	1		
26	-	BASE	1	1	1	1	1	1		Includes REAR PANEL [RG00V682G61]
27	-	FAN PLATE	1	1	1	1	1	1		[RG00V683G70]
28	-	BEAM	1	1	1	1	1	1		[RG00D440G02]
29	-	BEAM	1	1	1	1	1	1		[BH02G431G10]
30	R01 20J 110	CASING (UNDER&TOP)	4	4	4	4	4	4		UNDER & TOP
31	R01 E40 114	SIROCCO FAN (AL12)	2	2	2	2	2	2		BOSS ø12
32	R01 E41 114	SIROCCO FAN (AL15)	2	2	2	2	2	2		BOSS ø15
33	T7W C06 220	FAN MOTOR	1	1	1	1	1	1	MF	
34	T7W E16 130	MOTOR LEG	1	1	1	1	1	1		
35	T7W E02 126	PIECE (R.L)	1	1	1	1	1	1		LEFT & RIGHT
36	R01 H00 116	JOINT (SHAFT)	1	1	1	1	1	1		
37	R01 32J 100	FAN SHAFT	1	1	1	1	1	1		
38	R01 E05 103	BEARING	1	1	1	1	1	1		OIL SET
39	R01 E00 145	BEARING SUPPORT	1	1	1	1	1	1		
40	T7W E20 675	FAN GUARD-L	1	1	1	1	1	1		
41	T7W E21 675	FAN GUARD-R	1	1	1	1	1	1		
42	T7W E23 675	FAN GUARD	1	1	1	1	1	1		FOR MF
43	T7W E25 675	FAN GUARD	2	2	2	2	2	2		
44	R01 E25 500	AIR FILTER-L	2	2	2	2	2	2		
45	R01 E55 691	GRILLE-L	2	2	2	2	2	2		Includes HANGER
46	R01 E04 061	GRILLE HINGE	6	6	6	6	6	6		
47	R01 E11 054	GRILLE CATCH	6	6	6	6	6	6		
48	R01 H24 401	LEV-8/EFM	1	1	1	1	1	1	LEV	

ELECTRICAL PARTS

PCFY-P40VKM-E

PCFY-P63VKM-E

PCFY-P100VKM-E

PCFY-P125VKM-E

PCFY-P40VKM-ER1

PCFY-P63VKM-ER1

PCFY-P100VKM-ER1

PCFY-P125VKM-ER1

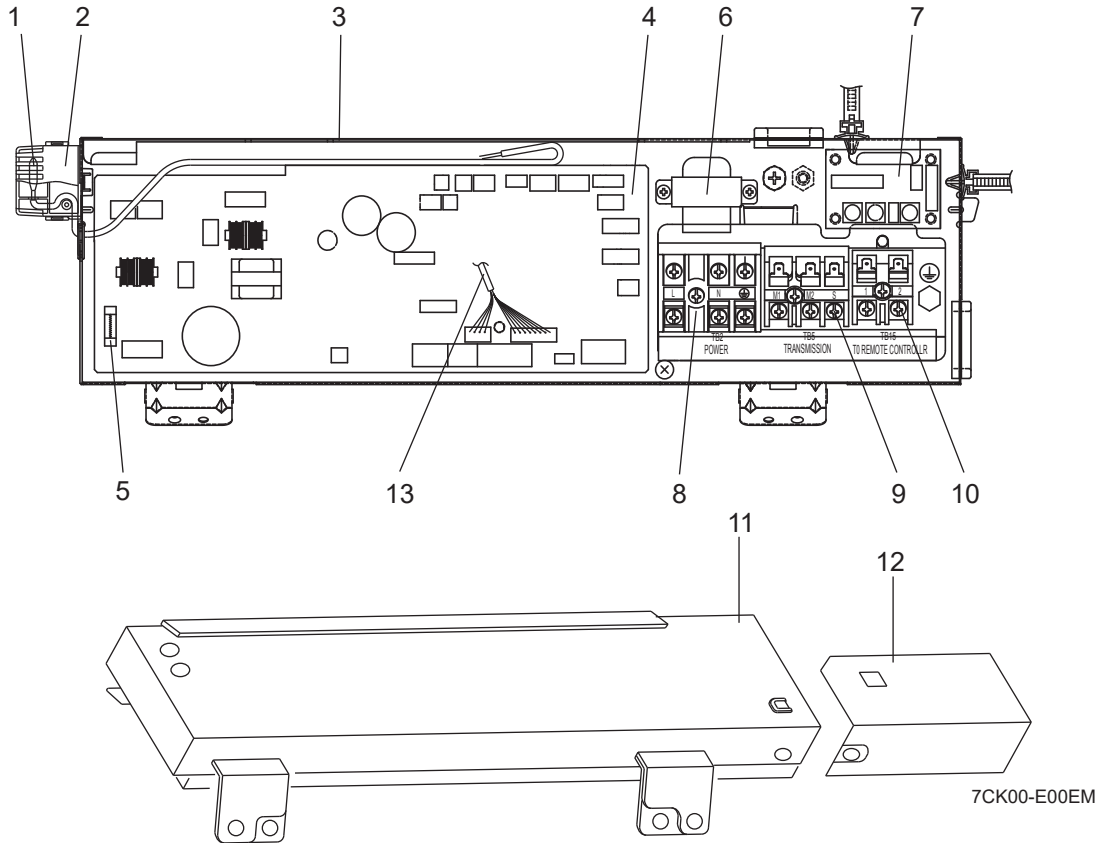

No.	Part No.	Part Name									Wiring Diagram Symbol	Remarks [Drawing No.]
			PCFY-P40VKM-E	PCFY-P40VKM-ER1	PCFY-P63VKM-E	PCFY-P63VKM-ER1	PCFY-P100VKM-E	PCFY-P100VKM-ER1	PCFY-P125VKM-E	PCFY-P125VKM-ER1		
1	R01 N18 202	THERMISTOR (ROOM)	1	1	1	1	1	1	1	1	TH21	
2	R01 E01 520	SENSOR COVER	1	1	1	1	1	1	1	1		For TH21
3	-	ELECTRICAL BOX	1	1	1	1	1	1	1	1		[BH00G997G31]
4	T7W E81 310	CONTROLLER BOARD	1		1		1		1		I.B	
4	T7W C08 310	CONTROLLER BOARD		1		1		1		1	I.B	
5	R01 E06 239	FUSE 6.3A 250V	1	1	1	1	1	1	1	1	FUSE	6.3A 250V
6	T7W E19 259	REACTOR	1	1	1	1	1	1	1	1	DCL	
7	T7W E01 294	ADDRESS BOARD	1	1	1	1	1	1	1	1	A.B	
8	T7W P02 246	T.B./ L.N.E	1	1	1	1	1	1	1	1	TB2	3P (L, N, ⊕)
9	T7W S02 246	T.B./ M1.M2.S	1	1	1	1	1	1	1	1	TB5	3P (M1,M2,S)
10	R01 E44 246	T.B./ 1.2	1	1	1	1	1	1	1	1	TB15	2P (1,2)
11	-	ELECTRICAL BOX COVER	1	1	1	1	1	1	1	1		[BH00L104G09]
12	-	ELECTRICAL BOX COVER	1	1	1	1	1	1	1	1		[RG02V755G02]
13	R01 E09 305	CABLE (A.B - I.B)	1	1	1	1	1	1	1	1		

ELECTRICAL PARTS

PCFY-P40VKM-ER2 PCFY-P63VKM-ER2 PCFY-P100VKM-ER2 PCFY-P125VKM-ER2

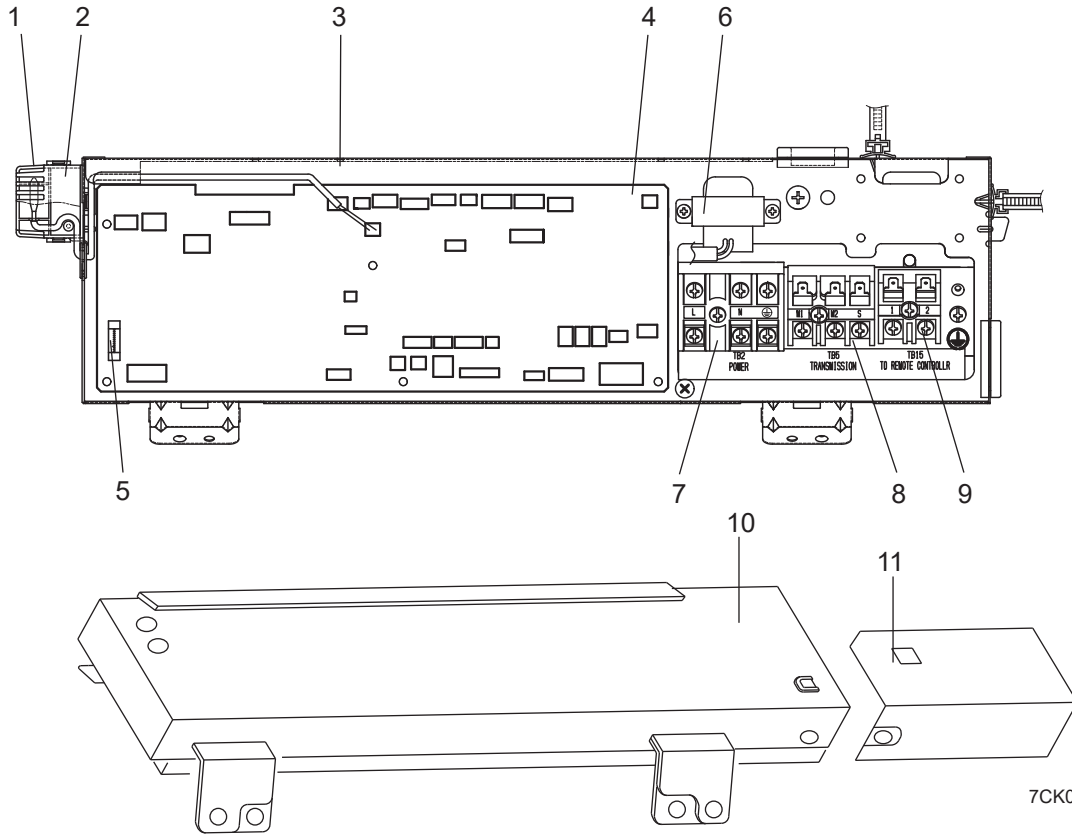

No.	Part No.	Part Name	PCFY-P40VKM-ER2	PCFY-P63VKM-ER2	PCFY-P100VKM-ER2	PCFY-P125VKM-ER2	Wiring Diagram Symbol	Remarks [Drawing No.]
1	R01 H18 202	THERMISTOR (ROOM)	1	1	1	1	TH21	
2	R01 E01 520	SENSOR COVER	1	1	1	1		For TH21
3	-	ELECTRICAL BOX	1	1	1	1		[BH00G997G35]
4	T7W M08 310	CONTROLLER BOARD	1	1	1	1	I.B	
5	R01 E14 239	FUSE 6.3A 250V	1	1	1	1	FUSE	6.3A 250V
6	T7W E19 259	REACTOR	1	1	1	1	DCL	
7	T7W P02 246	T.B./ L.N.E	1	1	1	1	TB2	3P (L, N, ⊕)
8	T7W S02 246	T.B./ M1.M2.S	1	1	1	1	TB5	3P (M1,M2,S)
9	R01 E44 246	T.B./ 1.2	1	1	1	1	TB15	2P (1,2)
10	-	ELECTRICAL BOX COVER	1	1	1	1		[BH00L104G09]
11	-	ELECTRICAL BOX COVER	1	1	1	1		[RG02V755G02]

2**OPTIONAL PARTS**

Parts name	Parts No.
WIRELESS REMOTE CONTROLLER	PAR-SL94B-E
WIRED REMOTE CONTROLLER (MA REMOTE CONTROLLER)	PAR-41MAA
WIRED REMOTE CONTROLLER (ME REMOTE CONTROLLER)	PAR-U02MEDA
DRAIN LIFT UP MECHANISM	PAC-SJ92DM-E *1 PAC-SJ93DM-E *2
HIGH EFFICIENCY FILTER	PAC-SH88KF-E *3 PAC-SH89KF-E *4 PAC-SH90KF-E *5

*1 PCFY-P40VKM-E only.

*2 PCFY-P63,100,125VKM-E only.

*3 PCFY-P40VKM-E only.

*4 PCFY-P63VKM-E only.

*5 PCFY-P100,125VKM-E only

mitsubishi electric corporation

HEAD OFFICE: TOKYO BUILDING, 2-7-3, MARUNOUCHI, CHIYODA-KU, TOKYO 100-8310, JAPAN