

TECHNICAL & SERVICE MANUAL

Series PCFY Ceiling Suspended R32

Indoor unit [Model names]	[Service Ref.]
PCFY-MS40VKM-E	PCFY-MS40VKM-E
PCFY-MS40VKM-ET	PCFY-MS40VKM-ET
PCFY-MS63VKM-E	PCFY-MS63VKM-E
PCFY-MS63VKM-ET	PCFY-MS63VKM-ET
PCFY-MS100VKM-E	PCFY-MS100VKM-E
PCFY-MS100VKM-ET	PCFY-MS100VKM-ET
PCFY-MS125VKM-E	PCFY-MS125VKM-E
PCFY-MS125VKM-ET	PCFY-MS125VKM-ET

Note:

- This manual describes only service data of the indoor units.

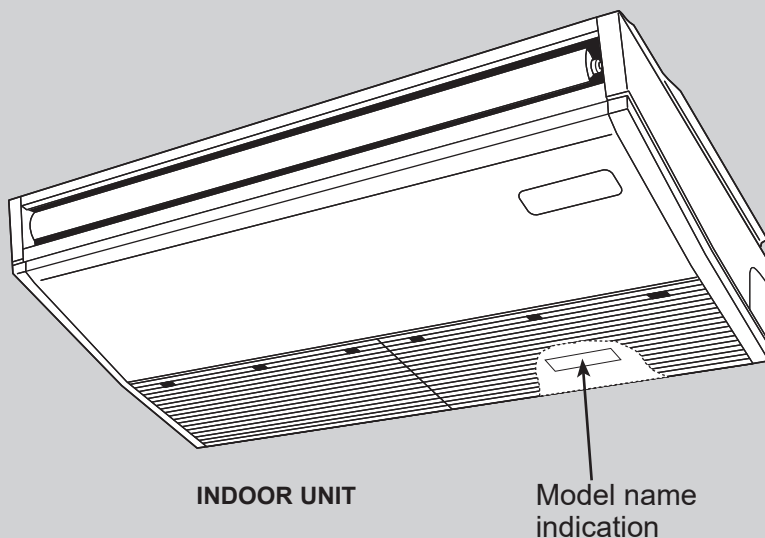





CONTENTS

1. SAFETY PRECAUTION	2
2. PART NAMES AND FUNCTIONS	8
3. SPECIFICATION	9
4. OUTLINES AND DIMENSIONS	13
5. WIRING DIAGRAM	16
6. REFRIGERANT SYSTEM DIAGRAM ...	17
7. TROUBLESHOOTING	18
8. DISASSEMBLY PROCEDURE	27
9. REMOTE CONTROLLER	33

PARTS CATALOG (OCB820)

CITY MULTI

MEANINGS OF SYMBOLS DISPLAYED ON THE UNIT

	WARNING (Risk of fire)	This mark is for R32 refrigerant only. Refrigerant type is written on nameplate of outdoor unit. In case that refrigerant type is R32, this unit uses a flammable refrigerant. If refrigerant leaks and comes in contact with fire or heating part, it will create harmful gas and there is risk of fire.
	Read the OPERATION MANUAL carefully before operation.	
	Service personnel are required to carefully read the OPERATION MANUAL and INSTALLATION MANUAL before operation.	
	Further information is available in the OPERATION MANUAL, INSTALLATION MANUAL, and the like.	

1-1. ALWAYS OBSERVE FOR SAFETY

Before obtaining access to terminal, all supply circuits must be disconnected.

1-2. CAUTIONS RELATED TO REFRIGERANT

Caution for units utilizing refrigerant R32

Use new refrigerant pipe.

In case of using the existing pipes for R22, be careful with the following.

- Be sure to clean the pipes and make sure that the insides of the pipes are clean.
- Change flare nut to the one provided with this product.
Use a newly flared pipe.
- Avoid using thin pipes.
- In case of reconnecting the refrigerant pipes after detaching, make the flared part of pipe re-fabricated.

Make sure that the inside and outside of refrigerant piping is clean and it has no contaminants such as sulfur, oxides, dirt, shaving particles, etc, which are hazard to refrigerant cycle. In addition, use pipes with specified thickness.

Contamination inside refrigerant piping can cause deterioration of refrigerant oil, etc.

Store the piping indoors, and both ends of the piping sealed until just before brazing. (Leave elbow joints, etc. in their packaging.)

If dirt, dust or moisture enters into refrigerant cycle, that can cause deterioration of refrigerant oil or malfunction of compressor.

The refrigerant oil applied to flare and flange connections must be ester oil, ether oil or alkylbenzene oil in a small amount.

If large amount of mineral oil enters, that can cause deterioration of refrigerant oil etc.

Charge refrigerant from liquid phase of gas cylinder.

If the refrigerant is charged from gas phase, composition change may occur in refrigerant and the efficiency will be lowered.

Use a vacuum pump with a reverse flow check valve.

Vacuum pump oil may flow back into refrigerant cycle and that can cause deterioration of refrigerant oil etc.

Use the following tools specifically designed for use with R32 refrigerant.

The following tools are necessary to use R32 refrigerant.

Tools for R32	
Gauge manifold	Flare tool
Charge hose	Size adjustment gauge
Gas leak detector	Vacuum pump adaptor
Torque wrench	Electronic refrigerant charging scale

Handle tools with care.

If dirt, dust or moisture enters into refrigerant cycle, that can cause deterioration of refrigerant oil or malfunction of compressor.

Do not use a charging cylinder.

If a charging cylinder is used, the composition of refrigerant will change and the efficiency will be lowered.

Use the specified refrigerant only.

Never use any refrigerant other than that specified.

Doing so may cause a burst, an explosion, or fire when the unit is being used, serviced, or disposed of.
Correct refrigerant is specified on name plate of outdoor unit.

If other refrigerant (R22, etc.) is used, chlorine in refrigerant can cause deterioration of refrigerant oil, etc.
We will not be held responsible for mechanical failure, system malfunction, unit breakdown or accidents caused by failure to follow the instructions.

Ventilate the room if refrigerant leaks during operation. If refrigerant comes into contact with a flame, poisonous gases will be released.

[1] Warning for service

- (1) Do not alter the unit.
- (2) For installation and relocation work, follow the instructions in the Installation Manual and use tools and pipe components specifically made for use with refrigerant specified in the outdoor unit installation manual.
- (3) Ask a dealer or an authorized technician to install, relocate and repair the unit.
- (4) This unit should be installed in rooms which exceed the floor space specified in outdoor unit installation manual. Refer to outdoor unit installation manual.
- (5) Install the indoor unit at least 2.5 m above floor or grade level.
For appliances not accessible to the general public.
- (6) Refrigerant pipes connection shall be accessible for maintenance purposes.
- (7) If the air conditioner is installed in a small room or closed room, measures must be taken to prevent the refrigerant concentration in the room from exceeding the safety limit in the event of refrigerant leakage. Should the refrigerant leak and cause the concentration limit to be exceeded, hazards due to lack of oxygen in the room may result.
- (8) Keep gas-burning appliances, electric heaters, and other fire sources (ignition sources) away from the location where installation, repair, and other air conditioner work will be performed.
If refrigerant comes into contact with a flame, poisonous gases will be released.
- (9) When installing or relocating, or servicing the air conditioner, use only the specified refrigerant written on outdoor unit to charge the refrigerant lines.
Do not mix it with any other refrigerant and do not allow air to remain in the lines.
If air is mixed with the refrigerant, then it can be the cause of abnormal high pressure in the refrigerant line, and may result in an explosion and other hazards.
- (10) After installation has been completed, check for refrigerant leaks. If refrigerant leaks into the room and comes into contact with the flame of a heater or portable cooking range, poisonous gases will be released.
- (11) Do not use low temperature solder alloy in case of brazing the refrigerant pipes.
- (12) When performing brazing work, be sure to ventilate the room sufficiently. Make sure that there are no hazardous or flammable materials nearby.
When performing the work in a closed room, small room, or similar location, make sure that there are no refrigerant leaks before performing the work.
If refrigerant leaks and accumulates, it may ignite or poisonous gases may be released.
- (13) Do not install the unit in places where refrigerant may build-up or places with poor ventilation such as a semi-basement or a sunken place in outdoor: Refrigerant is heavier than air, and inclined to fall away from the leak source.
- (14) Do not use means to accelerate the defrosting process or to clean, other than those recommended by the manufacturer.
- (15) The appliance shall be stored in a room without continuously operating ignition sources (for example: open flames, an operating gas appliance or an operating electric heater).
- (16) Do not pierce or burn.
- (17) Be aware that refrigerants may not contain an odour.
- (18) Pipe-work shall be protected from physical damage.
- (19) The installation of pipe-work shall be kept to a minimum.
- (20) Compliance with national gas regulations shall be observed.
- (21) Keep any required ventilation openings clear of obstruction.
- (22) Servicing shall be performed only as recommended by the manufacturer.
- (23) The appliance shall be stored in a well-ventilated area where the room size corresponds to the room area as specified for operation.
- (24) Maintenance, service and repair operations shall be performed by authorized technician with required qualification.

[2] Cautions for service

- (1) Perform service after recovering the refrigerant left in unit completely.
- (2) Do not release refrigerant in the air.
- (3) After completing service, charge the cycle with specified amount of refrigerant.
- (4) When performing service, install a filter drier simultaneously.
Be sure to use a filter drier for new refrigerant.

[3] Additional refrigerant charge

When charging directly from cylinder

- (1) Check that cylinder for R32/R410A available on the market is a syphon type.
- (2) Charging should be performed with the cylinder of syphon stood vertically. (Refrigerant is charged from liquid phase.)

[4] Cautions for unit using R32 refrigerant

Basic work procedures are the same as those for conventional units using refrigerant R410A. However, pay careful attention to the following points.

(1) Information on servicing

(1-1) Checks on the Area

Prior to beginning work on systems containing flammable refrigerants, safety checks are necessary to ensure that the risk of ignition is minimized.

For repair to the refrigerating systems, (1-3) to (1-7) shall be completed prior to conducting work on the systems.

(1-2) Work Procedure

Work shall be undertaken under a controlled procedure so as to minimize the risk of a flammable gas or vapor being present while the work is being performed.

(1-3) General Work Area

All maintenance staff and others working in the local area shall be instructed on the nature of work being carried out.

Work in confined spaces shall be avoided. The area around the workspace shall be sectioned off. Ensure that the conditions within the area have been made safe by control of flammable material.

(1-4) Checking for Presence of Refrigerant

The area shall be checked with an appropriate refrigerant detector prior to and during work, to ensure the technician is aware of potentially toxic or flammable atmospheres. Ensure that the leak detection equipment being used is suitable for use with all applicable refrigerants, i.e. non-sparking, adequately sealed or intrinsically safe.

(1-5) Presence of Fire Extinguisher

If any hot work is to be conducted on the refrigeration equipment or any associated parts, appropriate fire extinguishing equipment shall be available to hand.

Have a dry powder or CO2 fire extinguisher adjacent to the charging area.

(1-6) No Ignition Sources

No person carrying out work in relation to a refrigeration system which involves exposing any pipe work shall use any sources of ignition in such a manner that it may lead to the risk of fire or explosion. All possible ignition sources, including cigarette smoking, should be kept sufficiently far away from the site of installation, repairing, removing and disposal, during which refrigerant can possibly be released to the surrounding space. Prior to work taking place, the area around the equipment is to be surveyed to make sure that there are no flammable hazards or ignition risks. "No Smoking" signs shall be displayed.

(1-7) Ventilated Area

Ensure that the area is in the open or that it is adequately ventilated before breaking into the system or conducting any hot work. A degree of ventilation shall continue during the period that the work is carried out. The ventilation should safely disperse any released refrigerant and preferably expel it externally into the atmosphere.

(1-8) Checks on the Refrigeration Equipment

Where electrical components are being changed, they shall be fit for the purpose and to the correct specification. At all times the manufacturer's maintenance and service guidelines shall be followed. If in doubt, consult the manufacturer's technical department for assistance.

The following checks shall be applied to installations using flammable refrigerants:

- The charge size is in accordance with the room size within which the refrigerant containing parts are installed.
- The ventilation machinery and outlets are operating adequately and are not obstructed.
- Marking to the equipment continues to be visible and legible. Markings and signs that are illegible shall be corrected.
- Refrigeration pipe or components are installed in a position where they are unlikely to be exposed to any substance which may corrode refrigerant containing components, unless the components are constructed of materials which are inherently resistant to being corroded or are suitably protected against being corroded.

(1-9) Checks on Electrical Devices

Repair and maintenance to electrical components shall include initial safety checks and component inspection procedures. If a fault exists that could compromise safety, then no electrical supply shall be connected to the circuit until it is satisfactorily dealt with. If the fault cannot be corrected immediately but it is necessary to continue operation, an adequate temporary solution shall be used. This shall be reported to the owner of the equipment so all parties are advised. Initial safety checks shall include that:

- capacitors are discharged: this shall be done in a safe manner to avoid possibility of sparking;
- no live electrical components and wiring are exposed while charging, recovering or purging the system;
- there is continuity of earth bonding

(2) Repairs to Sealed Components

(2-1) During repairs to sealed components, all electrical supplies shall be disconnected from the equipment being worked upon prior to any removal of sealed covers, etc. If it is absolutely necessary to have an electrical supply to equipment during servicing, then a permanently operating form of leak detection shall be located at the most critical point to warn of a potentially hazardous situation.

(2-2) Particular attention shall be paid to the following to ensure that by working on electrical components, the casing is not altered in such a way that the level of protection is affected. This shall include damage to cables, excessive number of connections, terminals not made to original specification, damage to seals, incorrect fitting of glands, etc.

Ensure that the apparatus is mounted securely.

Ensure that seals or sealing materials have not degraded to the point that they no longer serve the purpose of preventing the ingress of flammable atmospheres.

Replacement parts shall be in accordance with the manufacturer's specifications.

(3) Repair to Inherently Safe Components

Do not apply any permanent inductive or capacitance loads to the circuit without ensuring that this will not exceed the permissible voltage and current permitted for the equipment in use.

Inherently safe components are the only types that can be worked on while live in the presence of a flammable atmosphere. The test apparatus shall be at the correct rating.

Replace components only with parts specified by the manufacturer. Other parts may result in the ignition of refrigerant in the atmosphere from a leak.

(4) Cabling

Check that cabling will not be subject to wear, corrosion, excessive pressure, vibration, sharp edges or any other adverse environmental effects. The check shall also take into account the effects of aging or continual vibration from sources such as compressors or fans.

(5) Detection of Flammable Refrigerants

Under no circumstances shall potential sources of ignition be used in the searching for or detection of refrigerant leaks. A halide torch (or any other detector using a naked flame) shall not be used.

(6) Leak Detection Methods

Electronic leak detectors may be used to detect refrigerant leaks but, in the case of flammable refrigerants, the sensitivity may not be adequate, or may need re-calibration. (Detection equipment shall be calibrated in a refrigerant-free area.)

Ensure that the detector is not a potential source of ignition and is suitable for the refrigerant used. Leak detection equipment shall be set at a percentage of the LFL of the refrigerant and shall be calibrated to the refrigerant employed, and the appropriate percentage of gas (25% maximum) is confirmed.

Leak detection fluids are suitable for use with most refrigerants but the use of detergents containing chlorine shall be avoided as the chlorine may react with the refrigerant and corrode the copper pipe-work.

If a leak is suspected, all naked flames shall be removed/extinguished.

If a leakage of refrigerant is found which requires brazing, all of the refrigerant shall be recovered from the system, or isolated (by means of shut off valves) in a part of the system remote from the leak. For appliances containing flammable refrigerants, oxygen free nitrogen (OFN) shall then be purged through the system both before and during the brazing process.

(7) Removal and Evacuation

When breaking into the refrigerant circuit to make repairs – or for any other purpose conventional procedures shall be used. However, for flammable refrigerants it is important that best practice is followed since flammability is a consideration. The following procedure shall be adhered to:

- remove refrigerant
- purge the circuit with inert gas
- evacuate
- purge again with inert gas
- open the circuit by cutting or brazing.

The refrigerant charge shall be recovered into the correct recovery cylinders. For appliances containing flammable refrigerants, the system shall be “flushed” with OFN to render the unit safe. This process may need to be repeated several times.

Compressed air or oxygen shall not be used for purging refrigerant systems.

For appliances containing flammable refrigerants, flushing shall be achieved by breaking the vacuum in the system with OFN and continuing to fill until the working pressure is achieved, then venting to atmosphere, and finally pulling down to a vacuum. This process shall be repeated until no refrigerant is within the system. When the final OFN charge is used, the system shall be vented down to atmospheric pressure to enable work to take place. This operation is absolutely vital if brazing operations on the pipe-work are to take place.

Ensure that the outlet for the vacuum pump is not close to any ignition sources and that ventilation is available.

(8) Charging Procedures

In addition to conventional charging procedures, the following requirements shall be followed:

- Ensure that contamination of different refrigerants does not occur when using charging equipment. Hoses or lines shall be as short as possible to minimize the amount of refrigerant contained in them.
- Cylinders shall be kept upright.
- Ensure that the refrigeration system is earthed prior to charging the system with refrigerant.
- Label the system when charging is complete (if not already).
- Extreme care shall be taken not to overfill the refrigeration system.

Prior to recharging the system, it shall be pressure-tested with the appropriate purging gas. The system shall be leak-tested on completion of charging but prior to commissioning. A follow up leak test shall be carried out prior to leaving the site.

(9) Decommissioning

Before carrying out this procedure, it is essential that the technician is completely familiar with the equipment and all its detail. It is recommended good practice that all refrigerants are recovered safely. Prior to the task being carried out, an oil and refrigerant sample shall be taken in case analysis is required prior to re-use of reclaimed refrigerant. It is essential that electrical power is available before the task is commenced.

Continued to the next page

- a) Become familiar with the equipment and its operation.
- b) Isolate system electrically.
- c) Before attempting the procedure, ensure that:
 - mechanical handling equipment is available, if required, for handling refrigerant cylinders;
 - all personal protective equipment is available and being used correctly;
 - the recovery process is supervised at all times by a competent person;
 - recovery equipment and cylinders conform to the appropriate standards.
- d) Pump down refrigerant system, if possible.
- e) If a vacuum is not possible, make a manifold so that refrigerant can be removed from various parts of the system.
- f) Make sure that cylinder is situated on the scales before recovery takes place.
- g) Start the recovery machine and operate in accordance with manufacturer's instructions.
- h) Do not overfill cylinders. (No more than 80 % volume liquid charge).
- i) Do not exceed the maximum working pressure of the cylinder, even temporarily.
- j) When the cylinders have been filled correctly and the process completed, make sure that the cylinders and the equipment are removed from site promptly and all isolation valves on the equipment are closed off.
- k) Recovered refrigerant shall not be charged into another refrigeration system unless it has been cleaned and checked.

(10) Labelling

Equipment shall be labelled stating that it has been de-commissioned and emptied of refrigerant. The label shall be dated and signed. For appliances containing flammable refrigerants, ensure that there are labels on the equipment stating the equipment contains flammable refrigerant.

(11) Recovery

When removing refrigerant from a system, either for servicing or decommissioning, it is recommended good practice that all refrigerants are removed safely. When transferring refrigerant into cylinders, ensure that only appropriate refrigerant recovery cylinders are employed. Ensure that the correct number of cylinders for holding the total system charge are available. All cylinders to be used are designated for the recovered refrigerant and labelled for that refrigerant (i.e. special cylinders for the recovery of refrigerant). Cylinders shall be complete with pressure-relief valve and associated shut-off valves in good working order. Empty recovery cylinders are evacuated and, if possible, cooled before recovery occurs.

The recovery equipment shall be in good working order with a set of instructions concerning the equipment that is at hand and shall be suitable for the recovery of all appropriate refrigerants including, when applicable, flammable refrigerants. In addition, a set of calibrated weighing scales shall be available and in good working order. Hoses shall be complete with leak-free disconnect couplings and in good condition. Before using the recovery machine, check that it is in satisfactory working order, has been properly maintained and that any associated electrical components are sealed to prevent ignition in the event of a refrigerant release. Consult manufacturer if in doubt.

The recovered refrigerant shall be returned to the refrigerant supplier in the correct recovery cylinder, and the relevant waste transfer note arranged. Do not mix refrigerants in recovery units and especially not in cylinders. If compressors or compressor oils are to be removed, ensure that they have been evacuated to an acceptable level to make certain that flammable refrigerant does not remain within the lubricant. The evacuation process shall be carried out prior to returning the compressor to the suppliers. Only electric heating to the compressor body shall be employed to accelerate this process. When oil is drained from a system, it shall be carried out safely.

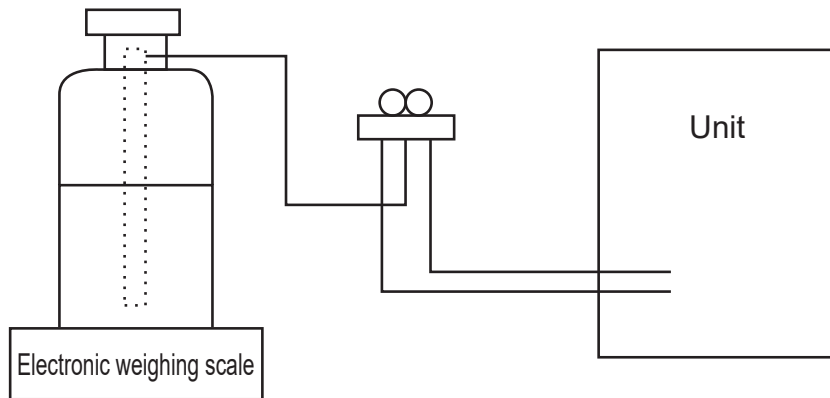

[5] Service tools

Use the below service tools as exclusive tools for R32 refrigerant.

Refer to the sepec name plate on outdoor unit for the type of refrigerant being used.

No.	Tool name	Specifications
1.	Gauge manifold	· Use the existing fitting specifications. (UNF1/2) · Use high-tension side pressure of 5.3MPa·G or over.
2.	Charge hose	· Use pressure performance of 5.09MPa·G or over.
3.	Electronic weighing scale	—
4.	Gas leak detector	· Use the detector for R134a, R407, R410A, or R32.
5.	Adaptor for reverse flow check	· Attach on vacuum pump.
6.	Refrigerant charge base	—
7.	Refrigerant cylinder	· R32 or R410A refrigerant · Cylinder with syphon
8.	Refrigerant recovery equipment	—

2-1. INDOOR UNIT

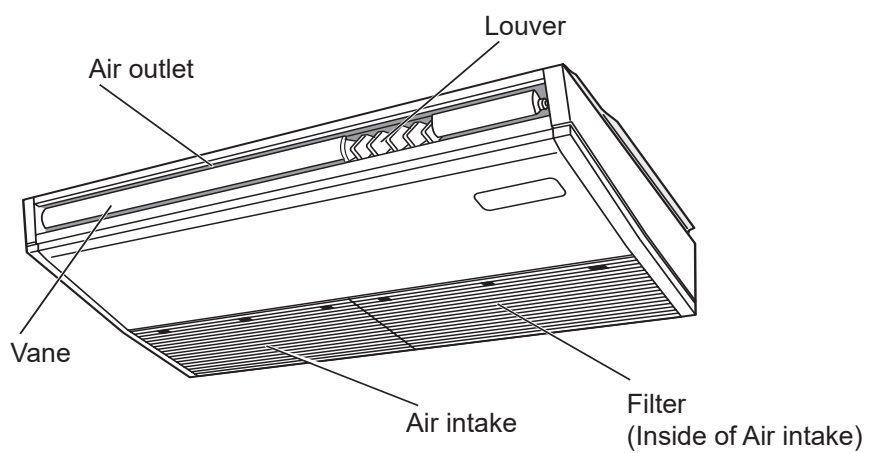

3-1. SPECIFICATIONS

Model		PCFY-MS40VKM-E/ET	PCFY-MS63VKM-E/ET	PCFY-MS100VKM-E/ET	PCFY-MS125VKM-E/ET	
Power source		1-phase 220-240V 50Hz, 1-phase 220V 60Hz				
Cooling capacity (Nominal)	*1 kW	4.5	7.1	11.2	14.0	
	*1 kcal/h	3,900	6,100	9,600	12,000	
	*1 Btu/h	15,400	24,200	38,200	47,800	
	*2 kcal/h	4,000	6,300	10,000	12,500	
	Power input	0.040	0.050	0.090	0.110	
Current input		A	0.28	0.33	0.65	0.76
Heating capacity (Nominal)	*3 kW	5.0	8.0	12.5	16.0	
	*3 kcal/h	4,300	6,900	10,800	13,800	
	*3 Btu/h	17,100	27,300	42,700	54,600	
	Power input	0.040	0.050	0.090	0.110	
	Current input		A	0.28	0.33	0.65
External finish		MUNSELL (6.4Y 8.9/0.4)				
External dimensions H x W x D		mm	230×960×680	230×1280×680	230×1600×680	
		in.	9-1/16×37-13/16×26-3/4	9-1/16×50-3/8×26-3/4	9-1/16×63×26-3/4	
Net weight		kg (lb)	25 (55)	32 (71)	37 (82)	39 (86)
Heat exchanger		Cross fin (Aluminum fin and copper tube)				
FAN	Type x quantity	Sirocco fan × 2	Sirocco fan × 3	Sirocco fan × 4		
	External static press.	Pa	0			
		mmH ₂ O	0			
	Motor type	DC motor				
	Motor output	kW	0.090	0.095	0.160	
	Driving mechanism	Direct-driven by motor				
	Airflow rate (Low-Mid2-Mid1-High)	m ³ /min	10-11-12-13	14-15-16-18	21-24-26-28	21-24-27-31
	L/s	167-183-200-217	233-250-267-300	350-400-433-467	350-400-450-517	
	cfm	353-388-424-459	494-530-565-636	742-847-918-989	742-847-953-1095	
Noise level (Low-Mid2-Mid1-High) (measured in anechoic room)		dB <A>	29-32-34-36	31-33-35-37	36-38-41-43	36-39-42-44
Insulation material		Polyeter sheet				
Air filter		PP honeycomb				
Protection device		Fuse				
Refrigerant control device		LEV (RH50B088H01) (PAM 4 ton)		LEV (RH50B089H01) (PAM 8 ton)		
Connectable outdoor unit		R32 CITY MULTI				
Diameter of refrigerant pipe	Liquid	mm(in)	ø6.35 (ø1/4) Flare	ø9.52 (ø3/8) Flare	ø9.52 (ø3/8) Flare	ø9.52 (ø3/8) Flare
	Gas	mm(in)	ø12.7 (ø1/2) Flare	ø15.88 (ø5/8) Flare	ø15.88 (ø5/8) Flare	ø15.88 (ø5/8) Flare
Field drain pipe size		mm(in)	O.D. 26mm (1)			
Standard attachment	Document	Installation Manual, Instruction Book				
	Accessory					
Optional parts	Drain pump kit	PAC-SJ92DM-E	PAC-SJ93DM-E			
	High efficiency filter	PAC-SH88KF-E	PAC-SH89KF-E	PAC-SH90KF-E		
	Wireless remote controller kit	PAR-FL32MA, PAR-SL101A-E				
Remarks	Installation	Details on foundation work, insulation work, electrical wiring, power source switch, and other items shall be referred to the Installation Manual.				
Note :		*1 Nominal cooling conditions	*2 Nominal cooling conditions	*3 Nominal heating conditions	Unit converter	
Indoor :		27°CDB/19°CWB (81°FDB/66°FWB)	27°CDB/19.5°CWB (81°FDB/67°FWB)	20°CDB (68°FDB)	kcal/h = kW × 860	
Outdoor :		35°CDB (95°FDB)	35°CDB (95°FDB)	7°CDB/6°CWB (45°FDB/43°FWB)	Btu/h = kW × 3,412	
Pipe length :		7.5 m (24-9/16 ft)	5 m (16-3/8 ft)	7.5 m (24-9/16 ft)	cfm = m ³ /min × 35.31	
Level difference :		0 m (0 ft)	0 m (0 ft)	0 m (0 ft)	lb = kg/0.4536	
* Nominal conditions *1, *3 are subject to JIS B8615-1.					*Above specification data is subject to rounding variation.	
* Due to continuing improvement, above specification may be subject to change without notice.						

3-2. ELECTRICAL PARTS SPECIFICATIONS

Service Ref.	Symbol	PCFY-MS40VKM-E PCFY-MS40VKM-ET	PCFY-MS63VKM-E PCFY-MS63VKM-ET	PCFY-MS100VKM-E PCFY-MS100VKM-ET PCFY-MS125VKM-E PCFY-MS125VKM-ET
Parts name				
Room temperature thermistor	TH21	Resistance 0°C/15 kΩ, 10°C/9.6 kΩ, 20°C/6.3 kΩ, 25°C/5.4 kΩ, 30°C/4.3 kΩ, 40°C/3.0 kΩ		
Liquid pipe thermistor	TH22	Resistance 0°C/15 kΩ, 10°C/9.6 kΩ, 20°C/6.3 kΩ, 25°C/5.4 kΩ, 30°C/4.3 kΩ, 40°C/3.0 kΩ		
Gas pipe thermistor	TH23	Resistance 0°C/15 kΩ, 10°C/9.6 kΩ, 20°C/6.3 kΩ, 25°C/5.4 kΩ, 30°C/4.3 kΩ, 40°C/3.0 kΩ		
Fuse (Indoor controller board)	FUSE	250 V 6.3 A		
Fan motor	MF	8-pole OUTPUT 90 W	8-pole OUTPUT 95 W	8-pole OUTPUT 160 W
Vane motor	MV	MSBPC20 DC12 V 300 Ω/phase		
Drain-pump (Option)	DP	INPUT 12/10.8 W 24ℓ /Hr		
Drain float switch (Option)	FS	Open / Short detection DC 5 V		
Linear expansion valve	LEV	DC12 V Stepping motor drive Port dimension ø3.2 (0~2000pulse) PAM-B40YGME	DC12 V Stepping motor drive Port dimension ø5.2 (0~2000pulse) PAM-B80YGME	
Power supply terminal block	TB2	(L, N, ⊕) Rated to 330 V 30 A *		
Transmission terminal block	TB5	(M1, M2, S) Rated to 250 V 20 A *		
MA remote controller terminal block	TB15	(1, 2) Rated to 250 V 10 A *		
Refrigerant sensor	RS	DC 5 V		

* Refer to WIRING DIAGRAM for the supplied voltage.

3-3. SOUND LEVEL

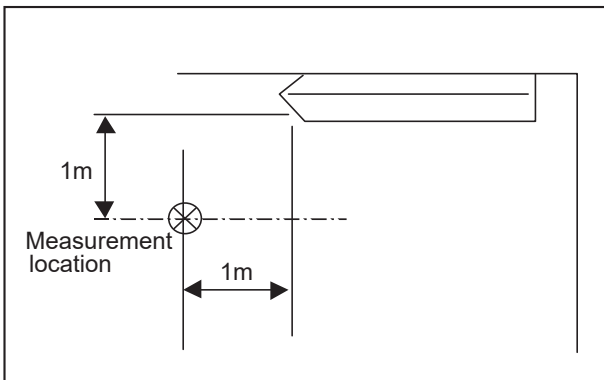

* Measured in anechoic room.

Sound level at anechoic room : Low-Mid2-Mid1-High

Service Ref.	Sound level dB (A)
PCFY-MS40VKM-E PCFY-MS40VKM-ET	29-32-34-36
PCFY-MS63VKM-E PCFY-MS63VKM-ET	31-33-35-37
PCFY-MS100VKM-E PCFY-MS100VKM-ET	36-38-41-43
PCFY-MS125VKM-E PCFY-MS125VKM-ET	36-39-42-44

3-4. NC CURVES

PCFY-MS40VKM-E PCFY-MS40VKM-ET

External static pressure : 0 Pa
Power source : 220, 230, 240 V, 50 Hz / 220 V, 60 Hz

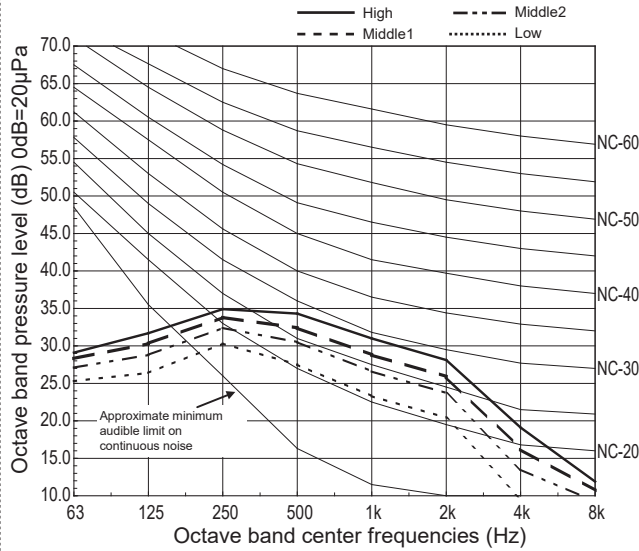

PCFY-MS63VKM-E PCFY-MS63VKM-ET

External static pressure : 0 Pa
Power source : 220, 230, 240 V, 50 Hz / 220 V, 60 Hz

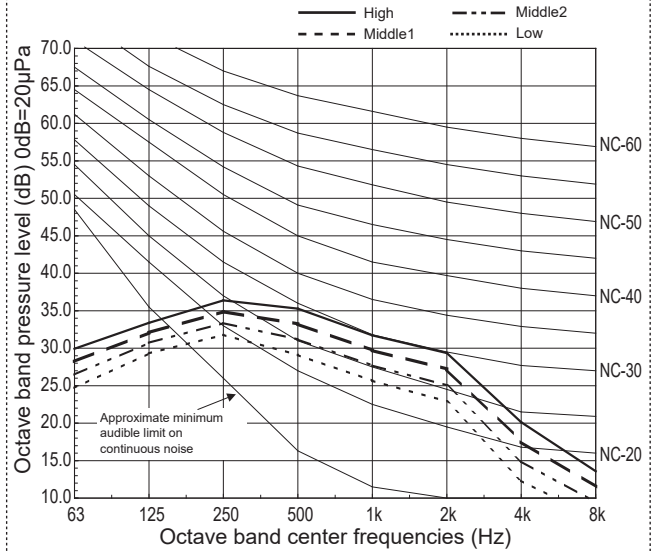

PCFY-MS100VKM-E PCFY-MS100VKM-ET

External static pressure : 0 Pa
Power source : 220, 230, 240 V, 50 Hz / 220 V, 60 Hz

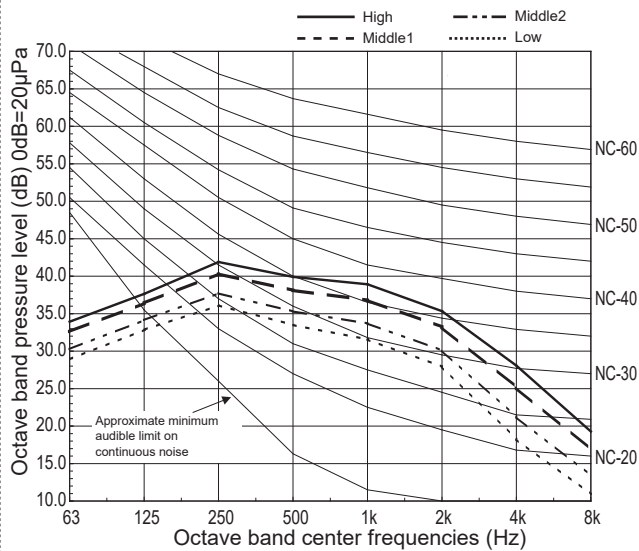

PCFY-MS125VKM-E PCFY-MS125VKM-ET

External static pressure : 0 Pa
Power source : 220, 230, 240 V, 50 Hz / 220 V, 60 Hz

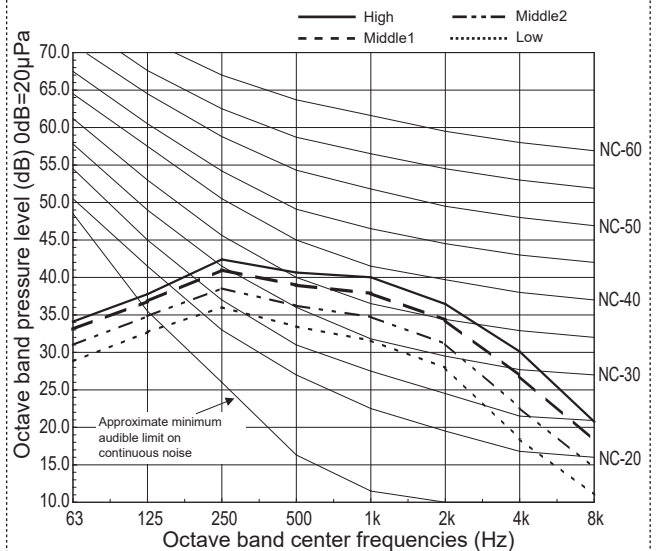



3-5. FRESH AIR INTAKE AMOUNT & STATIC PRESSURE CHARACTERISTICS

PCFY-MS40VKM-E
PCFY-MS40VKM-ET



PCFY-MS63VKM-E
PCFY-MS63VKM-ET

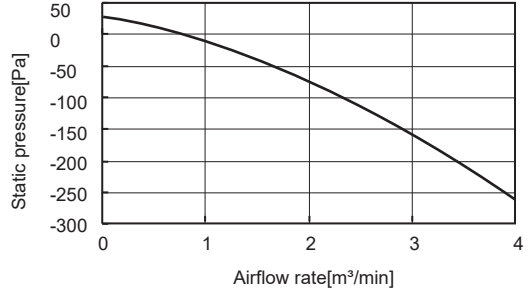

PCFY-MS100/125VKM-E
PCFY-MS100/125VKM-ET



How to read curves

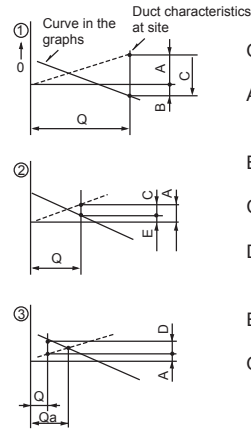

- Q...Designed amount of fresh air intake <m³/min>
- A...Static pressure loss of fresh air intake duct system with airflow amount Q <Pa>
- B...Forced static pressure at air conditioner inlet with airflow amount Q <Pa>
- C...Static pressure of booster fan with airflow amount Q <Pa>
- D...Static pressure loss increase amount of fresh air intake duct system for airflow amount Q <Pa>
- E...Static pressure of indoor unit with airflow amount Q <Pa>
- Qa...Estimated amount of fresh air intake without D <m³/min>

PCFY-MS40VKM-E
PCFY-MS40VKM-ET

Unit : mm

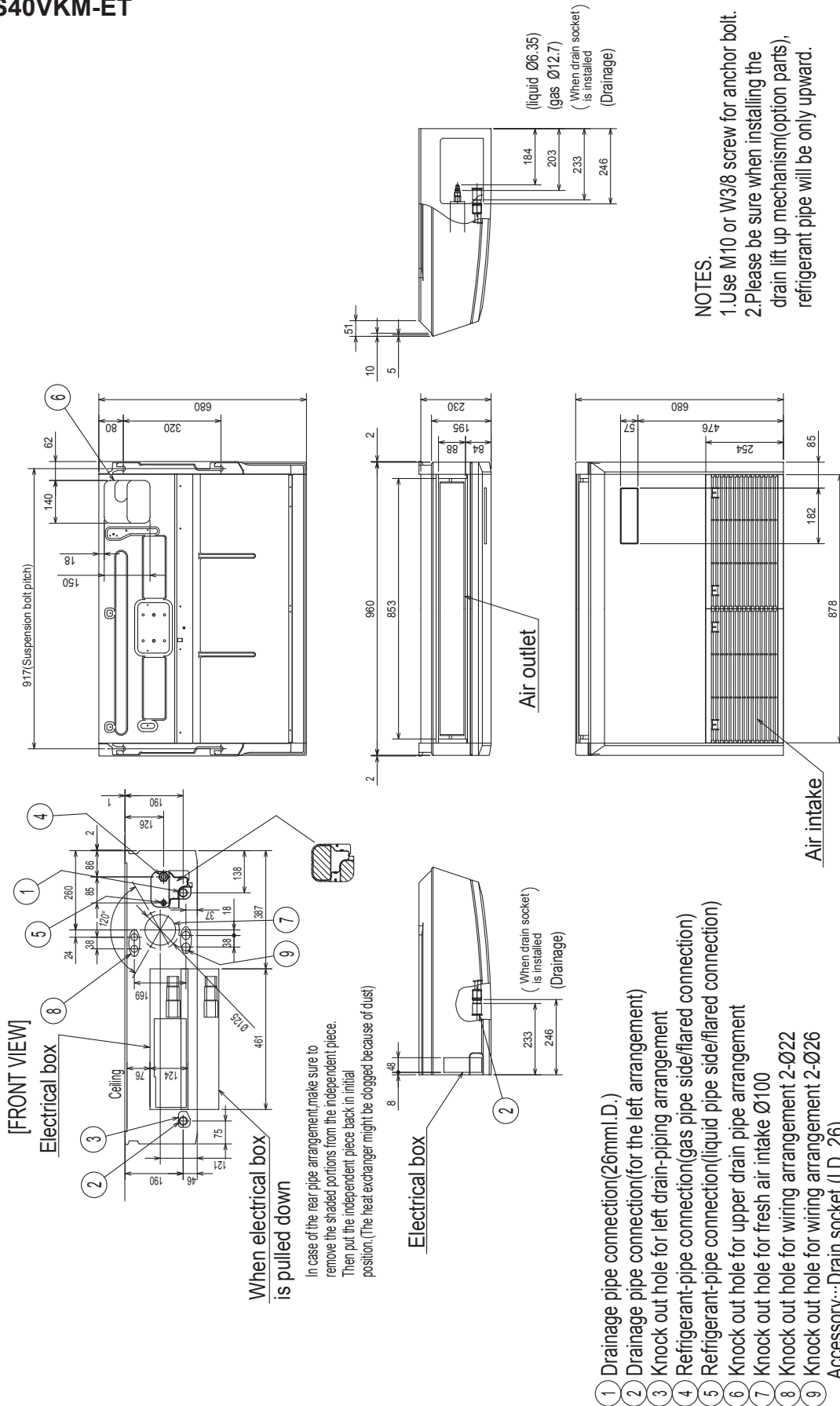

PCFY-MS63VKM-E
PCFY-MS63VKM-ET

Unit : mm

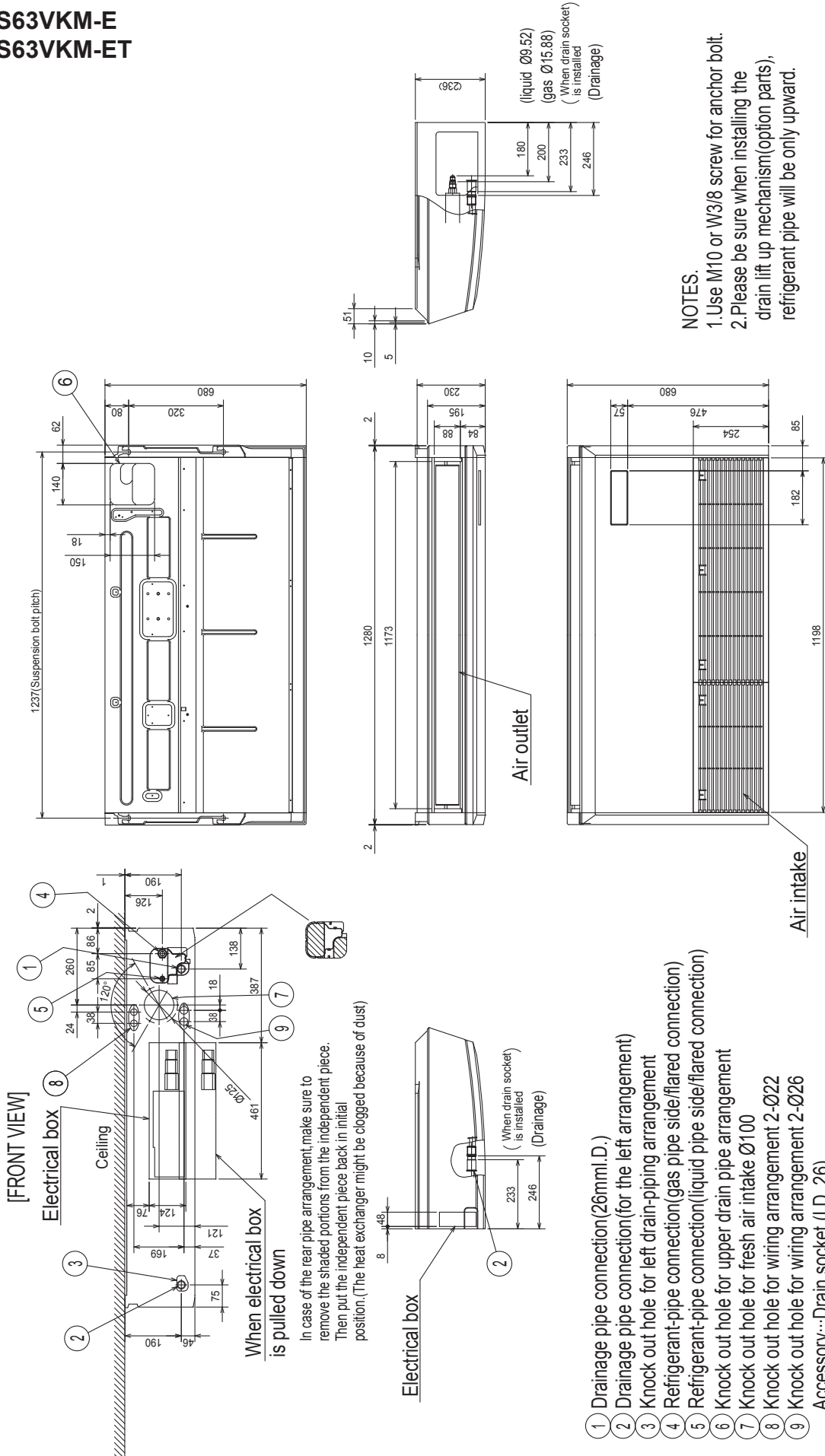

NOTES.
 1. Use M10 or W3/8 screw for anchor bolt.
 2. Please be sure when installing the drain lift up mechanism (option parts), refrigerant pipe will be only upward.

- ① Drainage pipe connection (26mm I.D.)
 - ② Drainage pipe connection (for the left arrangement)
 - ③ Knock out hole for left drain-piping arrangement
 - ④ Refrigerant-pipe connection (gas pipe side/flared connection)
 - ⑤ Refrigerant-pipe connection (liquid pipe side/flared connection)
 - ⑥ Knock out hole for upper drain pipe arrangement
 - ⑦ Knock out hole for fresh air intake Ø100
 - ⑧ Knock out hole for wiring arrangement 2-Ø22
 - ⑨ Knock out hole for wiring arrangement 2-Ø26
- Accessory...: Drain socket (I.D. 26)

[LEGEND]

SYMBOL	NAME	SYMBOL	NAME
I. B	INDOOR CONTROLLER BOARD	TB2	TERMINAL BLOCK
CN32	CONNECTOR	TB5	TERMINAL BLOCK
CN51	CONNECTOR	TH21	THERMISTOR
CN52	CONNECTOR	TH22	THERMISTOR
CN105	CONNECTOR	TH23	THERMISTOR
F1	FUSE (T6.3AL250V)	OPTIONAL PARTS	
SW1	SWITCH	W.B	PCB FOR WIRELESS REMOTE CONTROLLER
SW2	SWITCH	BZ	BUZZER
SW3	SWITCH	LED1	LED (OPERATION INDICATION : GREEN)
SW11	SWITCH	LED2	LED (PREPARATION FOR HEATING : ORANGE)
SW12	SWITCH	RU	RECEIVING UNIT
SW14	SWITCH	SW1	EMERGENCY OPERATION (HEAT / DOWN)
SW21	SWITCH	SW2	EMERGENCY OPERATION (COOL / UP)
SW22	SWITCH	D.P	DRAIN PUMP KIT
SWE	SWITCH	DP	DRAIN PUMP
X1	AUX. RELAY	FS	DRAIN FLOAT SWITCH
LEV	LINEAR EXPANSION VALVE		
DCL	REACTOR		
MF	FAN MOTOR		
MV	VANE MOTOR		

<Table 1>

MODELS	SW2	SW3
40	ON OFF 1 2 3 4 5 6	ON OFF 1 2 3 4 5 6 7 8 9 0
63	ON OFF 1 2 3 4 5 6	ON OFF 1 2 3 4 5 6 7 8 9 0
100	ON OFF 1 2 3 4 5 6	ON OFF 1 2 3 4 5 6 7 8 9 0
125	ON OFF 1 2 3 4 5 6	ON OFF 1 2 3 4 5 6 7 8 9 0

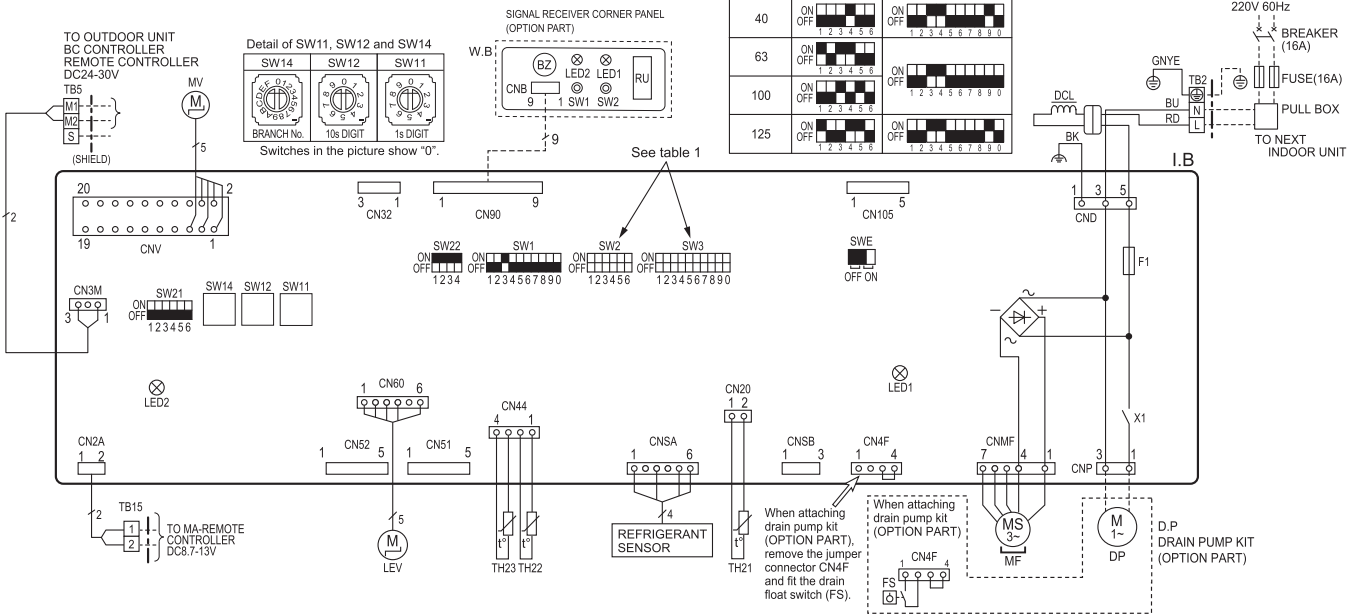

LED on indoor board for service

Mark	Meaning	Function
LED1	Main power supply	Main Power supply (Indoor unit:220-240V AC) power on → lamp is lit
LED2	Power supply for MA-Remote controller	Power supply for MA-Remote controller on → lamp is lit

NOTES:

- At servicing for outdoor unit, always follow the wiring diagram of outdoor unit.
- In case of using MA-Remote controller, please connect to TB15.
(Remote controller wire is non-polar.)
- In case of using M-NET, please connect to TB5. (Transmission line is non-polar.)
- Symbol [S] of TB5 is the shield wire connection.
- Symbols used in wiring diagram are, □□□□ : terminal block, ○○○○, □□□□ : connector.
- The setting of the SW2, SW3 differs in the capacity. For the detail, see table 1.
- The black square (■) in the wiring diagram indicates a switch position.

6

REFRIGERANT SYSTEM DIAGRAM

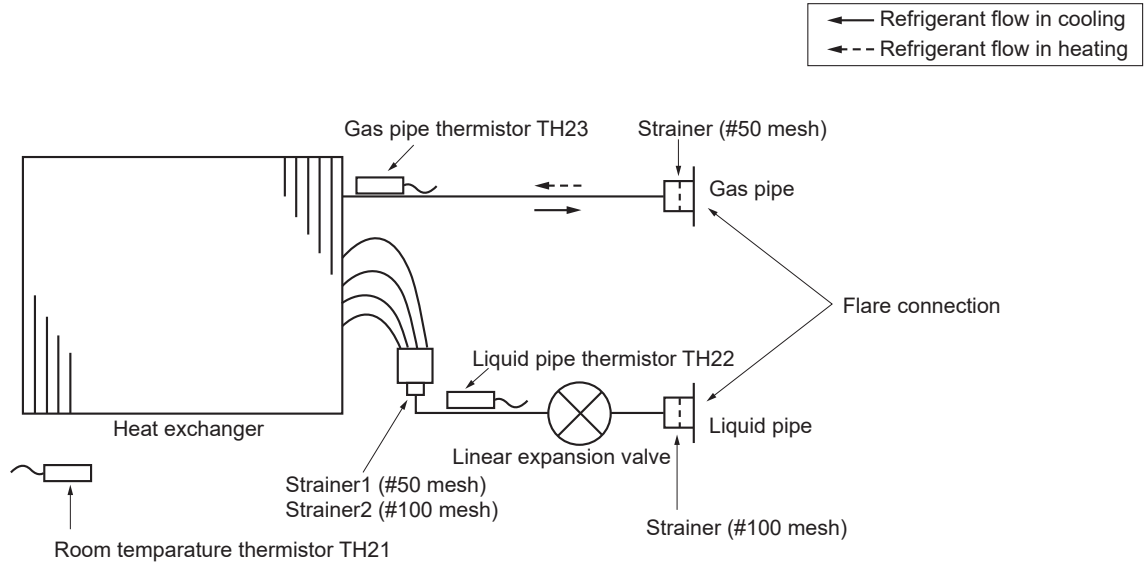

Unit : mm (in)

Service Ref.	PCFY-MS40VKM-E PCFY-MS40VKM-ET	PCFY-MS63VKM-E PCFY-MS63VKM-ET PCFY-MS100VKM-E PCFY-MS100VKM-ET PCFY-MS125VKM-E PCFY-MS125VKM-ET
Item		
Gas pipe	ø12.7 (1/2)	ø15.88 (5/8)
Liquid pipe	ø6.35 (1/4)	ø9.52 (3/8)

7-1. COUNTERMEASURES FOR ERROR DURING TEST RUN

If a problem occurs during test run, a code number will appear on the remote controller (or LED on the outdoor unit), and the air conditioning system will automatically cease operating.

Refer to the connected outdoor unit service manual in order to determine the nature of the abnormality and apply corrective measure.

Check code	Trouble	Detected Unit			Remarks
		Indoor	Outdoor	Remote Controller	
0403	Serial communication error		○		Outdoor unit Multi controller board ~ Power board communication trouble
1102	Compressor temperature		○		Check delay code 1202
1300	Low pressure		○		
1302	High pressure		○		Check delay code 1402
1500	Superheat due to low discharge temperature		○		Check delay code 1600
1501	Refrigerant shortage		○		Check delay code 1601
	Closed valve in cooling mode		○		Check delay code 1501
1503	Freeze protection of branch box or indoor unit		○		
1508	4-way valve trouble in heating mode		○		Check delay code 1608
1521	Refrigerant leakage	○			
1522					
2500	Water leakage	○			
2502	Drain overflow protection	○			
2503	Drain sensor abnormality	○			
4100	Compressor current interruption (locked compressor)		○		Check delay code 4350
4114	Fan motor error	○			
4210	Compressor overcurrent interruption		○		
4220	Undervoltage/overvoltage/PAM error/L1open phase/power synchronization signal error		○		Check delay code 4320
4230	Heat Sink temperature		○		Check delay code 4330
4250	Power module		○		Check delay code 4350
4400	Fan trouble		○		Check delay code 4500
5101	Air inlet thermistor (TH21) open/short	○			
	Compressor temperature thermistor (TH4) open/short		○		Check delay code 1202
5102	Liquid pipe temperature thermistor (TH22) open/short	○			
	Suction pipe temperature thermistor (TH6) open/short		○		Check delay code 1211
5103	Gas pipe temperature thermistor (TH23) open/short	○			
5105	Outdoor liquid pipe temperature thermistor (TH3) open/short		○		Check delay code 1205
5106	Ambient thermistor (TH7) open/short		○		Check delay code 1221
5109	HIC pipe temperature thermistor (TH2) open/short		○		Check delay code 1222
5110	Heat Sink temperature thermistor (TH8) open/short		○		Check delay code 1214
5201	High pressure sensor (63HS)		○		Check delay code 1402
5202	Low pressure sensor (63LS)		○		Check delay code 1400
5558	Refrigerant sensor error	○			
5701	Contact failure of drain float switch	○			
6600	Duplex address error	○	○	○	Only M-NET Remote controller is detected.
6602	Transmission processor hardware error	○	○	○	Only M-NET Remote controller is detected.
6603	Transmission bus BUSY error	○	○	○	Only M-NET Remote controller is detected.
6606	Signal communication error with transmission processor	○	○	○	Only M-NET Remote controller is detected.
6607	No ACK error	○		○	Only M-NET Remote controller is detected. *
6608	No response frame error	○		○	Only M-NET Remote controller is detected. *
6815	MA supervisor remote controller communication error	○			
6831	MA communication receive error (no receive signal)	○		○	Only MA Remote controller is detected.
6832	MA communication send error	○		○	Only MA Remote controller is detected.
6833	MA communication send error	○		○	Only MA Remote controller is detected.
6834	MA communication receive error	○		○	Only MA Remote controller is detected.
7100	Total capacity error		○		
7101	Capacity code error	○	○		
7102	Connecting excessive number of units		○		
7105	Address setting error		○		
7118	Refrigerant leak detection system error		○		
7130	Incompatible unit combination		○		

Note:

When the outdoor unit detects No ACK error/No response error, an object indoor unit is treated as a stop, and not assumed to be abnormal.

*Abnormality for PWFY series

7-2. HOW TO CHECK THE PARTS

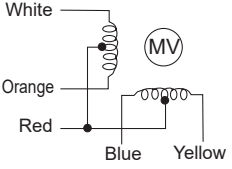
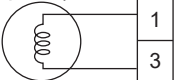
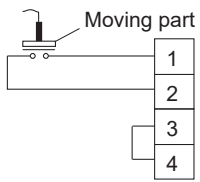
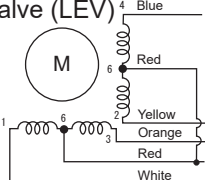
Parts name	Checkpoints														
Room temperature thermistor (TH21) Liquid pipe thermistor (TH22) Gas pipe thermistor (TH23)	Disconnect the connector then measure the resistance with a tester. (At the ambient temperature of 10°C~30°C) <table border="1" style="margin-left: 20px;"> <thead> <tr> <th>Normal</th> <th>Abnormal</th> </tr> </thead> <tbody> <tr> <td>4.3 kΩ~9.6 kΩ</td> <td>Open or short</td> </tr> </tbody> </table> (Refer to Thermistor characteristic graph.)	Normal	Abnormal	4.3 kΩ~9.6 kΩ	Open or short										
Normal	Abnormal														
4.3 kΩ~9.6 kΩ	Open or short														
Vane motor (MV) 	Measure the resistance between the terminals with a tester. (At the ambient temperature of 20°C~30°C) <table border="1" style="margin-left: 20px;"> <thead> <tr> <th>Connector</th> <th>Normal</th> <th>Abnormal</th> </tr> </thead> <tbody> <tr> <td>Red - Yellow</td> <td rowspan="4" style="text-align: center; vertical-align: middle;">$300 \Omega \pm 7\%$</td> <td rowspan="4" style="text-align: center; vertical-align: middle;">Open or short</td> </tr> <tr> <td>Red - Blue</td> </tr> <tr> <td>Red - Orange</td> </tr> <tr> <td>Red - White</td> </tr> </tbody> </table>	Connector	Normal	Abnormal	Red - Yellow	$300 \Omega \pm 7\%$	Open or short	Red - Blue	Red - Orange	Red - White					
Connector	Normal	Abnormal													
Red - Yellow	$300 \Omega \pm 7\%$	Open or short													
Red - Blue															
Red - Orange															
Red - White															
Drain pump (DP) (Option) 	Measure the resistance between the terminals with a tester. (Winding temperature 20°C) <table border="1" style="margin-left: 20px;"> <thead> <tr> <th>Normal</th> <th>Abnormal</th> </tr> </thead> <tbody> <tr> <td>$333 \Omega \pm 10\%$</td> <td>Open or short</td> </tr> </tbody> </table>	Normal	Abnormal	$333 \Omega \pm 10\%$	Open or short										
Normal	Abnormal														
$333 \Omega \pm 10\%$	Open or short														
Drain float switch (FS) (Option) 	Measure the resistance between the terminals with a tester. <table border="1" style="margin-left: 20px;"> <thead> <tr> <th>State of moving part</th> <th>Normal</th> <th>Abnormal</th> </tr> </thead> <tbody> <tr> <td>UP</td> <td>Short</td> <td>Other than short</td> </tr> <tr> <td>DOWN</td> <td>Open</td> <td>Other than open</td> </tr> </tbody> </table>	State of moving part	Normal	Abnormal	UP	Short	Other than short	DOWN	Open	Other than open					
State of moving part	Normal	Abnormal													
UP	Short	Other than short													
DOWN	Open	Other than open													
Linear expansion valve (LEV) 	Disconnect the connector then measure the resistance value with a tester. <table border="1" style="margin-left: 20px;"> <thead> <tr> <th colspan="4">Normal</th> <th>Abnormal</th> </tr> </thead> <tbody> <tr> <td>White-Red</td> <td>Yellow-Red</td> <td>Orange-Red</td> <td>Blue-Red</td> <td rowspan="2" style="text-align: center; vertical-align: middle;">Open or short</td> </tr> <tr> <td colspan="4" style="text-align: center;">$200 \Omega \pm 10\%$</td> </tr> </tbody> </table> Refer to 7-2-2 for details.	Normal				Abnormal	White-Red	Yellow-Red	Orange-Red	Blue-Red	Open or short	$200 \Omega \pm 10\%$			
Normal				Abnormal											
White-Red	Yellow-Red	Orange-Red	Blue-Red	Open or short											
$200 \Omega \pm 10\%$															

7-2-1. Thermistor

<Thermistor characteristic graph>

Thermistors for lower temperature

Room temperature thermistor (TH21)
Liquid pipe temperature thermistor (TH22)
Gas pipe temperature thermistor (TH23)

Thermistor $R_0=15 \text{ k}\Omega \pm 3\%$
Fixed number of $B=3480 \pm 2\%$

$$R_t = 15 \exp \left\{ 3480 \left(\frac{1}{273+t} - \frac{1}{273} \right) \right\}$$

0°C	15 kΩ
10°C	9.6 kΩ
20°C	6.3 kΩ
25°C	5.4 kΩ
30°C	4.3 kΩ
40°C	3.0 kΩ

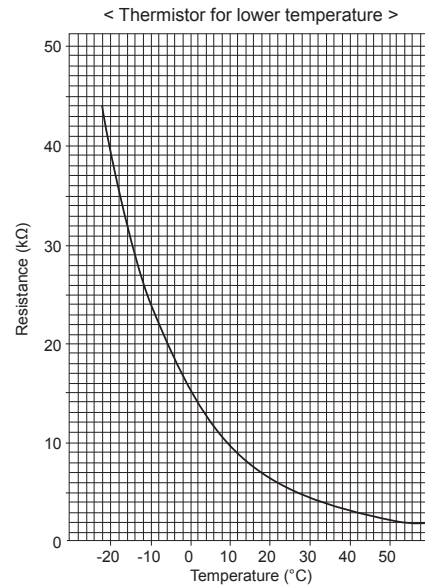

7-2-2. Linear expansion valve

① Operation summary of the linear expansion valve

- Linear expansion valves open/close through the use of a stepping motor after receiving the pulse signal from the indoor controller board.
- Valve position can be changed in proportion to the number of pulse signals.

<Connection between the indoor controller board and the linear expansion valve>

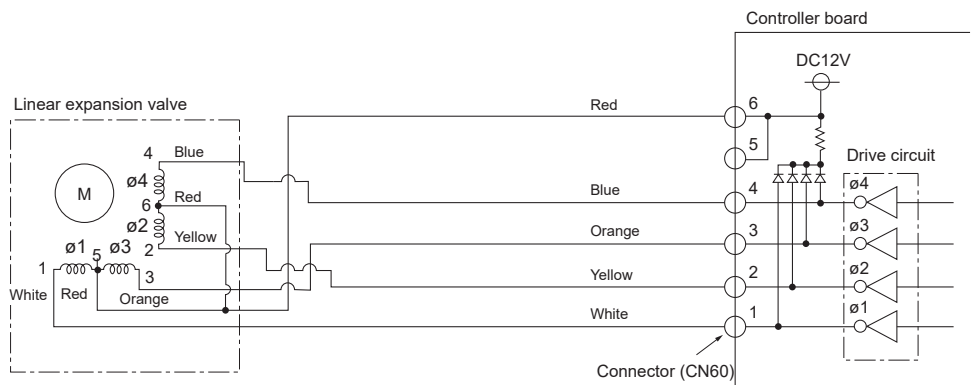

Note : Since the number of the connector at the controller board side and the relay connector are different, follow the color of the lead wire.

<Output pulse signal and the valve operation>

Output (Phase)	Output			
	1	2	3	4
ø1	ON	OFF	OFF	ON
ø2	ON	ON	OFF	OFF
ø3	OFF	ON	ON	OFF
ø4	OFF	OFF	ON	ON

The output pulse shifts in the following order.

Closing a valve : 1 → 2 → 3 → 4 → 1

Opening a valve : 4 → 3 → 2 → 1 → 4

Note:

- When linear expansion valve operation stops, all output phase become OFF.
- At phase interruption or when phase does not shift in order, motor does not rotate smoothly and motor will lock and vibrate.

② Linear expansion valve operation

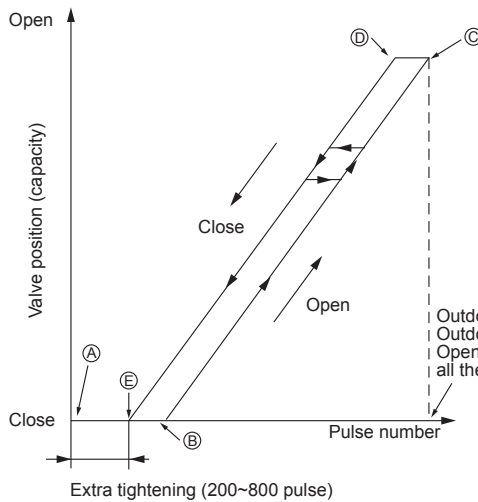

- When the switch is turned on, 2200 pulse closing valve signal will be sent till it goes to point A in order to define the valve position.

When the valve moves smoothly, there is no sound or vibration occurring from the linear expansion valves, however, when the pulse number moves from C to A or when the valve is locked, more sound can be heard than in a normal situation.

- Sound can be detected by placing the ear against the screw driver handle while putting the screw driver tip to the linear expansion valve.

③ Troubleshooting

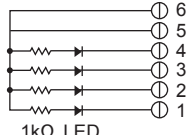
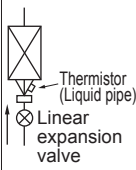
Symptom	Check points	Countermeasures
Operation circuit failure of the micro processor	Disconnect the connector on the controller board, then connect LED for checking.  1kΩ LED When power is turned on, pulse signals will output for 10 seconds. There must be some defects in the operation circuit if the LED does not light while the signals are output or keeps lighting even after the signals stop.	Exchange the indoor controller board at drive circuit failure.
Linear expansion valve mechanism is locked.	Motor will idle and make a ticking noise when the motor is operated while the linear expansion valve is locked. This ticking sound is the sign of the abnormality.	Exchange the linear expansion valve.
Short or breakage of the motor coil of the linear expansion valve	Measure the resistance between each coil (white-red, yellow-brown, orange-red, blue-brown) using a tester. It is normal if the resistance is in the range of 200Ω ±10%.	Exchange the linear expansion valve.
Valve does not close completely.	To check the linear expansion valve, operate the indoor unit in fan mode and at the same time operate other indoor units in cooling mode, then check the pipe temperature <liquid pipe temperature> of the indoor unit by the outdoor multi controller board operation monitor. During fan operation, linear expansion valve is closed completely and if there is any leaking, detecting temperature of the thermistor will go lower. If the detected temperature is much lower than the temperature indicated in the remote controller, it means the valve is not closed all the way.  Thermistor (Liquid pipe) Linear expansion valve It is not necessary to exchange the linear expansion valve, if the leakage is small and not affecting normal operation.	If large amount of refrigerant is leaked, exchange the linear expansion valve.
Wrong connection of the connector or contact failure	Check the color of lead wire and missing terminal of the connector.	Disconnect the connector at the controller board, then check the continuity.

7-2-3. DC Fan motor (fan motor/indoor controller circuit board)

Check method of DC fan motor (fan motor/indoor controller circuit board)

① Notes

- High voltage is applied to the connector (CNMF) for the fan motor. Pay attention to the service.
- Do not pull out the connector (CNMF) for the motor with the power supply on.
(It causes trouble of the indoor controller board and fan motor.)





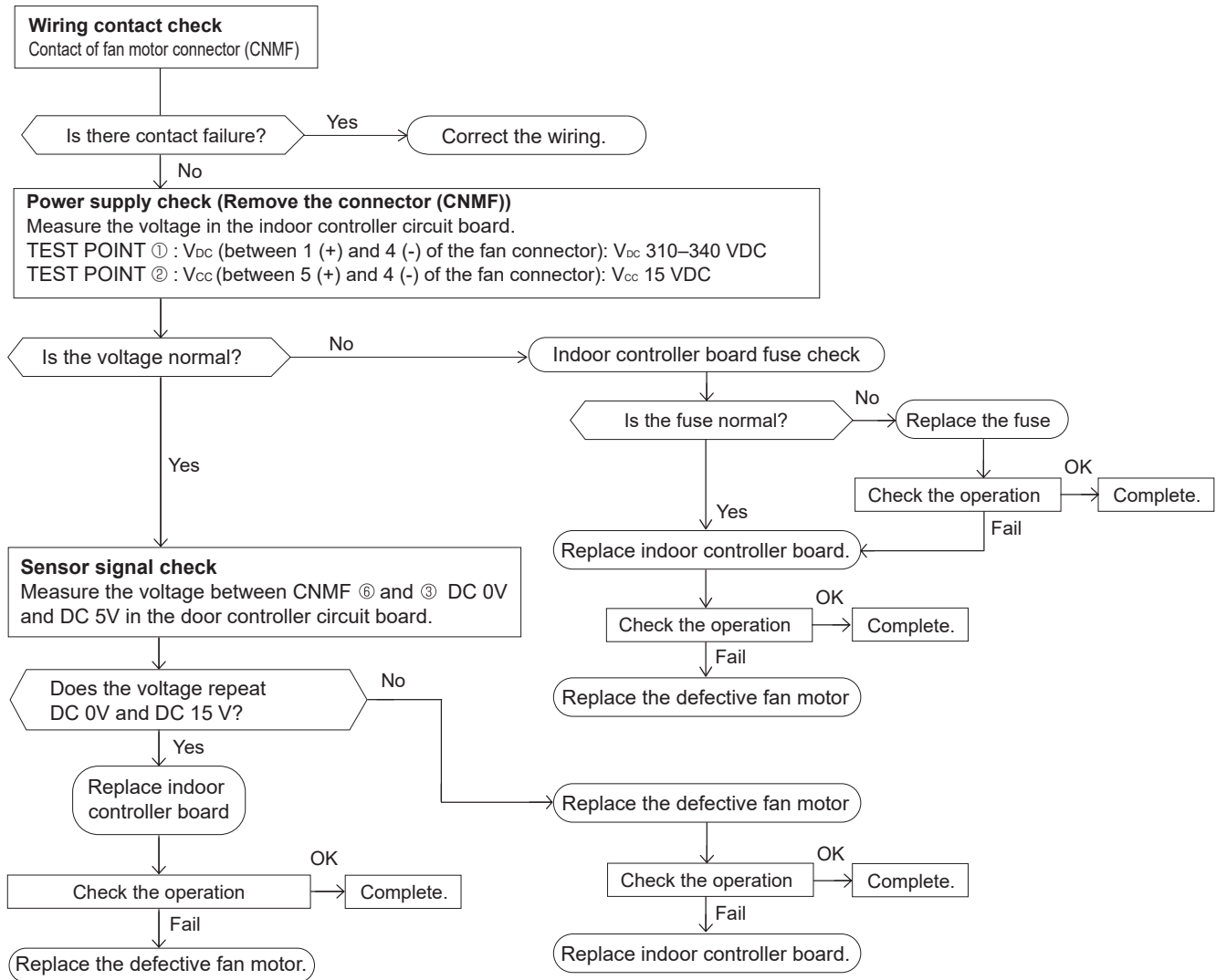









② Self check

Symptom : The indoor fan cannot turn around.





7-3. FUNCTION OF DIP SWITCH

The black square (■) indicates a switch position.

Switch	Pole	Function	Operation by switch		Effective timing	Remarks															
			ON	OFF																	
SW1 Function setting	1	Thermistor <Room temperature detection> position	Built-in remote controller	Indoor unit	Under suspension	<p><Initial setting></p> <p>ON </p> <p>OFF</p> <p>Note :</p> <p>*1 Fan operation at heating mode</p> <p>*2 Thermo ON operation at heating mode</p> <p>*3</p> <table border="1" data-bbox="1236 638 1492 772"> <tr> <td>SW1-7</td> <td>SW1-8</td> <td></td> </tr> <tr> <td>OFF</td> <td>OFF</td> <td>Extra low</td> </tr> <tr> <td>ON</td> <td>OFF</td> <td>Low</td> </tr> <tr> <td>OFF</td> <td>ON</td> <td>Setting airflow</td> </tr> <tr> <td>ON</td> <td>ON</td> <td>Stop</td> </tr> </table>	SW1-7	SW1-8		OFF	OFF	Extra low	ON	OFF	Low	OFF	ON	Setting airflow	ON	ON	Stop
	SW1-7	SW1-8																			
	OFF	OFF	Extra low																		
	ON	OFF	Low																		
	OFF	ON	Setting airflow																		
	ON	ON	Stop																		
	2	Filter clogging detection	Provided	Not provided																	
	3	Filter cleaning	2,500 hr	100 hr																	
	4	Fresh air intake	Effective	Not effective																	
	5	Switching remote display	Thermo ON signal display	Indicating fan operation ON/OFF																	
6	Humidifier control	Always operated while the heat in ON *1	Operated depends on the condition *2																		
7	Airflow set in case of Heat thermo OFF at heating mode	Low *3	Extra low *3																		
8		Setting air flow *3	Depends on SW1-7																		
9	Auto restart function	Effective	Not effective																		
10	Power ON/OFF by breaker	Effective	Not effective																		
SW2 Capacity code setting	1~6	<table border="1" data-bbox="311 907 837 1131"> <thead> <tr> <th>Capacity</th> <th>SW 2</th> <th>Capacity</th> <th>SW 2</th> </tr> </thead> <tbody> <tr> <td>40</td> <td>ON </td> <td>63</td> <td>ON </td> </tr> <tr> <td>100</td> <td>ON </td> <td>125</td> <td>ON </td> </tr> </tbody> </table>	Capacity	SW 2	Capacity	SW 2	40	ON 	63	ON 	100	ON 	125	ON 		Before power supply ON	<p><Initial setting></p> <p>Set for each capacity.</p>				
		Capacity	SW 2	Capacity	SW 2																
		40	ON 	63	ON 																
		100	ON 	125	ON 																
SW3 Function setting	1	Heat pump/Cooling only	Cooling only	Heat pump	Under suspension	<p><Initial setting></p> <p>ON </p> <p>OFF</p> <p>Note :</p> <p>*4 SW3-5</p> <p>*5 Each angle can be used only 1 hour when fan speed setting Low and Middle 1,2</p> <p>*6 Please do not use SW3-9, 10. SW9 setting MS40, MS125: ON MS63, MS100: OFF</p>															
	2	Louver	Available	Not available																	
	3	Vane	Available	Not available																	
	4	Vane swing function	Available	Not available																	
	5	Vane horizontal angle	Second setting *4	First setting *4																	
	6	Vane cooling limit angle setting *5	Horizontal	Setting A,B,C,D																	
	7	Changing the opening of linear expansion valve	Effective	Not effective																	
	8	4-deg up (Heating mode)	Not effective	Effective																	
	9	Superheat setting temperature *6	—	—																	
	10	Sub cool setting temperature *6	—	—																	

Note : *4 SW3-5

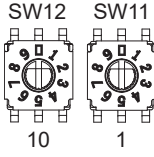
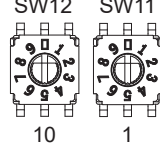
SW3-5	Vane setting	Initial setting	Setting	Vane position
OFF	Set up ①	●	Standard	Standard
ON	Set up ②		Less draft	Upward position than the standard

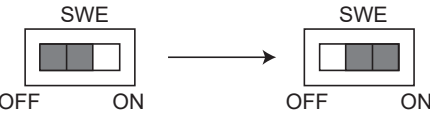
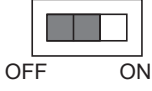
Switch	Pole	Function	Operation by switch		Effective timing	Remarks
			ON	OFF		
SW11 1s digit address setting SW12 10s digit address setting	Rotary switch	<p>How to set address Example : If address is "3", remain SW12 (for over 10) at "0", and match SW11 (for 1 to 9) with "3".</p> 			Before power supply ON	<p><Initial setting></p> 
SW14 Branch No. setting	Rotary switch	 <p>How to set branch number SW14 (Series R2 only) Match the indoor unit's refrigerant pipe with the BC controller's end connection number Remain other than series R2 at "0".</p>				<p><Initial setting></p> 
SWE Test run for drain pump (Option)	Connector	<p>Drain pump and fan are activated simultaneously after the connector SWE is set to ON and turn on the power.</p>  <p>The connector SWE is set to OFF after test run.</p>			Under operation	<p><Initial setting></p> 

* Set the switch while the indoor unit and the outdoor unit are both OFF.

The black square (■) indicates a switch position.

Switch	Pole	Function	Operation by switch		Effective timing	Remarks																					
			ON	OFF																							
SW21 Function Selection	1	Setting the ceiling height	Depending on the combination of SW21-1 and SW21-2.		Under Suspension	<Initial setting> ON ■■■■■■ OFF ■■■■■■ 1 2 3 4 5 6																					
	2	Setting the ceiling height																									
	3	Not used	Not used	Not used																							
	4	Not used	Not used	Not used																							
	5	Setting for optional parts	Option	Standard																							
	6	Not used	Not used	Not used																							
SW22 Function Selection	Switch	<table border="1"> <thead> <tr> <th>Function</th> <th>ON</th> <th>OFF</th> </tr> </thead> <tbody> <tr> <td>1</td> <td>—</td> <td>—</td> </tr> <tr> <td>2</td> <td>—</td> <td>—</td> </tr> <tr> <td>3 Pair No. of wireless remote controller</td> <td colspan="2" rowspan="2">Depends on the combination of SW22-3 and 22-4</td> </tr> <tr> <td>4 Pair No. of wireless remote controller</td> </tr> </tbody> </table>		Function	ON	OFF	1	—	—	2	—	—	3 Pair No. of wireless remote controller	Depends on the combination of SW22-3 and 22-4		4 Pair No. of wireless remote controller	<ul style="list-style-type: none"> To operate each indoor unit by each remote controller when installed 2 indoor units or more are near, Pair No. setting is necessary. Pair No. setting is available with the 4 patterns. Make setting for SW22-3, 22-4 of indoor controller board and the Pair No. of wireless remote controller. <ul style="list-style-type: none"> Pair No. setting is not set necessarily when operating it by one remote controller. <p>① Setting for indoor unit</p> <ul style="list-style-type: none"> Set SW22-3, 22-4 on the indoor controller board according to the table below. <p>② Wireless remote controller pair number:</p> <ul style="list-style-type: none"> Setting operation (Fig. 1 A) <ol style="list-style-type: none"> Press the button ① to stop the air conditioner. Press the button ②. Check that function No."1" is displayed, and then press the button ③. The Screen display setting screen will be displayed. (Fig. 2.) <ul style="list-style-type: none"> Pair No. changing operation (Fig. 2 B) <ol style="list-style-type: none"> Press the button ④. Each time the button ④ is pressed, the pair No.0-3 changes. Press the button ③ to check the setting. Press the button ②. 		<Initial setting> ON ■■■■ OFF ■■■■ 1 2 3 4								
Function	ON	OFF																									
1	—	—																									
2	—	—																									
3 Pair No. of wireless remote controller	Depends on the combination of SW22-3 and 22-4																										
4 Pair No. of wireless remote controller																											
		<table border="1"> <thead> <tr> <th colspan="2">Indoor unit SW22</th> <th rowspan="2">Pair No. of wireless remote controller</th> <th rowspan="2"></th> </tr> <tr> <th>SW22-3</th> <th>SW22-4</th> </tr> </thead> <tbody> <tr> <td>ON</td> <td>ON</td> <td>0</td> <td>Initial setting</td> </tr> <tr> <td>OFF</td> <td>ON</td> <td>1</td> <td>—</td> </tr> <tr> <td>ON</td> <td>OFF</td> <td>2</td> <td>—</td> </tr> <tr> <td>OFF</td> <td>OFF</td> <td>3-9</td> <td>—</td> </tr> </tbody> </table>		Indoor unit SW22		Pair No. of wireless remote controller		SW22-3	SW22-4	ON	ON	0	Initial setting	OFF	ON	1	—	ON	OFF	2	—	OFF	OFF	3-9	—	Under operation or suspension	
Indoor unit SW22		Pair No. of wireless remote controller																									
SW22-3	SW22-4																										
ON	ON	0	Initial setting																								
OFF	ON	1	—																								
ON	OFF	2	—																								
OFF	OFF	3-9	—																								

Note: SW21-1,SW21-2

	Silent		Standard		High ceiling	
	SW21-1	SW21-2	SW21-1	SW21-2	SW21-1	SW21-2
	OFF	ON	OFF	OFF	ON	OFF
MS40,MS63	2.5m		2.7m		3.5m	
MS100,MS125	2.6m		3.0m		4.2m	

7-4. TEST POINT DIAGRAM

Indoor controller board

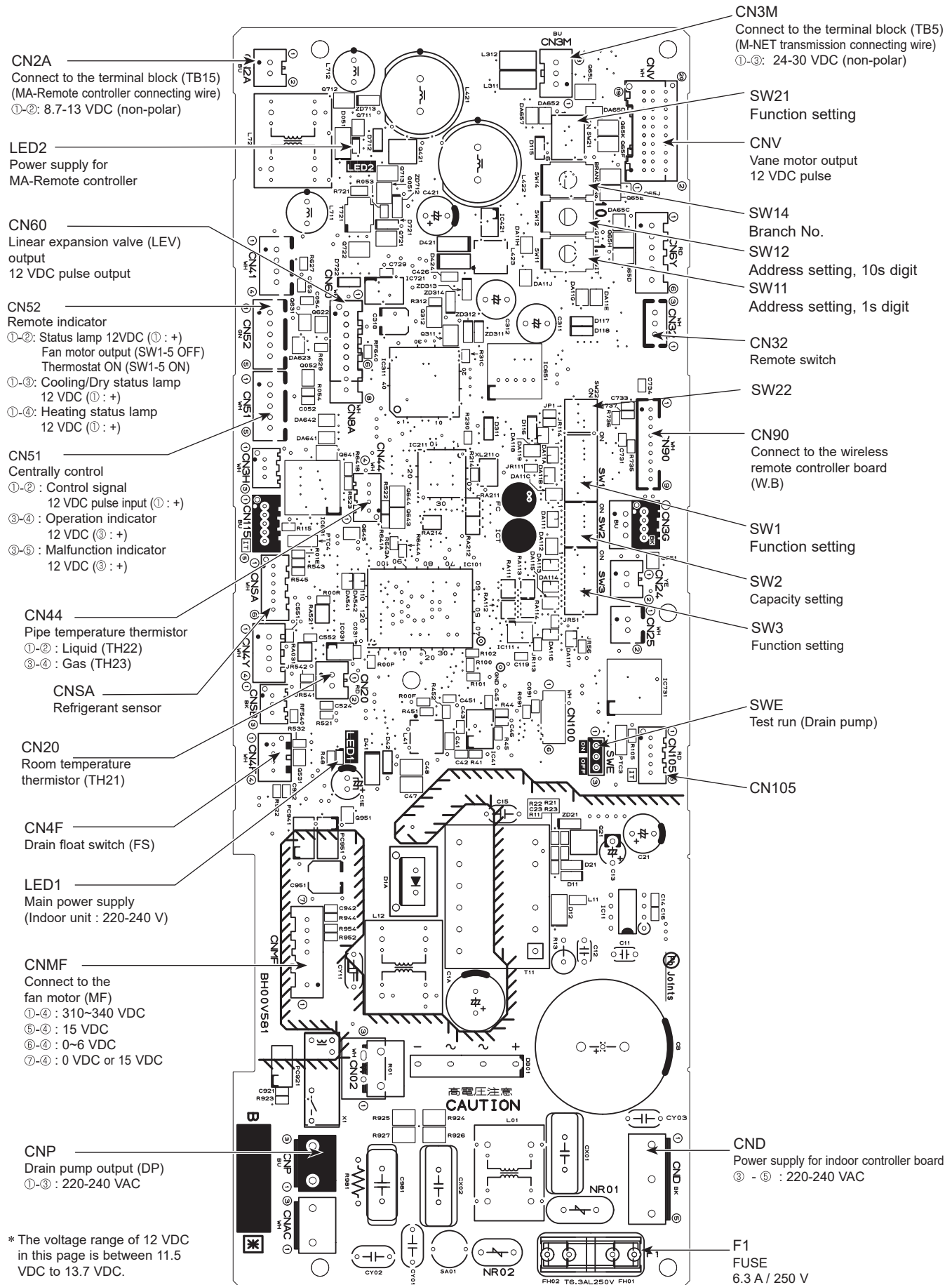

Be careful when removing heavy parts.

(Photo: PCFY-MS125VKM-E)

→ : Indicates the visible parts in the photos/figures.

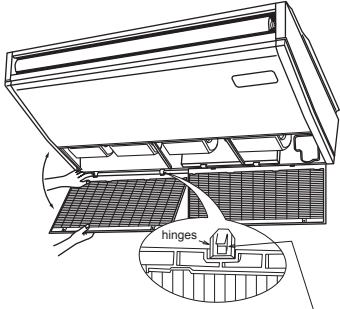
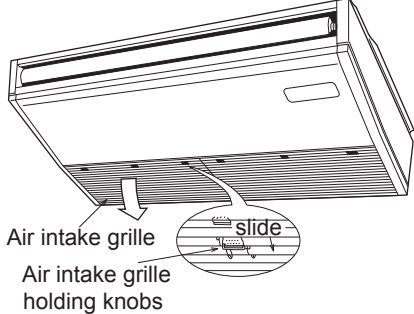
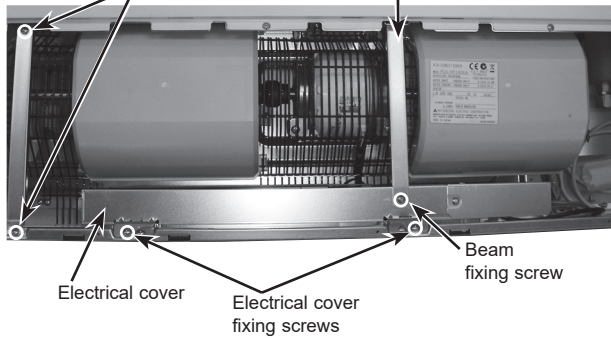
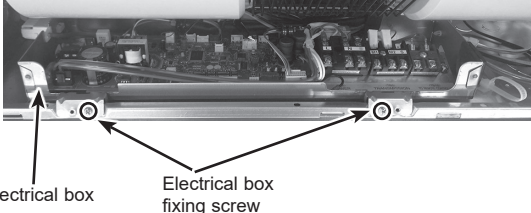
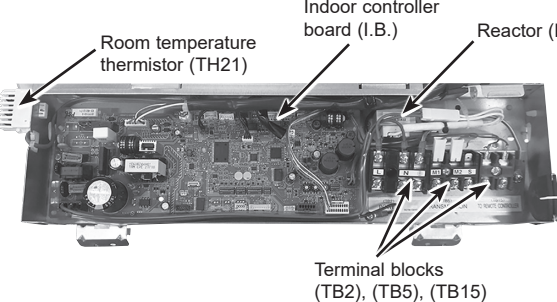
OPERATING PROCEDURE	PHOTOS/FIGURES
<p>1. Removing the air intake grille</p> <p>(1) Slide the air intake grille holding knobs (at 2 or 3 locations) to the rear to open the air intake grille. (See Figure 1)</p> <p>(2) While the air intake grille left open, push the stoppers on the rear hinges (at 2 or 3 locations) to pull out the air intake grille. (See Figure 2)</p> <p>Figure 2</p>  <p>Pull out the air intake grille</p>	<p>Figure 1</p>  <p>Air intake grille Air intake grille holding knobs</p>
<p>2. Removing the indoor controller board and the electrical box</p> <p>(1) Remove the air intake grille. (See Figure 1,2)</p> <p>(2) Remove the screw from the beam and remove the beam. (See Photo 1)</p> <p>(3) Remove 2 screws from the electrical cover, and remove the electrical cover.</p> <p>(4) Remove 2 screws from the electrical box and pull the electrical box downward. Temporarily secure the electrical box using 2 hooks in the back of electrical box.</p> <p>(5) Disconnect the connectors on the indoor controller board.</p> <p>[Removing the electrical box]</p> <p>(6) Disconnect the wires from the terminal blocks and pull out the electrical box. (See Photo 2)</p> <p>[Removing the indoor controller board]</p> <p>(6) Remove the 6 supports from the indoor controller board and remove the indoor controller board. (See Photo 3)</p>	<p>Photo 1</p>  <p>Beam fixing screws Beam Electrical cover Electrical cover fixing screws Beam fixing screw</p> <p>Photo 2</p>  <p>Electrical box Electrical box fixing screw</p> <p>Photo 3</p>  <p>Room temperature thermistor (TH21) Indoor controller board (I.B.) Reactor (DCL) Terminal blocks (TB2), (TB5), (TB15)</p>

OPERATING PROCEDURE

3. Removing the room temperature thermistor (TH21)

- (1) Remove the air intake grille. (See Figure 1, 2)
- (2) Remove the screw from the beam and remove the beam. (See Photo 1)
- (3) Remove 2 screws from the electrical cover, and remove the electrical cover.
- (4) Remove 2 screws from the electrical box and pull the electrical box downward. Temporarily secure the electrical box using 2 hooks in the back of electrical box.
- (5) Disconnect the connector CN20 (red) from the indoor controller board.
- (6) Remove the sensor holder from the electrical box and remove the thermistor from the holder.

4. Removing the fan motor and right side fan

- (1) Remove the air intake grille. (See Figure 1, 2)
- (2) Remove the screw from the beam and remove the beam. (See Photo 1)
- (3) Remove 2 screws from the electrical cover, and remove the electrical cover.
- (4) Remove 2 screws from the electrical box and pull the electrical box downward.
- (5) Temporarily secure the electrical box using 2 hooks in the back of electrical box.
- (6) Remove 4 screws fixing fan guard of the fan motor. (2 screws : See Photo 5 / 2 screws : Upper the electrical box)
- (7) Remove 2 screws fixing fan guard of piping side and remove the fan guard. (See Photo 6)
- (8) Remove the lower casing while pressing the 4 catches of the casing (right side of the fan motor).
- (9) Loosen the 2 set screws (2 hexagon set screws) of connecting joint and slide the fan motor to the left. (See Photo 5)
- (10) Remove the motor piece (left and right, each 1 screw). (See Photo 5)
- (11) Remove the fan motor and right side fan together.
- (12) Loosen the set screw (hexagon set screw) of fan and remove the fan from the shaft. (See Photo 7, 8)

Photo 8

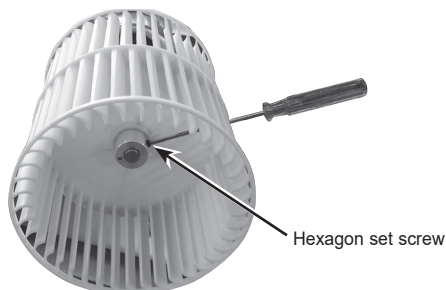

PHOTOS/FIGURES

Photo 4

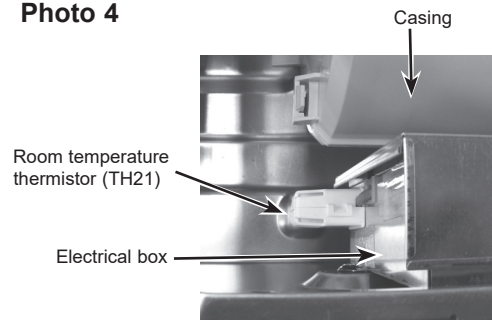

Photo 5

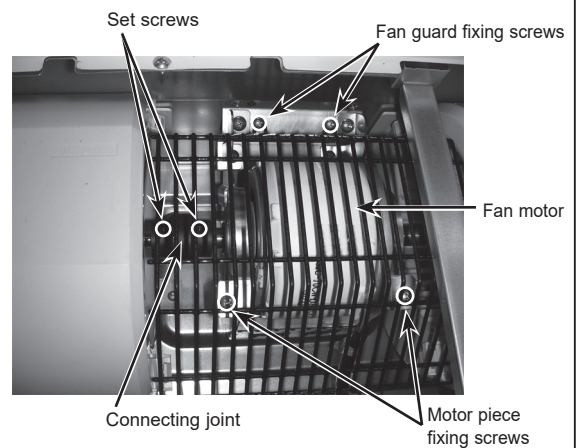

Photo 6

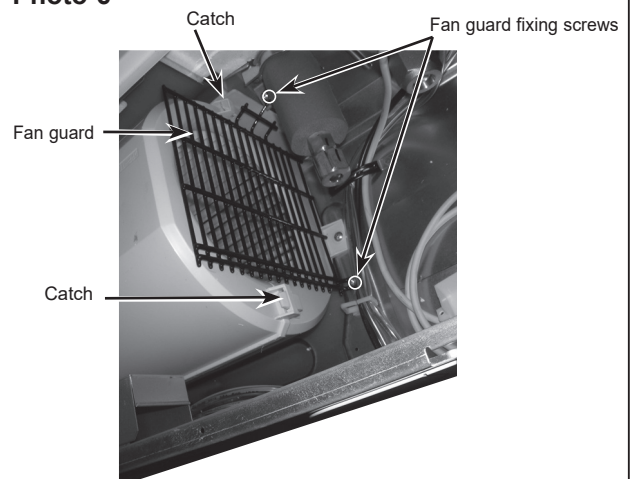
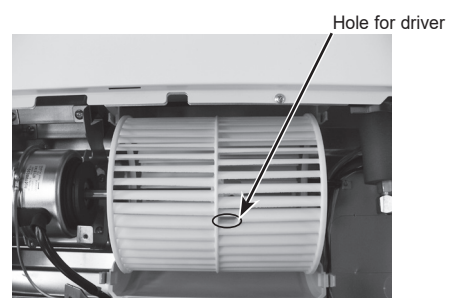

Photo 7



OPERATING PROCEDURE

5. Removing the fan (3 connection)

- (1) Remove the air intake grille. (See Figure 1, 2)
- (2) Remove the screw from the beam and remove the beam. (See Photo 1)
- (3) Remove 2 screws from the electrical cover, and remove the electrical cover.
- (4) Remove 2 screws from the electrical box and pull the electrical box downward. Temporarily secure the electrical box using 2 hooks in the back of electrical box.
- (5) Remove 4 screws from the fan guard of the fan motor. (See Photo 5)
- (6) Remove 2 screws from the left side beam and remove the beam. (See Photo 1)
- (7) Remove the 3 screws from center fan guard and remove the fan guard. (2 screws : See Photo 9 / 1 screw : Drain pan side)
- (8) Remove 2 screws from the left fan guard and remove the fan guard. (See Photo 10)
- (9) Loosen 2 set screws (2 hexagon set screws) of connecting joint. (See Photo 5)
- (10) Remove 3 lower casings while pressing each 4 catches of the casing.
- (11) Remove the 4 screws from the bearing support. (See Photo 11)
- (12) Slide the connecting joint to the left and remove the fans and shaft together. (See Photo 12)
- (13) Remove the fan from the shaft. (See Photo 7, 8)

Photo 12

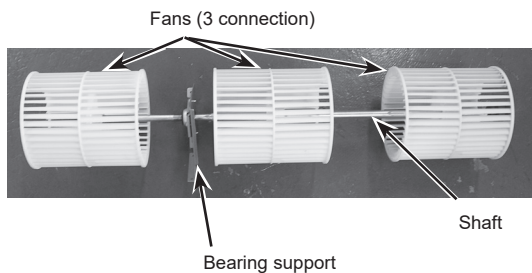

6. Removing the side panel

- (1) Remove the air intake grille. (See Figure 1, 2)
- (2) Remove the screw from the side panel, and remove the side panel by sliding the panel to the front.

PHOTOS/FIGURES

Photo 9

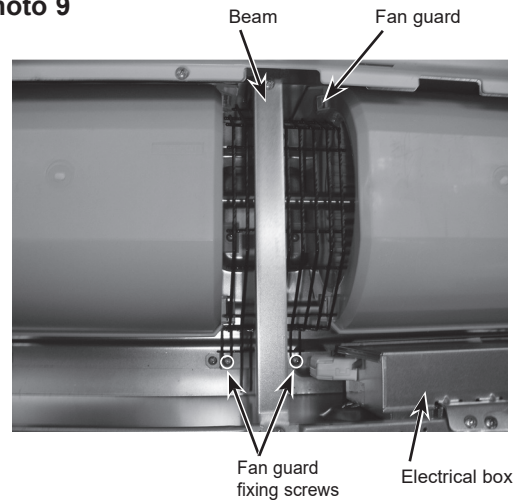

Photo 10

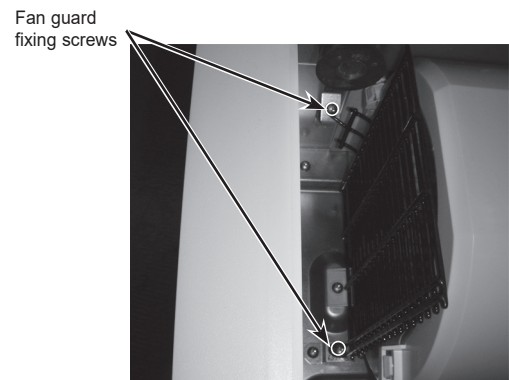

Photo 11

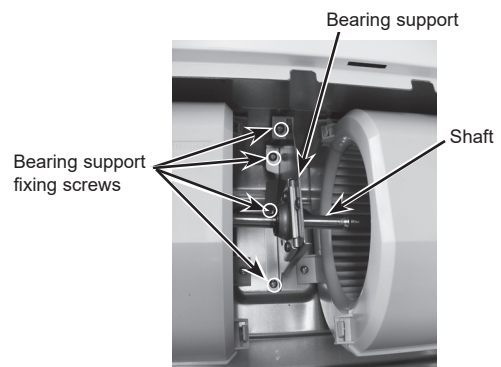
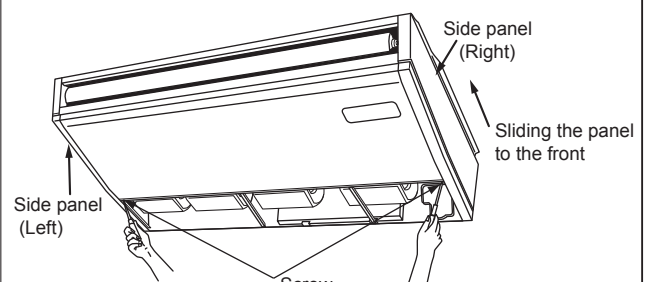

Figure 3



OPERATING PROCEDURE

7-1. Removing the vane motor

- (1) Remove the air intake. (See Figure 1, 2)
- (2) Remove the right side panel. (See Figure 3)
- (3) Remove the connector of vane motor.
- (4) Remove 2 screws of vane motor cover, then remove vane motor.

7-2. Removing the R32 sensor

- (1) Remove the air intake. (See Figure 1, 2)
- (2) Remove the right side panel. (See Figure 3)
- (3) Remove the screw of R32 sensor.
- (4) Disconnect the connector CNSA from the indoor controller board.

8. Removing the under panel

- (1) Remove the air intake grille. (See Figure 1, 2)
- (2) Remove the left and right side panels. (See Figure 3)
- (3) Remove the beam. (See Photo 1)
- (4) Remove the electrical cover. (See Photo 1)
- (5) Pull the electrical box downward. (See Photo 2)
- (6) (Wireless remote controller receiver type only)
Disconnect the connector CNB from the PCB for wireless remote controller and remove the clamp and strap for wires.
- (7) Remove 8 screws from the under panel.
- (8) Move the under panel forward by about 10mm and remove the under panel.

9. Removing the drain pan

- (1) Remove the air intake grille. (See Figure 1, 2)
- (2) Remove the side panel (right and left). (See Figure 3)
- (3) Remove the under panel. (See Photo 14)
Remove the screws of the right and left side drain pan. (See Photo 15)
- (4) Remove 2 insulation in center of the drain pan, and after removing 2 screws with washer, remove the drain pan. (See Photo 16, 17)

(Note)

Please be aware that there might be some drainage left in the drain pan when you remove the drain pan.

Photo 17

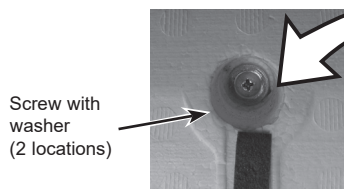

PHOTOS/FIGURES

Photo 13

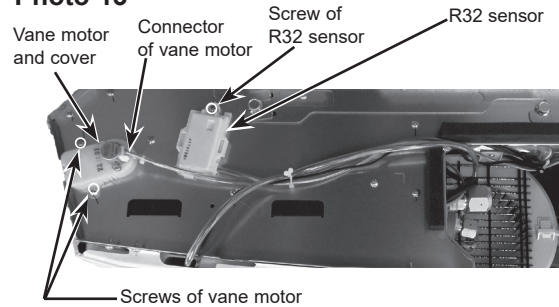

Photo 14

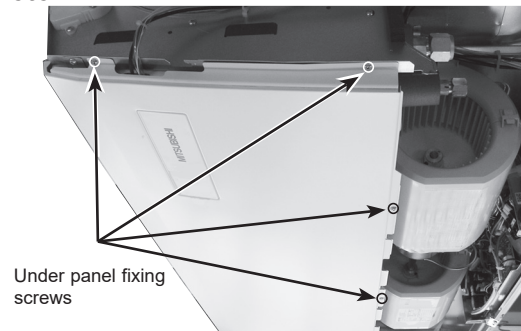

Photo 15

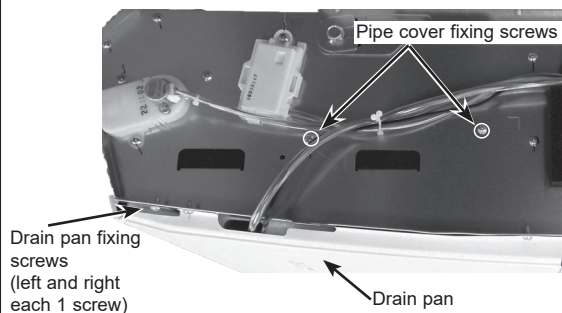
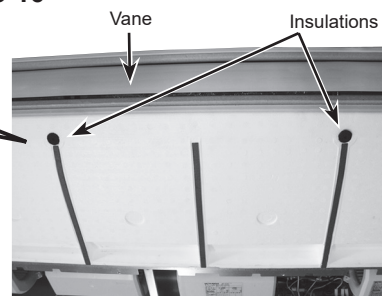
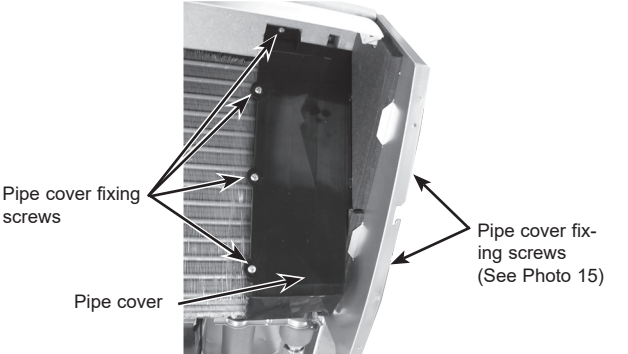
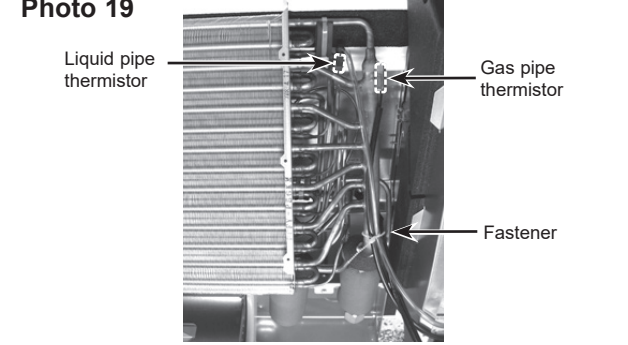
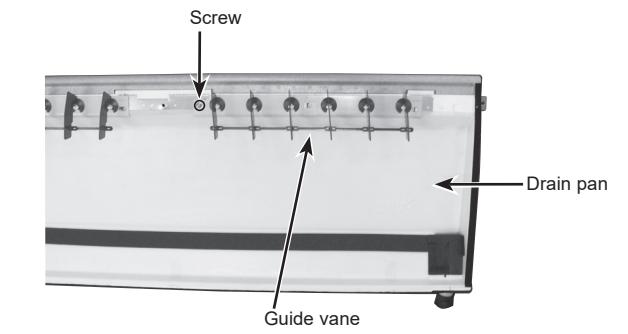
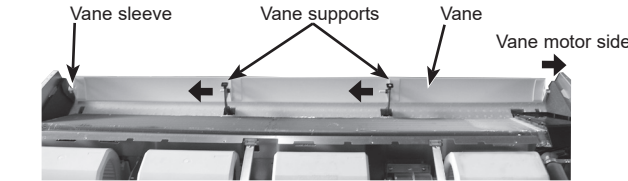

Photo 16





OPERATING PROCEDURE	PHOTOS/FIGURES
<p>10. Removing the pipe thermistors / Liquid (TH22) and Gas (TH23)</p> <ol style="list-style-type: none"> (1) Remove the air intake grille. (See Figure 1, 2) (2) Remove the left and right side panels. (See Figure 3) (3) Remove the under panel. (See Photo 14) (4) Remove the drain pan. (See Photo 15, 16, 17) (5) Disconnect the connector CN44 (white) from the indoor controller board. (6) Remove 6 screws from the pipe cover and remove the pipe cover. (See Photo 15, 18) (7) Remove the fastener for wires and remove the thermistors (liquid and gas) from each holder. (See Photo 19) 	<p>Photo 18</p>  <p>Photo 19</p> 
<p>11. Removing the guide vane</p> <ol style="list-style-type: none"> (1) Remove the intake grille. (See Figure 1, 2) (2) Remove the side panel (right and left). (See Figure 3) (3) Remove the under panel. (See Photo 14) (4) Remove the drain pan. (See Photo 15, 16, 17) (5) Remove the screw from the guide vane, then remove the guide vane. 	<p>Photo 20</p> 
<p>12. Removing the Auto vane</p> <ol style="list-style-type: none"> (1) Remove the intake grille. (See Figure 1, 2) (2) Remove the right side panel. (See Figure 3) (3) Remove the vane motor and cover. (See Photo 13) (4) Slide the auto vane to the vane motor side. (5) Remove 2 axes from each vane support pushing the vane support to the vane sleeve side. 	<p>Photo 21</p> 

OPERATING PROCEDURE

13. Removing the heat exchanger, LEV and LEV coil

- (1) Remove the air intake grille. (See Figure 1, 2)
- (2) Remove the beam. (See Photo 1)
- (3) Remove the electrical cover. (See Photo 1)
- (4) Pull the electrical box downward. (See Photo 2)
- (5) Disconnect the connector CN60 from the indoor controller board.
- (6) Remove the left and right side panels. (See Figure 3)
- (7) Remove the under panel. (See Photo 14)
- (8) Remove the drain pan. (See Photo 15, 16, 17)
- (9) Remove the pipe cover. (See Photo 18)
- (10) Remove the pipe thermistors (TH22 and TH23) from each holder. (See Photo 19)
- (11) Remove the pipe band fixing screw and remove the pipe band. (See Photo 22)
- (12) Remove 2 screws from the heat exchanger and remove the heat exchanger with LEV. (See Photo 23)
- (13) Remove the band. (See Photo 24)
- (14) Remove the LEV coil. (See Photo 24)

PHOTOS/FIGURES

Photo 22

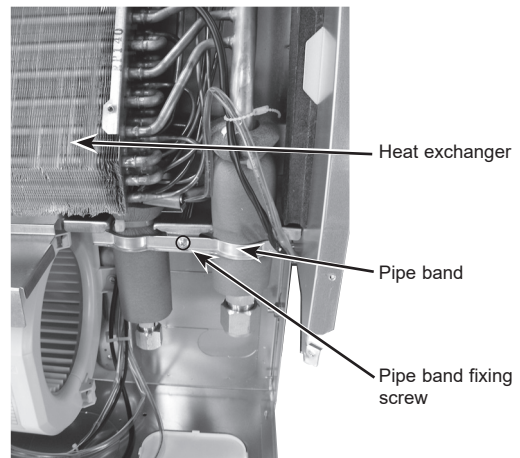

Photo 23

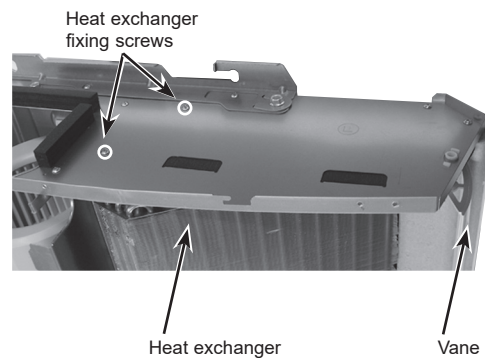
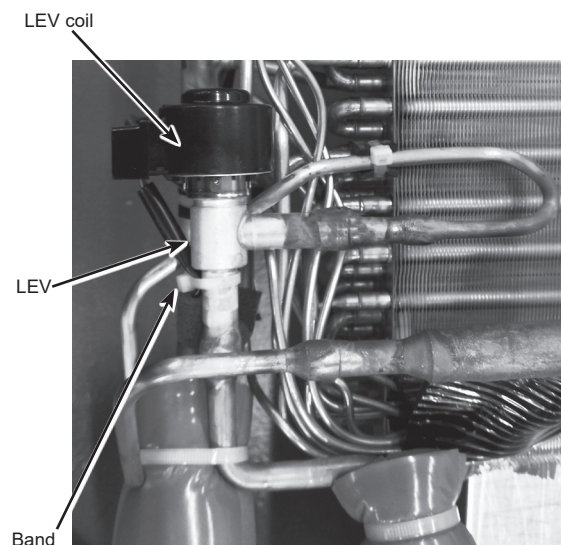

Photo 24



9-1. REMOTE CONTROLLER FUNCTIONS

<PAR-41MAAB>

Controller interface

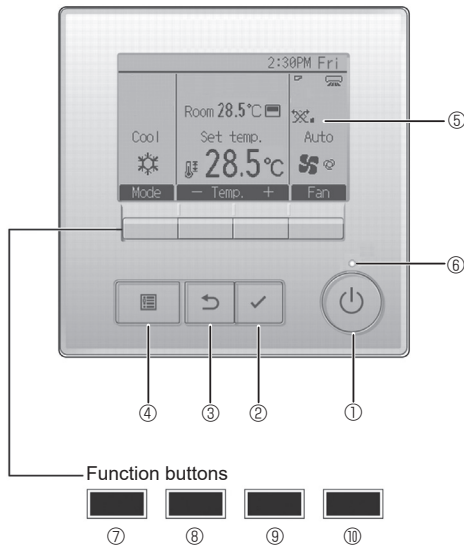

① [ON/OFF] button

Press to turn ON/OFF the indoor unit.

② [SELECT] button

Press to save the setting.

③ [RETURN] button

Press to return to the previous screen.

④ [MENU] button

Press to bring up the Main menu.

⑤ Backlit LCD

Operation settings will appear.

When the backlight is off, pressing any button turns the backlight on and it will stay lit for a certain period of time depending on the screen.

When the backlight is off, pressing any button turns the backlight on and does not perform its function. (except for the [ON/OFF] button)

The functions of the function buttons change depending on the screen.

Refer to the button function guide that appears at the bottom of the LCD for the functions they serve on a given screen.

When the system is centrally controlled, the button function guide that corresponds to the locked button will not appear.

Main display

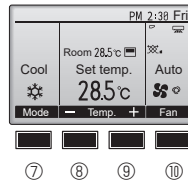

Main menu

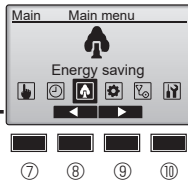

Menu screen

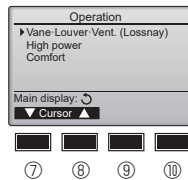

Function guide

⑥ ON/OFF lamp

This lamp lights up in green while the unit is in operation. It blinks while the remote controller is starting up or when there is an error.

⑦ Function button [F1]

Main display: Press to change the operation mode.

Menu screen: The button function varies with the screen.

⑧ Function button [F2]

Main display: Press to decrease temperature.

Main menu: Press to move the cursor left.

Menu screen: The button function varies with the screen.

⑨ Function button [F3]

Main display: Press to increase temperature.

Main menu: Press to move the cursor right.

Menu screen: The button function varies with the screen.

⑩ Function button [F4]

Main display: Press to change the fan speed.

Menu screen: The button function varies with the screen.

Display

The main display can be displayed in two different modes: "Full" and "Basic". The initial setting is "Full". To switch to the "Basic" mode, change the setting on the Main display setting. (Refer to operation manual included with remote controller.)

<Full mode>

* All icons are displayed for explanation.

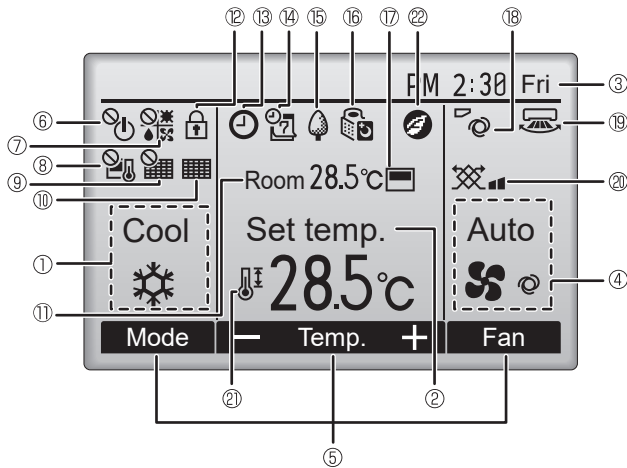

<Basic mode>

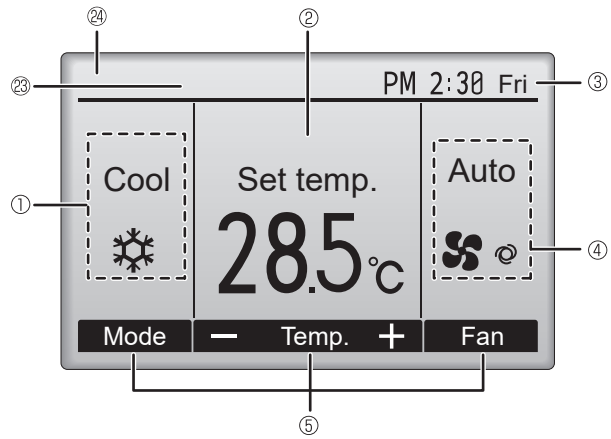

① Operation mode

② Preset temperature

③ Clock

④ Fan speed

⑤ Button function guide

Functions of the corresponding buttons appear here.



Appears when the ON/OFF operation is centrally controlled.



Appears when the operation mode is centrally controlled.



Appears when the preset temperature is centrally controlled.



Appears when the filter reset function is centrally controlled.



Indicates when filter needs maintenance.

⑪ Room temperature



Appears when the buttons are locked.



Appears when the On/Off timer, Night setback, or Auto-off timer function is enabled.

appears when the timer is disabled by the centralized control system.



Appears when the Weekly timer is enabled.



Appears while the units are operated in the energy saving mode. (Will not appear on some models of indoor units)



Appears while the outdoor units are operated in the silent mode.



Appears when the built-in thermistor on the remote controller is activated to monitor the room temperature (⑪).

appears when the thermistor on the indoor unit is activated to monitor the room temperature.



Indicates the vane setting.



Indicates the louver setting.



Indicates the ventilation setting.



Appears when the preset temperature range is restricted.



Appears when an energy saving operation is performed using a "3D i-see Sensor" function.

⑳ Centrally controlled

Appears for a certain period of time when a centrally-controlled item is operated.

㉑ Preliminary error display

A check code appears during the preliminary error.

Most settings (except ON/OFF, mode, fan speed, temperature) can be made from the Main menu.

*1 These functions are not applied to the floor standing models.

Menu structure

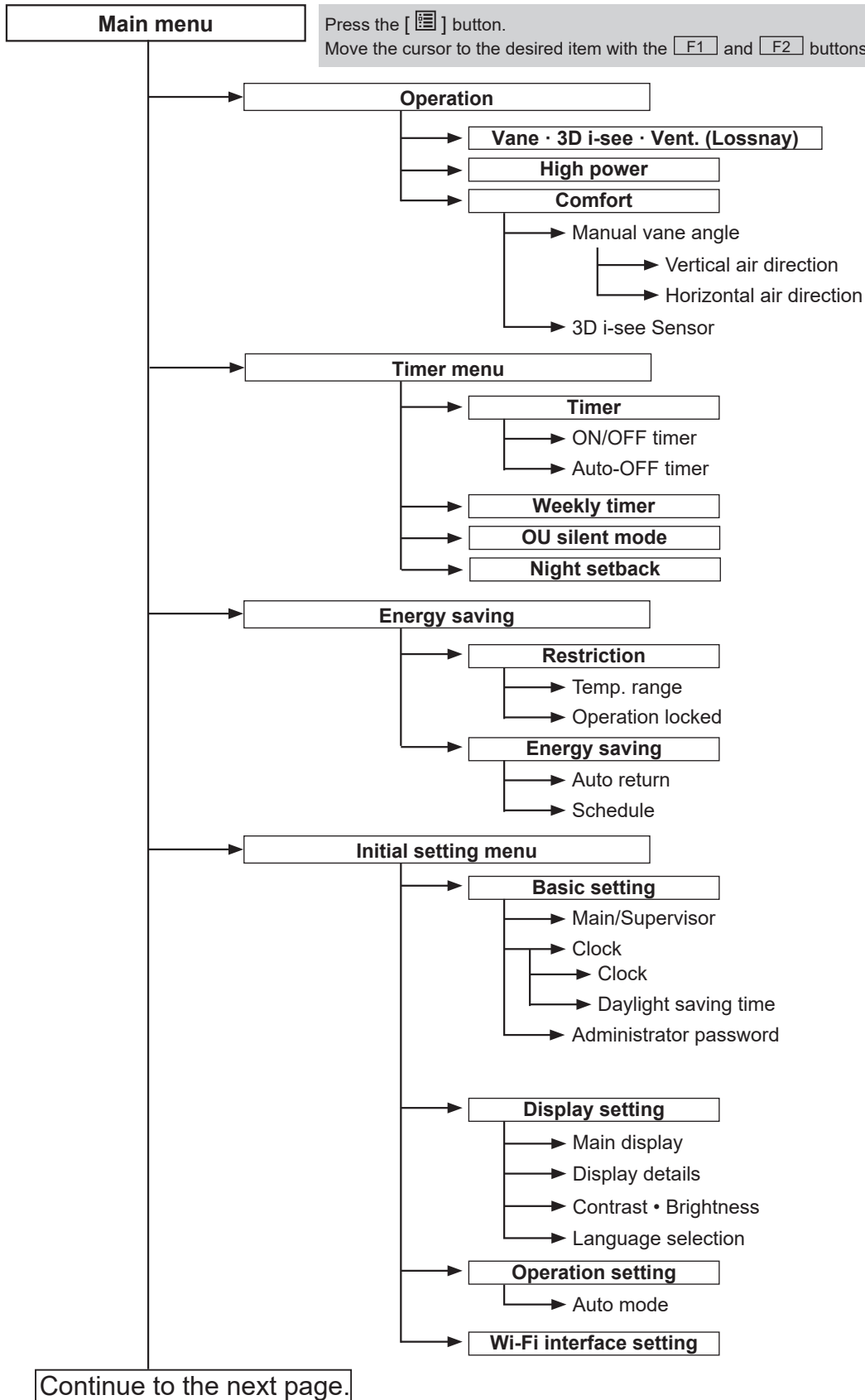

Not all functions are available on all models of indoor units.

Continue from the previous page.

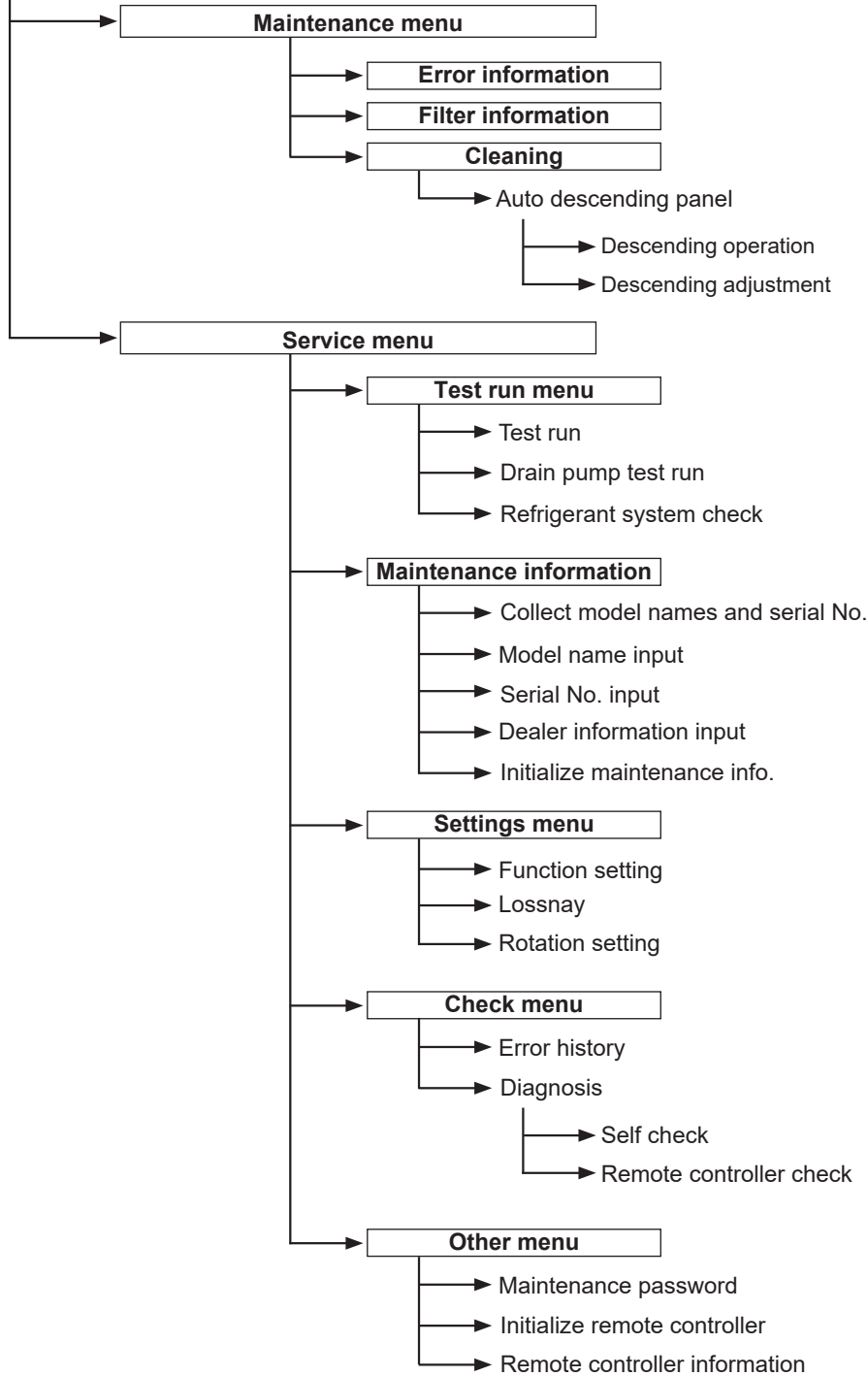

Not all functions are available on all models of indoor units.

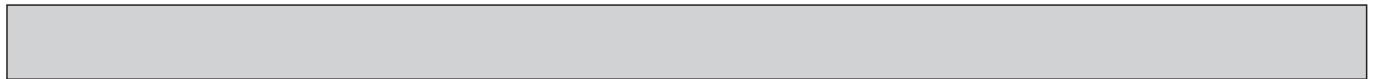

Main menu list

Main menu	Setting and display items		Setting details
Operation	Vane · 3D i-see · Vent. (Vane.Vent. (Lossnay))		Vane: Use to set the vertical air direction. Louver: Use to set the horizontal air direction. 3D i-see Sensor: This setting is available only for the air conditioners that support easy setting function of motion sensing air direction. Vent: Use to set the amount of ventilation.
	High power ^{*3}		Use to reach the comfortable room temperature quickly. • Units can be operated in the High-power mode for up to 30 minutes.
	Comfort	Manual vane angle	Vertical air direction • Sets the vertical airflow direction (vane) of each unit. Horizontal air direction • Sets the horizontal airflow direction (vane) of each unit.
		3D i-see Sensor	Use to set the following functions for 3D i-see Sensor. • Air distribution • Energy saving option • Seasonal airflow
Timer	Timer	ON/OFF timer ^{*1}	Use to set the operation ON/OFF times. • Time can be set in 5-minute increments.
		Auto-OFF timer	Use to set the Auto-OFF time. • Time can be set to a value from 30 to 240 in 10-minute increments.
	Weekly timer ^{*1, *2}		Use to set the weekly operation ON/OFF times. • Up to 8 operation patterns can be set for each day. (Not valid when the ON/OFF timer is enabled.)
	OU silent mode ^{*1, *3}		Use to set the time periods in which priority is given to quiet operation of outdoor units over temperature control. Set the Start/Stop times for each day of the week. • Select the desired silent level from "Normal," "Middle," and "Quiet."
	Night setback ^{*1}		Use to make Night setback settings. • Select "Yes" to enable the setting, and "No" to disable the setting. The temperature range and the start/stop times can be set.
Energy saving	Restriction	Temp. range ^{*2}	Use to restrict the preset temperature range. • Different temperature ranges can be set for different operation modes.
		Operation lock	Use to lock selected functions. • The locked functions cannot be operated.
	Energy saving	Auto return ^{*2}	Use to get the units to operate at the preset temperature after performing energy saving operation for a specified time period. • Time can be set to a value from 30 and 120 in 10-minute increments. (This function will not be valid when the preset temperature ranges are restricted.)
		Schedule ^{*1, *3}	Set the start/stop times to operate the units in the energy saving mode for each day of the week, and set the energy saving rate. • Up to 4 energy saving operation patterns can be set for each day. • Time can be set in 5-minute increments. • Energy saving rate can be set to a value from 0% or 50 to 90% in 10% increments.
	Energy data (for unit time, month, and day)		Displays the amount of power consumption during operation. • Unit time data: Data for the last one-month period can be displayed in 30-minute units. • Monthly/daily data: Data for the last 14-month period are displayed in day-and-month-units. * Data can be deleted. * Data are obtained based on the power consumption estimated from the operating state.

^{*1} Clock setting is required.

^{*2} 1°C increments.

^{*3} This function is available only when certain outdoor units are connected.



Main menu	Setting and display items		Setting details
Initial setting	Basic setting	Main/Supervisor	For a system that requires supervisor remote controller, set the remote controller to "Supervisor" from this setting.
		Clock	Use to set the current time.
		Daylight saving time	Set the daylight saving time.
		Administrator password	The administrator password is required to make the settings for the following items. • Timer setting • Energy saving setting • Weekly timer setting • Restriction setting • Outdoor unit silent mode setting • Night set back
	Display setting	Main display	Use to switch between "Full" and "Basic" modes for the Main display, and use to change the background colors of the display to black.
		Display details	Make the settings for the remote controller related items as necessary. Clock: The initial settings are "Yes" and "24h" format. Temperature: Set either Celsius (°C) or Fahrenheit (°F). Room temp.: Set Show or Hide. Auto mode: Set Auto mode display or Only Auto display.
		Contrast • Brightness	Use to adjust screen contrast and brightness.
	Language selection	Use to select the desired language.	
Operation setting	Auto mode	Whether or not to use Auto mode can be selected by using the button. This setting is valid only when indoor units with Auto mode function are connected.	
Maintenance	Error information		Use to check error information when an error occurs. • Check code, error source, refrigerant address, model name, manufacturing number, contact information (dealer's phone number) can be displayed. (The model name, manufacturing number, and contact information need to be registered in advance to be displayed.)
	Filter information		Use to check the filter status. • The filter sign can be reset.
	Cleaning	Auto descending panel	Use to lift and lower the auto descending panel (Optional parts).
Service	Test run		Select "Test run" from the Service menu to bring up the Test run menu. • Test run • Drain pump test run • Refrigerant system check
	Input maintenance info.		Select "Input maintenance Info." from the Service menu to bring up the Maintenance information screen. The following settings can be made from the Maintenance Information screen. • Model name input • Serial No. input • Dealer information input • Initialize maintenance info.
	Settings	Function setting	Make the settings for the indoor unit functions via the remote controller as necessary.
		LOSSNAY setting	This setting is required only when the operation of CITY MULTI units is interlocked with LOSSNAY units.
	Check	Error history	Display the error history and execute "delete error history".
		Diagnosis	Self check: Error history of each unit can be checked via the remote controller. Remote controller check: When the remote controller does not work properly, use the remote controller checking function to troubleshoot the problem.
	Others	Maintenance password	Use to change the maintenance password.
		Initialize remote controller	Use to initialize the remote controller to the factory shipment status.
Remote controller information		Use to display the remote controller model name, software version, and serial number.	

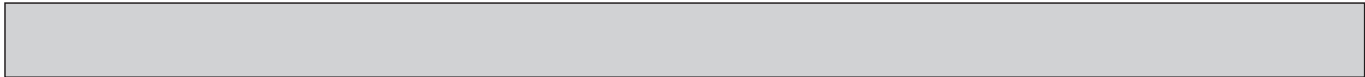

<PAR-SL101A-E>

Controller interface

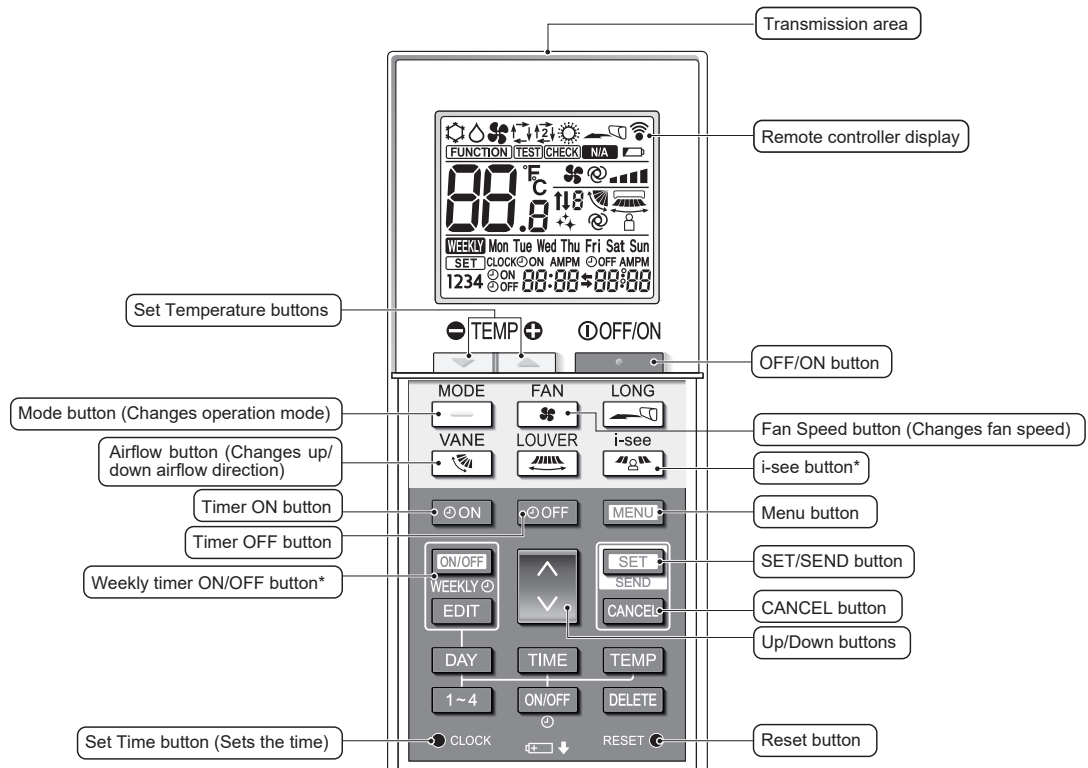

Note:

* This button is enabled or disabled depending on the model of the indoor unit.

Display

Operation mode

	Cool		Dry
	Fan		Auto (single set point)
	Heat		Auto (dual set point)

Temperature setting

The units of temperature can be changed. For details, refer to the Installation Manual.

Vane setting

Step 1 Step 2 Step 3 Step 4 Step 5 Swing Auto

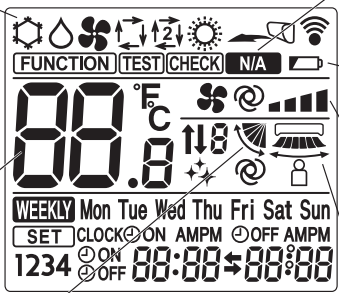

Not available

Appears when a non-supported function is selected.

Battery replacement indicator

Appears when the remaining battery power is low.

Fan speed setting

Auto

3D i-see Sensor (Air distribution)

Default Direct Indirect

When Direct or Indirect is selected, the vane setting is set to "Auto".

9-2. ERROR INFORMATION

**When an error occurs, the following screen will appear.
Check the error status, stop the operation, and consult your dealer.**

1. Check code, error unit, refrigerant address, date and time of occurrence, model name, and serial number will appear.
The model name and serial number will appear only if the information have been registered.

Press the **F1** or **F2** button to go to the next page.

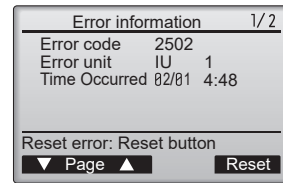

Contact information (dealer's phone number) will appear if the information has been registered.

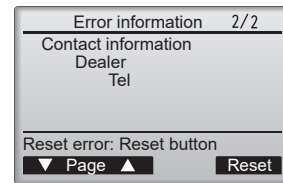

2. Press the **F4** button or the  button to reset the error that is occurring.

Errors cannot be reset while the ON/OFF operation is prohibited.

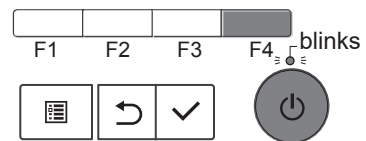
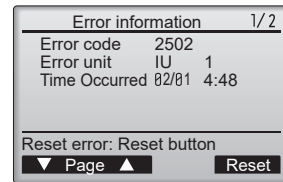

Select "OK" with the **F4** button.

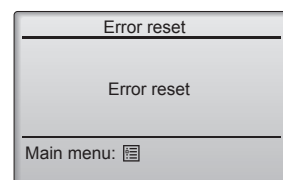
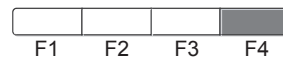
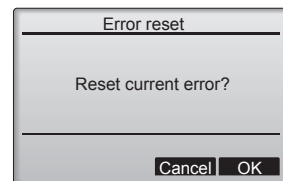

Navigating through the screens

- To go back to the Service menu [] button

• Checking the error information

While no errors are occurring, page 2/2 of the error information can be viewed by selecting "Error information" from the Maintenance menu. Errors cannot be reset from this screen.

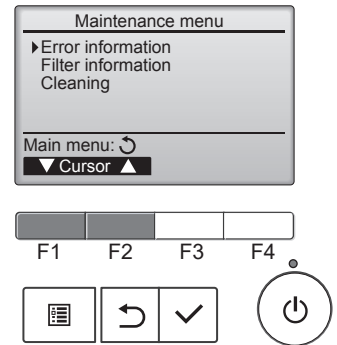

9-3. SERVICE MENU

Maintenance password is required

1. Select "Service" from the Main menu, and press the [✓] button.

*At the main display, the menu button and select "Service" to make the maintenance setting.

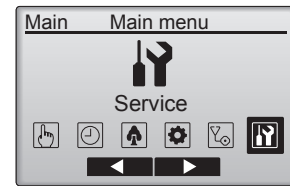

2. When the Service menu is selected, a window will appear asking for the password.

To enter the current maintenance password (4 numerical digits), move the cursor to the digit you want to change with the [F1] or [F2] button.



Set each number (0 through 9) with the [F3] or [F4] button.



Then, press the [✓] button.

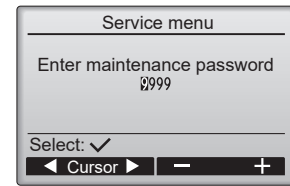

Note: The initial maintenance password is "9999". Change the default password as necessary to prevent unauthorized access. Have the password available for those who need it.
If you forget your maintenance password, you can initialize the password to the default password "9999" by pressing and holding the [F1] button for 10 seconds on the maintenance password setting screen.



3. If the password matches, the Service menu will appear.

Note: Air conditioning units may need to be stopped to make only at "Settings". There may be some settings that cannot be made when the system is centrally controlled.



A screen will appear that indicates the setting has been saved.

Navigating through the screens

- To go back to the Service menu[] button
- To return to the previous screen.....[] button

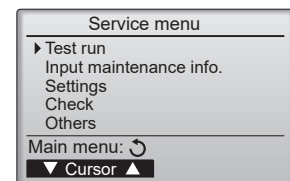

9-4. TEST RUN

9-4-1. PAR-41MAAB

1. Select "Service" from the Main menu, and press the [✓] button.



Select "Test run" with the [F1] or [F2] button, and press the [✓] button.

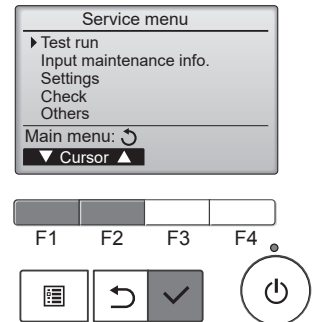

2. Select "Test run" with the [F1] or [F2] button, and press the [✓] button.

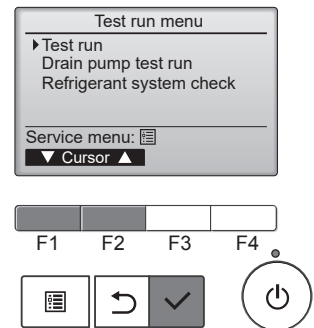

Test run operation

Press the [F1] button to go through the operation modes in the order of "Cool and Heat".

Cool mode: Check the cold air blows out.
Heat mode: Check the heat blows out.

Check the operation of the outdoor unit's fan.



Press the [✓] button and open the Vane setting screen.

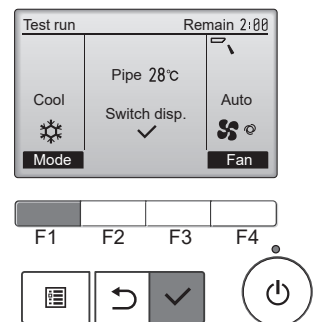

Auto vane check

Check the auto vane with the [F1] [F2] [F3] buttons.



Press the [↻] button to return to "Test run operation".









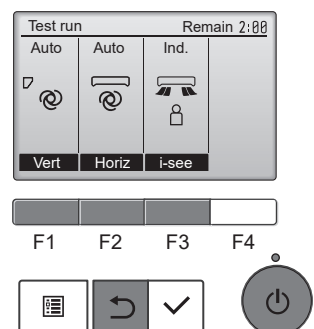



Press the [⏻] button.

When the test run is completed, the "Test run menu" screen will appear.
The test run will automatically stop after 2 hours.

*The function is available only for the model with vanes.



9-4-2. PAR-SL101A-E

1. Press the  button ① to stop the air conditioner.
 - If the weekly timer is enabled (**WEEKLY** is on), press the  button ③ to disable it (**WEEKLY** is off).
2. Press the  button ② for 5 seconds.
 - **CHECK** comes on and the unit enters the service mode.
3. Press the  button ②.
 - **TEST**  comes on and the unit enters the test run mode.
4. Press the following buttons to start the test run.
 - : Switch the operation mode between cooling and heating and start the test run.
 - : Switch the fan speed and start the test run.
 - : Switch the airflow direction and start the test run.
 - : Switch the louver and start the test run.
 - : Start the test run.
5. Stop the test run.
 - Press the  button ① to stop the test run.
 - After 2 hours, the stop signal is transmitted.

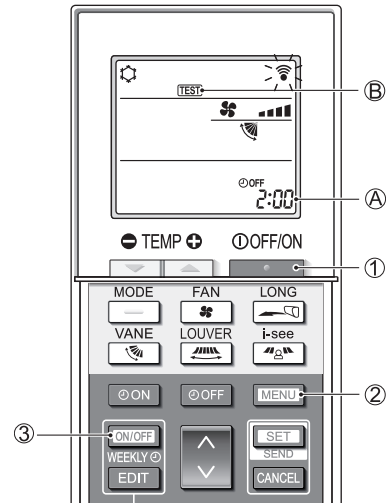

9-5. FUNCTION SETTING

9-5-1. PAR-41MAAB

1. Select "Service" from the Main menu, and press the [✓] button.



Select "Setting" from the Service menu, and press the [✓] button.



Select "Function setting", and press the [✓] button.

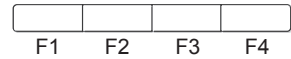
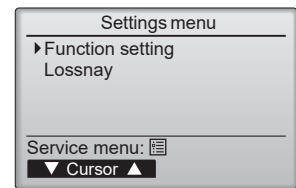

2. The Function setting screen will appear.

Press the [F1] or [F2] button to move the cursor to one of the following: M-NET address, function setting number, or setting value. Then, press the [F3] or [F4] button to change the settings to the desired settings.



Once the settings have been completed, press the [✓] button.

A screen will appear indicating that the settings information is being sent.

To check the current settings of a given unit, enter the setting for its M-NET address and function setting number, select Conf for the Function, and press the [✓] button.

A screen will appear indicating that the settings are being searched for.

When the search is done, the current settings will appear.



When the settings information has been sent, a screen will appear indicating its completion.

To make additional settings, press the [↻] button to return to the screen shown in the above step. Set the function numbers for other indoor units by following the same steps.

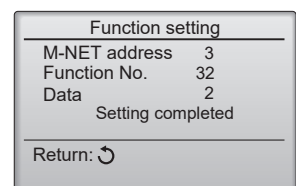
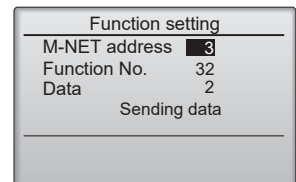
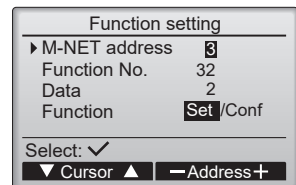

Note:

- Refer to the indoor unit Installation Manual for information about the factory settings of indoor units, function setting numbers, and setting values.
- Be sure to write down the settings for all functions if any of the initial settings has been changed after the completion of installation work.

9-6. ERROR HISTORY

1. Select "Service" from the Main menu, and press the [✓] button.



Select "Check" with the [F1] or [F2] button, and press the [✓] button.

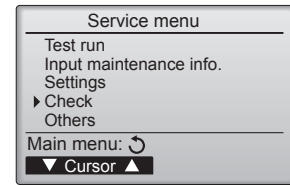

2. Select "Error history" with the [F1] or [F2] button, and press the [✓] button.

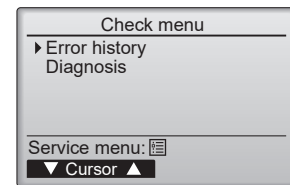

3. 16 error history records will appear.

4 records are shown per page, and the top record on the first page indicates the latest error record.

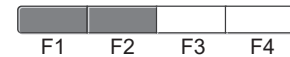
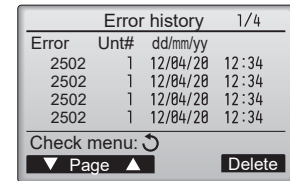

4. Deleting the error history

To delete the error history, press the [F4] button (Delete) on the screen that shows error history.
A confirmation screen will appear asking if you want to delete the error history.



Press the [F4] button (OK) to delete the history.



"Error history deleted" will appear on the screen.

Press the [↻] button to go back to the Check menu screen.

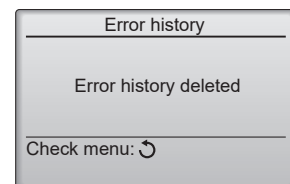
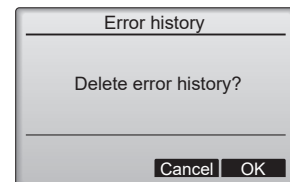

9-7. SELF-DIAGNOSIS

9-7-1. PAR-41MAAB

1. Select "Service" from the Main menu, and press the [✓] button.

Select "Check" from the Service menu, and press the [✓] button.

Select "Diagnosis" from the Check menu, and press the [✓] button.

Select "Self check" with the [F1] or [F2] button, and press the [✓] button.

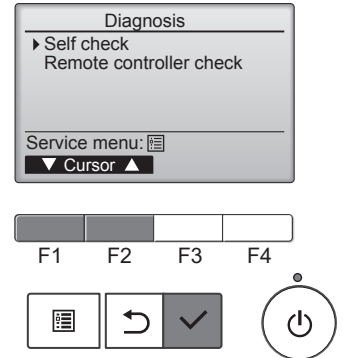

2. Select "Self check" from the Diagnosis menu, and press the [✓] button to view the Self check screen.

With the [F1] or [F2] button, enter the M-NET address, and press the [✓] button.

Check code, unit number, attribute, and indoor unit demand signal ON/OFF status at the contact will appear. "-" will appear if no error history is available.

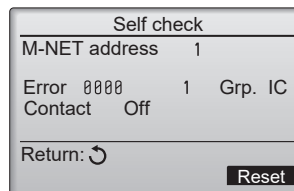
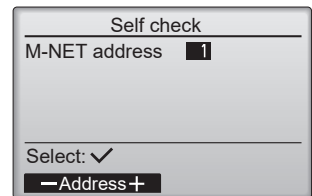

When there is no error history

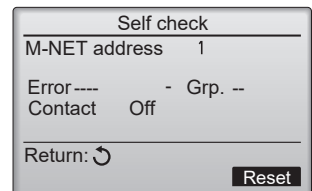

3. Resetting the error history

Press the [F4] button (Reset) on the screen that shows the error history. A confirmation screen will appear asking if you want to delete the error history.

Press the [F4] button (OK) to delete the error history. If deletion fails, "Request rejected" will appear, and "Unit not exist" will appear if indoor units that correspond to the entered address are not found.

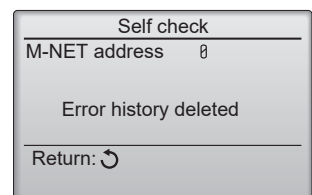
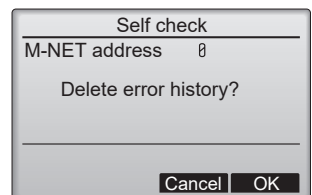

9-7-2. PAR-SL101A-E

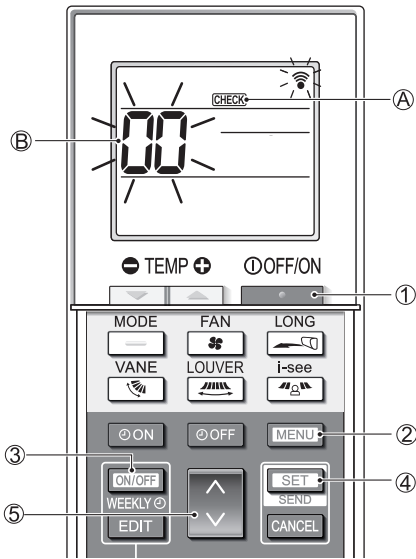

[Procedure]

1. Press the button ① to stop the air conditioner.
 - If the weekly timer is enabled (**WEEKLY** is on), press the button ③ to disable it (**WEEKLY** is off).
2. Press the button ② for 5 seconds.
 - **CHECK** ① comes on and the unit enters the self-check mode.
3. Press the button ⑤ to select the refrigerant address (M-NET address) ② of the indoor unit for which you want to perform the self-check.
4. Press the button ④.
 - If an error is detected, the check code is indicated by the number of beeps from the indoor unit and the number of blinks of the OPERATION INDICATOR lamp.
5. Press the button ①.
 - **CHECK** ① and the refrigerant address (M-NET address) ② go off and the self-check is completed.

9-8. REMOTE CONTROLLER CHECK

If operations cannot be completed with the remote controller, diagnose the remote controller with this function.

1. Select "Service" from the Main menu, and press the [✓] button.



Select "Check" from the Service menu, and press the [✓] button.



Select "Diagnosis" from the Check menu, and press the [✓] button.



Select "Remote controller check" with the [F1] or [F2] button, and press the [✓] button.

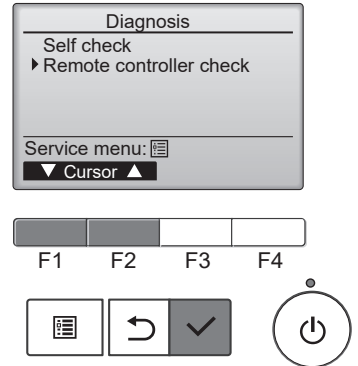

2. Select "Remote controller check" from the Diagnosis menu, and press the [✓] button to start the remote controller check and see the check results.



To cancel the remote controller check and exit the "Remote controller check" menu screen, press the [List] or the [Refresh] button.



The remote controller will not reboot itself.

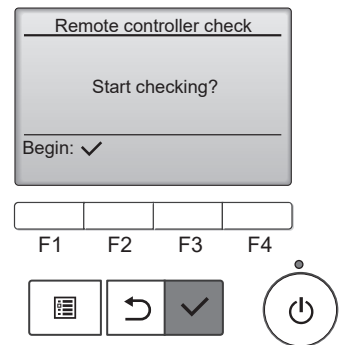

3.
 - OK: No problems are found with the remote controller. Check other parts for problems.
 - E3, 6832: There is noise on the transmission line, or the indoor unit or another remote controller is faulty. Check the transmission line and the other remote controllers.
 - NG (ALL0, ALL1): Send-receive circuit fault. The remote controller needs replacing.
 - ERC: The number of data errors is the discrepancy between the number of bits in the data transmitted from the remote controller and that of the data that was actually transmitted over the transmission line. If data errors are found, check the transmission line for external noise interference.



If the [✓] button is pressed after the remote controller check results are displayed, remote controller check will end, and the remote controller will automatically reboot itself.

Remote controller check results screen

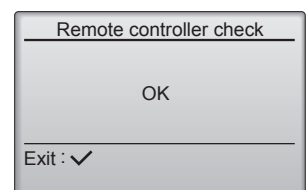

Check the remote controller display and see if anything is displayed (including lines). Nothing will appear on the remote controller display if the correct voltage (8.5–12 VDC) is not supplied to the remote controller. If this is the case, check the remote controller wiring and indoor units.

CITY MULTI

mitsubishi electric corporation

HEAD OFFICE: TOKYO BUILDING, 2-7-3, MARUNOUCHI, CHIYODA-KU, TOKYO100-8310, JAPAN
