

AIR CONDITIONING SYSTEMS

HYBRID
CITY MULTI



DATA BOOK

MODEL

CMB-WM-V-AA

CMB-WM-F-AA

CMB-WM-V-BB

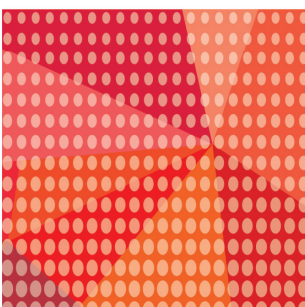

CMB-WM-V-AA, CMB-WM-F-AA, CMB-WM-V-BB

1. SPECIFICATIONS	2
2. EXTERNAL DIMENSIONS	8
3. CENTER OF GRAVITY	14
4. ELECTRICAL WIRING DIAGRAMS	15
5. SOUND LEVELS	20
5-1. Sound levels	20
5-2. NC curves	20
6. ELECTRICAL CHARACTERISTICS	21
7. SYSTEM DESIGN	22
7-1. Compatibility	22

1. SPECIFICATIONS

HBC controller

HBC controller

Model		CMB-WM108V-AA							
Number of branch		8							
Power source		1-phase 220-230-240 V							
		50 Hz			60 Hz				
Power input (220-230-240)	Cooling	kW	0.45-0.46-0.47			0.45-0.46-0.47			
	Heating	kW	0.45-0.46-0.47			0.45-0.46-0.47			
Current input (220-230-240)	Cooling	A	2.89-2.83-2.79			2.89-2.83-2.79			
	Heating	A	2.89-2.83-2.79			2.89-2.83-2.79			
Sound pressure level (measured in anechoic room) *21		dB <A>	41						
Applicable temperature range of installation site *22		°C (D.B.)	0 to 32						
External finish		Galvanized steel plate (Drain pan: Pre-coated galvanized sheets + powder coating)							
Connectable outdoor/heat source unit model		PURY- (E)P200~500YNW-A/A1/A2 (-BS) PURY- (E)M200~500YNW-A/A1 (-BS) PURY- (E)P200~500YLM-A1 (-BS),PQRY-P200~500YLM-A1/A2							
Indoor unit capacity connectable to 1 branch		Model WP/W/L80 or smaller (Use optional joint pipe combining 2 branches when the total unit capacity exceeds WP/W/L81.)							
External dimension H × W × D		mm	300 x 1,520 x 630						
		in.	11-13/16 x 59-7/8 x 24-13/16						
Refrigerant *23 piping diameter	To outdoor/heat source unit		Connectable outdoor/heat source unit capacity						
			P200/P400/M200/ M400	P450/M250/M300/ M450/M500	M350	P250/P300/P500	P350		
	High press. Pipe	mm (in.) O.D.	15.88 (5/8) Braze	15.88 (5/8) Braze	15.88 (5/8) Braze	19.05 (3/4) Braze	19.05 (3/4) Braze		
	Low press. Pipe	mm (in.) O.D.	19.05 (3/4) Braze	22.2 (7/8) Braze	28.58 (1-1/8) Braze	22.2 (7/8) Braze	28.58 (1-1/8) Braze		
To Main-HBC controller		mm (in.) O.D.	15.88 (5/8) Braze						
Water piping diameter									
Connection size	To Sub-HBC controller	Inlet/Outlet	mm O.D. 22						
	To Indoor unit	Inlet/Outlet	mm O.D. 22						
Field pipe size	To Sub-HBC controller	Total down-steam indoor unit capacity	W/WP/WL 10-100	W/WP/WL 101-200	W/WP/WL 201-300	W/WP/WL 301-400	W/WP/WL 401-500	W/WP/WL 501-525	
		Inlet/Outlet	mm I.D. (Min) 20.0	25.8	30.0	33.3	36.2	36.8	
	To Indoor unit	Total down-steam indoor unit capacity	W/WP/WL10-50				W/WP/WL51-125		
		Inlet/Outlet	mm I.D. (Min) 20					30	
Field drain pipe size		mm (in.)	O.D. 32 (1-1/4)						
Net weight		kg (lbs)	86 (190) [96 (212) with water]						
Standard attachment	Document								
	Accessories	Drain Connection pipe (with flexible hose and insulation), Tie band, Hose band, Wrench							
Optional parts									

- Notes:
- Installation/foundation work, electrical connection work, duct work, insulation work, power source switch, and other items shall be referred to the Installation Manual.
 - This unit is for R410A or R32 refrigerant.
 - Install this unit in a location where noise (refrigerant noise) emitted by the unit will not disturb the neighbors.
(For use in quiet environments with low background noise, position the HBC controller at least 5 m away from any indoor units.)
 - Please install the HBC controller in a place where noise will not be an issue.
 - Please attach an expansion vessel (field supply).
 - Please use copper or plastic pipes for the water circuit. Do not use steel or stainless steel pipework.
Furthermore, when using copper pipe-work use a non-oxidative brazing method.
Oxidation of the pipe-work will reduce the pump life.
 - When brazing the pipes, be sure to braze, after covering a wet cloth to the insulation pipes of the units in order to prevent it from burning and shrinking by heat.
 - Please install an air purge valve where air will gather in the water circuit.
 - Please install a pressure reducing valve and a strainer on the water supply to the HBC controller.
 - Please refer to the DATA BOOK or the Installation Manual for the specified water quality.
 - This unit is not designed for outside installations.
 - Please always make water circulate or pull out the circulation water completely when not using it.
*Please do not use it as a drinking water.
 - Please do not use ground water and well water.
 - The unit cannot be used when the outdoor temperature is outside the guaranteed operation range.
If the unit is used in such condition, the unit may not go into the Thermo-ON mode.
Guaranteed operation range: -5 to 52°C in cooling mode, -20 to 15.5°C in heating mode.
 - This product is not designed for preservation of food, animals, plants, precision equipment, or art objects.
To prevent quality loss, do not use the product for purposes other than what it is designed for.
 - The ambient relative humidity of the HBC controller needs to be kept below 80%.
 - Sound pressure level differs depending on the connected outdoor/heat source unit capacity or operation condition.
 - The sound pressure level values were obtained in an anechoic room. Actual sound pressure level is usually greater than that measured in anechoic room due to ambient noise and deflection sound.
 - Indoor unit capacity connectable to 1 branch is changed depending on the indoor unit type and connection method.
Please refer to the Installation Manual for more information.
 - R32 is flammable, and certain restrictions apply to the installation of units.
When installing new units, moving the existing units, or changing the layout of the room, ensure that installation restrictions are observed.
For detail, refer to the section in the DATA BOOK on installation restrictions.
 - The sound pressure level measured by the conventional method in JIS for reference purpose.
 - When installing the HBC controller in an environment which may drop below 0°C, please add antifreeze liquid to the circulating water. (Refer to the DATA BOOK and the Installation Manual).
 - For the refrigerant pipe size, refer to Installation Manual of outdoor units/heat source units.

1. SPECIFICATIONS

Model			CMB-WM1016V-AA						
Number of branch			16						
Power source			1-phase 220-230-240 V						
			50 Hz			60 Hz			
Power input (220-230-240)	Cooling	kW	0.45-0.46-0.47			0.45-0.46-0.47			
	Heating	kW	0.45-0.46-0.47			0.45-0.46-0.47			
Current input (220-230-240)	Cooling	A	2.89-2.83-2.79			2.89-2.83-2.79			
	Heating	A	2.89-2.83-2.79			2.89-2.83-2.79			
Sound pressure level (measured in anechoic room) *21			dB <A> 41						
Applicable temperature range of installation site *22			°C (D.B.) 0 to 32						
External finish			Galvanized steel plate (Drain pan: Pre-coated galvanized sheets + powder coating)						
Connectable outdoor/heat source unit model			PURY- (E)P200~500YNW-A/A1/A2 (-BS) PURY- (E)M200~500YNW-A/A1 (-BS) PURY- (E)P200~500YLM-A1 (-BS),PQRY-P200~500YLM-A1/A2						
Indoor unit capacity connectable to 1 branch			Model WP/W/L80 or smaller (Use optional joint pipe combining 2 branches when the total unit capacity exceeds WP/W/L81.)						
External dimension H × W × D		mm	300 x 1,800 x 630						
		in.	11-13/16 x 70-7/8 x 24-13/16						
Refrigerant *23 piping diameter	To outdoor/heat source unit		Connectable outdoor/heat source unit capacity						
			P200/P400/M200/ M400	P450/M250/M300/ M450/M500	M350	P250/P300/P500	P350		
	High press. Pipe	mm (in.) O.D.	15.88 (5/8) Braze	15.88 (5/8) Braze	15.88 (5/8) Braze	19.05 (3/4) Braze	19.05 (3/4) Braze		
	Low press. Pipe	mm (in.) O.D.	19.05 (3/4) Braze	22.2 (7/8) Braze	28.58 (1-1/8) Braze	22.2 (7/8) Braze	28.58 (1-1/8) Braze		
To Main-HBC controller		mm (in.) O.D.	15.88 (5/8) Braze						
Water piping diameter									
Connection size	To Sub-HBC controller	Inlet/Outlet	mm O.D. 22						
	To Indoor unit	Inlet/Outlet	mm O.D. 22						
Field pipe size	To Sub-HBC controller	Total down-steam indoor unit capacity	W/WP/WL 10-100	W/WP/WL 101-200	W/WP/WL 201-300	W/WP/WL 301-400	W/WP/WL 401-500	W/WP/WL 501-525	
		Inlet/Outlet	mm I.D. (Min)	20.0	25.8	30.0	33.3	36.2	36.8
	To Indoor unit	Total down-steam indoor unit capacity	W/WP/WL10-50			W/WP/WL51-125			
		Inlet/Outlet	mm I.D. (Min)			20			30
Field drain pipe size		mm (in.)	O.D. 32 (1-1/4)						
Net weight		kg (lbs)	98 (217) [111 (245) with water]						
Standard attachment	Document								
	Accessories	Drain Connection pipe (with flexible hose and insulation), Tie band, Hose band, Wrench							
Optional parts									

- Notes:
- Installation/foundation work, electrical connection work, duct work, insulation work, power source switch, and other items shall be referred to the Installation Manual.
 - This unit is for R410A or R32 refrigerant.
 - Install this unit in a location where noise (refrigerant noise) emitted by the unit will not disturb the neighbors.
(For use in quiet environments with low background noise, position the HBC controller at least 5 m away from any indoor units.)
 - Please install the HBC controller in a place where noise will not be an issue.
 - Please attach an expansion vessel (field supply).
 - Please use copper or plastic pipes for the water circuit. Do not use steel or stainless steel pipework.
Furthermore, when using copper pipe-work use a non-oxidative brazing method.
Oxidation of the pipe-work will reduce the pump life.
 - When brazing the pipes, be sure to braze, after covering a wet cloth to the insulation pipes of the units in order to prevent it from burning and shrinking by heat.
 - Please install an air purge valve where air will gather in the water circuit.
 - Please install a pressure reducing valve and a strainer on the water supply to the HBC controller.
 - Please refer to the DATA BOOK or the Installation Manual for the specified water quality.
 - This unit is not designed for outside installations.
 - Please always make water circulate or pull out the circulation water completely when not using it.
*Please do not use it as a drinking water.
 - Please do not use ground water and well water.
 - The unit cannot be used when the outdoor temperature is outside the guaranteed operation range.
If the unit is used in such condition, the unit may not go into the Thermo-ON mode.
Guaranteed operation range: -5 to 52°C in cooling mode, -20 to 15.5°C in heating mode.
 - This product is not designed for preservation of food, animals, plants, precision equipment, or art objects.
To prevent quality loss, do not use the product for purposes other than what it is designed for.
 - The ambient relative humidity of the HBC controller needs to be kept below 80%.
 - Sound pressure level differs depending on the connected outdoor/heat source unit capacity or operation condition.
 - The sound pressure level values were obtained in an anechoic room. Actual sound pressure level is usually greater than that measured in anechoic room due to ambient noise and deflection sound.
 - Indoor unit capacity connectable to 1 branch is changed depending on the indoor unit type and connection method.
Please refer to the Installation Manual for more information.
 - R32 is flammable, and certain restrictions apply to the installation of units.
When installing new units, moving the existing units, or changing the layout of the room, ensure that installation restrictions are observed.
For detail, refer to the section in the DATA BOOK on installation restrictions.
 - The sound pressure level measured by the conventional method in JIS for reference purpose.
 - When installing the HBC controller in an environment which may drop below 0°C, please add antifreeze liquid to the circulating water. (Refer to the DATA BOOK and the Installation Manual).
 - For the refrigerant pipe size, refer to Installation Manual of outdoor units/heat source units.

1. SPECIFICATIONS

HBC controller

HBC controller

Model				CMB-WM350F-AA			
Number of branch				6			
Power source				1-phase 220-230-240 V			
				50 Hz		60 Hz	
Power input (220-230-240)	Cooling	kW	1.50-1.50-1.50		1.50-1.50-1.50		
	Heating	kW	1.50-1.50-1.50		1.50-1.50-1.50		
Current input (220-230-240)	Cooling	A	6.82-6.52-6.25		6.82-6.52-6.25		
	Heating	A	6.82-6.52-6.25		6.82-6.52-6.25		
Sound pressure level (measured in anechoic room)				dB <A> 54			
Applicable temperature range of installation site				°C (D.B.) 0~40			
External finish				Galvanized steel plate			
Connectable outdoor/heat source unit capacity				PURY-M200~350YNW-A1 (-BS)/PURY-EM200~350YNW-A1 (-BS)			
Indoor unit capacity connectable to 1 branch				Model WP/W/WL80 or smaller (Use optional joint pipe combining 2 branches when the total unit capacity exceeds WP/W/WL80.)			
External dimension H x W x D			mm	1,500 x 800 x 500			
			in.	59-1/16 x 31-1/2 x 19-11/16			
Refrigerant piping diameter	To outdoor/heat source unit		Connectable outdoor/heat source unit capacity				
			M200	M250/M300	M350		
	High press. Pipe	mm (in.) O.D.	15.88 (5/8)	15.88 (5/8)	15.88 (5/8)		
			Brazed	Brazed	Brazed		
Low press. Pipe	mm (in.) O.D.	19.05 (3/4)	22.2 (7/8)	28.58 (1-1/8)			
		Brazed	Brazed	Brazed			
Water piping diameter							
Connection size	To Sub-HBC	Inlet/Outlet	mm O.D.	42			
	To Indoor unit	Inlet/Outlet	mm O.D.	22			
Field pipe size	Inlet/Outlet	mm I.D. (Min)	Total down-stream Indoor unit capacity	Piping length from Main-HBC to farthest Indoor unit			
				Max 20m	Max 40m	Max 60m	
			W/WP/WL10	12	12	12	
			W/WP/WL11-15	12	12	15.5	
			W/WP/WL16-25	15.5	15.5	15.5	
			W/WP/WL26-32	15.5	19.9	19.9	
			W/WP/WL33-50	19.9	19.9	19.9	
			W/WP/WL51-63	19.9	25.2	25.2	
			W/WP/WL64-80	25.2	25.2	25.2	
			W/WP/WL81-100	25.2	25.2	32.6	
			W/WP/WL101-150	32.6	32.6	32.6	
			W/WP/WL151-250	32.6	32.6	39.6	
W/WP/WL251-300	32.6	39.6	50.8				
W/WP/WL301-750	50.8	50.8	50.8				
Field drain pipe size			mm (in.)	O.D. 26.7 (1-1/16)			
Net weight			kg (lbs)	196 (433) [216 (477) with water]			
Standard attachment	Document						
	Accessories						
Optional parts							

- Notes:
- 1.Installation/foundation work, electrical connection work, duct work, insulation work, power source switch, and other items shall be referred to the Installation Manual.
 - 2.This unit is for R32 refrigerant.
 - 3.Install this unit in a location where noise (refrigerant noise) emitted by the unit will not disturb the neighbors.
(For use in quiet environments with low background noise, position the HBC at least 5 m away from any indoor units.)
 - 4.Please install the HBC in a place where noise will not be an issue.
 - 5.Please attach an expansion vessel (field supply).
 - 6.Please use copper or plastic pipes for the water circuit. Do not use steel or stainless steel pipework.
Furthermore, when using copper pipe-work use a non-oxidative brazing method.
Oxidation of the pipe-work will reduce the pump life.
 - 7.When brazing the pipes, be sure to braze, after covering a wet cloth to the insulation pipes of the units in order to prevent it from burning and shrinking by heat.
 - 8.Please install an air purge valve where air will gather in the water circuit.
 - 9.Please install a pressure reducing valve and a strainer on the water supply to the HBC.
 - 10.Please refer to the DATA BOOK or the Installation Manual for the specified water quality.
 - 11.This unit is not designed for outside installations.
 - 12.Please always make water circulate or pull out the circulation water completely when not using it.
*Please do not use it as a drinking water.
 - 13.Please do not use ground water and well water.
 - 14.When installing the HBC in an environment which may drop below 0°C, please add antifreeze liquid to the circulating water. (Refer to the DATA BOOK and the Installation Manual).
 - 15.R32 is flammable, and certain restrictions apply to the installation of units.
When installing new units, moving the existing units, or changing the layout of the room, ensure that installation restrictions are observed.
For detail, refer to the section in the DATA BOOK on installation restrictions.

1. SPECIFICATIONS

Model				CMB-WM500F-AA			
Number of branch				6			
Power source				1-phase 220-230-240 V			
				50 Hz		60 Hz	
Power input (220-230-240)	Cooling	kW	1.50-1.50-1.50		1.50-1.50-1.50		
	Heating	kW	1.50-1.50-1.50		1.50-1.50-1.50		
Current input (220-230-240)	Cooling	A	6.82-6.52-6.25		6.82-6.52-6.25		
	Heating	A	6.82-6.52-6.25		6.82-6.52-6.25		
Sound pressure level (measured in anechoic room)			dB <A>		54		
Applicable temperature range of installation site			°C (D.B.)		0~40		
External finish				Galvanized steel plate			
Connectable outdoor/heat source unit capacity				PURY-M400~500YNW-A1 (-BS)/PURY-EM400~500YNW-A1 (-BS)			
Indoor unit capacity connectable to 1 branch				Model WP/W/WL80 or smaller (Use optional joint pipe combining 2 branches when the total unit capacity exceeds WP/W/WL80.)			
External dimension H x W x D			mm	1,500 x 800 x 500			
			in.	59-1/16 x 31-1/2 x 19-11/16			
Refrigerant piping diameter	To outdoor/heat source unit		Connectable outdoor/heat source unit capacity				
			M400/M450/M500				
	High press. Pipe	mm (in.) O.D.	19.05 (3/4) Braze				
Low press. Pipe	mm (in.) O.D.	28.58 (1-1/8) Braze					
Water piping diameter							
Connection size	To Sub-HBC	Inlet/Outlet	mm O.D.	42			
	To Indoor unit	Inlet/Outlet	mm O.D.	22			
Field pipe size		Inlet/Outlet	mm I.D. (Min)	Total down-stream Indoor unit capacity	Piping length from Main-HBC to farthest Indoor unit		
					Max 20m	Max 40m	Max 60m
				W/WP/WL10	12	12	12
				W/WP/WL11-15	12	12	15.5
				W/WP/WL16-25	15.5	15.5	15.5
				W/WP/WL26-32	15.5	19.9	19.9
				W/WP/WL33-50	19.9	19.9	19.9
				W/WP/WL51-63	19.9	25.2	25.2
				W/WP/WL64-80	25.2	25.2	25.2
				W/WP/WL81-100	25.2	25.2	32.6
				W/WP/WL101-150	32.6	32.6	32.6
				W/WP/WL151-250	32.6	32.6	39.6
				W/WP/WL251-300	32.6	39.6	50.8
				W/WP/WL301-750	50.8	50.8	50.8
Field drain pipe size			mm (in.)	O.D. 26.7 (1-1/16)			
Net weight			kg (lbs)	209 (461) [233 (514) with water]			
Standard attachment	Document			-			
	Accessories			-			
Optional parts				-			

- Notes:
- 1.Installation/foundation work, electrical connection work, duct work, insulation work, power source switch, and other items shall be referred to the Installation Manual.
 - 2.This unit is for R32 refrigerant.
 - 3.Install this unit in a location where noise (refrigerant noise) emitted by the unit will not disturb the neighbors. (For use in quiet environments with low background noise, position the HBC at least 5 m away from any indoor units.)
 - 4.Please install the HBC in a place where noise will not be an issue.
 - 5.Please attach an expansion vessel (field supply).
 - 6.Please use copper or plastic pipes for the water circuit. Do not use steel or stainless steel pipework. Furthermore, when using copper pipe-work use a non-oxidative brazing method. Oxidation of the pipe-work will reduce the pump life.
 - 7.When brazing the pipes, be sure to braze, after covering a wet cloth to the insulation pipes of the units in order to prevent it from burning and shrinking by heat.
 - 8.Please install an air purge valve where air will gather in the water circuit.
 - 9.Please install a pressure reducing valve and a strainer on the water supply to the HBC.
 - 10.Please refer to the DATA BOOK or the Installation Manual for the specified water quality.
 - 11.This unit is not designed for outside installations.
 - 12.Please always make water circulate or pull out the circulation water completely when not using it. *Please do not use it as a drinking water.
 - 13.Please do not use ground water and well water.
 - 14.When installing the HBC in an environment which may drop below 0°C, please add antifreeze liquid to the circulating water. (Refer to the DATA BOOK and the Installation Manual).
 - 15.R32 is flammable, and certain restrictions apply to the installation of units. When installing new units, moving the existing units, or changing the layout of the room, ensure that installation restrictions are observed. For detail, refer to the section in the DATA BOOK on installation restrictions.

1. SPECIFICATIONS

HBC controller

HBC controller

Model		CMB-WM108V-BB								
Number of branch		8								
Power source		1-phase 220-230-240 V								
		50 Hz				60 Hz				
Power input (220-230-240)	Cooling	kW	0.01-0.01-0.01				0.01-0.01-0.01			
	Heating	kW	0.01-0.01-0.01				0.01-0.01-0.01			
Current input (220-230-240)	Cooling	A	0.14-0.14-0.14				0.14-0.14-0.14			
	Heating	A	0.14-0.14-0.14				0.14-0.14-0.14			
Sound pressure level (measured in anechoic room)		dB <A>		-						
Applicable temperature range of installation site *18		°C (D.B.)		0 to 32						
External finish		Galvanized steel plate								
Connectable outdoor/heat source unit model		-								
Indoor unit capacity connectable to 1 branch		Model WP/W/L80 or smaller (Use optional joint pipe combining 2 branches when the total unit capacity exceeds WP/W/L81.)								
External dimension H x W x D		mm		310 x 930 x 630						
		in.		12-1/4 x 36-5/8 x 24-13/16						
Water piping diameter (Horizontal type HBC connection)										
Connection size	To Main-HBC controller	Inlet/Outlet	mm O.D.							
	To Indoor unit	Inlet/Outlet	mm O.D.							
Field pipe size	To Main-HBC controller	Total down-steam indoor unit capacity	W/WP/WL 10-100	W/WP/WL 101-200	W/WP/WL 201-300	W/WP/WL 301-400	W/WP/WL 401-500	W/WP/WL 501-525		
		Inlet/Outlet	mm I.D. (Min)	20.0	25.8	30.0	33.3	36.2	36.8	
	To Indoor unit	Total down-steam indoor unit capacity	W/WP/WL10-50				W/WP/WL51-125			
		Inlet/Outlet	mm I.D. (Min)	20				30		
Water piping diameter (Vertical type HBC connection)										
Connection size	To Main-HBC controller	Inlet/Outlet	mm O.D.							
	To Indoor unit	Inlet/Outlet	mm O.D.							
Field pipe size	Inlet/Outlet	mm I.D. (Min)	Total down-steam Indoor unit capacity	Piping length from Main-HBC to farthest Indoor unit						
				Max 20m	Max 40m	Max 60m				
			W/WP/WL10	12	12	12				
			W/WP/WL11-15	12	12	15.5				
			W/WP/WL16-25	15.5	15.5	15.5				
			W/WP/WL26-32	15.5	19.9	19.9				
			W/WP/WL33-50	19.9	19.9	19.9				
			W/WP/WL51-63	19.9	25.2	25.2				
			W/WP/WL64-80	25.2	25.2	25.2				
			W/WP/WL81-100	25.2	25.2	32.6				
			W/WP/WL101-150	32.6	32.6	32.6				
			W/WP/WL151-250	32.6	32.6	39.6				
			W/WP/WL251-300	32.6	39.6	50.8				
W/WP/WL301-750	50.8	50.8	50.8							
Field drain pipe size		mm (in.)		O.D. 32 (1-1/4)						
Net weight		kg (lbs)		40 (89) [45 (100) with water]						
Standard attachment	Document	-								
	Accessories	Drain Connection pipe, Washer, Tie band								
Optional parts		-								

- Notes:
- 1.Installation/foundation work, electrical connection work, duct work, insulation work, power source switch, and other items shall be referred to the Installation Manual.
 - 2.This unit is for water.
 - 3.Install this unit in a location where noise (refrigerant noise) emitted by the unit will not disturb the neighbors.
(For use in quiet environments with low background noise, position the Sub-HBC controller at least 5 m away from any indoor units.)
 - 4.Please install the Sub-HBC controller in a place where noise will not be an issue.
 - 5.Please attach an expansion vessel (field supply).
 - 6.Please use copper or plastic pipes for the water circuit. Do not use steel or stainless steel pipework.
Furthermore, when using copper pipe-work use a non-oxidative brazing method.
Oxidation of the pipe-work will reduce the pump life.
 - 7.When brazing the pipes, be sure to braze, after covering a wet cloth to the insulation pipes of the units in order to prevent it from burning and shrinking by heat.
 - 8.Please install an air purge valve where air will gather in the water circuit.
 - 9.Please refer to the DATA BOOK or the Installation Manual for the specified water quality.
 - 10.This unit is not designed for outside installations.
 - 11.Please always make water circulate or pull out the circulation water completely when not using it.
*Please do not use it as a drinking water.
 - 12.Please do not use ground water and well water.
 - 13.Can't use singleness. (Main-HBC controller is necessary)
 - 14.The unit cannot be used when the outdoor temperature is outside the guaranteed operation range.
If the unit is used in such condition, the unit may not go into the Thermo-ON mode.
Guaranteed operation range: -5 to 52°C in cooling mode, -20 to 15.5°C in heating mode.
 - 15.This product is not designed for preservation of food, animals, plants, precision equipment, or art objects.
To prevent quality loss, do not use the product for purposes other than what it is designed for.
 - 16.The ambient relative humidity of the HBC controller needs to be kept below 80%.
 - 17.Indoor unit capacity connectable to 1 branch is changed depending on the indoor unit type and connection method.
Please refer to the Installation Manual for more information.
 - 18.When installing the HBC controller in an environment which may drop below 0°C, please add antifreeze liquid to the circulating water. (Refer to the DATA BOOK and the Installation Manual).

1. SPECIFICATIONS

Model				CMB-WM1016V-BB					
Number of branch				16					
Power source				1-phase 220-230-240 V					
				50 Hz			60 Hz		
Power input (220-230-240)	Cooling	kW	0.01-0.01-0.01			0.01-0.01-0.01			
	Heating	kW	0.01-0.01-0.01			0.01-0.01-0.01			
Current input (220-230-240)	Cooling	A	0.14-0.14-0.14			0.14-0.14-0.14			
	Heating	A	0.14-0.14-0.14			0.14-0.14-0.14			
Sound pressure level (measured in anechoic room)				dB <A>					
Applicable temperature range of installation site *18				°C (D.B.)					
External finish				Galvanized steel plate					
Connectable outdoor/heat source unit model				-					
Indoor unit capacity connectable to 1 branch				Model WP/W/WL80 or smaller (Use optional joint pipe combining 2 branches when the total unit capacity exceeds WP/W/WL81.)					
External dimension H x W x D		mm		310 x 1,210 x 630					
		in.		12-1/4 x 47-11/16 x 24-13/16					
Water piping diameter (Horizontal type HBC connection)									
Connection size	To Main-HBC controller	Inlet/Outlet	mm O.D.						
	To Indoor unit	Inlet/Outlet	mm O.D.						
Field pipe size	To Main-HBC controller	Total down-steam indoor unit capacity	W/WP/WL 10-100	W/WP/WL 101-200	W/WP/WL 201-300	W/WP/WL 301-400	W/WP/WL 401-500	W/WP/WL 501-525	
		Inlet/Outlet	mm I.D. (Min)	20.0	25.8	30.0	33.3	36.2	36.8
	To Indoor unit	Total down-steam indoor unit capacity	W/WP/WL 10-50			W/WP/WL 51-125			
		Inlet/Outlet	mm I.D. (Min)	20			30		
Water piping diameter (Vertical type HBC connection)									
Connection size	To Main-HBC controller	Inlet/Outlet	mm O.D.						
	To Indoor unit	Inlet/Outlet	mm O.D.						
Field pipe size	Inlet/Outlet	mm I.D. (Min)	Total down-steam indoor unit capacity	Piping length from Main-HBC to farthest Indoor unit					
				Max 20m	Max 40m	Max 60m			
			W/WP/WL10	12	12	12			
			W/WP/WL11-15	12	12	15.5			
			W/WP/WL16-25	15.5	15.5	15.5			
			W/WP/WL26-32	15.5	19.9	19.9			
			W/WP/WL33-50	19.9	19.9	19.9			
			W/WP/WL51-63	19.9	25.2	25.2			
			W/WP/WL64-80	25.2	25.2	25.2			
			W/WP/WL81-100	25.2	25.2	32.6			
			W/WP/WL101-150	32.6	32.6	32.6			
			W/WP/WL151-250	32.6	32.6	39.6			
			W/WP/WL251-300	32.6	39.6	50.8			
W/WP/WL301-750	50.8	50.8	50.8						
Field drain pipe size		mm (in.)		O.D. 32 (1-1/4)					
Net weight		kg (lbs)		53 (117) [62 (137) with water]					
Standard attachment	Document	-							
	Accessories	Drain Connection pipe, Washer, Tie band							
Optional parts				-					

- Notes:
- Installation/foundation work, electrical connection work, duct work, insulation work, power source switch, and other items shall be referred to the Installation Manual.
 - This unit is for water.
 - Install this unit in a location where noise (refrigerant noise) emitted by the unit will not disturb the neighbors.
(For use in quiet environments with low background noise, position the Sub-HBC controller at least 5 m away from any indoor units.)
 - Please install the Sub-HBC controller in a place where noise will not be an issue.
 - Please attach an expansion vessel (field supply).
 - Please use copper or plastic pipes for the water circuit. Do not use steel or stainless steel pipework.
Furthermore, when using copper pipe-work use a non-oxidative brazing method.
Oxidation of the pipe-work will reduce the pump life.
 - When brazing the pipes, be sure to braze, after covering a wet cloth to the insulation pipes of the units in order to prevent it from burning and shrinking by heat.
 - Please install an air purge valve where air will gather in the water circuit.
 - Please refer to the DATA BOOK or the Installation Manual for the specified water quality.
 - This unit is not designed for outside installations.
 - Please always make water circulate or pull out the circulation water completely when not using it.
*Please do not use it as a drinking water.
 - Please do not use ground water and well water.
 - Can't use singleness. (Main-HBC controller is necessary)
 - The unit cannot be used when the outdoor temperature is outside the guaranteed operation range.
If the unit is used in such condition, the unit may not go into the Thermo-ON mode.
Guaranteed operation range: -5 to 52°C in cooling mode, -20 to 15.5°C in heating mode.
 - This product is not designed for preservation of food, animals, plants, precision equipment, or art objects.
To prevent quality loss, do not use the product for purposes other than what it is designed for.
 - The ambient relative humidity of the HBC controller needs to be kept below 80%.
 - Indoor unit capacity connectable to 1 branch is changed depending on the indoor unit type and connection method.
Please refer to the Installation Manual for more information.
 - When installing the HBC controller in an environment which may drop below 0°C, please add antifreeze liquid to the circulating water. (Refer to the DATA BOOK and the Installation Manual).

CMB-WM1016V-AA

Unit : mm

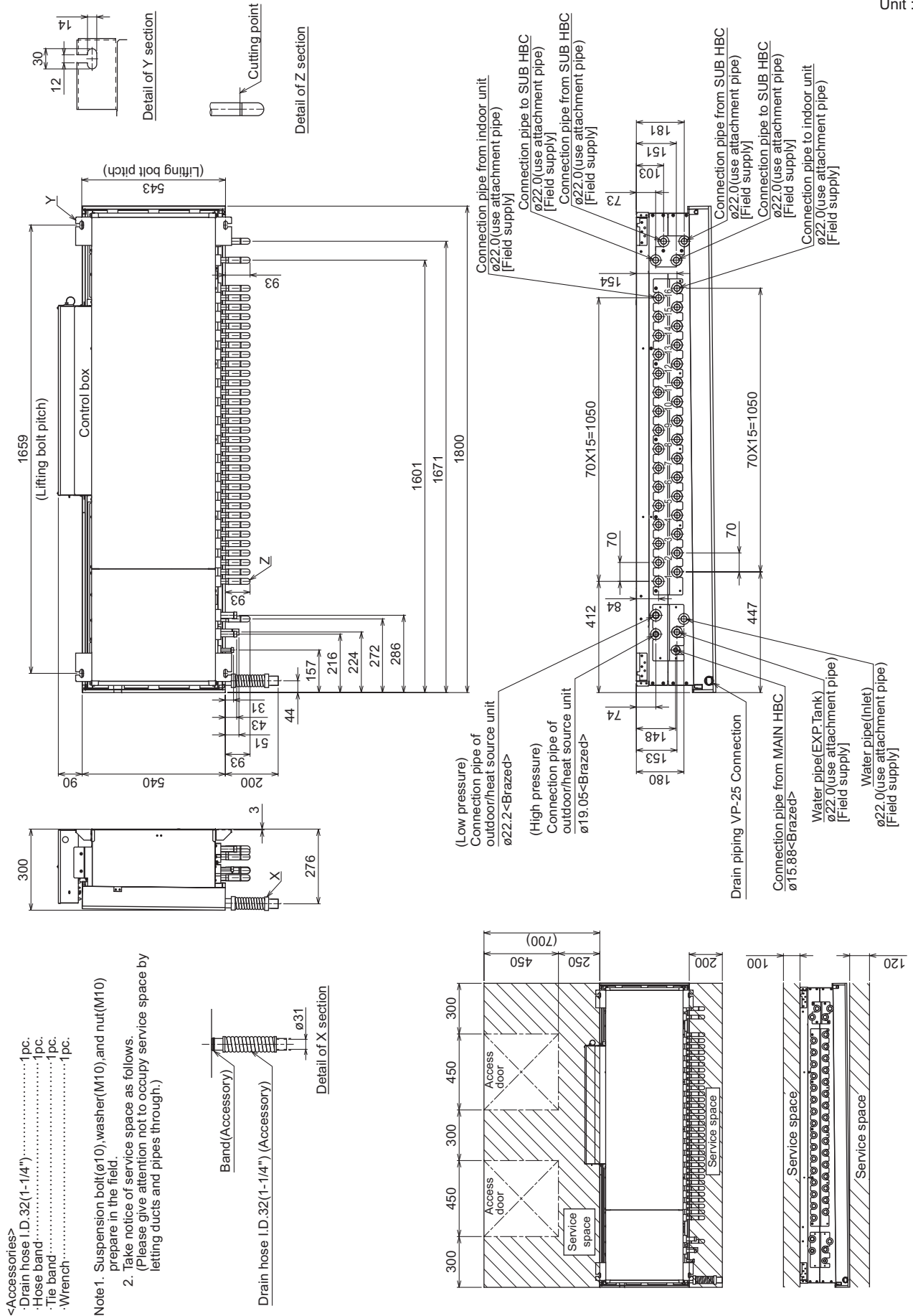

CMB-WM350, 500F-AA

Unit : mm

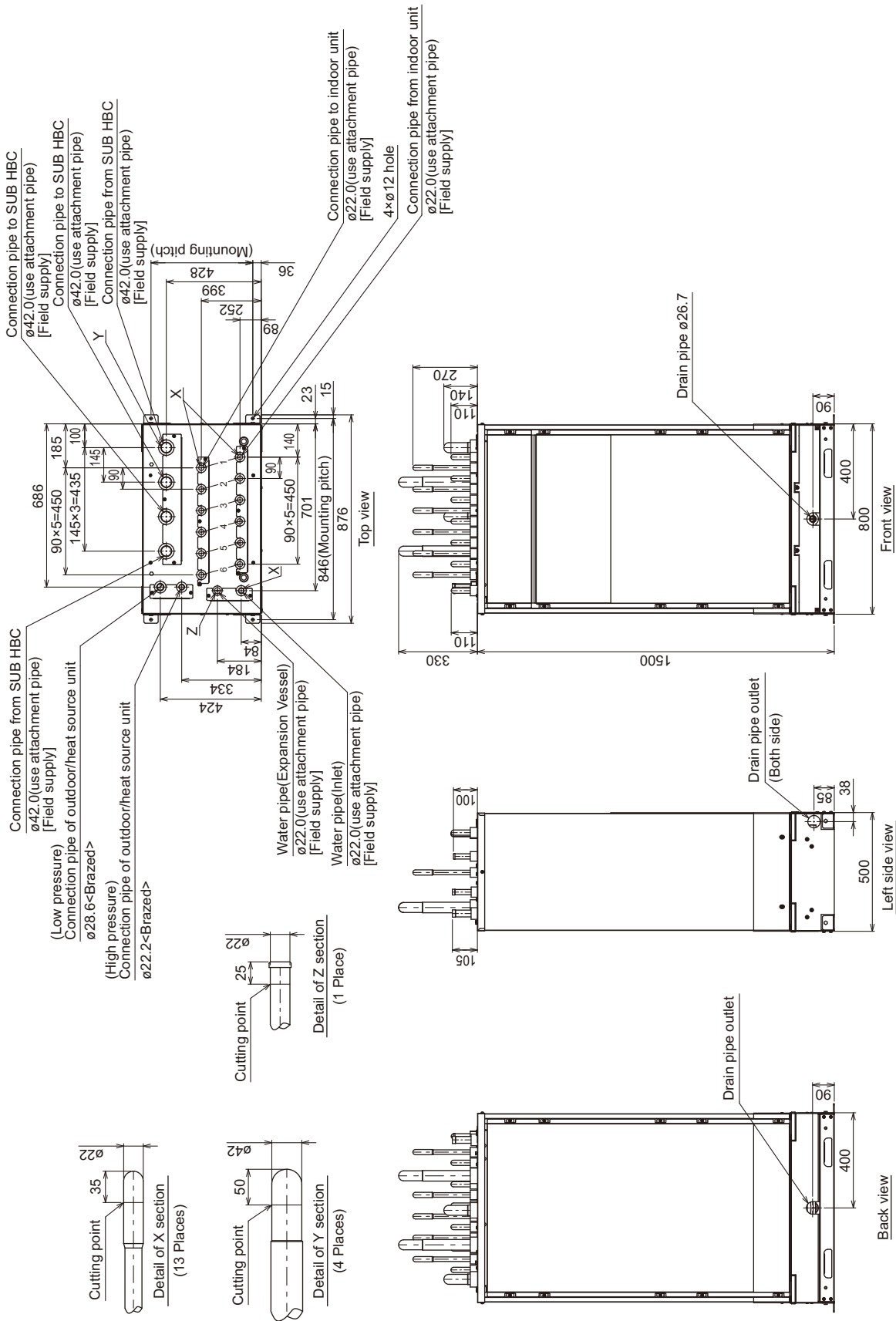

Unit : mm

- Note 1. Take notice of service space as Fig.A.
(Please give attention not to occupy service space by letting pipes through.)
2. By changing the direction of the drain pan, it is possible to connect the drain pipe from the back side.
In case of removing the drain pan after the unit is installed, please secure a service space of 150 mm to the left and right sides. Refer to the Installation Manual for changing the direction of the drain pan.
3. Maintenance is possible only from the front, however the serviceability can be improved by securing a service space of 450mm on the left, right and back side and removing the panels.
4. It is also possible to hold the unit as shown in Fig. B and Fig. C.
Refer to the Installation Manual for holding the unit.
5. Refer to the DATA BOOK about connection pipe and drain pipe diameter size.
6. Refer to the Installation Manual about the specification for connection pipe and drain pipe insulation.

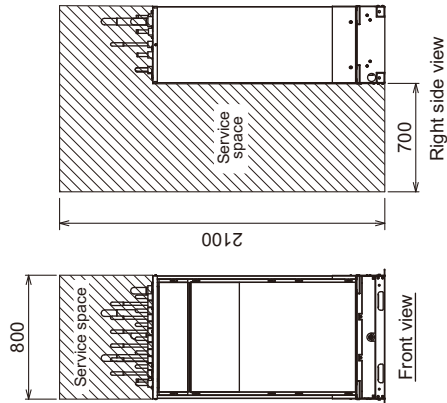
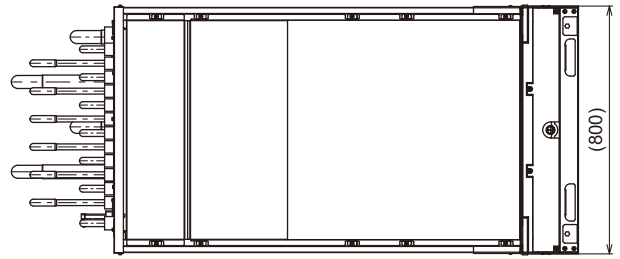
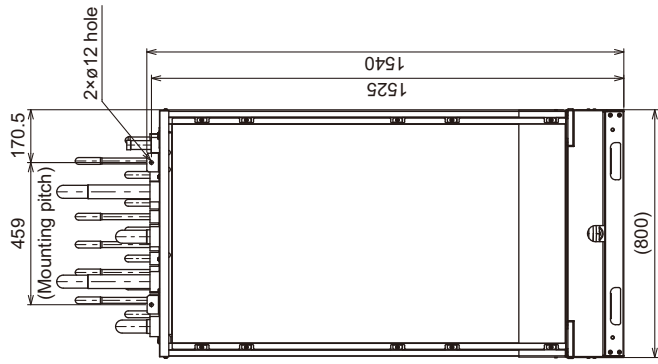
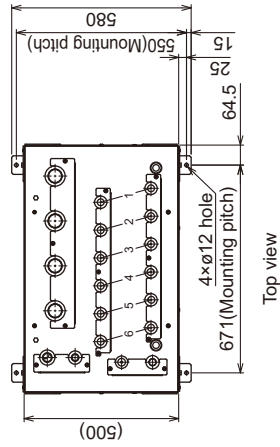
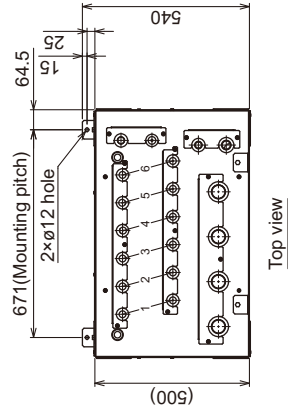

Fig.A

Fig.C

Fig.B

CMB-WM108V-BB

Unit : mm

- Note 1. Suspension bolt(φ10) and nut(M10) prepare in the field.
 2. Take notice of service space as shown.
 (Please give attention not to occupy service space by letting ducts and pipes through.)
 3. To remove the drain pan, the screws (5 points) on the front side and back side of the bottom have to be removed below the unit.

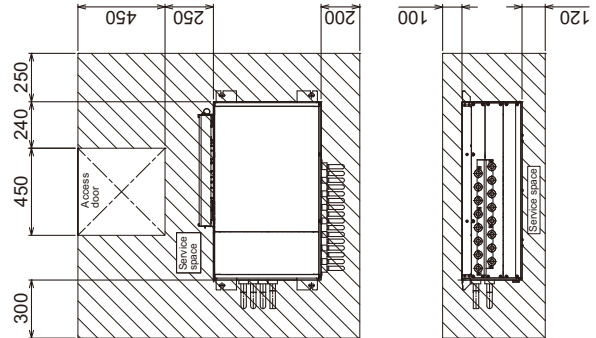
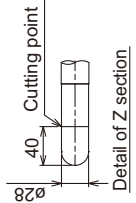
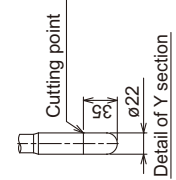
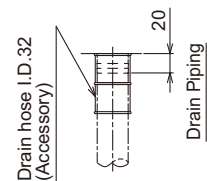
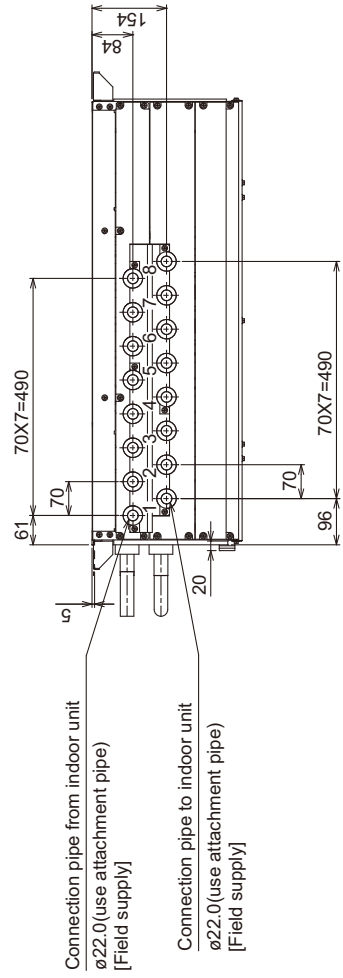
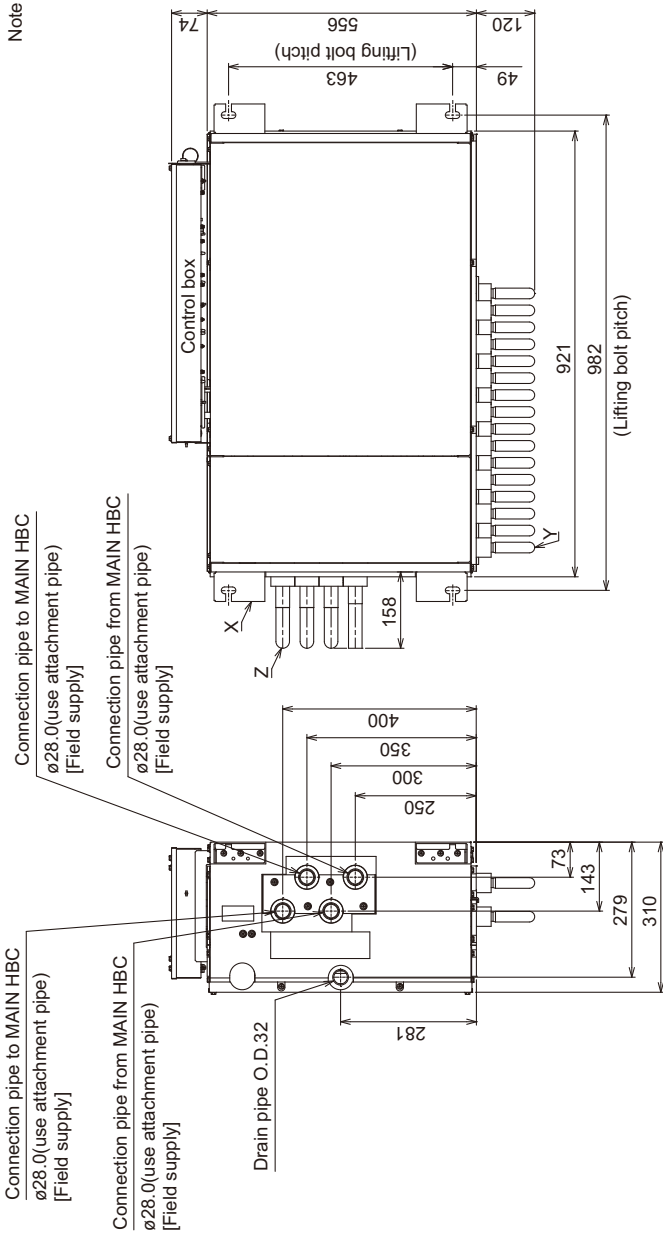

- <Accessories>
 · Drain hose I.D.321pc.
 · Tie band3pcs.
 · Square washer (with cushion)4pcs.
 · Square washer4pcs.

CMB-WM1016V-BB

Unit : mm

- Note 1. Suspension bolt(φ10) and nut(M10) prepare in the field.
 2. Take notice of service space as shown.
 (Please give attention not to occupy service space by letting ducts and pipes through.)
 3. To remove the drain pan, the screws (5 points) on the front side and back side of the bottom have to be removed below the unit.

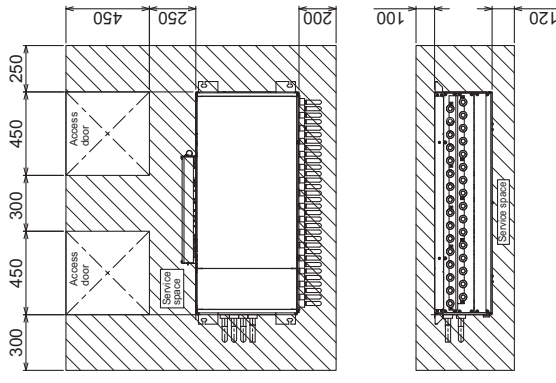
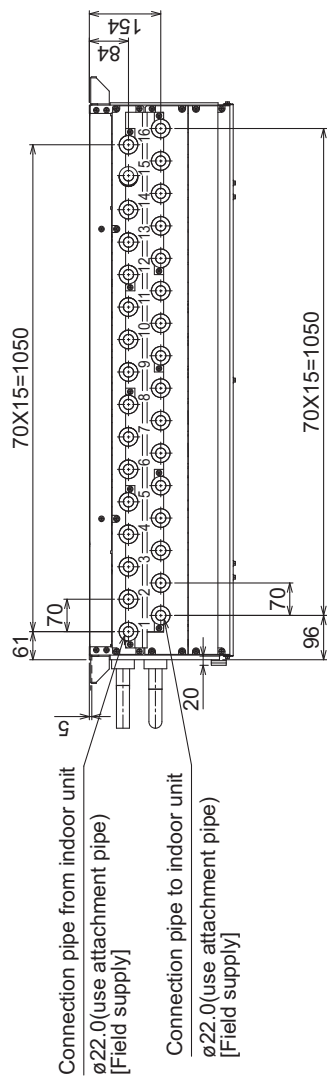
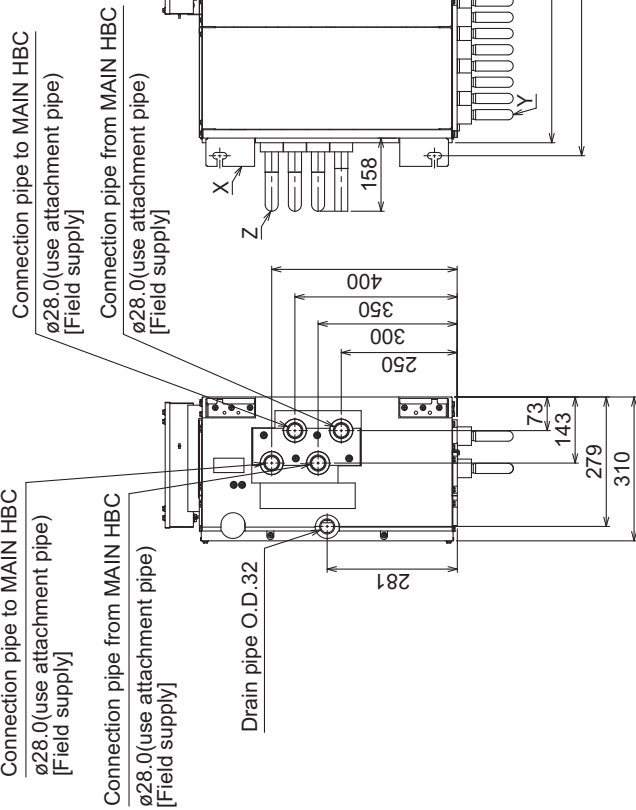

- <Accessories>
 · Drain hose I.D. 32.....1pc.
 · Tie band.....3pcs.
 · Square washer (with cushion).....4pcs.
 · Square washer.....4pcs.

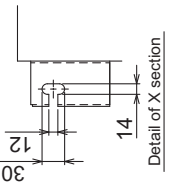
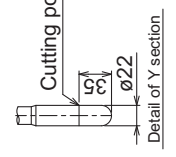
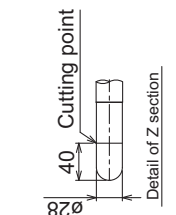

CMB-WM108, 1016V-AA

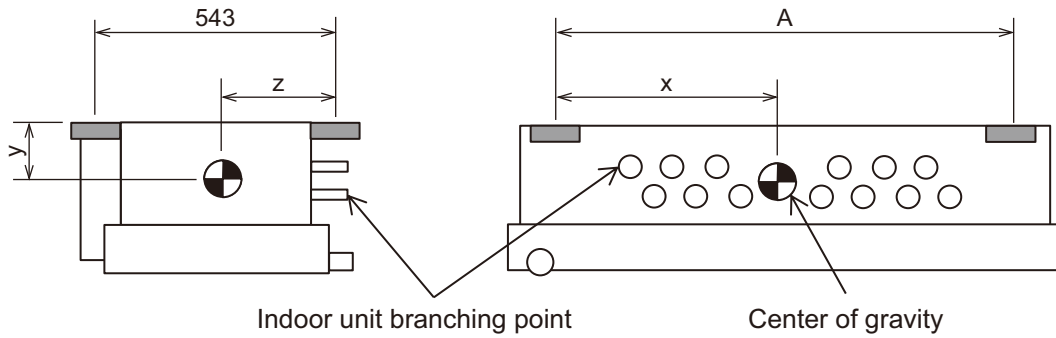

Indoor unit branching point

Center of gravity

	CMB-WM108V-AA	CMB-WM1016V-AA
A (mm)	1379	1659
x (mm)	680	825
y (mm)	145	145
z (mm)	285	285

CMB-WM350, 500F-AA

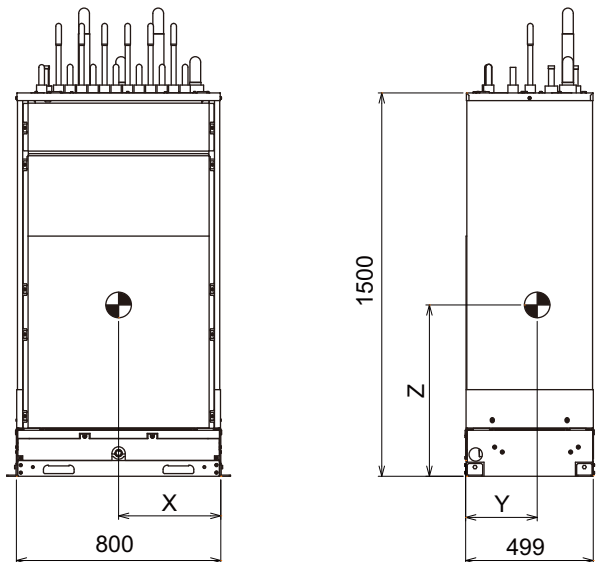

	CMB-WM350F-AA	CMB-WM500F-AA
x (mm)	400	400
y (mm)	270	280
z (mm)	650	670

CMB-WM108, 1016V-BB

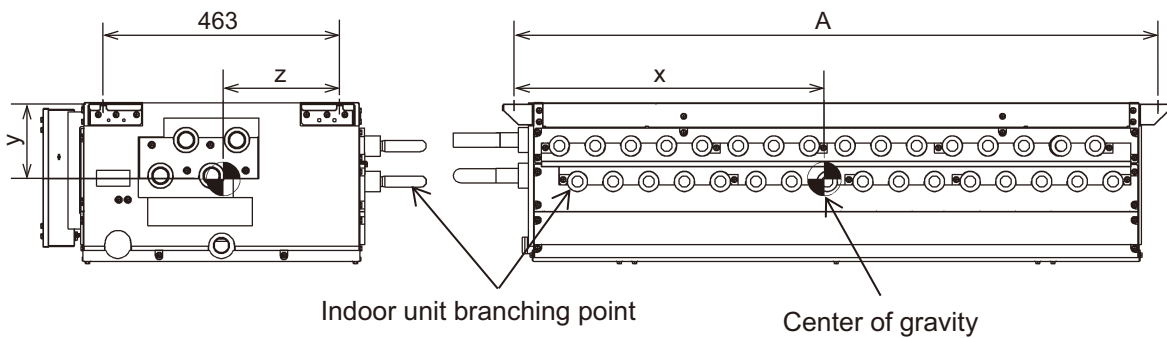

Indoor unit branching point

Center of gravity

	CMB-WM108V-BB	CMB-WM1016V-BB
A (mm)	982	1262
x (mm)	466	608
y (mm)	142	146
z (mm)	249	228

CMB-WM108V-AA

(Symbol explanation)	Symbol	Name	Symbol	Name
ACI	AC reactor	SV1	Solenoid valve	
TH1~16, TH32~35	Thermister sensor	F001	Fuse AC250V 6.3A F	
TH31a~h	Expansion valve	21S4Ma, 21S4Mb	4-way valve	
LEV1~3	Pressure sensor	WP1, WP2	Pump	
PS1, PS3	Terminal block	VB3a~h	Valve block	
TB01	Terminal block (for power source)	FS	Float switch	
TB02	Terminal block (for Transmission)	Z	Function setting connector	

NOTE:1. TB02 is transmission terminal block.
 Never connect power line to it.
 2. The initial set values of switch on Control Board are as follows.
 SW1:0
 SW2:0
 3. The wirings to TB01 and TB02 shown in dotted line are field work.

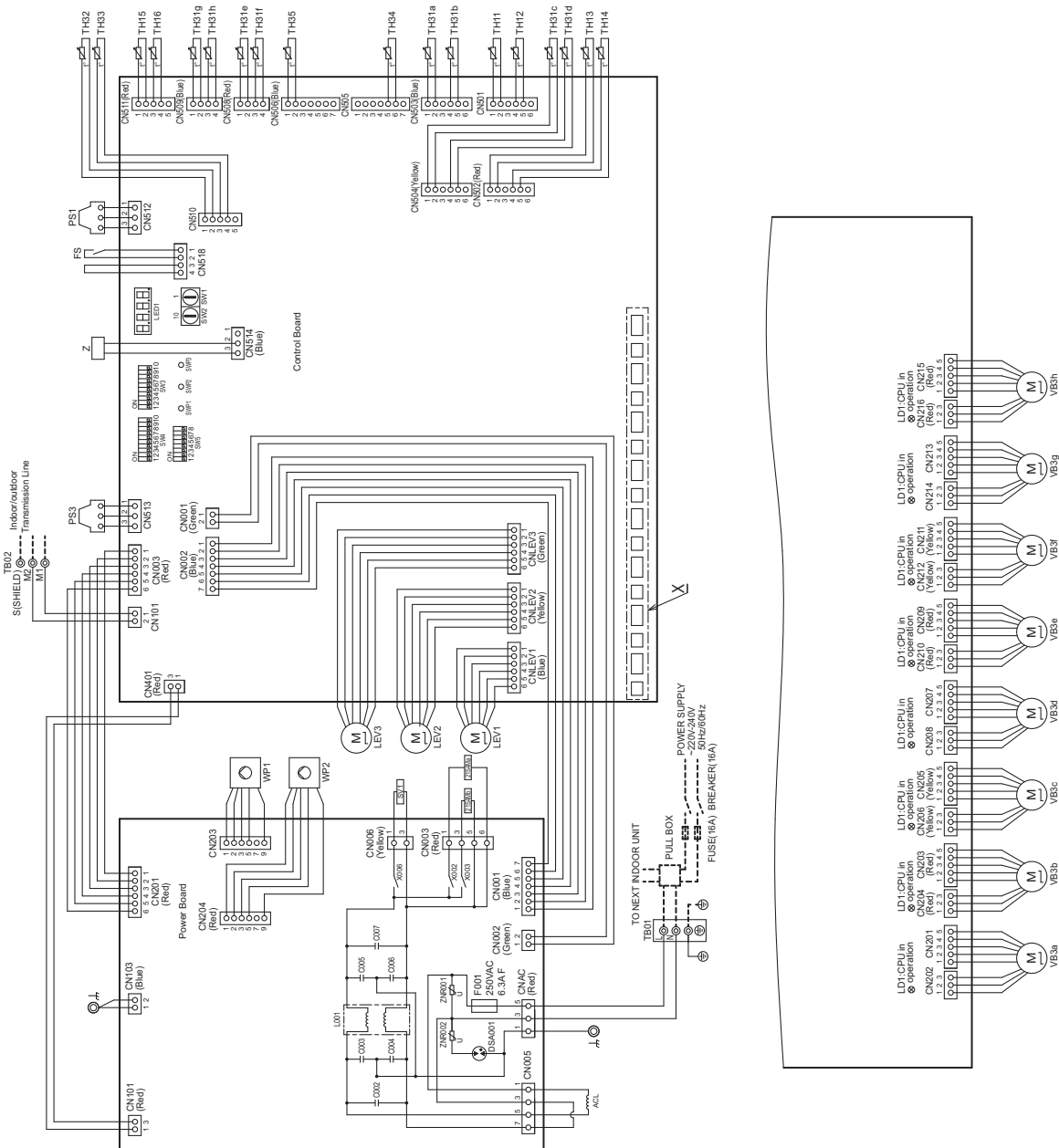

Detail of X section

CMB-WM1016V-AA

(Symbol explanation)			
Symbol	Name	Symbol	Name
ACL	AC reactor	SV1	Solenoid valve
TH11~16, TH2~35	Thermister sensor	F001	Fuse AC250V 6.3A F
TH3 ta-p	Expansion valve	WP1, WP2	4 way valve
LEV1~3	Pressure sensor	VP3a-p	Pump
PS1, PS3	Terminal block (for power source)	FS	Float switch
TB01	Terminal block (for transmission)	Z	Function setting connector
TB02	Terminal block (for transmission)		

- NOTE: 1. TB02 is transmission terminal block.
Never connect power line to it.
2. The initial set values of switch on Control Board are as follows.
SW1:0
SW2:0
3. The wirings to TB01 and TB02 shown in dotted line are field work.

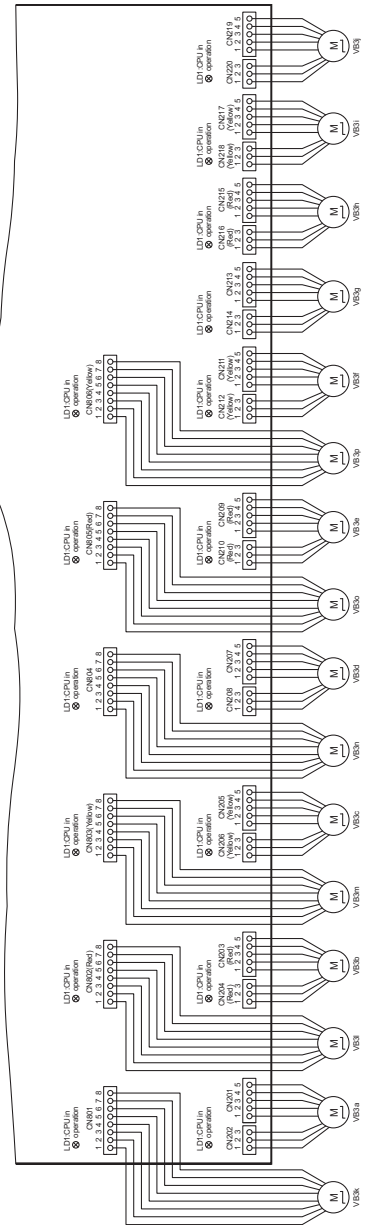
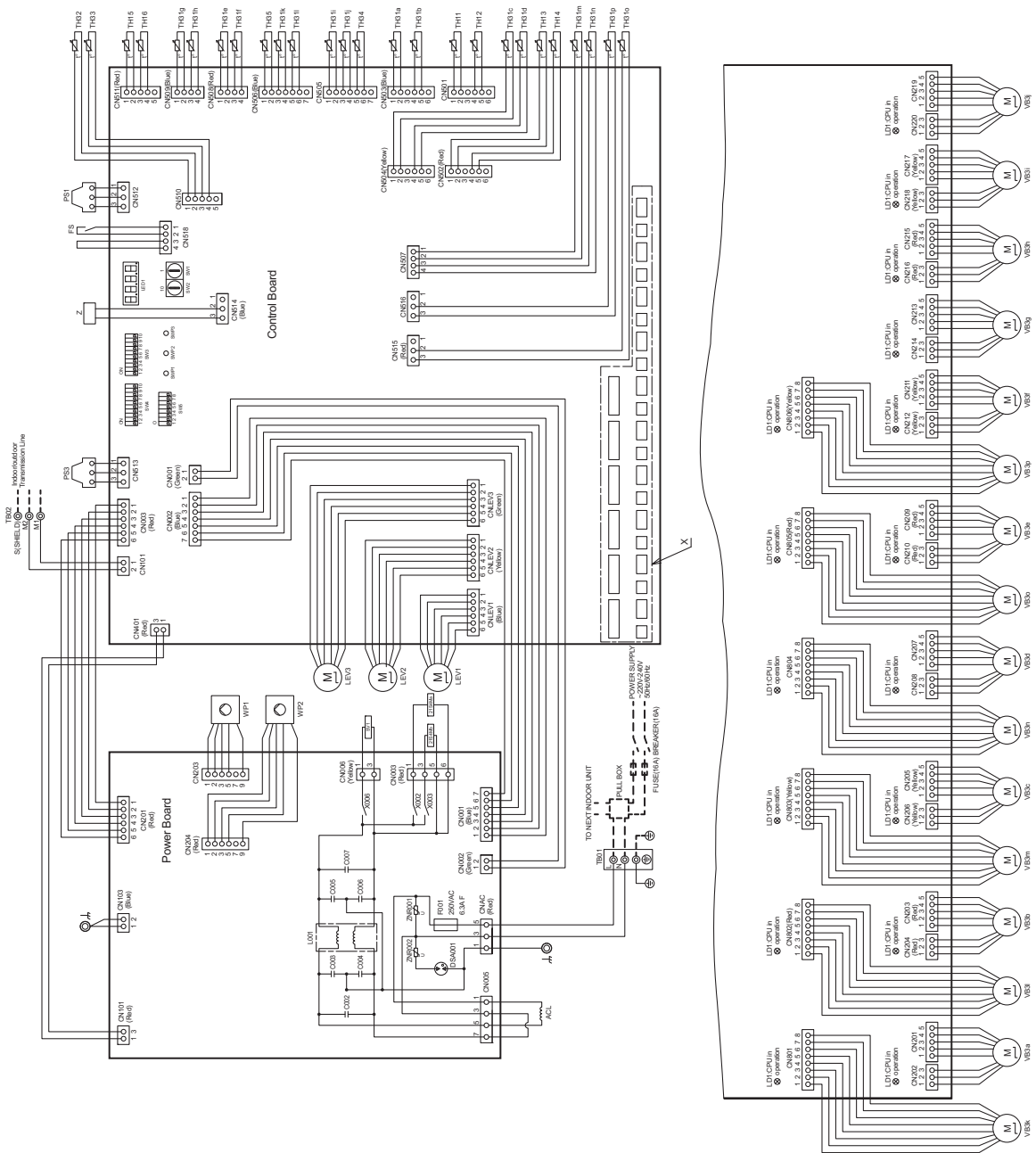

CMB-WM350, 500F-AA

(Symbol explanation)	Name
21S4Ma, 21S4Mb	4 way valve
ACL	AC reactor
C150, C165-C185, C168, C169, C170, C171	Capacitor
DSAD1-DSAD5	Arrestor
F01-F04	Fuse AC250V 8A
F10, F11	Fuse AC250V 15A
F10, F120	Fuse AC250V 6.3A
F121, F122	Fuse AC250V 3.15A
L10, L102	Reactor
LEVI-LEV3	Expansion Valve
MV1	3 way valve
NR01-NR03	Varistor
PS1, PS3, PWM1-PWM4	Pressure Sensor
SV1	Solenoid Valve
SWU01, SWU02, SWU1, SWU01-SWU03, SWU1, SWU02	Switch(Device Setting)
TB1	Terminal Block (for power source)
TB3	Terminal Block (for Transmission)
TH1-TH6, TH2-TH5, TH1a-TH3f	Thermister Sensor
VB3a-VB3f	Valve Block
WP1, WP2	Pump
X01-X03, X52	Auxiliary Relay
Z1, Z2	Function setting connector

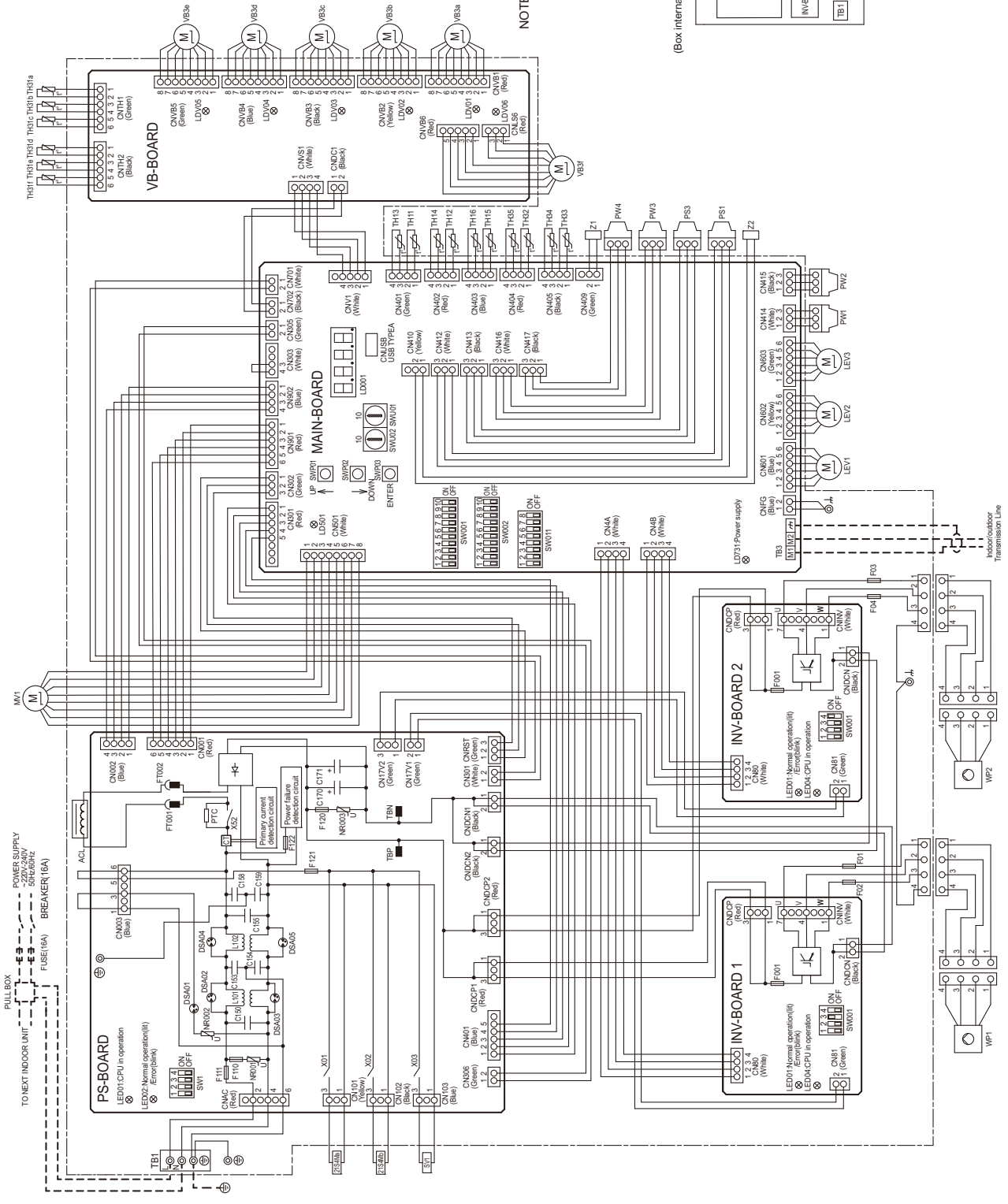

NOTE: 1. TB3 is transmission terminal block. Never connect power line to it.
 2. The initial set values of switch on Control Board are as follows.
 SWU01:0
 SWU02:0

3. The wirings to TB1 and TB3 shown in dotted line are field work.

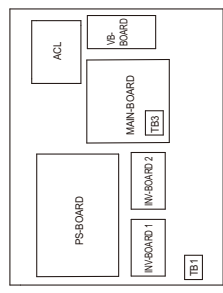

(Box internal layout)

CMB-WM108V-BB

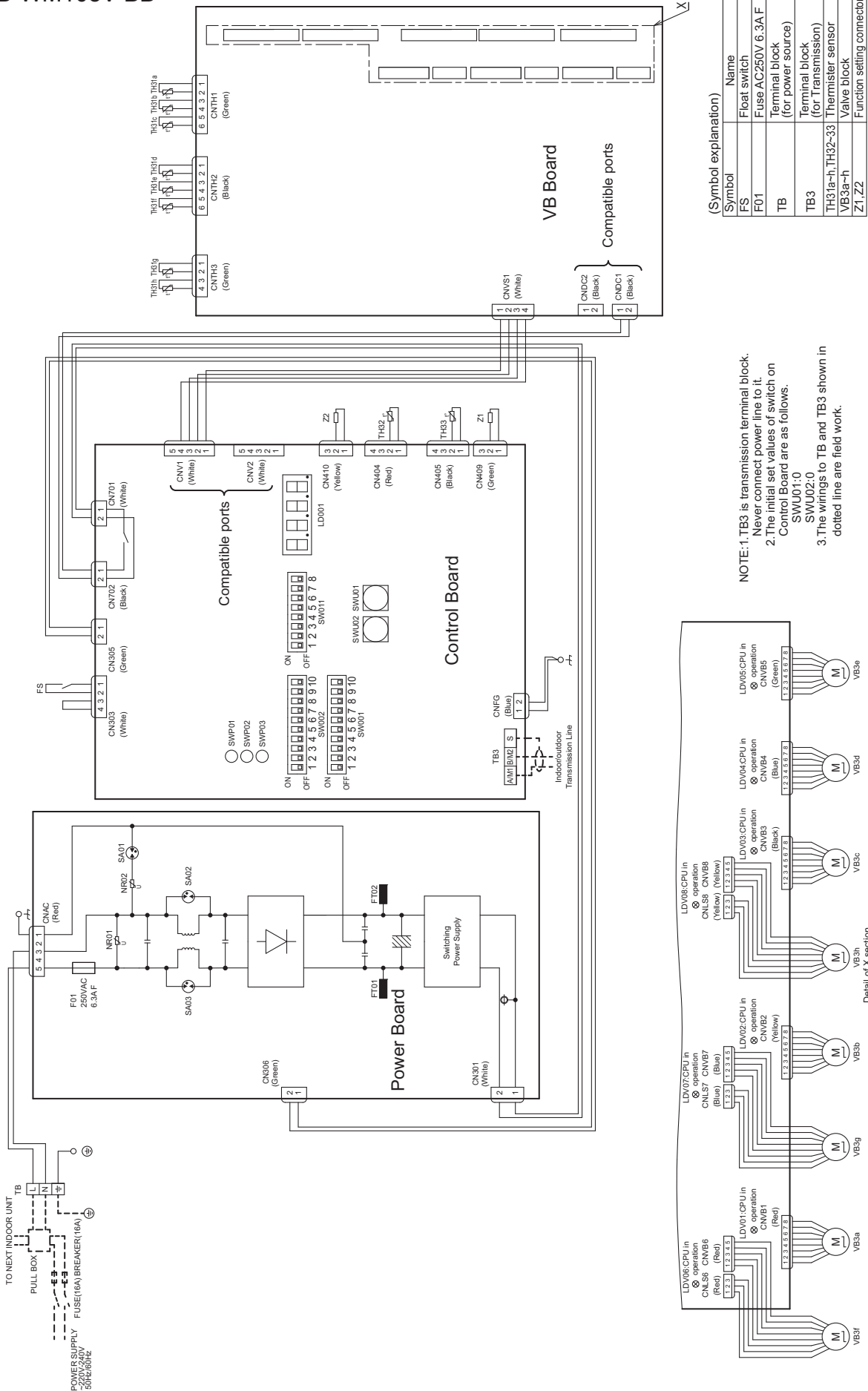

(Symbol explanation)

Symbol	Name
FS	Float switch
F01	Fuse AC250V 6.3A F
TB	Terminal block (for power source)
TB3	Terminal block (for Transmitter)
TH31a-h, TH32-33	Thermister sensor
VB3a-h	Valve block
Z1, Z2	Function setting connector

NOTE: 1. TB3 is transmission terminal block. Never connect power line to it.
 2. The initial set values of switch on Control Board are as follows.
 SWU01: 0
 SWU02: 0
 3. The wirings to TB and TB3 shown in dotted line are field work.

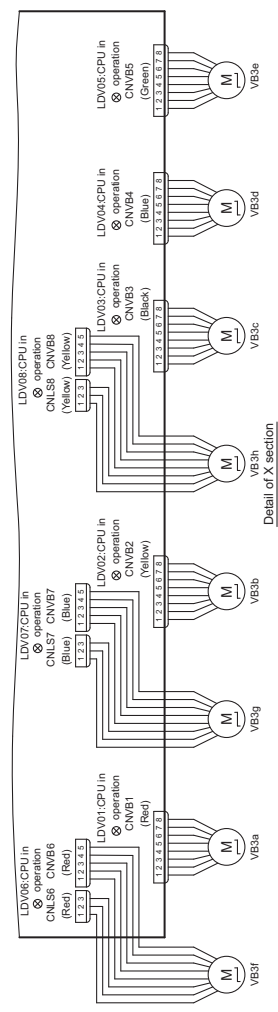

CMB-WM1016V-BB

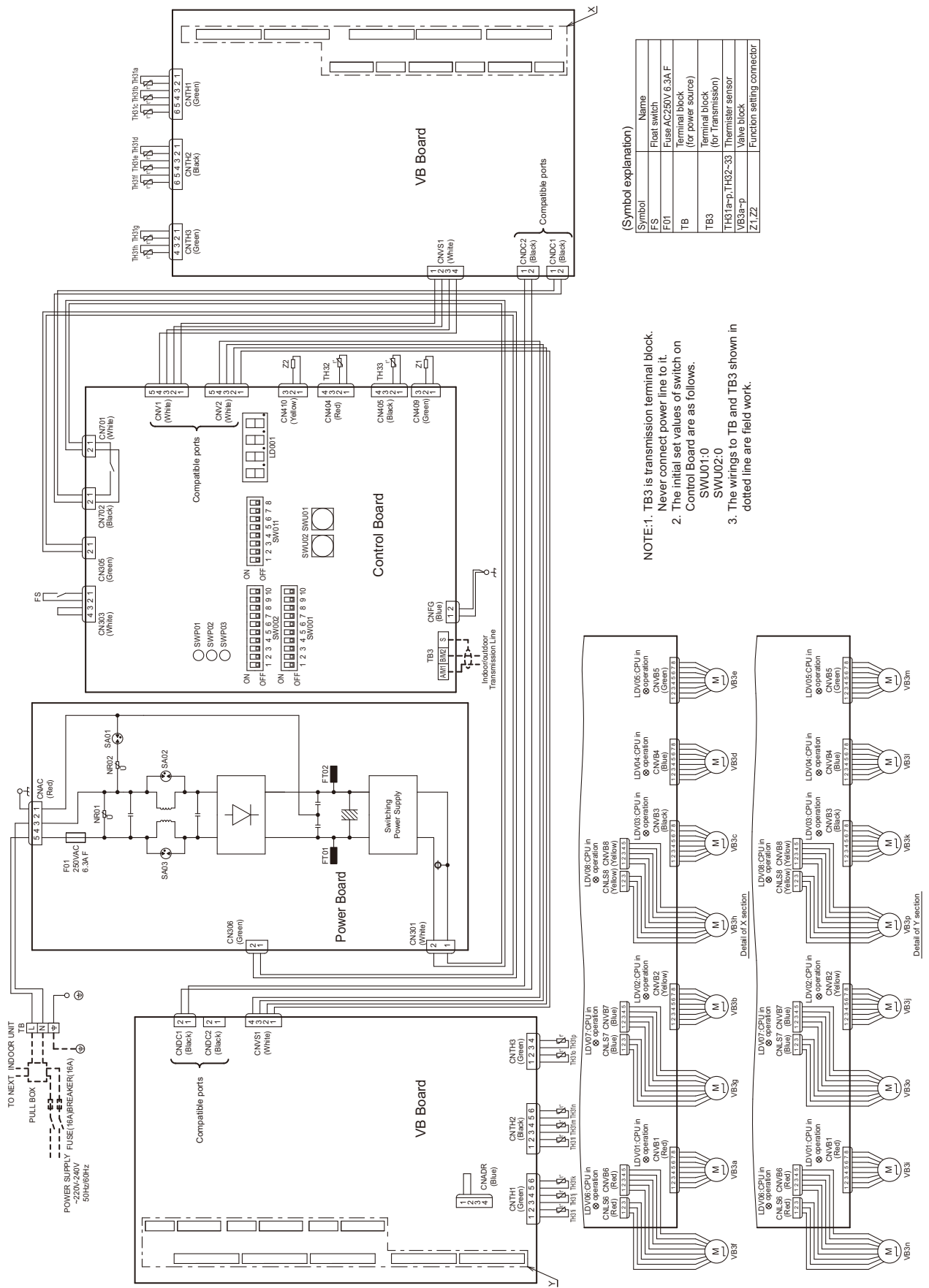

(Symbol explanation)

Symbol	Name
FS	Fuse switch
F01	Fuse AC250V 6.3A F
TB	Terminal block (for power source)
TB3	Terminal block (for Transmission)
TH31a-p, TH32-33	Thermister sensor
VB33a-p	Valve block
Z1, Z2	Function setting connector

- NOTE:1. TB3 is transmission terminal block. Never connect power line to it.
 2. The initial set values of switch on Control Board are as follows.
 SWU01-0
 SWU02-0
 3. The wirings to TB and TB3 shown in dotted line are field work.

HBC controller

5-1. Sound levels

(Measured point)

CMB-WM108V-AA
CMB-WM1016V-AA

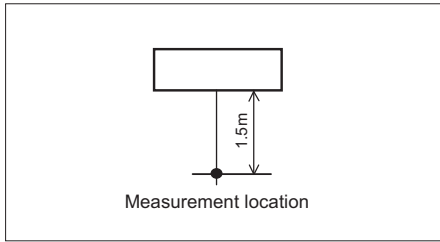

* Measured in anechoic room.

CMB-WM350F-AA
CMB-WM500F-AA

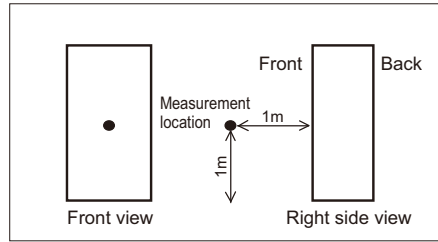

* Measured in anechoic room.

5-2. NC curves

CMB-WM108V-AA, CMB-WM1016V-AA

Power Source: 220-230-240V, 50/60Hz

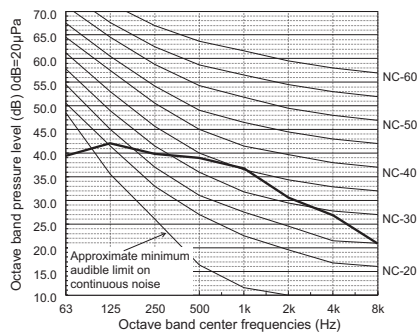

CMB-WM350F-AA, CMB-WM500F-AA

Power Source: 220-230-240V, 50/60Hz

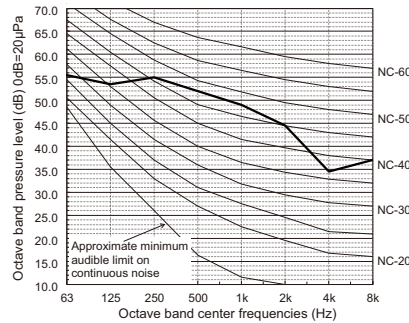

- For Horizontal type HBC, it is recommended to be installed in places such as ceilings of corridor, rest rooms and plant rooms.
- For Vertical type HBC, it is recommended to be installed in places such as machinery room and linen room.

6. ELECTRICAL CHARACTERISTICS

HBC controller

Symbols: MCA: Max. Circuit Amps, MFA: Max. Fuse Amps, RLA: Rated Load Amps

HBC controller	Power supply					RLA(A)
	Hz	Volts	Range+-10%	MCA(A)	MFA(A)	
CMB-WM108V-AA CMB-WM1016V-AA	50/60	220	Max.: 264V Min.: 198V	3.49	15	2.89
		230				2.83
		240				2.79
CMB-WM350F-AA CMB-WM500F-AA	50/60	220	Max.: 264V Min.: 198V	7.81	15	6.82
		230				6.52
		240				6.25
CMB-WM108V-BB CMB-WM1016V-BB	50/60	220	Max.: 264V Min.: 198V	0.17	15	0.14
		230				0.14
		240				0.14

HBC controller

Outdoor/Heat source unit	Main 1	Sub 1	Main 2	Sub 2	Compatibility
PURY-(E)P-YNW PURY-(E)P-YLM PQRY-P-YLM	WM-V-AA type	-	-	-	Compatible
	WP type	-	-	-	Compatible
	WM-V-AA type	WM-V-BB type	-	-	Compatible
	WM-V-AA type	WM-V-AB type	-	-	Compatible
	WM-V-AA type	WP type	-	-	Compatible
	WP type	WM-V-BB type	-	-	Compatible
	WP type	WM-V-AB type	-	-	Compatible
	WP type	WP type	-	-	Compatible
	WM-V-AA type	-	WM-V-AA type	-	Compatible
	WM-V-AA type	-	WP type	-	Compatible
	WP type	-	WM-V-AA type	-	Compatible
	WP type	-	WP type	-	Compatible
	WM-V-AA type	WM-V-BB type	WM-V-AA type	-	Compatible
	WM-V-AA type	WM-V-BB type	WP type	-	Compatible
	WM-V-AA type	WM-V-AB type	WM-V-AA type	-	Compatible
	WM-V-AA type	WM-V-AB type	WP type	-	Compatible
	WM-V-AA type	WP type	WM-V-AA type	-	Compatible
	WM-V-AA type	WP type	WP type	-	Compatible
	WP type	WM-V-BB type	WM-V-AA type	-	Compatible
	WP type	WM-V-BB type	WP type	-	Compatible
	WP type	WM-V-AB type	WM-V-AA type	-	Compatible
	WP type	WM-V-AB type	WP type	-	Compatible
	WP type	WP type	WM-V-AA type	-	Compatible
	WP type	WP type	WP type	-	Compatible
	WM-V-AA type	-	WM-V-AA type	WM-V-BB type	Compatible
	WM-V-AA type	-	WM-V-AA type	WM-V-AB type	Compatible
	WM-V-AA type	-	WM-V-AA type	WP type	Compatible
	WM-V-AA type	-	WP type	WM-V-BB type	Compatible
	WM-V-AA type	-	WP type	WM-V-AB type	Compatible
	WM-V-AA type	-	WP type	WP type	Compatible
	WP type	-	WM-V-AA type	WM-V-BB type	Compatible
	WP type	-	WM-V-AA type	WM-V-AB type	Compatible
	WP type	-	WP type	WP type	Compatible
	WP type	-	WP type	WM-V-BB type	Compatible
	WP type	-	WP type	WM-V-AB type	Compatible
	WM-V-AA type	WM-V-BB type	WM-V-AA type	WM-V-BB type	Compatible
	WM-V-AA type	WM-V-BB type	WM-V-AA type	WM-V-AB type	Compatible
	WM-V-AA type	WM-V-BB type	WP type	WM-V-BB type	Compatible
	WM-V-AA type	WM-V-BB type	WP type	WM-V-AB type	Compatible
	WM-V-AA type	WM-V-BB type	WP type	WP type	Compatible
	WM-V-AA type	WM-V-AB type	WM-V-AA type	WM-V-BB type	Compatible
	WM-V-AA type	WM-V-AB type	WM-V-AA type	WM-V-AB type	Compatible
	WM-V-AA type	WM-V-AB type	WM-V-AA type	WP type	Compatible
	WM-V-AA type	WM-V-AB type	WP type	WM-V-BB type	Compatible
	WM-V-AA type	WM-V-AB type	WP type	WM-V-AB type	Compatible
	WM-V-AA type	WM-V-AB type	WP type	WP type	Compatible
	WM-V-AA type	WP type	WM-V-AA type	WM-V-BB type	Compatible
	WM-V-AA type	WP type	WM-V-AA type	WM-V-AB type	Compatible
	WM-V-AA type	WP type	WM-V-AA type	WP type	Compatible
	WM-V-AA type	WP type	WP type	WM-V-BB type	Compatible
WM-V-AA type	WP type	WP type	WM-V-AB type	Compatible	
WP type	WM-V-BB type	WM-V-AA type	WM-V-BB type	Compatible	
WP type	WM-V-BB type	WM-V-AA type	WM-V-AB type	Compatible	
WP type	WM-V-BB type	WM-V-AA type	WP type	Compatible	
WP type	WM-V-BB type	WP type	WM-V-BB type	Compatible	
WP type	WM-V-BB type	WP type	WM-V-AB type	Compatible	
WP type	WM-V-BB type	WP type	WP type	Compatible	
WP type	WM-V-AB type	WM-V-AA type	WM-V-BB type	Compatible	
WP type	WM-V-AB type	WM-V-AA type	WM-V-AB type	Compatible	
WP type	WM-V-AB type	WM-V-AA type	WP type	Compatible	
WP type	WM-V-AB type	WP type	WM-V-BB type	Compatible	
WP type	WM-V-AB type	WP type	WM-V-AB type	Compatible	
WP type	WM-V-AB type	WP type	WP type	Compatible	
WP type	WP type	WM-V-AA type	WM-V-BB type	Compatible	
WP type	WP type	WM-V-AA type	WM-V-AB type	Compatible	
WP type	WP type	WM-V-AA type	WP type	Compatible	
WP type	WP type	WP type	WM-V-BB type	Compatible	
WP type	WP type	WP type	WM-V-AB type	Compatible	
WP type	WP type	WP type	WP type	Compatible	

HBC controller

Outdoor/Heat source unit	Main 1	Sub 1	Sub 2	Sub 3	Compatibility
PURY-(E)P-YNW PURY-(E)P-YLM PQRY-P-YLM	WM-F-AA type	-	-	-	Not compatible
	WM-F-AA type	WM-V-BB type	-	-	Not compatible
	WM-F-AA type	WM-V-AB type	-	-	Not compatible
	WM-F-AA type	WP type	-	-	Not compatible
	WM-F-AA type	WM-V-BB type	WM-V-BB type	-	Not compatible
	WM-F-AA type	WM-V-BB type	WM-V-AB type	-	Not compatible
	WM-F-AA type	WM-V-BB type	WP type	-	Not compatible
	WM-F-AA type	WM-V-AB type	WM-V-BB type	-	Not compatible
	WM-F-AA type	WM-V-AB type	WM-V-AB type	-	Not compatible
	WM-F-AA type	WM-V-AB type	WP type	-	Not compatible
	WM-F-AA type	WP type	WM-V-BB type	-	Not compatible
	WM-F-AA type	WP type	WM-V-AB type	-	Not compatible
	WM-F-AA type	WP type	WP type	-	Not compatible
	WM-F-AA type	WM-V-BB type	WM-V-BB type	WM-V-BB type	Not compatible
	WM-F-AA type	WM-V-BB type	WM-V-BB type	WM-V-AB type	Not compatible
	WM-F-AA type	WM-V-BB type	WM-V-BB type	WP type	Not compatible
	WM-F-AA type	WM-V-BB type	WM-V-AB type	WM-V-BB type	Not compatible
	WM-F-AA type	WM-V-BB type	WM-V-AB type	WM-V-AB type	Not compatible
	WM-F-AA type	WM-V-BB type	WM-V-AB type	WP type	Not compatible
	WM-F-AA type	WM-V-BB type	WP type	WM-V-BB type	Not compatible
	WM-F-AA type	WM-V-BB type	WP type	WM-V-AB type	Not compatible
	WM-F-AA type	WM-V-AB type	WM-V-BB type	WM-V-BB type	Not compatible
	WM-F-AA type	WM-V-AB type	WM-V-BB type	WM-V-AB type	Not compatible
	WM-F-AA type	WM-V-AB type	WM-V-BB type	WP type	Not compatible
	WM-F-AA type	WM-V-AB type	WM-V-AB type	WM-V-BB type	Not compatible
	WM-F-AA type	WM-V-AB type	WM-V-AB type	WM-V-AB type	Not compatible
	WM-F-AA type	WM-V-AB type	WM-V-AB type	WP type	Not compatible
	WM-F-AA type	WM-V-AB type	WP type	WM-V-BB type	Not compatible
	WM-F-AA type	WM-V-AB type	WP type	WM-V-AB type	Not compatible
	WM-F-AA type	WP type	WM-V-BB type	WM-V-BB type	Not compatible
	WM-F-AA type	WP type	WM-V-BB type	WM-V-AB type	Not compatible
	WM-F-AA type	WP type	WM-V-BB type	WP type	Not compatible
	WM-F-AA type	WP type	WM-V-AB type	WM-V-BB type	Not compatible
	WM-F-AA type	WP type	WM-V-AB type	WM-V-AB type	Not compatible
	WM-F-AA type	WP type	WM-V-AB type	WP type	Not compatible
	WM-F-AA type	WP type	WP type	WM-V-BB type	Not compatible
	WM-F-AA type	WP type	WP type	WM-V-AB type	Not compatible
	WM-F-AA type	WP type	WP type	WP type	Not compatible

HBC controller

⚠ Warning

- Do not use refrigerant other than the type indicated in the manuals provided with the unit and on the nameplate.
 - Doing so may cause the unit or pipes to burst, or result in explosion or fire during use, repair, or at the time of disposal of the unit.
 - It may also be in violation of applicable laws.
 - MITSUBISHI ELECTRIC CORPORATION cannot be held responsible for malfunctions or accidents resulting from the use of the wrong type of refrigerant.
- Our air conditioning equipment and heat pumps contain a fluorinated greenhouse gas, R410A/R32.

MITSUBISHI ELECTRIC CORPORATION

www.MitsubishiElectric.com