

Data Book

NX2-N-G06 0344 - 0808_202105_EN R454B
ELCA_Engine ver.4.5.4.0



NX2-N-G06 0344 - 0808

316-799 kW
Reversible unit, air source for outdoor installation

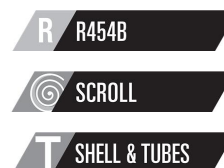

(The photo of the unit is indicative and may vary depending on the model)

- ✓ LOW GWP REFRIGERANT
- ✓ SHELL&TUBE HEAT EXCHANGER
- ✓ INTEGRATED HYDRONIC MODULE
- ✓ VARIABLE PRIMARY FLOW
- ✓ ELECTRONIC EXPANSION VALVE SUPPLIED STANDARD
- ✓ WIDE OPERATING RANGE
- ✓ WIDE CAPACITY RANGE

1	CERTIFICATIONS	pg.5
1.1	Product certifications	pg.5
1.2	Voluntary product certifications	pg.5
1.3	System certifications	pg.5
2	PRODUCT PRESENTATION	pg.7
2.1	Green certification relevant	pg.7
2.2	Unit description	pg.8
2.3	Key features	pg.8
3	INCIPIIT	pg.10
4	UNIT DESCRIPTION	pg.11
4.1	Standard unit composition	pg.11
4.2	Versions	pg.15
4.3	Configurations	pg.15
4.4	Electronic controller	pg.16
5	OPTIONS	pg.19
5.1	Options	pg.19
5.2	Options - additional information	pg.31
6	GENERAL TECHNICAL DATA	pg.35
7	TECHNICAL DATA SEASONAL EFFICIENCY IN HEATING (EN14825 VALUE)	pg.39
8	TECHNICAL DATA SEASONAL EFFICIENCY IN COOLING (EN14825 VALUE)	pg.42
9	OPERATING LIMITS	pg.43
9.1	Operating limits - graphs	pg.43
10	HYDRAULIC DATA	pg.49
11	ELECTRIC DATA	pg.51
11.1	Electrical data	pg.51
11.2	Dimensions of the electrical connections to the main switch	pg.54
12	FULL LOAD SOUND LEVEL	pg.55
13	DIMENSIONAL DRAWINGS	pg.61

13.1 Dimensional drawings	pg.61
13.2 Legend of pipe connections	pg.64
14 HYDRONIC KIT	pg.66
14.1 Hydronic groups	pg.66
15 ATTACHMENTS	pg.89
15.1 Variable flow control	pg.89

Liability disclaimer

The present publication is drawn up by of information only and does not constitute an offer binding upon Mitsubishi Electric Hydronics & IT Cooling Systems S.p.A.

Mitsubishi Electric Hydronics & IT Cooling Systems S.p.A. has compiled the content of this publication to the best of its knowledge. The data contained herein are subject to change without notice. Mitsubishi Electric Hydronics & IT Cooling Systems S.p.A. explicitly rejects any liability for any direct or indirect damage, in the broadest sense, arising from or related to the use and/or interpretation of this publication. All content is copyrighted by Mitsubishi Electric Hydronics & IT Cooling Systems S.p.A.

The units highlighted in this publication contain R454B [GWP₁₀₀ 467] fluorinated greenhouse gases.

LEGEND

Data Book
 NX2-N-G06 0344 - 0808_202105_EN R454B

Functions

 COOLING	Cooling
 HEATING	Heating

Refrigerant

R R454B	R454B
-----------------------	-------

Compressors

 SCROLL	Scroll compressor
---	-------------------

Fan

 AXIAL	Axial fan
--	-----------

Exchangers

T SHELL & TUBES	Shell & Tubes
-----------------------------------	---------------

Other features

	Eurovent
---	----------

	VPF
---	-----

	Electronic Expansion Valve
---	----------------------------

1 CERTIFICATIONS

Data Book
NX2-N-G06 0344 - 0808_202105_EN R454B

1.1 Product certifications



1.2 Voluntary product certifications



Check ongoing validity of certificate:
www.eurovent-certification.com
or
www.certiflash.com

1.3 System certifications



Quality System complying with the requirements of UNI EN ISO9001:2008 regulation

CERTIFICATIONS

Data Book

NX2-N-G06 0344 - 0808_202105_EN R454B



Environmental Management System complying with the requirements of UNI EN ISO14001:2004 regulation



Occupational Health and Safety Management System complying with the requirements of BS OHSAS 18001:2007

2.1 Green certification relevant

FOCUS ON GREEN CERTIFICATION RELEVANT

Mitsubishi Electric Hydronics & IT Cooling Systems S.p.A., as a major player in the world HVAC market and a leading manufacturer of energy efficient, sustainable HVAC solutions, recognizes and supports the diffusion of green certification systems, as an effective way to deliver high performance buildings and improve the quality and the sustainability of the built environment.

Since the first certification system was introduced at the beginning of the 1990s, the demand for certified buildings has grown considerably, as well as the number of standards, rating and certification programs. Operating worldwide Mitsubishi Electric Hydronics & IT Cooling Systems S.p.A., has extensive experience with many of them and is active member of Green Building Council Italy.

Mitsubishi Electric Hydronics & IT Cooling Systems S.p.A., commitment to develop responsible and sustainable HVAC solutions, is reflected by a full range of premium efficiency products and systems, designed with special care to improve building energy performance ratings, according to major certification protocols, including LEED, BREAM, GREENSTAR, BCA, NABERS, DNGB, HQE and BEAM.

To find out more about how our products contribute to enhanced green certification rating and energy performance of a building, please refer to:
https://www.melcohit.com/EN/Environment/green_certifications/



2.2 Unit Description

Outdoor heat pump for the production of chilled/hot water with hermetic rotary Scroll compressors, ozone-friendly refrigerant R454B, axial-flow fans, shell and tubes exchanger and electronic expansion valve. The range is composed by units equipped with four, six and eight compressors in multi-circuit configuration.

2.3 Key Features

LOW GWP REFRIGERANT

The new generation refrigerant R454B is the most eco-sustainable alternative to traditional refrigerant R410A, offering a 76% reduction in terms of GWP (Global Warming Potential GWP of R454B = 467, GWP of R410A = 1924 as per IPCC rev. 5th) and zero impact on the ozone layer.

SHELL&TUBE HEAT EXCHANGER

The shell and tube exchanger provides the highest flexibility for the unit's installation, keeping the pressure drops on the hydronic side at a minimum, thus representing the best choice for all the hydronic applications.

INTEGRATED HYDRONIC MODULE

The built-in hydronic module already contains the main water circuit components; it is available as option with single or twin in-line pump, for achieving low or high head, fixed or variable speed and buffer tank.

VARIABLE PRIMARY FLOW

Energy savings due to variable pump speed management based on load demand and the variable flow ensures the units also function in critical working conditions.

ELECTRONIC EXPANSION VALVE SUPPLIED STANDARD

The use of the electronic expansion valve generates considerable benefits, especially in cases of variable demand and at different working conditions. It guarantees energy savings due to efficiency optimization in various different working conditions which translates into a reduction in operating consumption, a faster start-up of the unit and a wider extension of the operating limits.

WIDE OPERATING RANGE

Unit's operation guaranteed with external air temperature down to -15°C during winter and up to 46°C during summer. Production of hot water up to 55°C without accessories.

WIDE CAPACITY RANGE

Units equipped with up to 8 scroll compressors in multi-circuits configuration for a wide capacity range, up to 800 kW of cooling capacity.

PATENTED VENTILATION SECTION LAYOUT

Technological solution patented by MEHITS to ensure the independent operation of the circuits, reduce the unit's footprint and improve the efficiency at partial load both in heating mode and cooling mode.

NX2-N-G06 / D / SL / 0546

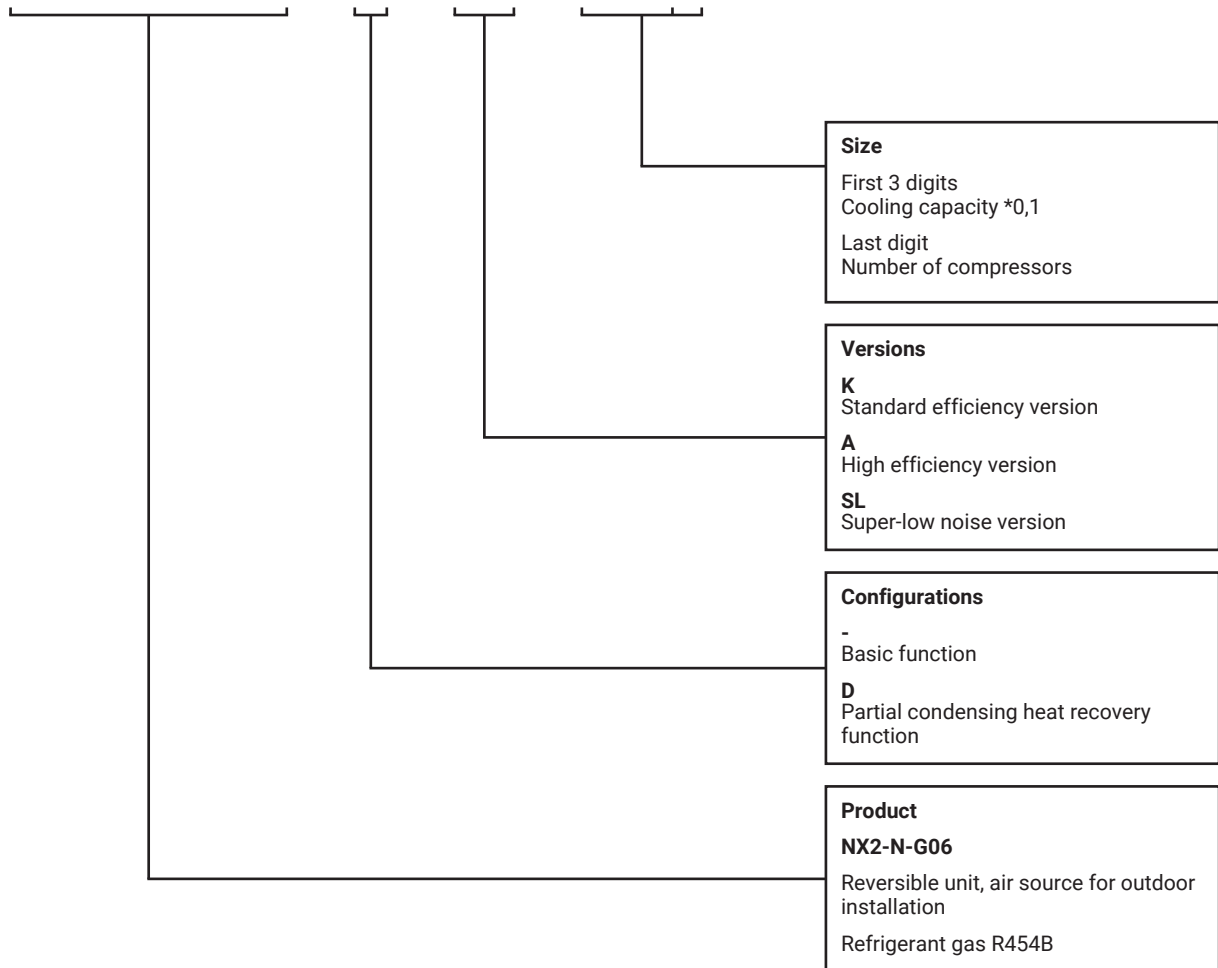

4 UNIT DESCRIPTION

Data Book

NX2-N-G06 0344 - 0808_202105_EN R454B

4.1 Standard unit composition

Reversible unit, air source for outdoor installation

Outdoor heat pump for the production of chilled/hot water with hermetic rotary Scroll compressors, ozone-friendly refrigerant R454B, axial-flow fans, shell and tubes exchanger and electronic expansion valve. The range is composed by units equipped with four, six and eight compressors in multi-circuit configuration.

The unit is supplied fully refrigerant charged and factory tested. On site installation only requires power and hydraulic connection.

Structure

Structure specifically designed for outdoor installation. Base and frame in hot-galvanised shaped sheet steel with a suitable thickness. All parts polyester-powder painted to assure total weather resistance.

Refrigerant circuit

Main components of the cooling circuit:

- R454B refrigerant
- two to four circuits with tandem compressors for each circuit
- electronic expansion valve
- liquid line shut-off valve
- drier filter with replaceable cartridge
- refrigerant line sight glass with humidity indicator
- high and low pressure safety valve
- high and low pressure transducers
- High pressure switches
- Liquid receivers
- antifreeze electric heater for heat exchangers
- 4-way reverse cycle valve
- refrigerant line sight glass with humidity indicator
- crankcase heater on each compressor

UNIT DESCRIPTION

Data Book

NX2-N-G06 0344 - 0808_202105_EN R454B

R454B REFRIGERANT

The refrigerant used in these units is R454B, one of the most eco-sustainable refrigerants for replacing traditional R410A, thanks to the 76% lower GWP.

Unlike R410A, R454B is classified as A2L according to ISO 817. The first digit defines toxicity (A: NON-TOXIC), while the last digits define the flammability level (2L: MILDLY FLAMMABLE - low burning velocity). It is classified by PED Directive into Group 1.

The main characteristics of this refrigerant and some additional guidelines are reported below. Despite the minimal risk, the indications provided cannot replace a more detailed risk analysis if required, also based on any regulations in force in the installation area.

Further and more detailed guidelines are available in the dedicated area of the website www.melcohit.com (Guidelines) or in the dedicated addendum of the general installation and maintenance manual.

Main characteristics of R454B refrigerant:

- Safety classification (ASHRAE / ISO 817): A2L
- PED Group: 1
- Ozone Depletion Potential (ODP) (R11=1): 0
- AR5 (AR4) GWP (CO2=1): 467 (466)
- Composition (Wt %): 68,9% R32, 31,1% R1234yf
- LFL@23°C, 50% RH (% v/v): 11,7
- UFL@23°C, 50% RH (% v/v): 22,0
- Burning velocity (cm/s): 5,2
- Minimum Ignition Energy (mJ) (ASTM E582-13): 100-300

- All operations on the unit must be performed by trained and qualified personnel on flammable refrigerants handling, in accordance with the relevant local standards and codes of practice.
- The refrigerant is heavier than air and can stagnate, reaching a dangerous concentration. To avoid risks, maintain a safe environment by ensuring adequate ventilation.
- The units must be installed in such a way as to prevent any refrigerant leaks from flowing into the buildings or any place where it could cause damage to people, animals or properties. Pay particular attention to the presence and disposition of any external air intakes, doors, shutters, etc.
- The units are equipped with conveyed safety valves with external discharge. In case of over-pressure, refrigerant gas can escape from these valves: the discharge of these ducts must be directed towards safe areas and away from the ground or potential sources of ignition.
- Do not braze pipes and components containing refrigerant.
- Do not use flames to cut / open pipes.
- The units are equipped with a safety valve (water side). In case of breakage of the heat exchanger and resulting overpressure, refrigerant gas can escape from these valves: the discharge of these valves must be directed towards safe areas and away from the ground or potential sources of ignition.
- The hydraulic circuit must be designed in such a way as to prevent the release of refrigerant gas inside the buildings or in any case in places where it can cause damage to people, animals or properties.

Compressor

Hermetic scroll compressors in tandem layout complete with oil sump heater, electronic overheating protection with centralised manual reset and a two-pole electric motor.

Plant side heat exchanger

Direct expansion multi-circuit shell and tube exchanger with asymmetric side coolant flows for maintaining the coolant at the correct speed inside the tubes when passing from the liquid to the gas phase. Steel shell with foamed closed-cell elastomer anti-condensation lining. The shell & tube is manufactured using copper tubes with internal grooves for favouring heat exchange and mechanically expanded onto the tube plates. An electric antifreeze heater prevents the ice from forming inside the exchanger when the unit is not working but connected to the electrical supply. When the unit is working, it is protected by a differential pressure switch mounted on the water side. Heat exchanger featuring two, three or four coolant circuits depending on the model.

UNIT DESCRIPTION

Data Book

NX2-N-G06 0344 - 0808_202105_EN R454B

Source side heat exchanger

Finned coil exchanger made from copper tubes and aluminium fins. The aluminium fins are correctly spaced to guarantee optimum heat exchange efficiency. The differentiated circulation suitably distributes the liquid in the coil during the expansion phase. Coil with a sideways-V layout and diaphragm separating the fan chamber to ensure that the adjacent circuits are independently ventilated.

Patented ventilation section layout

NX2-N multiscroll units are available with a V-shaped modular frame where every module includes two finned coils.

Generally, the module is made up of a single row of 800mm-diameter fans, while in the case of NX2-N units, to ensure the independent operation of the two coils, one or more modules can be made of two rows of 450mm-diameter fans separated by a vertical baffle.

In this way the independence of the circuits sharing the same "V" module is safeguarded during the operation at partial load and particularly during the defrost phase.

The advantages of this technological solution patented by MEHITS are:

- Increased part load efficiency both in summer and in winter
- Increased heating capacity thanks to the independent and not simultaneous defrost cycles
- Stable outlet water temperature delivered during defrosting
- Reduced footprint

This fans section configuration is available in the following NX2-N models

Version K: 0344, 0364, 0404, 0446, 0506, 0526, 0546

Version SL: 0344, 0446, 0506, 0526

Version A: 0446

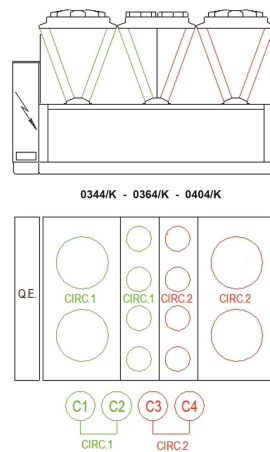

Fan section source side

Axial electric fans protected to IP54 and with insulation class 'F', featuring an external rotor and profiled blades. Housed in an aerodynamic hood complete with safety guard. The fan + outlet set satisfies the efficiency requirements provided for by EcoDesign directive 327/11.

Variable Speed low-temperature Device (DVV), as standard, to control condensation adjusting the rotational speed by phase-cut devices.

UNIT DESCRIPTION

Data Book

NX2-N-G06 0344 - 0808_202105_EN R454B

EC fans: Axial electronically commutated fans (EC fans), with external rotor, profiled die-cast aluminium blades, housed in aerodynamic hoods complete with guard grille. 6-poles electric motor with built-in thermal protection. The brushless motor, governed by a special controller, continuously adjust fans' speed to minimize energy consumption, electromagnetic noises and current's absorption even during start-up phase.

- Standard for version /A units from size 0606 to size 0808;
- Available as option for version /K units, version /SL units and all the others sizes /A.

Electrical and control panel

Electrical and control panel built in accordance with EN60204-1 standard, complete with:

- Electronic control W3000+
- power circuit with electric bus bar distribution system
- fuses and contactors for compressors and fans
- auxiliary 4-20mA analogue input
- terminals for cumulative alarm block
- remote ON/OFF terminals
- general door lock isolator
- control circuit transformer
- Outdoor air temperature probe
- Phases sequence control
- spring-type control circuit terminal board
- Pump control relay + 0-10V modulating signal to control an external variable speed pump with the VPF.E control logic (plant-side constant ΔT for plants with primary circuit only and terminals with bypass)

Certification and applicable directives

The unit complies with the following directives and relative amendments:

- EUROVENT Certification program
- CE - Declaration of conformity certificate for the European Union
- Machinery Directive 2006/42/EC
- Pressure Equipment Directive 2014/68/EU
- 2014/30/EC EMC Directive
- ErP Directive 2009/125/EC

Tests

Tests performed throughout the production process, as indicated in ISO9001.

Performance or noise tests can be performed by highly qualified staff in the presence of customers.

Performance tests comprise the measurement of:

- electrical data
- water flow rates
- working temperatures
- power input
- power output
- pressure drops on the water-side exchanger both at full load (at the conditions of selection and at the most critical conditions for the condenser) and at part load conditions.

During performance testing it is also possible to simulate the main alarm states.

Noise tests are performed to check noise emissions according to ISO9614.

UNIT DESCRIPTION

Data Book

NX2-N-G06 0344 - 0808_202105_EN R454B

4.2 Versions

/K - Key efficiency

Key efficiency units grant the best cooling capacity/footprint ratio.

/A - High efficiency

High efficiency units with minimum investment payback time. High performing heat exchangers and generous heat exchanger surfaces.

/SL - Super Low noise

This configuration features a special soundproofing for the compressor compartment and the pumps (if present), a reduced fan speed and an oversized condensing section.

The fan speed is automatically increased in case of particularly tough environmental conditions.

4.3 Configurations

- , standard unit

Reversible standard unit for production of chilled/hot water according to the selected operation mode.

/D, unit with partial heat recovery

Unit for the production of water for the primary circuit and for sanitary purposes.

This version features an additional water/coolant heat exchanger on the gas delivery line, fitted in series with the traditional cooling circuit condenser. This allows to recover the de-superheating heat for the production of medium-to-high temperature water (secondary or recovery circuit). Hot water can be produced in the recovery circuit for domestic hot water and the like both in summer and winter. The heating capacity of this circuit is approximately equal to the power input of the compressor.

UNIT DESCRIPTION

Data Book

NX2-N-G06 0344 - 0808_202105_EN R454B

4.4 Electronic controller

Electronic control W3000+

W3000+ features an easy-to-use interface and a complete LCD display that allows one to consult and intervene by means of a multi-language menu (19 languages are available). The diagnostics includes a complete alarm management, with the "black-box" and the alarm history display for enhanced analysis of the unit operation. The programmable timer manages a weekly schedule organized into time bands to optimize unit performance by minimizing power consumption during periods of inactivity. Up to 10 daily time bands can be associated with different operating set points. As option, KIPlink is available - Keyboard In Your Pocket. KIPlink is the innovative user interface based on WiFi technology that allows one to operate on the unit directly from the smartphone or tablet.

The regulation is based on the patented "Quickmind" water temperature regulation logic uses self-adapting control to maintain flow temperatures and optimize performance even in low water content scenarios. As an alternative, the proportional or proportional-integral regulations are also available.

Optional proprietary devices can perform the adjustment of resources in systems made of several units. Consumption metering and performance measurement are possible as well. The variable primary flow control is always available as per standard (VPF.E function).

Supervision can be easily developed via proprietary devices or the integration in third party systems by means of the most common protocols as ModBus, Echelon, Bacnet-over-IP, Bacnet MS/TP RS485, Konnex, ModBus TCP/IP, SNMP, M-net network. Compatibility with the remote keyboard (up to 8 units).



UNIT DESCRIPTION

Data Book

NX2-N-G06 0344 - 0808_202105_EN R454B

Touch screen (option 6195)

As an alternative to the Compact keyboard, the unit can be equipped with the Touch interface, with a 7" WVGA colour display and a front USB port. The touch-screen's technology is characterized by an easy-to-access data, and it allows an effective graphical representation of the main figures protecting the access through 3 privilege levels.

**KIPlink - Keyboard In your Pocket (option 6196)**

KIPlink - Keyboard In Your Pocket - is the innovative user interface based on WiFi technology that allows one to operate on the unit directly from the smartphone or tablet. Using KIPlink, it is possible to turn the unit on and off, adjust the set-point, plot the main operating variables, monitor in detail the status of the refrigerant circuits, the compressors, the fans (if present) and the pumps (if present) and display and reset the possible alarms.



UNIT DESCRIPTION

Data Book

NX2-N-G06 0344 - 0808_202105_EN R454B

Night mode (option 1430)

The night mode function allows to reduce the sound power of the unit, reducing the speed of the fans and the number of active compressors.

U.L.C. - User limit control (option 4960)

Guaranteed the start-up of the units with the option U.L.C. even when the critical working condition could generate an alarm.

The controller can manage a 3way mixing valve (not provided) by 0-10V signal for ensuring a dynamic control of the water temperature on user heat exchanger according to the operating limits allowed. This ensures the start-up and correct functioning of the unit into the envelope, also even critical whether condition.

5 OPTIONS

Data Book

NX2-N-G06 0344 - 0808_202105_EN R454B

OPTIONS	DESCRIPTIONS	BENEFITS	AVAILABLE FOR MODELS
1020 REGULATIONS			
1015 HEAT EXCHANGERS NSW CERTIFIED	Heat exchangers with SafeWork NSW certificate		ALL
1016 UNIT WITH PED RULES	Unit according to PED (Pressure Equipment Directive) rules		ALL
380 NUMBERED WIRING			
381 NUMBERED WIRING ON EL. BOARD	Electrical board wires are identified by numbered labels. The reference numbers are indicated in the unit's wiring scheme.	Facilitate maintenance interventions to the electrical board connections.	ALL
383 NUMBERED WIRINGS+UK REQUESTS	Electrical board wires are identified by numbered labels. The reference numbers are indicated in the unit's wiring scheme.	Facilitate maintenance interventions to the electrical board connections.	ALL
2410 PHASE SEQUENCE RELAY			
2411 WITH EXTERNAL PHASE SEQUENCE RELAY	Relay for checking mains phase-sequence	Protects loads against faults due to incorrect connection of mains	ALL
2412 PHASE SEQU. RELAY + OVER/UNDER VOLT. MONIT.	Relay for checking mains phase-sequence and voltage	The monitoring relay protects loads against faults due to incorrect connection of mains, and it monitors whether it exceeds or falls below a specified voltage in a three-phase network.	ALL
3410 AUTOMATIC CIRCUIT BREAKERS			
3412 AUTOM. CIRCUIT BREAK. ON LOADS	Over-current switch on the major electrical loads.	In case of overcurrent allows resetting of the switch without the replacement of relative fuses.	ALL
3600 COMPRESSOR RUN STATUS SIGNAL			
3601 COMPRESSOR OPERATION SIGNAL	Auxiliary contacts providing a voltage-free signal.	Allows remote signalling of compressor's activation or remote control of any auxiliary loads.	ALL
4160 WINTER/SUMMER SWITCHOVER			
4161 REMOTE SUMMER/WINTER SWITCH	Digital input (voltage free)	Allows to change the operating mode (Cooling/Heating) according to a remote switch	ALL
4180 REMOTE CONNECTION ARRANGEMENT			
4181 SERIAL CARD MODBUS	Interface module for ModBUS protocols.	Allows integration with BMS operating with ModBUS protocol.	ALL
4182 SERIAL CARD FOR LONWORKS	Interface module for Echelon systems.	Allows integration with BMS operating with LonWorks protocols	ALL
4184 SERIAL CARD BACNET MS/TP RS485	Interface module for BACnet protocols.	Allows integration with BMS operating with BACnet protocol.	ALL
4185 SERIAL CARD FOR BACNET OVER IP	Interface module for BACnet OVER-IP protocols.	Allows to interconnect BACnet devices over Internet Protocol within wide-area networks.	ALL
4186 SERIAL CARD FOR KONNEX	Protocol for KNX system	Allows integration with BMS operating with KNX protocol	ALL

OPTIONS

Data Book
NX2-N-G06 0344 - 0808_202105_EN R454B

OPTIONS	DESCRIPTIONS	BENEFITS	AVAILABLE FOR MODELS
4187 M-Net W3000 INTERFACE KIT	Interface kit for M-Net protocol.	Interface module to allow the integration of the unit with Mitsubishi Electric proprietary communication protocol M-Net.	ALL
4188 SERIAL CARD MODBUS TCP/IP	Interface module for ModBus TCP/IP protocol	Allows integration with BMS operating with ModBus TCP/IP protocol.	ALL
4189 SERIAL CARD SNMP	Interface module for SNMP protocol	Allows integration with BMS operating with SNMP protocol.	ALL
6160 AUXILIARY INPUT			
6161 AUXILIARY SIGNAL 4-20mA	4-20 mA analog input	Allows to change the operating set-point according to the value of current applied to the analogue input.	ALL
6162 REMOTE SIGNAL DOUBLE SP	Allows to activate the Energy Saving set-point.	Allows to change the operating set-point according to a remote switch	ALL
6170 DEMAND LIMIT			
6171 INPUT REMOTE DEMAND LIMIT	Digital input (voltage free)	It permits to limit the unit's power absorption for safety reasons or in temporary situation.	ALL
1470 MULTIFUNCTION CARD			
1431 NIGHT MODE	The option includes a related controller expansion board and dedicated terminal block.	Night mode is a system setting to limit maximum noise level of the unit. Noise level is reduced limiting maximum compressor frequency and fan speed.	ALL
1471 4951 + 1431	The option includes a related controller expansion board and dedicated terminal block.	Enables the functions corresponding to the indicated accessory codes.	ALL
1472 4951 + 1431 + 4961	The option includes a related controller expansion board and dedicated terminal block (it is necessary to install a 3 way valve).	Enables the functions corresponding to the indicated accessory codes.	ALL
1473 4951 + 4961	The option includes a related controller expansion board and dedicated terminal block (it is necessary to install a 3 way valve).	Enables the functions corresponding to the indicated accessory codes.	ALL
1474 1431 + 4961	The option includes a related controller expansion board and dedicated terminal block (it is necessary to install a 3 way valve).	Enables the functions corresponding to the indicated accessory codes.	ALL
1475 4962 + 4951	The option includes a related controller expansion board and dedicated terminal block (it is necessary to install a 3 way valve).	Enables the functions corresponding to the indicated accessory codes.	ALL
1476 4962 + 1431	The option includes a related controller expansion board and dedicated terminal block (it is necessary to install a 3 way valve).	Enables the functions corresponding to the indicated accessory codes.	ALL
1477 4962 + 4951 + 1431	The option includes a related controller expansion board and dedicated terminal block (it is necessary to install a 3 way valve).	Enables the functions corresponding to the indicated accessory codes.	ALL

OPTIONS**Data Book**

NX2-N-G06 0344 - 0808_202105_EN R454B

OPTIONS	DESCRIPTIONS	BENEFITS	AVAILABLE FOR MODELS
4951 WITH HYDRAULIC DECOUPLER PROBE	Water temperature probe on hydraulic decoupler.	The pump activation can be set by parameter according to the water temperature on buffer tank measuring by the sensor (in the systems with the primary and secondary circuits separated by a hydraulic decoupler), thus bringing significant pump consumption reduction during unit's stand-by.	ALL
4961 U.L.C.F. - WITH OR WITHOUT FIX SPEED PUMP	Option to be selected with the unit without pump/s or with fix speed pump/s (4703,4706,4707,4711,4712). The option includes a related controller expansion board and dedicated terminal block.	Guaranteed the start-up of the units with the option U.L.C. even when the critical working condition could generate an alarm. The W3000+ controller can manage a 3 way mixing valve (not provided from MEHITS) by 0-10V signal for ensuring a dynamic control of the water temperature on user heat exchanger according to the operating limits allowed. This ensures the start-up and correct functioning of the unit into the envelope, also even critical whether condition.	ALL
4962 U.L.C.F. - WITH VARIABLE WATER FLOW	Option to be selected with the unit with variable speed pump/s (4713,4714,4717,4718,4722,4723). The option includes a related controller expansion board and dedicated terminal block.	Guaranteed the start-up of the units with the option U.L.C. even when the critical working condition could generate an alarm. The W3000+ controller can manage a 3 way mixing valve (not provided from MEHITS) by 0-10V signal for ensuring a dynamic control of the water temperature on user heat exchanger according to the operating limits allowed. This ensures the start-up and correct functioning of the unit into the envelope, also even critical whether condition.	ALL
1510 SOFT-STARTER			
1511 UNIT WITH SOFT-START	Electronic device adopted to manage the inrush current. The device controls 2 phases.	Break down of the inrush current compared to the direct motor start, lower motor windings' mechanical wear, avoidance of mains voltage fluctuations during starting, favourable sizing for the electrical system.	ALL
3300 COMPRESSOR REPHASING			
3301 COMPR.POWER FACTOR CORR.	Capacitors on the compressors' power inlet line.	The unit's average cos(phi) increases.	ALL
1440 USER INTERFACE			
1441 KIPlink + COMPACT KEYBOARD	In addition to KIPlink, the innovative user interface based on WiFi technology, the unit is equipped with the Compact keyboard with LCD display and buttons.		ALL
1442 KIPlink +7 INCH TOUCH SCREEN	In addition to KIPlink, the innovative user interface based on WiFi technology, the unit is equipped with the Touch interface, with a 7" WVGA colour display and a front USB port (WARNING: with outdoor temperature below 0°C the display response time may visibly increase).		ALL

OPTIONS	DESCRIPTIONS	BENEFITS	AVAILABLE FOR MODELS
6192 COMPACT KEYBOARD	Keyboard with LCD display	Features a multi-language menu (with the W3000 software there are 3 languages available). Allows the connection of the remote keyboard. When equipped with a real time clock (optional), enables the alarm history display function.	ALL
6195 7 INCH TOUCH SCREEN	The unit is equipped with the Touch interface, with a 7" WVGA colour display and a front USB port (WARNING: with outdoor temperature below 0°C the display response time may visibly increase).	The touch-screen's technology is characterized by an easy-to-access data, and it allows an effective graphical representation of the main figures protecting the access through 3 privilege levels.	ALL
6196 KIPLink	The unit is equipped with KIPLink, the innovative user interface based on WiFi technology		ALL
6310 VISUAL DISPLAY PROTECTION			
6311 WITH DISPLAY PROTECTION	Display protection sealed panel	Provide complete protection against UV rays, atmospheric agents, sand storms.	ALL
5920 MANAGEMENT & CONTROL SYSTEMS			
5922 ClimaPRO ModBUS RS485 - MID	This option includes the following devices on-board the unit panel: - MID certified network analyzer operating on ModBUS over RS-485 - Current transformers - Software release LA09 or later version.	This accessory allows to acquire the electrical data and the power absorbed by the unit and communicate with ClimaPRO via high level communication interface based on ModBUS over EIA RS-485. More specifically, the data collected are: power supply, current, frequency, power factor (cos), electrical power consumption, energy consumption. This specific energy meter model is MID certified and can therefore be used for billing applications. This option also ensures the compatibility between the units and ClimaPRO, thus allowing ClimaPRO to acquire all the main unit's operating variables and status by means of a high level communication interface to the controller installed onboard the unit panel.	ALL
5923 ClimaPRO BacNET over IP	This option includes the following devices on-board the unit panel: - network analyzer operating on BACnet over IP - Current transformers - Software release LA09 or later version.	This accessory allows to acquire the electrical data and the power absorbed by the unit and communicate with ClimaPRO via high level communication interface based on BACnet over IP. More specifically, the data collected are: power supply, current, frequency, power factor (cos), electrical power consumption, energy consumption. This network analyzer is not MID certified and cannot therefore be used for billing applications. This option also ensures the compatibility between the units and ClimaPRO, thus allowing ClimaPRO to acquire all the main unit's operating variables and status by means of a high level communication interface to the controller installed onboard the unit panel.	ALL

OPTIONS**Data Book****NX2-N-G06 0344 - 0808_202105_EN R454B**

OPTIONS	DESCRIPTIONS	BENEFITS	AVAILABLE FOR MODELS
5924 ENERGY METER FOR BMS	This option includes the following devices on-board the unit panel: - network analyzer with display operating on ModBUS protocol over RS-485 (without certification MID) - current transformers.	This accessory allows to acquire the electrical data and the power absorbed by the unit and send them via RS-485 bus to the BMS for energy metering.	ALL
5925 ENERGY METER FOR W3000	This option includes all following devices on-board the unit panel: - network analyzer with display, already cabled to unit's controller - current transformers.	This option allows to acquire the electrical data and the power absorbed by the unit. The figures are accessible through the unit's W3000 interface, and be sent to the BMS via several protocols by selecting the dedicated serial card in the option list.	ALL
5940 SETP. COMPENSATION OUT. TEMP.			
5941 WITH SETPOINT COMPENSATION	This option includes an outside air sensor to be installed outside the building and enable the climatic curve function.	An outside air temperature probe, available as option, controls the system water temperature set point based on heating and cooling (reversible units) climatic curves. Delivering water at different temperatures to the terminals based on the outside air temperature achieves high seasonal efficiency ratios and provides considerable savings in running costs.	ALL
3390 ANTICONDENSATE HEATER EL.BOARD			
3391 ELECTRIC HEATER ON EL. BOARD	Electrical heater fed directly from the unit, is automatically activated at temperatures internal QE below 30 ° C (off state at T higher than 40 ° C).	It avoids the risk of humidity condensation on the electrical panel.	ALL
3430 REFRIGERANT LEAK DETECTOR			
3431 REFRIG. LEAK DETECTOR	Refrigerant leak detection system, supplied factory mounted and wired in the electrical board. In case of leak detection it will raise an alarm.	It promptly detects gas leakages	ALL
3433 GAS LEAK CONTACT + COMPR. OFF	Refrigerant leak detection system, supplied factory mounted and wired in the electrical board. In case of leak detection it will raise an alarm and stop the unit.	It promptly detects gas leakages and stops the unit	ALL
1400 HP AND LP GAUGES			
1401 HP AND LP GAUGES	High and low pressure gauges	Allows immediate reading of the pressure values on both low and high pressure circuits	ALL
5040 COMPRESSOR SUCTION AND DISCHARGE VALVE			
5042 COMPRESSOR SUCTION AND DISCHARGE VALVE	Shut-off valve on compressor's suction and discharge circuit.	Simplifies maintenance activities	ALL
1960 PRESSURE RELIEF VALVES			
1961 DUAL RELIEF VALVES WITH SWITCH	Dual relief valve with switch	Allows to unselect a relief valve in order to service the unit avoiding medium or long inoperative periods	ALL

OPTIONS

Data Book
NX2-N-G06 0344 - 0808_202105_EN R454B

OPTIONS	DESCRIPTIONS	BENEFITS	AVAILABLE FOR MODELS
890 CONDENSING COIL			
894 Cu PIPES/PREPAINTED ALL. FINIS	Finned coil heat exchanger made from copper tubes and aluminum fins with chemical cleaning treatment to remove impurities, and then coated with protective paint with the following characteristics: - fins treated with protective polyester resin paint; - over 1000 hours of salt spray protection as per ASTM B117 (fins without cross and protected edges); - excellent resistance to UV rays.	Provide a good resistance against corrosion. For further information please refer to the Guidelines "Finned coil heat exchangers and protection against corrosion", available in the download section of the website www.melcohit.com/EN/Download/Corporate/GUIDELINES or contact our sales department.	ALL
895 FIN GUARD SILVER TREATM	Copper-aluminum heat exchanger coils with polyurethane paint Fin Guard Silver SB. Coil completely coated by a protective layer of polyurethane paint with the following characteristics: - polyurethane paint with metallic emulsion; - over 3000 hours of salt spray protection as per ASTM B117; - excellent resistance to UV rays; - high-pressure spray painting system.	Provides a very high resistance against corrosion, also in very aggressive environments. For further information please refer to the Guidelines "Finned coil heat exchangers and protection against corrosion", available in the download section of the website www.melcohit.com/EN/Download/Corporate/GUIDELINES or contact our sales department.	ALL
1260 DRAIN TRAY			
1261 DRAIN TRAY HEATED	The option includes the drain tray equipped with an antifreeze electric heater.	This option collects condensation and avoids the water freezing with a outdoor air temperature close to 0°C or lower.	ALL
820 FAN CONTROL			
802 VAR.FAN SPEED LOW AMB.CONTROL	Fan speed control according to the condensing pressure; the use of this device is mandatory in case the unit operates with low evaporator leaving water temperature combined with low outdoor air temperatures	Extension of the unit operating range (see the section dedicated to the operating limits). The device allows the unit to operate in the most extreme conditions avoiding any risk of low pressure alarm intervention. The enhanced air flow management delivers also benefits in terms of both efficiency and quietness.	ALL
808 EC FANS	Electronically commutated fans (EC fans). The brushless motor, governed by a special controller, continuously adjust fans' speed.	Reduced energy consumption and minimized current's absorption during start-up phase with a connected increased efficiency. The noise reduces proportionally to the unit's partialization.	ALL
4730 U - HYDRONIC MODULE			
4736 U - 1 PUMP 2P LH (FIX SPEED)	User side heat exchanger hydronic module, compatible with constant flow control. The unit is provided with 1 fixed speed pump, with 2-pole motor. Residual head of 100 kPa approximately. Specifications and characteristic curves are available in the dedicated bulletin section.	The hydronic module includes the pumps and the main water circuit components, thus optimizing hydraulic and electrical installation space, time and costs.	ALL
4737 U - 1 PUMP 2P HH (FIX SPEED)	User side heat exchanger hydronic module, compatible with constant flow control. The unit is provided with 1 fixed speed pump, with 2-pole motor. Residual head of 200 kPa approximately. Specifications and characteristic curves are available in the dedicated bulletin section.	The hydronic module includes the pumps and the main water circuit components, thus optimizing hydraulic and electrical installation space, time and costs.	ALL

OPTIONS

Data Book

NX2-N-G06 0344 - 0808_202105_EN R454B

OPTIONS	DESCRIPTIONS	BENEFITS	AVAILABLE FOR MODELS
4741 U - 2 PUMPS 2P LH (FIX SPEED)	User side heat exchanger hydronic module, compatible with constant flow control. The unit is provided with 2 fixed speed pumps, with 2-pole motor. Residual head of 100 kPa approximately. The pumps are controlled in duty/standby, with running hours equalization and changeover on device failure. Specifications and characteristic curves are available in the dedicated bulletin section.	The hydronic module includes the pumps and the main water circuit components, thus optimizing hydraulic and electrical installation space, time and costs.	ALL
4742 U - 2 PUMPS 2P HH (FIX SPEED)	User side heat exchanger hydronic module, compatible with constant flow control. The unit is provided with 2 fixed speed pumps, with 2-pole motor. Residual head of 200 kPa approximately. The pumps are controlled in duty/standby, with running hours equalization and changeover on device failure. Specifications and characteristic curves are available in the dedicated bulletin section.	The hydronic module includes the pumps and the main water circuit components, thus optimizing hydraulic and electrical installation space, time and costs.	ALL
4743 U - RELAY 1 PUMP + 0-10V SIG	User side heat exchanger hydronic module, compatible with constant or variable flow control. The unit is provided with 1 relay and a 0-10V signal terminal to control the activation and the speed of 1 external variable speed pump.	The hydronic module controls the external pumps with the unit controller logic.	ALL
4744 U - RELAY 2 PUMPS + 0-10V SIG	User side heat exchanger hydronic module, compatible with constant or variable flow control. The unit is provided with 2 relays and a 0-10V signal terminal to control the activation and the speed of 2 external variable speed pump. The pumps are controlled in duty/standby, with running hours equalization and changeover on device failure.	The hydronic module controls the external pumps with the unit controller logic.	ALL
4747 U - 1 PUMP 2P LH (VAR SPEED)	User side heat exchanger hydronic module, compatible with constant or variable flow control. The unit is provided with 1 variable speed pump, with 2-pole motor. Residual head of 100 kPa approximately. Specifications and characteristic curves are available in the dedicated bulletin section.	The hydronic module includes the pumps and the main water circuit components, thus optimizing hydraulic and electrical installation space, time and costs.	ALL
4748 U - 1 PUMP 2P HH (VAR SPEED)	User side heat exchanger hydronic module, compatible with constant or variable flow control. The unit is provided with 1 variable speed pump, with 2-pole motor. Residual head of 200 kPa approximately. Specifications and characteristic curves are available in the dedicated bulletin section.	The hydronic module includes the pumps and the main water circuit components, thus optimizing hydraulic and electrical installation space, time and costs.	ALL

OPTIONS

Data Book

NX2-N-G06 0344 - 0808_202105_EN R454B

OPTIONS	DESCRIPTIONS	BENEFITS	AVAILABLE FOR MODELS
4752 U - 2 PUMPS 2P LH (VAR SPEED)	User side heat exchanger hydronic module, compatible with constant or variable flow control. The unit is provided with 2 variable speed pumps, with 2-pole motor. Residual head of 100 kPa approximately. The pumps are controlled in duty/standby, with running hours equalization and changeover on device failure. Specifications and characteristic curves are available in the dedicated bulletin section.	The hydronic module includes the pumps and the main water circuit components, thus optimizing hydraulic and electrical installation space, time and costs.	ALL
4753 U - 2 PUMPS 2P HH (VAR SPEED)	User side heat exchanger hydronic module, compatible with constant or variable flow control. The unit is provided with 2 variable speed pumps, with 2-pole motor. Residual head of 200 kPa approximately. The pumps are controlled in duty/standby, with running hours equalization and changeover on device failure. Specifications and characteristic curves are available in the dedicated bulletin section.	The hydronic module includes the pumps and the main water circuit components, thus optimizing hydraulic and electrical installation space, time and costs.	ALL
4870 U - PRIMARY FLOW CONTROL			
4871 U - CONSTANT FLOW	User side heat exchanger water flow control (plant primary circuit): constant flow. Compatible with hydronic modules without regulation devices (no pumps, no contacts), with ON/OFF regulation devices (relays) or with fixed speed pumps (codes: 4731, 4732, 4733, 4734, 4735, 4736, 4737, 4738, 4739, 4741, 4742 - hydronic modules availability depends on unit model).	The unit is set up to operate with a constant water flow in the heat exchanger (plant primary circuit). This is the only option available in case of unit without any water flow regulation devices (no pumps, no contacts), which means with water flow control provided by others. In case of unit with ON/FF regulation devices or fixed speed pumps, the unit controller manages the pump activation to reduce pump consumption.	ALL
4872 U - CONSTANT FLOW (PARAMETER)	User side heat exchanger water flow control (plant primary circuit): constant flow (parameter set). Compatible with hydronic modules with modulating regulation devices (0-10V signal) or with variable speed pumps (codes: 4743, 4744, 4745, 4746, 4747, 4748, 4749, 4751, 4752, 4753 - hydronic modules availability depends on unit model).	The unit is set up to operate with a constant water flow in the heat exchanger (plant primary circuit). The unit controller manages the pump activation to reduce pump consumption. The pump speed is adjusted via 0-10V signal. The option provides the possibility to set the pump speed with a controller parameter. Once set, the speed pump remains constant until the next parameter adjustment. The parameter set constant flow control is useful during the unit installation and commissioning, to adjust water flow and pressure head according to the real plant characteristics.	ALL

OPTIONS

Data Book

NX2-N-G06 0344 - 0808_202105_EN R454B

OPTIONS	DESCRIPTIONS	BENEFITS	AVAILABLE FOR MODELS
4874 U - VPF (plant DP trans excl)	<p>User side heat exchanger water flow control (plant primary circuit): variable flow (delta P control). Only for single unit systems.</p> <p>Compatible with hydronic modules with modulating regulation devices (0-10V signal) or with variable speed pumps (codes: 4743, 4744, 4745, 4746, 4747, 4748, 4749, 4751, 4752, 4753 - hydronic modules availability depends on unit model).</p> <p>The option includes: differential pressure transducer on the unit's heat exchanger and related controller expansion board, controller expansion board to read the plant side differential pressure transducer (4-20mA signal) and manage the hydraulic by-pass valve opening (0-10V signal).</p> <p>Compulsory equipment, supplied by others: plant side differential pressure transducer, plant side hydraulic by-pass valve.</p>	<p>The unit is set up to operate with a variable water flow in the heat exchanger (plant primary circuit). The unit controller manages the pump activation to reduce pump consumption. The pump speed is adjusted via 0-10V signal.</p> <p>The option provides a pump speed management based on the VPF (Variable Primary Flow) function. It keeps the delta P constant on the plant side (primary circuit), thus bringing significant pump consumption reduction during part load operation. The VPF function is applicable in systems with only the primary circuit. Further information available in the dedicated bulletin section.</p>	ALL
4875 U - VPF (plant DP trans incl)	<p>User side heat exchanger water flow control (plant primary circuit): variable flow (delta P control). Only for single unit systems.</p> <p>Compatible with hydronic modules with modulating regulation devices (0-10V signal) or with variable speed pumps (codes: 4743, 4744, 4745, 4746, 4747, 4748, 4749, 4751, 4752, 4753 - hydronic modules availability depends on unit model).</p> <p>The option includes: differential pressure transducer on the unit's heat exchanger and related controller expansion board, plant side differential pressure transducer (installation by others), controller expansion board to read the plant side differential pressure transducer (4-20mA signal) and manage the hydraulic by-pass valve opening (0-10V signal).</p> <p>Compulsory equipment, supplied by others: plant side hydraulic by-pass valve.</p>	<p>The unit is set up to operate with a variable water flow in the heat exchanger (plant primary circuit). The unit controller manages the pump activation to reduce pump consumption. The pump speed is adjusted via 0-10V signal.</p> <p>The option provides a pump speed management based on the VPF (Variable Primary Flow) function. It keeps the delta P constant on the plant side (primary circuit), thus bringing significant pump consumption reduction during part load operation. The VPF function is applicable in systems with only the primary circuit. Further information available in the dedicated bulletin section.</p>	ALL
4876 U - VPF MULTI-UNIT SYSTEM	<p>User side heat exchanger water flow control (plant primary circuit): variable flow (delta P control). Only for multi-unit systems.</p> <p>Compatible with hydronic modules with modulating regulation devices (0-10V signal) or with variable speed pumps (codes: 4743, 4744, 4745, 4746, 4747, 4748, 4749, 4751, 4752, 4753 - hydronic modules availability depends on unit model).</p> <p>The option includes: differential pressure transducer on the unit's heat exchanger and related controller expansion board.</p> <p>It shall be the customer responsibility to configure the multi-unit control system (Manager3000 or KlimaPRO) with option VPF.</p>	<p>The unit is set up to operate with a variable water flow in the heat exchanger (plant primary circuit). The unit controller manages the pump activation to reduce pump consumption. The pump speed is adjusted via 0-10V signal.</p> <p>The option provides a pump speed management based on the VPF (Variable Primary Flow) function. It keeps the delta P constant on the plant side (primary circuit), thus bringing significant pump consumption reduction during part load operation. The VPF function is applicable in systems with only the primary circuit. Further information available in the dedicated bulletin section.</p>	ALL

OPTIONS	DESCRIPTIONS	BENEFITS	AVAILABLE FOR MODELS
<p>4877 U - VPF.D</p>	<p>User side heat exchanger water flow control (plant primary circuit): variable flow (delta T control). Only for single unit systems. Compatible with hydronic modules with modulating regulation devices (0-10V signal) or with variable speed pumps (codes: 4743, 4744, 4745, 4746, 4747, 4748, 4749, 4751, 4752, 4753 - hydronic modules availability depends on unit model). The option includes: 2 plant side NTC temperature sensors (installation by others).</p>	<p>The unit is set up to operate with a variable water flow in the heat exchanger (plant primary circuit). The unit controller manages the pump activation to reduce pump consumption. The pump speed is adjusted via 0-10V signal. The option provides a pump speed management based on the VPF.D (Variable Primary Flow with Decoupler) function. It keeps the delta T constant on the plant side (primary circuit), thus bringing significant pump consumption reduction during part load operation. The VPF.D function is applicable in systems with the primary and secondary circuits separated by a hydraulic decoupler. Further information available in the dedicated bulletin section.</p>	<p>ALL</p>
<p>4878 U - VPF.D MULTI-UNIT SYSTEM</p>	<p>User side heat exchanger water flow control (plant primary circuit): variable flow (delta T control). Only for multi-unit systems. Compatible with hydronic modules with modulating regulation devices (0-10V signal) or with variable speed pumps (codes: 4743, 4744, 4745, 4746, 4747, 4748, 4749, 4751, 4752, 4753 - hydronic modules availability depends on unit model). It shall be the customer responsibility to configure the multi-unit control system (Manager3000 or ClimaPRO) with option VPF.D.</p>	<p>The unit is set up to operate with a variable water flow in the heat exchanger (plant primary circuit). The unit controller manages the pump activation to reduce pump consumption. The pump speed is adjusted via 0-10V signal. The option provides a pump speed management based on the VPF.D (Variable Primary Flow with Decoupler) function. It keeps the delta T constant on the plant side (primary circuit), thus bringing significant pump consumption reduction during part load operation. The VPF.D function is applicable in systems with the primary and secondary circuits separated by a hydraulic decoupler. Further information available in the dedicated bulletin section.</p>	<p>ALL</p>
<p>4879 U - VPF.E</p>	<p>User side heat exchanger water flow control (plant primary circuit): variable flow (delta T control). Compatible with hydronic modules with modulating regulation devices (0-10V signal) or with variable speed pumps (codes: 4743, 4744, 4745, 4746, 4747, 4748, 4749, 4751, 4752, 4753 - hydronic modules availability depends on unit model).</p>	<p>The unit is set up to operate with a variable water flow in the heat exchanger (plant primary circuit). The unit controller manages the pump activation to reduce pump consumption. The pump speed is adjusted via 0-10V signal. The option provides a pump speed management based on the VPF.E function. It keeps the delta T constant on the plant side (primary circuit), thus bringing significant pump consumption reduction during part load operation. The VPF.E function is applicable in systems with only the primary circuit and with the hydraulic terminals equipped 3 way valve (by-pass). Further information available in the dedicated bulletin section.</p>	<p>ALL</p>
<p>4940 BUFFER TANK</p>			
<p>4942 U - WITH BUFFER TANK</p>	<p>Buffer tank covered by a 20 mm thick of insulation lining in closed-cell reticulated foam, which capacity depends on the unit size (see the dedicated table). In the dedicated section are described all the factory-mounted components included in the buffer tank system.</p>	<p>It helps to reach the plant water content required for the correct unit operation (see dedicated section "Hydraulic Data").</p>	<p>ALL</p>

OPTIONS

Data Book
NX2-N-G06 0344 - 0808_202105_EN R454B

OPTIONS	DESCRIPTIONS	BENEFITS	AVAILABLE FOR MODELS
2420 TANK ANTIFREEZE HEATER			
2421 TANK ANTIFREEZE HEATER			ALL
2020 ANTI-INTRUSION GRILLS			
2021 ANTI-INTRUSION GRILLS	Anti-intrusions grills	Avoid the intrusion of solid bodies into the unit's structure.	ALL
2290 UNIT ENCLOSURE			
2311 UNIT WITH ENCLOSURE	Compressor enclosure and pump group enclosure (if present)	Protects the main components of the unit	ALL
2312 UNIT WITH ACOUSTICAL ENCLOSURE	Compressor enclosure with soundproofing insulation in polyester fiber mat (thickness of 30 mm on sides and on top, 15 mm on bottom) If the hydronic is present, the pump enclosure is acoustically insulated: 15 mm thick Fiberform (polyester fibres)	Protects the main components of the unit and reduces the noise emissions	ALL
1980 ENCLOSURE PANELS			
1981 SIDE PANELS ON THE COILS	Metallic panels on the side of the coils that cover piping and headers.	Improve protection and aesthetics.	ALL
1970 LONG DISTANCE TRANSPORTATION			
1971 REINFORCING BARS	Bars used to reinforce the structure	Improve resistance during long transportation	ALL
9970 PACKING			
9971 WITHOUT PACKAGING	Unit provided with plastic supports		ALL
9972 WOODEN BOX PACKING	Unit provided with wooden box		ALL
9973 WOODEN CAGE PACKING	Unit provided with wooden cage		ALL
9974 MARINE PACKING	Unit provided with barrier bag and wooden cage		ALL
9979 CONTAINER PACKING	Unit provided with container slides and covered with nylon		ALL
9996 CONTAINER SLIDES	Unit provided with container slides		ALL
9999 SUPPORTS AND NYLON	Unit provided with plastic supports and covered with nylon		ALL
AC01 ACCESSOR. SUPPLIED SEPARATELY			
AC01 EVAPORATOR WATER FLOWSWITCH	Flow switch with stainless scoop AISI 316L and IP65 protection suitable for installation in industrial plant pipes. It should be installed in a straight pipe without filters, valves, etc., long at least 5 times its diameter, both upstream and downstream.	Signaling of lack of or excessive reduction of flow, it generates an alarm that is in automatic or manual reset depending on n ° alarms per hour and the maximum time of operation of the pump under conditions of low flow rate.	ALL

OPTIONS**Data Book**
NX2-N-G06 0344 - 0808_202105_EN R454B

OPTIONS	DESCRIPTIONS	BENEFITS	AVAILABLE FOR MODELS
AC05 SPRING TYPE ANTIVIBR.MOUNTING			ALL

5.2 Options - Additional information

1015 – Heat exchangers NSW certified

The certification is available for the evaporator only. If the certification is required also for the recovery heat exchanger (versions /D), please contact our sales department.

2312 – Unit with acoustical enclosure

Compressor compartment soundproofing insulation characteristics: polyester fiber mat (thickness of 30 mm on sides and on top, 15 mm on bottom). Pump/s soundproofing insulation characteristics: 15 mm thick Fiberform (polyester fibers).
Noise power reduction: -2 dB(A).

3301 – Compressor power factor correction 1511 – Soft starter

There is a mutual exclusion rule between the compressor rephasing condensers and the soft start device. When both accessories are required together, a feasibility analysis is needed. If the configuration is available as a special execution, an extra-price may be quoted.

3431 – Refrigerant leak detector 3433 – Refrigerant leak detector + compressors off

The purpose of these options is to check and raise an alarm whether a leak occurs; they should not be considered as safety devices.

1431 – Night mode

With factory settings, the noise reduction achieved is: -3 dB(A).

2421 – Tank antifreeze heater

The selection of this option is mandatory when the outdoor air temperature is $\leq 0^{\circ}\text{C}$.

1261 – Drain tray heated

The selection of this option is mandatory when the outdoor air temperature is $\leq 0^{\circ}\text{C}$.

- 808 – EC Fans**
- 3301 – Compr. Power factor corr.**
- 2311 – Unit with enclosure**

The simultaneous selection of option 808 - EC fans and option 3301 - Compr. Power factor corr. implies the mandatory inclusion of option 2311 - Unit with enclosure for the following sizes:

Version K: 0344, 0364, 0404, 0446, 0506, 0526, 0546

Version A: 0446

- 808 – EC Fans**
- 9979 – Container packing**
- 9996 – Container slides**

CONTAINER SHIPPING FOR UNITS PROVIDED WITH OPTIONAL EC FANS

The units can be provided with EC fans upon request (option 808). The selection of this option may increase the unit's height.

When the unit is ordered with EC fans and is to be shipped via container (opt. 9979 – Container packing or opt. 9996 – Container slides), a specific procedure before unit start-up must be followed.

This procedure is only for units with 450mm EC fans. The models involved are as follows:

Version K: 0344, 0364, 0404, 0446, 0506, 0526, 0546

Version SL: 0344, 0446, 0506, 0526

Version A: 0446

OPERATING PROCEDURE

- 1) The units are shipped ex factory without stainless steel spacer in the fans, see fig. A.

DURING SHIPMENT

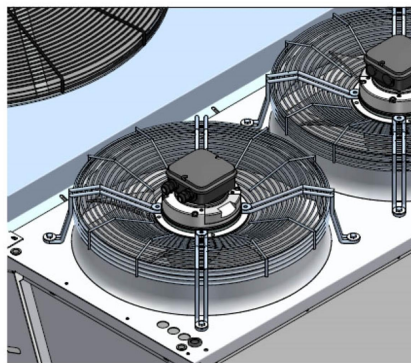

Fig. A

A kit with 4 spacers is provided in the electrical box of the unit for each 450mm diameter EC FAN.

2) Once the unit has been installed on site and before its start-up, the 4 spacers must be installed as in fig. B.

BEFORE STARTING THE UNIT

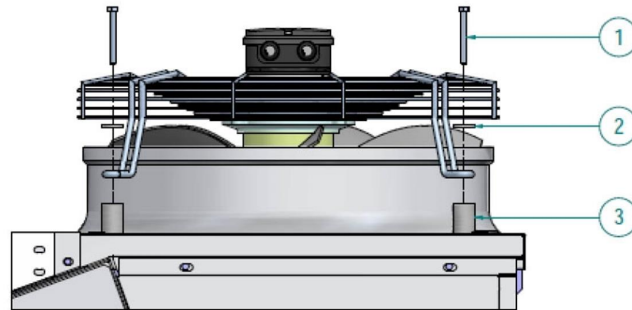

Fig. B

3) Only once the spacers have been installed, can the unit operate properly (fig. C)

DURING OPERATION

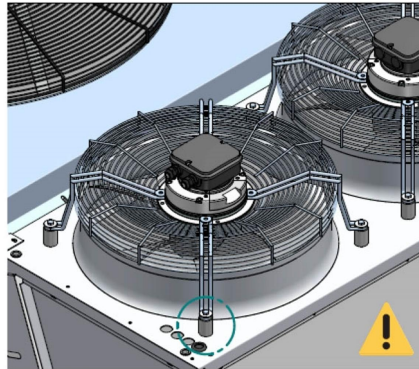

Fig. C

Chiller Plant Control with Active Optimization System

ClimaPRO System Manager

ClimaPRO System Manager represents the state-of-the-art platform for chiller plant management and control.

ClimaPRO ensures to actively optimize the entire chiller plant by managing and adjusting each component directly involved in the production and the distribution of the heating and the cooling energies, therefore involving chillers and heat pumps, pumping groups as well as the source-side devices like, for example, the cooling towers.

In particular, ClimaPRO measures in real-time all the operating variables from the field, for each individual device and each of the main system branches, by using serial communication lines as well as dedicated analogue signals.

The acquired data are then compared with the design data of each single unit at any different working conditions, thus allowing to implement control strategies based on dynamic algorithms which take into account the real operating conditions.

On the basis of these values, an advanced diagnostic module also allows to assess the level of efficiency for each individual unit, translating data into easy-to-read information in order to simplify and optimize the maintenance activities.

The "Chart Builder" software module allows to display the trends of the main operating variables. The "Reporting" module allows to send reports to selected users, including data and system's status of the main devices as well as to perform calculation of the energy indexes for each single unit and for the entire chiller plant.

The accessibility to ClimaPRO System Manager is ensured by an integrated web server that makes it visible from any computer equipped with a web browser, either locally or remotely.



6 GENERAL TECHNICAL DATA

Data Book

NX2-N-G06 0344 - 0808_202105_EN R454B

[SI System]

NX2-N-G06 / K		0344	0364	0404	0446	0506	0526	0546	
Power supply		V/ph/Hz 400/3/50 400/3/50 400/3/50 400/3/50 400/3/50 400/3/50 400/3/50							
PERFORMANCE									
COOLING ONLY (GROSS VALUE)									
Cooling capacity	(1)	kW	334,7	355,0	382,4	430,6	475,7	516,4	533,6
Total power input	(1)	kW	122,8	126,2	141,6	163,0	175,4	183,7	189,4
EER	(1)	kW/kW	2,726	2,813	2,701	2,642	2,712	2,811	2,817
COOLING ONLY (EN14511 VALUE)									
Cooling capacity	(1)(2)	kW	334,3	354,7	382,0	430,2	475,1	515,9	533,1
EER	(1)(2)	kW/kW	2,690	2,780	2,670	2,620	2,680	2,780	2,790
HEATING ONLY (GROSS VALUE)									
Total heating capacity	(3)	kW	364,7	386,5	414,9	469,4	512,7	560,2	579,9
Total power input	(3)	kW	119,3	124,9	134,8	155,5	168,4	181,7	186,9
COP	(3)	kW/kW	3,057	3,094	3,078	3,019	3,045	3,083	3,103
HEATING ONLY (EN14511 VALUE)									
Total heating capacity	(3)(2)	kW	365,2	387,0	415,4	470,0	513,3	560,7	580,5
COP	(3)(2)	kW/kW	3,020	3,060	3,040	2,980	3,000	3,050	3,070
COOLING WITH PARTIAL RECOVERY									
Cooling capacity	(4)	kW	347,3	368,4	396,8	446,8	493,5	535,8	553,7
Total power input	(4)	kW	118,9	122,2	137,1	157,7	169,9	177,9	183,4
Desuperheater heating capacity	(4)	kW	98,87	101,9	115,7	133,0	140,5	147,9	153,0
EXCHANGERS									
HEAT EXCHANGER USER SIDE IN COOLING									
Water flow	(1)	l/s	16,01	16,98	18,29	20,59	22,75	24,70	25,52
Pressure drop at the heat exchanger	(1)	kPa	48,1	38,5	44,7	43,4	53,0	43,5	46,4
HEAT EXCHANGER USER SIDE IN HEATING									
Water flow	(3)	l/s	17,60	18,66	20,03	22,66	24,75	27,04	27,99
Pressure drop at the heat exchanger	(3)	kPa	58,2	46,5	53,5	52,6	62,7	52,1	55,9
PARTIAL RECOVERY USER SIDE IN REFRIGERATION									
Water flow	(4)	l/s	4,773	4,921	5,584	6,418	6,781	7,142	7,386
Pressure drop at the heat exchanger	(4)	kPa	34,5	31,7	40,8	35,8	39,9	32,4	31,8
REFRIGERANT CIRCUIT									
Compressors nr.		N°	4	4	4	6	6	6	6
Number of capacity steps		N°	4	4	4	6	6	6	6
No. Circuits		N°	2	2	2	3	3	3	3
Regulation			STEPS STEPS STEPS STEPS STEPS STEPS STEPS						
Min. capacity step		%	25	25	25	17	17	17	17
Refrigerant			R454B	R454B	R454B	R454B	R454B	R454B	R454B
Refrigerant charge		kg	64,8	68,4	68,4	83,7	87,3	98,1	113
Oil charge		kg	25,0	25,0	25,0	39,0	38,0	38,0	38,0
Rc (ASHRAE)	(5)	kg/kW	0,20	0,19	0,18	0,20	0,19	0,19	0,21
FANS									
Quantity		N°	12	12	12	10	18	18	18
Air flow		m³/s	35,95	34,59	34,59	39,52	53,07	51,13	51,88
Fans power input		kW	2,00	2,00	2,00	2,00	2,00	2,00	2,00
NOISE LEVEL									
Total sound Pressure	(6)	dB(A)	76	76	76	76	76	76	76
Total sound power level in cooling	(7)(8)	dB(A)	96	96	96	96	97	97	97
Total sound power level in heating	(7)(9)	dB(A)	96	96	96	96	97	97	97
SIZE AND WEIGHT									
A	(10)	mm	3905	3905	3905	4515	5690	5690	5690
B	(10)	mm	2260	2260	2260	2260	2260	2260	2260
H	(10)	mm	2450	2450	2450	2450	2450	2450	2450
Operating weight	(10)	kg	3030	3110	3150	4040	4400	4530	4600

Notes:

1 Plant (side) cooling exchanger water (in/out) 12,00°C/7,00°C; Source (side) heat exchanger air (in) 35,0°C.

2 Values in compliance with EN14511

3 Plant (side) heat exchanger water (in/out) 40,00°C/45,00°C; Source (side) heat exchanger air (in) 7,0°C - 87% R.H.

4 Plant (side) cooling exchanger water (in/out) 12,00°C/7,00°C; Source (side) heat exchanger air (in) 35,0°C; Plant (side) heat exchanger recovery water (in/out) 40,00°C/45,00°C.

5 Rated in accordance with AHRI Standard 550/590

6 Average sound pressure level at 1m distance, unit in a free field on a reflective surface; non-binding value calculated from the sound power level.

7 Sound power on the basis of measurements taken in compliance with ISO 9614.

8 Sound power level in cooling, outdoors.

9 Sound power level in heating, outdoors.

10 Unit in standard configuration, without optional accessories.

- Not available

Data certified in EUROVENT

GENERAL TECHNICAL DATA

Data Book

NX2-N-G06 0344 - 0808_202105_EN R454B

[SI System]

NX2-N-G06 / SL		0344	0364	0404	0446	0506	0526	0546	
Power supply		V/ph/Hz 400/3/50 400/3/50 400/3/50 400/3/50 400/3/50 400/3/50 400/3/50							
PERFORMANCE									
COOLING ONLY (GROSS VALUE)									
Cooling capacity	(1)	kW	316,4	336,8	370,6	409,4	444,0	486,6	506,1
Total power input	(1)	kW	128,4	132,8	144,6	170,3	184,7	194,0	199,4
EER	(1)	kW/kW	2,464	2,536	2,563	2,404	2,404	2,508	2,538
COOLING ONLY (EN14511 VALUE)									
Cooling capacity	(1)(2)	kW	316,0	336,4	370,2	409,0	443,6	486,1	505,7
EER	(1)(2)	kW/kW	2,440	2,510	2,540	2,380	2,380	2,490	2,510
HEATING ONLY (GROSS VALUE)									
Total heating capacity	(3)	kW	362,0	379,2	420,1	470,8	511,1	552,0	568,8
Total power input	(3)	kW	114,1	120,5	131,1	150,6	162,1	174,2	180,3
COP	(3)	kW/kW	3,173	3,147	3,204	3,126	3,153	3,169	3,155
HEATING ONLY (EN14511 VALUE)									
Total heating capacity	(3)(2)	kW	362,5	379,6	420,6	471,4	511,7	552,6	569,4
COP	(3)(2)	kW/kW	3,130	3,110	3,160	3,090	3,110	3,130	3,120
COOLING WITH PARTIAL RECOVERY									
Cooling capacity	(4)	kW	328,2	349,4	384,5	424,8	460,7	504,8	525,1
Total power input	(4)	kW	124,2	128,5	139,8	164,6	178,5	187,6	192,8
Desuperheater heating capacity	(4)	kW	108,4	111,4	121,9	144,0	156,8	163,4	167,3
EXCHANGERS									
HEAT EXCHANGER USER SIDE IN COOLING									
Water flow	(1)	l/s	15,13	16,11	17,72	19,58	21,23	23,27	24,20
Pressure drop at the heat exchanger	(1)	kPa	43,0	34,6	41,9	39,2	46,2	38,6	41,8
HEAT EXCHANGER USER SIDE IN HEATING									
Water flow	(3)	l/s	17,47	18,30	20,28	22,73	24,67	26,65	27,46
Pressure drop at the heat exchanger	(3)	kPa	57,4	44,7	54,9	52,9	62,3	50,6	53,7
PARTIAL RECOVERY USER SIDE IN REFRIGERATION									
Water flow	(4)	l/s	5,231	5,378	5,885	6,949	7,569	7,887	8,074
Pressure drop at the heat exchanger	(4)	kPa	41,5	37,9	45,3	41,9	49,7	39,5	38,0
REFRIGERANT CIRCUIT									
Compressors nr.		N°	4	4	4	6	6	6	6
Number of capacity steps		N°	4	4	4	6	6	6	6
No. Circuits		N°	2	2	2	3	3	3	3
Regulation			STEPS STEPS STEPS STEPS STEPS STEPS STEPS						
Min. capacity step		%	25	25	25	17	17	17	17
Refrigerant			R454B	R454B	R454B	R454B	R454B	R454B	R454B
Refrigerant charge		kg	71,9	74,1	85,2	96,3	106	112	113
Oil charge		kg	25,0	25,0	25,0	39,0	38,0	38,0	38,0
Rc (ASHRAE)	(5)	kg/kW	0,23	0,22	0,23	0,24	0,24	0,23	0,23
FANS									
Quantity		N°	10	8	8	18	18	14	12
Air flow		m³/s	27,28	30,33	29,48	35,07	33,16	42,86	45,49
Fans power input		kW	1,00	1,00	1,00	1,00	1,00	1,00	1,00
NOISE LEVEL									
Total sound Pressure	(6)	dB(A)	68	68	68	68	68	69	69
Total sound power level in cooling	(7)(8)	dB(A)	88	88	88	89	89	90	90
Total sound power level in heating	(7)(9)	dB(A)	89	89	89	90	90	91	91
SIZE AND WEIGHT									
A	(10)	mm	4515	5080	5080	5690	5690	6865	7430
B	(10)	mm	2260	2260	2260	2260	2260	2260	2260
H	(10)	mm	2450	2450	2450	2450	2450	2450	2450
Operating weight	(10)	kg	3330	3460	3630	4640	4750	5050	5170

Notes:

1 Plant (side) cooling exchanger water (in/out) 12,00°C/7,00°C; Source (side) heat exchanger air (in) 35,0°C.

2 Values in compliance with EN14511

3 Plant (side) heat exchanger water (in/out) 40,00°C/45,00°C; Source (side) heat exchanger air (in) 7,0°C - 87% R.H.

4 Plant (side) cooling exchanger water (in/out) 12,00°C/7,00°C; Source (side) heat exchanger air (in) 35,0°C; Plant (side) heat exchanger recovery water (in/out) 40,00°C/45,00°C.

5 Rated in accordance with AHRI Standard 550/590

6 Average sound pressure level at 1m distance, unit in a free field on a reflective surface; non-binding value calculated from the sound power level.

7 Sound power on the basis of measurements taken in compliance with ISO 9614.

8 Sound power level in cooling, outdoors.

9 Sound power level in heating, outdoors.

10 Unit in standard configuration, without optional accessories.

- Not available

Data certified in EUROVENT

GENERAL TECHNICAL DATA

Data Book

NX2-N-G06 0344 - 0808_202105_EN R454B

[SI System]

NX2-N-G06 / A		0344	0364	0404	0446	0506	0526	0546	0606	0708	0738	
Power supply		V/ph/Hz 400/3/50 400/3/50 400/3/50 400/3/50 400/3/50 400/3/50 400/3/50 400/3/50 400/3/50 400/3/50 400/3/50										
PERFORMANCE												
COOLING ONLY (GROSS VALUE)												
Cooling capacity	(1)	kW	345,3	361,5	399,8	446,5	500,0	525,8	543,5	599,3	696,6	724,8
Total power input	(1)	kW	116,8	121,4	133,4	152,0	168,8	177,0	182,1	196,5	228,7	238,0
EER	(1)	kW/kW	2,956	2,978	2,997	2,938	2,962	2,971	2,985	3,050	3,046	3,045
COOLING ONLY (EN14511 VALUE)												
Cooling capacity	(1)(2)	kW	344,9	361,1	399,3	446,0	499,5	525,3	543,0	598,8	696,0	724,2
EER	(1)(2)	kW/kW	2,920	2,950	2,960	2,900	2,920	2,940	2,950	3,010	3,010	3,010
HEATING ONLY (GROSS VALUE)												
Total heating capacity	(3)	kW	376,3	397,2	426,7	492,5	531,0	573,6	596,0	640,0	752,7	794,7
Total power input	(3)	kW	116,4	123,0	131,8	153,1	164,1	177,1	184,0	193,6	227,6	239,7
COP	(3)	kW/kW	3,233	3,229	3,237	3,217	3,236	3,239	3,239	3,306	3,307	3,315
HEATING ONLY (EN14511 VALUE)												
Total heating capacity	(3)(2)	kW	376,8	397,7	427,2	493,1	531,6	574,2	596,6	640,6	753,4	795,3
COP	(3)(2)	kW/kW	3,190	3,190	3,200	3,170	3,190	3,200	3,200	3,260	3,260	3,280
COOLING WITH PARTIAL RECOVERY												
Cooling capacity	(4)	kW	358,3	375,1	414,8	463,3	518,8	545,5	563,9	621,8	722,7	751,9
Total power input	(4)	kW	113,3	117,7	129,3	147,4	163,7	171,6	176,6	190,3	221,7	230,7
Desuperheater heating capacity	(4)	kW	89,98	94,05	104,8	117,8	129,2	136,5	141,2	157,2	179,9	188,2
EXCHANGERS												
HEAT EXCHANGER USER SIDE IN COOLING												
Water flow	(1)	l/s	16,51	17,29	19,12	21,35	23,91	25,14	25,99	28,66	33,31	34,66
Pressure drop at the heat exchanger	(1)	kPa	51,2	39,9	48,8	46,7	58,5	45,1	48,2	51,1	50,3	40,5
HEAT EXCHANGER USER SIDE IN HEATING												
Water flow	(3)	l/s	18,17	19,17	20,60	23,77	25,63	27,69	28,77	30,89	36,34	38,36
Pressure drop at the heat exchanger	(3)	kPa	62,0	49,1	56,6	57,9	67,3	54,6	59,0	59,4	59,9	49,6
PARTIAL RECOVERY USER SIDE IN REFRIGERATION												
Water flow	(4)	l/s	4,343	4,540	5,058	5,688	6,238	6,591	6,813	7,586	8,684	9,085
Pressure drop at the heat exchanger	(4)	kPa	28,6	27,0	33,5	28,1	33,8	27,6	27,1	33,6	32,3	31,0
REFRIGERANT CIRCUIT												
Compressors nr.		N°	4	4	4	6	6	6	6	6	8	8
Number of capacity steps		N°	4	4	4	6	6	6	6	6	8	8
No. Circuits		N°	2	2	2	3	3	3	3	3	4	4
Regulation			STEPS	STEPS	STEPS	STEPS	STEPS	STEPS	STEPS	STEPS	STEPS	STEPS
Min. capacity step		%	25	25	25	17	17	17	17	17	12,5	12,5
Refrigerant			R454B	R454B	R454B	R454B	R454B	R454B	R454B	R454B	R454B	R454B
Refrigerant charge		kg	81,0	86,4	86,9	109	112	124	133	133	162	173
Oil charge		kg	25,0	25,0	25,0	39,0	38,0	38,0	38,0	38,0	50,0	50,0
Rc (ASHRAE)	(5)	kg/kW	0,24	0,24	0,22	0,25	0,23	0,24	0,25	0,22	0,23	0,24
FANS												
Quantity		N°	8	8	8	16	12	12	12	12	16	16
Air flow		m³/s	47,93	46,12	46,12	56,58	70,76	68,18	69,18	69,18	95,87	92,24
Fans power input		kW	2,00	2,00	2,00	2,00	2,00	2,00	2,00	1,70	1,70	1,70
NOISE LEVEL												
Total sound Pressure	(6)	dB(A)	77	77	77	76	77	77	77	78	77	78
Total sound power level in cooling	(7)(8)	dB(A)	97	97	97	97	98	98	98	99	99	100
Total sound power level in heating	(7)(9)	dB(A)	97	97	97	97	98	98	98	0	0	0
SIZE AND WEIGHT												
A	(10)	mm	5080	5080	5080	6255	7430	7430	7430	7430	9780	9780
B	(10)	mm	2260	2260	2260	2260	2260	2260	2260	2260	2260	2260
H	(10)	mm	2450	2450	2450	2450	2450	2450	2450	2450	2450	2450
Operating weight	(10)	kg	3350	3440	3480	4650	4900	5060	5140	5200	6580	6760

Notes:

1 Plant (side) cooling exchanger water (in/out) 12,00°C/7,00°C; Source (side) heat exchanger air (in) 35,0°C.

2 Values in compliance with EN14511

3 Plant (side) heat exchanger water (in/out) 40,00°C/45,00°C; Source (side) heat exchanger air (in) 7,0°C - 87% R.H.

4 Plant (side) cooling exchanger water (in/out) 12,00°C/7,00°C; Source (side) heat exchanger air (in) 35,0°C; Plant (side) heat exchanger recovery water (in/out) 40,00°C/45,00°C.

5 Rated in accordance with AHRI Standard 550/590

6 Average sound pressure level at 1m distance, unit in a free field on a reflective surface; non-binding value calculated from the sound power level.

7 Sound power on the basis of measurements taken in compliance with ISO 9614.

8 Sound power level in cooling, outdoors.

9 Sound power level in heating, outdoors.

10 Unit in standard configuration, without optional accessories.

- Not available

Data certified in EUROVENT

GENERAL TECHNICAL DATA

Data Book
NX2-N-G06 0344 - 0808_202105_EN R454B

[SI System]

NX2-N-G06 / A		0768	0808
Power supply		V/ph/Hz	400/3/50 400/3/50
PERFORMANCE			
COOLING ONLY (GROSS VALUE)			
Cooling capacity	(1)	kW	762,0 799,2
Total power input	(1)	kW	248,8 262,0
EER	(1)	kW/kW	3,063 3,050
COOLING ONLY (EN14511 VALUE)			
Cooling capacity	(1)(2)	kW	761,4 798,6
EER	(1)(2)	kW/kW	3,030 3,020
HEATING ONLY (GROSS VALUE)			
Total heating capacity	(3)	kW	825,4 853,3
Total power input	(3)	kW	250,1 258,1
COP	(3)	kW/kW	3,300 3,306
HEATING ONLY (EN14511 VALUE)			
Total heating capacity	(3)(2)	kW	826,0 854,1
COP	(3)(2)	kW/kW	3,260 3,260
COOLING WITH PARTIAL RECOVERY			
Cooling capacity	(4)	kW	790,6 829,2
Total power input	(4)	kW	241,0 253,7
Desuperheater heating capacity	(4)	kW	197,8 209,6
EXCHANGERS			
HEAT EXCHANGER USER SIDE IN COOLING			
Water flow	(1)	l/s	36,44 38,22
Pressure drop at the heat exchanger	(1)	kPa	44,7 49,2
HEAT EXCHANGER USER SIDE IN HEATING			
Water flow	(3)	l/s	39,84 41,19
Pressure drop at the heat exchanger	(3)	kPa	53,5 57,2
PARTIAL RECOVERY USER SIDE IN REFRIGERATION			
Water flow	(4)	l/s	9,548 10,12
Pressure drop at the heat exchanger	(4)	kPa	34,3 38,5
REFRIGERANT CIRCUIT			
Compressors nr.		N°	8 8
Number of capacity steps		N°	8 8
No. Circuits		N°	4 4
Regulation		STEPS	STEPS
Min. capacity step		%	12,5 12,5
Refrigerant			R454B R454B
Refrigerant charge		kg	174 176
Oil charge		kg	50,0 50,0
Rc (ASHRAE)	(5)	kg/kW	0,23 0,22
FANS			
Quantity		N°	16 16
Air flow		m³/s	92,24 92,24
Fans power input		kW	1,70 1,70
NOISE LEVEL			
Total sound Pressure	(6)	dB(A)	78 78
Total sound power level in cooling	(7)(8)	dB(A)	100 100
Total sound power level in heating	(7)(9)	dB(A)	0 0
SIZE AND WEIGHT			
A	(10)	mm	9780 9780
B	(10)	mm	2260 2260
H	(10)	mm	2450 2450
Operating weight	(10)	kg	6800 6840

Notes:

- Plant (side) cooling exchanger water (in/out) 12,00°C/7,00°C; Source (side) heat exchanger air (in) 35,0°C.
- Values in compliance with EN14511
- Plant (side) heat exchanger water (in/out) 40,00°C/45,00°C; Source (side) heat exchanger air (in) 7,0°C - 87% R.H.
- Plant (side) cooling exchanger water (in/out) 12,00°C/7,00°C; Source (side) heat exchanger air (in) 35,0°C; Plant (side) heat exchanger recovery water (in/out) 40,00°C/45,00°C.
- Rated in accordance with AHRI Standard 550/590
- Average sound pressure level at 1m distance, unit in a free field on a reflective surface; non-binding value calculated from the sound power level.
- Sound power on the basis of measurements taken in compliance with ISO 9614.
- Sound power level in cooling, outdoors.
- Sound power level in heating, outdoors.
- Unit in standard configuration, without optional accessories.
- Not available

Data certified in EUROVENT

7 TECHNICAL DATA SEASONAL EFFICIENCY IN HEATING (EN14825 VALUE)

Data Book

NX2-N-G06 0344 - 0808_202105_EN R454B

[SI System]

NX2-N-G06 / K - LOW TEMPERATURE application			0344	0364	0404	0446	0506	0526
Power supply		(V/ph/Hz)	400/3/50	400/3/50	400/3/50	400/3/50	400/3/50	400/3/50
WEATHER CONDITIONS - AVERAGE								
Rated heat output at Tdesignh	(1)(2)	kW	268	294	323	369	388	363
Bivalent temperature	(1)(2)	°C	-7	-7	-7	-7	-7	-10
SCOP	(1)(2)		3,60	3,70	3,73	3,66	3,53	3,49
Seasonal space heating energy efficiency	(1)(2)	%	141	145	146	143	138	137
Seasonal space heating energy efficiency class	(1)(2)		-	-	-	-	-	-

1 Seasonal space heating energy efficiency class LOW TEMPERATURE [REGULATION (EU) N. 813/2013]

2 Tipo di calcolo con portata variabile e temperatura variabile.

NX2-N-G06 / K - LOW TEMPERATURE application			0546
Power supply		(V/ph/Hz)	400/3/50
WEATHER CONDITIONS - AVERAGE			
Rated heat output at Tdesignh	(1)(2)	kW	373
Bivalent temperature	(1)(2)	°C	-10
SCOP	(1)(2)		3,53
Seasonal space heating energy efficiency	(1)(2)	%	138
Seasonal space heating energy efficiency class	(1)(2)		-

1 Seasonal space heating energy efficiency class LOW TEMPERATURE [REGULATION (EU) N. 813/2013]

2 Tipo di calcolo con portata variabile e temperatura variabile.

TECHNICAL DATA SEASONAL EFFICIENCY IN HEATING (EN14825 VALUE)

Data Book

NX2-N-G06 0344 - 0808_202105_EN R454B

[SI System]

NX2-N-G06 / SL - LOW TEMPERATURE application			0344	0364	0404	0446	0506	0526
Power supply		(V/ph/Hz)	400/3/50	400/3/50	400/3/50	400/3/50	400/3/50	400/3/50
WEATHER CONDITIONS - AVERAGE								
Rated heat output at Tdesignh	(1)(2)	kW	227	252	319	294	390	356
Bivalent temperature	(1)(2)	°C	-7	-7	-7	-7	-7	-7
SCOP	(1)(2)		3,67	3,71	3,78	3,67	3,80	3,73
Seasonal space heating energy efficiency	(1)(2)	%	144	145	148	144	149	146
Seasonal space heating energy efficiency class	(1)(2)		-	-	-	-	-	-

1 Seasonal space heating energy efficiency class LOW TEMPERATURE [REGULATION (EU) N. 813/2013]

2 Tipo di calcolo con portata variabile e temperatura variabile.

NX2-N-G06 / SL - LOW TEMPERATURE application			0546
Power supply		(V/ph/Hz)	400/3/50
WEATHER CONDITIONS - AVERAGE			
Rated heat output at Tdesignh	(1)(2)	kW	378
Bivalent temperature	(1)(2)	°C	-7
SCOP	(1)(2)		3,72
Seasonal space heating energy efficiency	(1)(2)	%	146
Seasonal space heating energy efficiency class	(1)(2)		-

1 Seasonal space heating energy efficiency class LOW TEMPERATURE [REGULATION (EU) N. 813/2013]

2 Tipo di calcolo con portata variabile e temperatura variabile.

TECHNICAL DATA SEASONAL EFFICIENCY IN HEATING (EN14825 VALUE)

Data Book
NX2-N-G06 0344 - 0808_202105_EN R454B

[SI System]

NX2-N-G06 / A - LOW TEMPERATURE application			0344	0364	0404	0446	0506	0526
Power supply		(V/ph/Hz)	400/3/50	400/3/50	400/3/50	400/3/50	400/3/50	400/3/50
WEATHER CONDITIONS - AVERAGE								
Rated heat output at Tdesignh	(1)(2)	kW	271	296	321	368	386	356
Bivalent temperature	(1)(2)	°C	-7	-7	-7	-7	-7	-10
SCOP	(1)(2)		3,76	3,83	3,79	3,90	3,81	3,80
Seasonal space heating energy efficiency	(1)(2)	%	147	150	149	153	149	149
Seasonal space heating energy efficiency class	(1)(2)		-	-	-	-	-	-

1 Seasonal space heating energy efficiency class LOW TEMPERATURE [REGULATION (EU) N. 813/2013]

2 Tipo di calcolo con portata variabile e temperatura variabile.

NX2-N-G06 / A - LOW TEMPERATURE application			0546
Power supply		(V/ph/Hz)	400/3/50
WEATHER CONDITIONS - AVERAGE			
Rated heat output at Tdesignh	(1)(2)	kW	371
Bivalent temperature	(1)(2)	°C	-10
SCOP	(1)(2)		3,83
Seasonal space heating energy efficiency	(1)(2)	%	150
Seasonal space heating energy efficiency class	(1)(2)		-

1 Seasonal space heating energy efficiency class LOW TEMPERATURE [REGULATION (EU) N. 813/2013]

2 Tipo di calcolo con portata variabile e temperatura variabile.

8 TECHNICAL DATA SEASONAL EFFICIENCY IN COOLING (EN14825 VALUE)

Data Book

NX2-N-G06 0344 - 0808_202105_EN R454B

[SI System]

ENERGY EFFICIENCY

SEASONAL EFFICIENCY IN COOLING (Reg. EU 2016/2281)

Ambient refrigeration

NX2-N-G06 / K			0344	0364	0404	0446	0506	0526	0546			
Prated,c	(1)	kW	334,3	354,7	382,0	430,2	475,1	515,9	533,1			
SEER	(1) (2)	-	3,93	4,04	4,07	4,01	3,93	4,07	4,10			
Performance η_s	(1) (3)	%	154,0	159,0	160,0	157,0	154,0	160,0	161,0			

NX2-N-G06 / SL			0344	0364	0404	0446	0506	0526	0546			
Prated,c	(1)	kW	316,0	336,4	370,2	409,0	443,6	486,1	505,7			
SEER	(1) (2)	-	4,10	4,13	4,23	4,14	4,10	4,19	4,19			
Performance η_s	(1) (3)	%	161,0	162,0	166,0	162,0	161,0	165,0	165,0			

NX2-N-G06 / A			0344	0364	0404	0446	0506	0526	0546	0606	0708	0738
Prated,c	(1)	kW	344,9	361,1	399,3	446,0	499,5	525,3	543,0	598,8	696,0	724,2
SEER	(1) (2)	-	4,28	4,39	4,44	4,36	4,28	4,37	4,37	4,56	4,56	4,56
Performance η_s	(1) (3)	%	168,0	172,0	175,0	171,0	168,0	172,0	172,0	180,0	179,0	180,0
NX2-N-G06 / A			0768	0808								
Prated,c	(1)	kW	761,4	798,6								
SEER	(1) (2)	-	4,58	4,56								
Performance η_s	(1) (3)	%	180,0	179,0								

Notes:

(1) Parameter calculated according to [REGULATION (EU) N. 2016/2281]

(2) Seasonal energy efficiency ratio

(3) Seasonal space cooling energy efficiency

The units highlighted in this publication contain R454B [GWP₁₀₀ 467] fluorinated greenhouse gases.

Data certified in EUROVENT

9 OPERATING LIMITS

9.1 Operating limits - Graphs

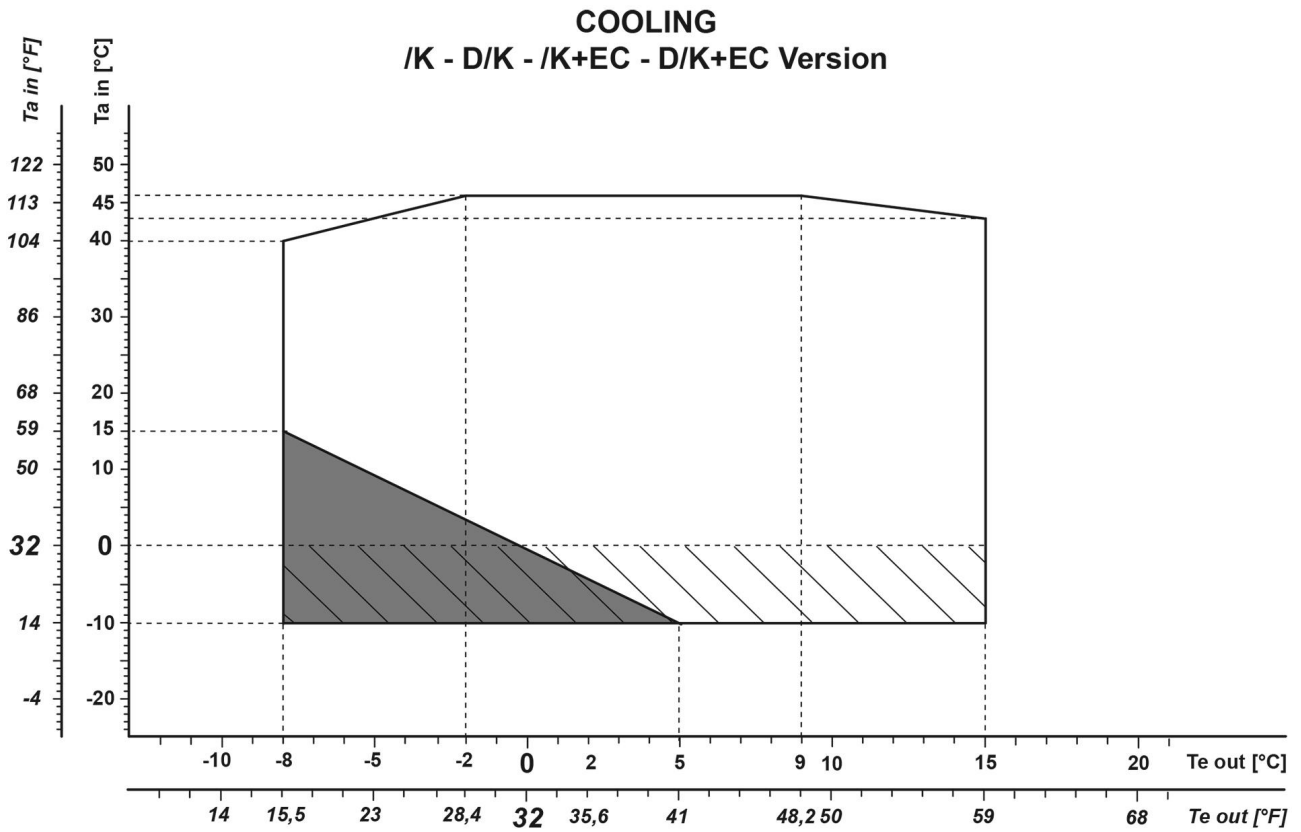

Ta in Outdoor air temperature [°C]
 Te out Evaporator outlet temperature [°C]

- Version STD
- EC fans option (code 808)
- Antifreeze heater on buffer tank (code 2421), if present

NOTE:
 For the temperature limits of each size please refer to the selection software ElcaWorld

OPERATING LIMITS

Data Book
 NX2-N-G06 0344 - 0808_202105_EN R454B

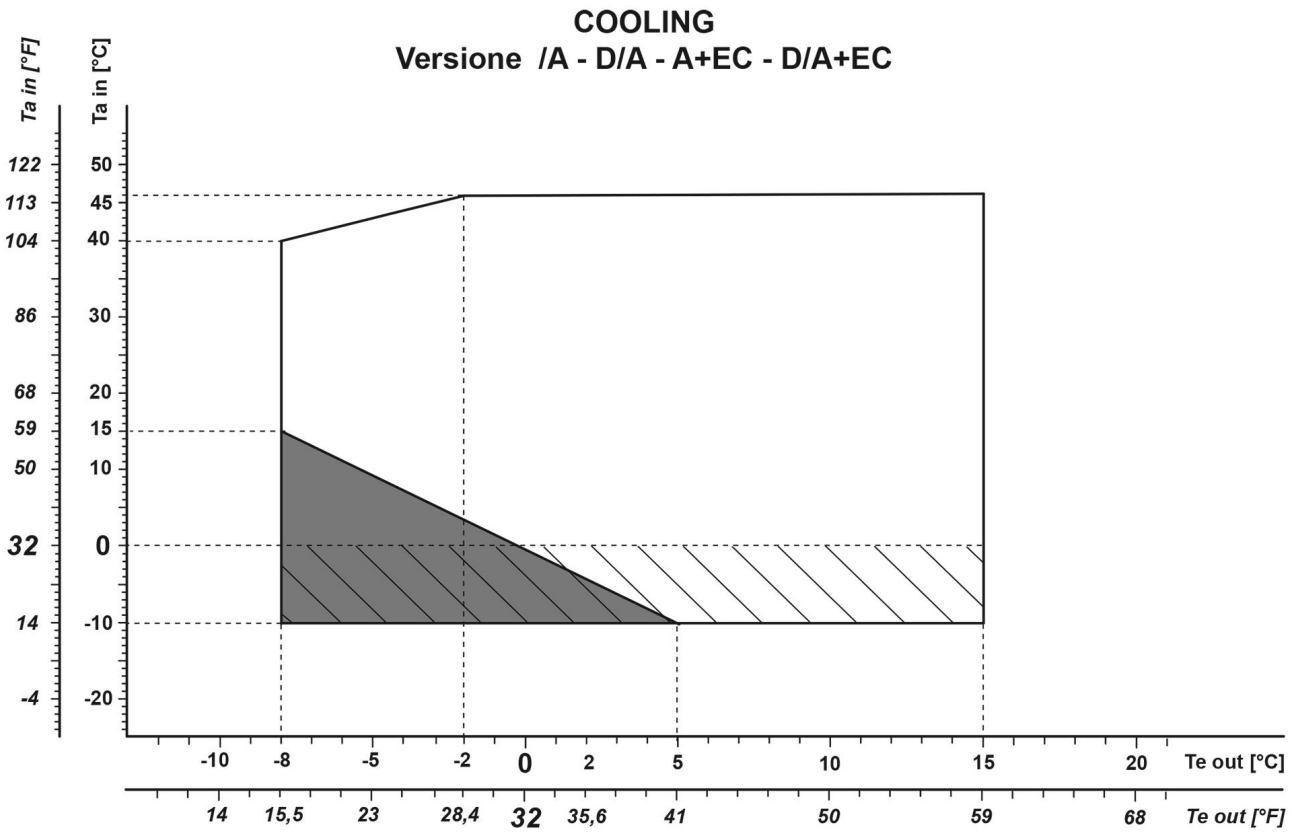

Ta in Outdoor air temperature [°C]
 Te out Evaporator outlet temperature [°C]

- Version STD
- EC fans: optional from size 0344 to size 0546; STD from size 0606 to size 0808
- Antifreeze heater on buffer tank (code 2421), if present



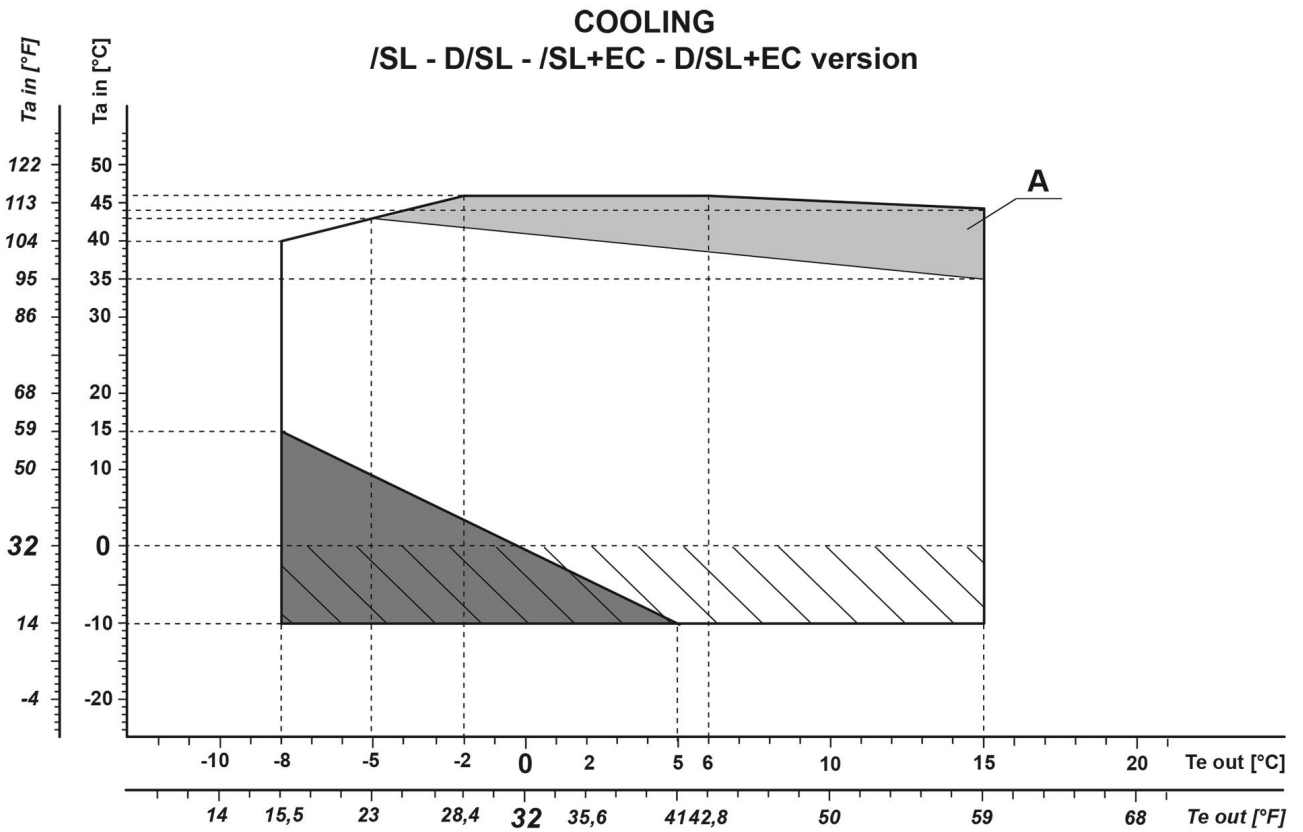

NOTE:
 For the temperature limits of each size please refer to the selection software ElcaWorld

OPERATING LIMITS

Data Book
 NX2-N-G06 0344 - 0808_202105_EN R454B



Ta in Outdoor air temperature [°C]
 Te out Evaporator outlet temperature [°C]

-  - Version STD
-  - EC fans option (code 808)
-  - Version SL: non-silent-mode operating area
-  - Antifreeze heater on buffer tank (code 2421), if present

NOTE:
 For the temperature limits of each size please refer to the selection software ElcaWorld

OPERATING LIMITS

Data Book
 NX2-N-G06 0344 - 0808_202105_EN R454B

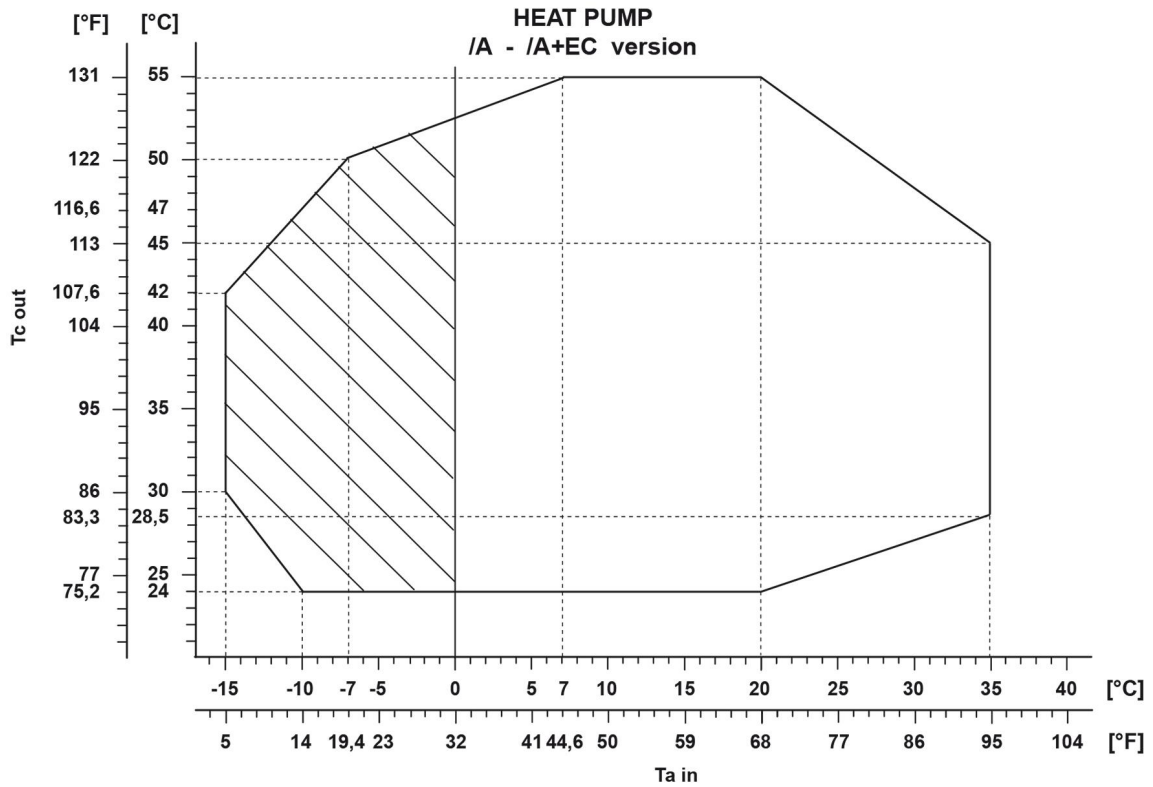
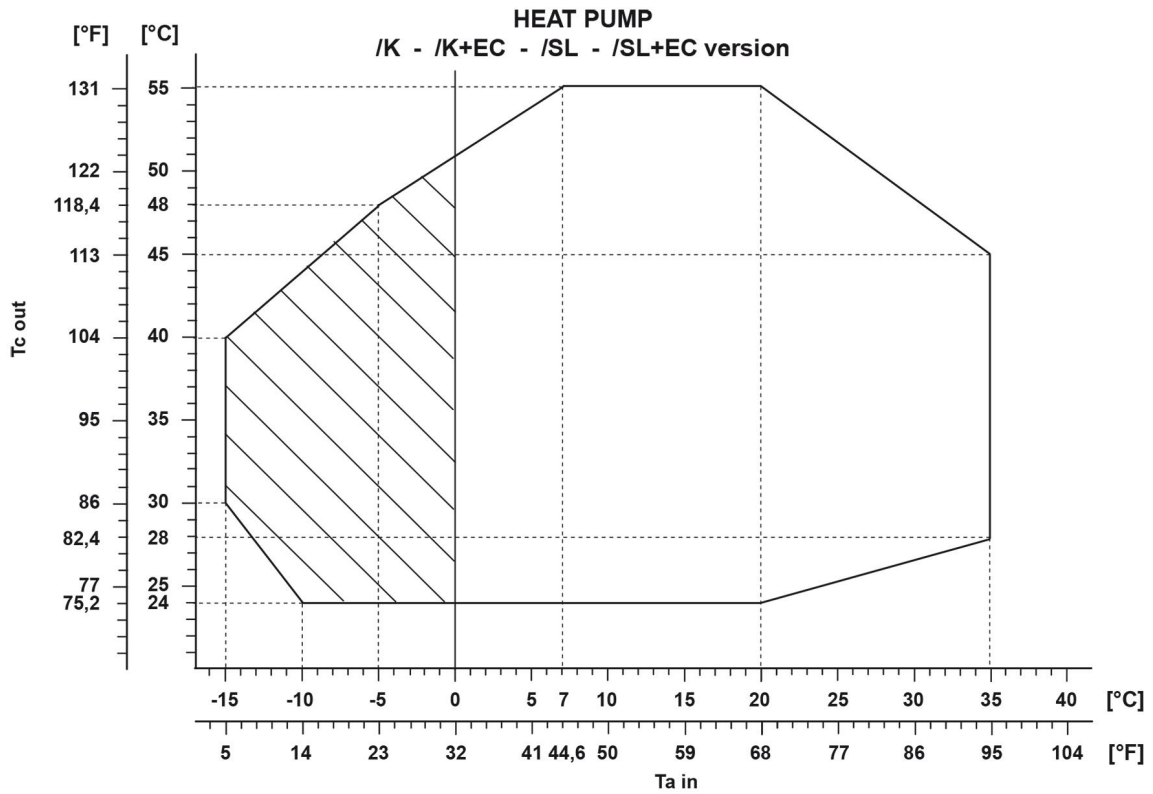

Ta in Outdoor air temperature
 Tc out Plant (side) heat exchanger water
 - Antifreeze heater on buffer tank (code 2421), if present

NOTE:
 For the temperature limits of each size please refer to the selection software ElcaWorld

9 OPERATING LIMITS

Data Book

NX2-N-G06 0344 - 0808_202105_EN R454B

SIZE
NX2-N-G06 /K /0344
NX2-N-G06 /K /0364
NX2-N-G06 /K /0404
NX2-N-G06 /K /0446
NX2-N-G06 /K /0506
NX2-N-G06 /K /0526
NX2-N-G06 /K /0546
NX2-N-G06 /D /K /0344
NX2-N-G06 /D /K /0364
NX2-N-G06 /D /K /0404
NX2-N-G06 /D /K /0446
NX2-N-G06 /D /K /0506
NX2-N-G06 /D /K /0526
NX2-N-G06 /D /K /0546
NX2-N-G06 /SL /0344
NX2-N-G06 /SL /0364
NX2-N-G06 /SL /0404
NX2-N-G06 /SL /0446
NX2-N-G06 /SL /0506
NX2-N-G06 /SL /0526
NX2-N-G06 /SL /0546
NX2-N-G06 /D /SL /0344
NX2-N-G06 /D /SL /0364
NX2-N-G06 /D /SL /0404
NX2-N-G06 /D /SL /0446
NX2-N-G06 /D /SL /0506
NX2-N-G06 /D /SL /0526
NX2-N-G06 /D /SL /0546
NX2-N-G06 /A /0344
NX2-N-G06 /A /0364
NX2-N-G06 /A /0404
NX2-N-G06 /A /0446
NX2-N-G06 /A /0506
NX2-N-G06 /A /0526
NX2-N-G06 /A /0546
NX2-N-G06 /A /0606
NX2-N-G06 /A /0708
NX2-N-G06 /A /0738
NX2-N-G06 /A /0768
NX2-N-G06 /A /0808
NX2-N-G06 /D /A /0344
NX2-N-G06 /D /A /0364
NX2-N-G06 /D /A /0404
NX2-N-G06 /D /A /0446
NX2-N-G06 /D /A /0506
NX2-N-G06 /D /A /0526
NX2-N-G06 /D /A /0546
NX2-N-G06 /D /A /0606
NX2-N-G06 /D /A /0708
NX2-N-G06 /D /A /0738
NX2-N-G06 /D /A /0768
NX2-N-G06 /D /A /0808

OPERATING LIMITS**Data Book****NX2-N-G06 0344 - 0808_202105_EN R454B****9.2 ETHYLENE GLYCOL MIXTURE**

Ethylene glycol and water mixture, used as a heat-conveying fluid, cause a variation in unit performance. For correct data, use the factors indicated in the following tabel.

	Freezing point (°C)							
	0	-5	-10	-15	-20	-25	-30	-35
	Ethylene glycol percentage by weight							
	0%	12%	20%	30%	35%	40%	45%	50%
cPf	1	0,985	0,98	0,974	0,97	0,965	0,964	0,96
cQ	1	1,02	1,04	1,075	1,11	1,14	1,17	1,2
cdp	1	1,07	1,11	1,18	1,22	1,24	1,27	1,3

cPf: cooling power correction factor

cQ: flow correction factor

cdp: pressure drop correction factor

For data concerning other kind of anti-freeze solutions (e.g, propylene glycol) please contact our Sale Department.

9.3 FOULING FACTORS

Performances are based on clean condition of tubes (fouling factor = 1). For different fouling values, performance should be adjusted using the correction factors shown in the following table.

SERIES	FOULING FACTORS	EVAPORATOR			CONDENSER/RECOVERY			DESUPERHEATER
	ff (m ² °CW)	F1	FK1	KE [°C]	F2	FK2	KC [°C]	R3
VARIOUS	0	1,000	1,000	0,0	1,000	1,000	0,0	1,000
VARIOUS	1,80 x 10 ⁻⁵	1,000	1,000	0,0	1,000	1,000	0,0	1,000
VARIOUS	4,40 x 10 ⁻⁵	1,000	1,000	0,0	0,990	1,030	1,0	0,990
VARIOUS	8,80 x 10 ⁻⁵	0,960	0,990	0,7	0,980	1,040	1,5	0,980
VARIOUS	13,20 x 10 ⁻⁵	0,944	0,985	1,0	0,964	1,050	2,3	0,964
VARIOUS	17,20 x 10 ⁻⁵	0,930	0,980	1,5	0,950	1,060	3,0	0,950

ff: fouling factors

F1 - F2: potential correction factors

FK1 - FK2: compressor power input correction factors

R3: capacity correction factors

KE: minimum evaporator outlet temperature increase

KC: maximum condenser outlet temperature decrease

10 HYDRAULIC DATA

Data Book

NX2-N-G06 0344 - 0808_202105_EN R454B

[SI System]

Water flow and pressure drop

Water flow in the plant (side) exchanger is given by:

$$Q = P / (4,186 \times \Delta t)$$

Q: water flow (l/s)

 Δt : difference between inlet and outlet water temp. (°C)

P: heat exchanger capacity (kW)

Pressure drop is given by:

$$\Delta p = K \times (3,6 \times Q)^2 / 1000$$

Q: water flow (l/s)

 Δp : pressure drop (kPa)

K: unit size ratio

SIZE	Power supply V/ph/Hz	HEAT EXCHANGER USER SIDE					HEAT RECOVERY EX. USER SIDE			
		K	Q min l/s	Q max l/s	C.A.S. l	C.a. min l	K	Q min l/s	Q max l/s	C.A.S. l
NX2-N-G06 /K /0344	400/3/50	14,5	10,58	27,58	79,0	890	-	-	-	-
NX2-N-G06 /K /0364	400/3/50	10,3	11,31	26,72	67,0	930	-	-	-	-
NX2-N-G06 /K /0404	400/3/50	10,3	12,33	29,92	67,0	1030	-	-	-	-
NX2-N-G06 /K /0446	400/3/50	7,90	13,89	36,11	140	1150	-	-	-	-
NX2-N-G06 /K /0506	400/3/50	7,90	13,89	36,11	140	1290	-	-	-	-
NX2-N-G06 /K /0526	400/3/50	5,50	17,50	38,89	128	1360	-	-	-	-
NX2-N-G06 /K /0546	400/3/50	5,50	17,50	38,89	128	1400	-	-	-	-
NX2-N-G06 /D /K /0344	400/3/50	14,5	10,58	27,58	79,0	890	117	-	6,083	2,21
NX2-N-G06 /D /K /0364	400/3/50	10,3	11,31	26,72	67,0	930	101	-	6,389	2,52
NX2-N-G06 /D /K /0404	400/3/50	10,3	12,33	29,92	67,0	1030	101	-	7,417	2,52
NX2-N-G06 /D /K /0446	400/3/50	7,90	13,89	36,11	140	1150	67,0	-	8,000	2,84
NX2-N-G06 /D /K /0506	400/3/50	7,90	13,89	36,11	140	1290	67,0	-	8,528	2,84
NX2-N-G06 /D /K /0526	400/3/50	5,50	17,50	38,89	128	1360	49,0	-	9,222	3,47
NX2-N-G06 /D /K /0546	400/3/50	5,50	17,50	38,89	128	1400	45,0	-	9,611	3,78
NX2-N-G06 /SL /0344	400/3/50	14,5	10,58	27,58	79,0	890	-	-	-	-
NX2-N-G06 /SL /0364	400/3/50	10,3	11,31	26,72	67,0	930	-	-	-	-
NX2-N-G06 /SL /0404	400/3/50	10,3	12,33	29,92	67,0	1030	-	-	-	-
NX2-N-G06 /SL /0446	400/3/50	7,90	13,89	36,11	140	1150	-	-	-	-
NX2-N-G06 /SL /0506	400/3/50	7,90	13,89	36,11	140	1290	-	-	-	-
NX2-N-G06 /SL /0526	400/3/50	5,50	17,50	38,89	128	1360	-	-	-	-
NX2-N-G06 /SL /0546	400/3/50	5,50	17,50	38,89	128	1400	-	-	-	-
NX2-N-G06 /D /SL /0344	400/3/50	14,5	10,58	27,58	79,0	890	117	-	6,083	2,21
NX2-N-G06 /D /SL /0364	400/3/50	10,3	11,31	26,72	67,0	930	101	-	6,389	2,52
NX2-N-G06 /D /SL /0404	400/3/50	10,3	12,33	29,92	67,0	1030	101	-	7,417	2,52
NX2-N-G06 /D /SL /0446	400/3/50	7,90	13,89	36,11	140	1150	67,0	-	8,000	2,84
NX2-N-G06 /D /SL /0506	400/3/50	7,90	13,89	36,11	140	1290	67,0	-	8,528	2,84
NX2-N-G06 /D /SL /0526	400/3/50	5,50	17,50	38,89	128	1360	49,0	-	9,222	3,47
NX2-N-G06 /D /SL /0546	400/3/50	5,50	17,50	38,89	128	1400	45,0	-	9,611	3,78
NX2-N-G06 /A /0344	400/3/50	14,5	10,58	27,58	79,0	890	-	-	-	-
NX2-N-G06 /A /0364	400/3/50	10,3	11,31	26,72	67,0	930	-	-	-	-
NX2-N-G06 /A /0404	400/3/50	10,3	12,33	29,92	67,0	1030	-	-	-	-
NX2-N-G06 /A /0446	400/3/50	7,90	13,89	36,11	140	1150	-	-	-	-
NX2-N-G06 /A /0506	400/3/50	7,90	13,89	36,11	140	1290	-	-	-	-
NX2-N-G06 /A /0526	400/3/50	5,50	17,50	38,89	128	1360	-	-	-	-
NX2-N-G06 /A /0546	400/3/50	5,50	17,50	38,89	128	1400	-	-	-	-
NX2-N-G06 /A /0606	400/3/50	4,80	17,50	41,67	116	1500	-	-	-	-
NX2-N-G06 /A /0708	400/3/50	3,50	21,14	51,72	169	1740	-	-	-	-

Q min: minimum water flow admitted to the heat exchanger
 Q max: maximum water flow admitted to the heat exchanger
 C.a. min: minimum water content admitted in the plant
 C.A.S.: Exchanger water content

HYDRAULIC DATA**Data Book****NX2-N-G06 0344 - 0808_202105_EN R454B**

[SI System]

SIZE	Power supply V/ph/Hz	HEAT EXCHANGER USER SIDE					HEAT RECOVERY EX. USER SIDE			
		K	Q min l/s	Q max l/s	C.A.S. l	C.a. min l	K	Q min l/s	Q max l/s	C.A.S. l
NX2-N-G06 /A /0738	400/3/50	2,60	22,67	56,67	157	1810	-	-	-	-
NX2-N-G06 /A /0768	400/3/50	2,60	23,72	56,67	157	1900	-	-	-	-
NX2-N-G06 /A /0808	400/3/50	2,60	24,69	60,36	157	2000	-	-	-	-
NX2-N-G06 /D /A /0344	400/3/50	14,5	10,58	27,58	79,0	890	117	-	6,083	2,21
NX2-N-G06 /D /A /0364	400/3/50	10,3	11,31	26,72	67,0	930	101	-	6,389	2,52
NX2-N-G06 /D /A /0404	400/3/50	10,3	12,33	29,92	67,0	1030	101	-	7,417	2,52
NX2-N-G06 /D /A /0446	400/3/50	7,90	13,89	36,11	140	1150	67,0	-	8,000	2,84
NX2-N-G06 /D /A /0506	400/3/50	7,90	13,89	36,11	140	1290	67,0	-	8,528	2,84
NX2-N-G06 /D /A /0526	400/3/50	5,50	17,50	38,89	128	1360	49,0	-	9,222	3,47
NX2-N-G06 /D /A /0546	400/3/50	5,50	17,50	38,89	128	1400	45,0	-	9,611	3,78
NX2-N-G06 /D /A /0606	400/3/50	4,80	17,50	41,67	116	1500	45,0	-	11,14	3,78
NX2-N-G06 /D /A /0708	400/3/50	3,50	21,14	51,72	169	1740	33,0	-	12,22	3,78
NX2-N-G06 /D /A /0738	400/3/50	2,60	22,67	56,67	157	1810	29,0	-	12,81	5,04
NX2-N-G06 /D /A /0768	400/3/50	2,60	23,72	56,67	157	1900	29,0	-	13,81	5,04
NX2-N-G06 /D /A /0808	400/3/50	2,60	24,69	60,36	157	2000	29,0	-	14,89	5,04

Q min: minimum water flow admitted to the heat exchanger
Q max: maximum water flow admitted to the heat exchanger
C.a. min: minimum water content admitted in the plant
C.A.S.: Exchanger water content

11 ELECTRICAL DATA

Data Book

NX2-N-G06 0344 - 0808_202105_EN R454B

11.1 ELECTRIC DATA

[SI System]

NX2-N-G06 / K

SIZE	Power supply V/ph/Hz	Maximum values								
		n	Compressor			Fans (1)		Total (1)(2)		
			F.L.I. [kW]	F.L.A. [A]	L.R.A. [A]	F.L.I. [kW]	F.L.A. [A]	F.L.I. [kW]	F.L.A. [A]	S.A. [A]
0344	400/3/50	4	3x34,5+1x42	3x55,1+1x68,4	3x326+1x298	1,900	4	156,8	257	515
0364	400/3/50	4	2x34,5+2x42	2x55,1+2x68,4	2x326+2x298	1,900	4	164,3	270	528
0404	400/3/50	4	4x42	4x68,4	4x298	1,900	4	179,3	297	526
0446	400/3/50	6	2x27+4x34,5	2x42,5+4x55,1	2x210+4x326	1,900	4	205,2	333	604
0506	400/3/50	6	6x34,5	6x55,1	6x326	1,900	4	223,9	365	636
0526	400/3/50	6	6x34,5	6x55,1	6x326	1,900	4	238,9	392	650
0546	400/3/50	6	3x34,5+3x42	3x55,1+3x68,4	3x326+3x298	1,900	4	246,4	405	663

F.L.I.: Full load power

F.L.A.: Full load current

L.R.A.: Locked rotor amperes for single compressor

S.A.: Inrush current

(1) Values calculated referring to the version with the maximum number of fans working at the max absorbed current

(1)(2) Safety values to be considered when cabling the unit for power supply and line-protections

Data valid for standard units without any additional option.

Plant (side) cooling exchanger water (in/out) 12,00°C/7,00°C; Source (side) heat exchanger air (in) 35,0°C.

Voltage tolerance: 10%

Maximum voltage unbalance: 2%

Give the typical operating conditions of units designed for outdoor installation, which can be associated (according to reference document IEC 60721) to the following classes:

- climatic conditions class 4K4H: air temperature range from -20 up to 55°C (*), relative humidity range from 4 up to 100%, with possible precipitations, at air pressure from 70 and 106 kPa and a maximum solar radiation of 1120 W/m²

- special climatic conditions negligible

- biological conditions class 4B1 and 4C2: locations in a generic urban area

- mechanically active substances class 4S2: locations in areas with sand or dust representative of urban areas

- mechanical conditions class 4M1: locations protected from significant vibrations or shocks

The required protection level for safe operation, according to reference document IEC 60529, is IP43XW (protection against access, to the most critical unit's parts, of external devices with diameter larger than 1 mm and rain).

The unit can be considered IP44XW protected, i.e. protected against access of external devices (with diameter larger than 1 mm) and water in general.

(*) for the unit's operating limits, see "selection limits" section

ELECTRICAL DATA**Data Book****NX2-N-G06 0344 - 0808_202105_EN R454B**

[SI System]

NX2-N-G06 / SL

SIZE	Power supply V/ph/Hz	Maximum values								
		n	Compressor			Fans (1)		Total (1)(2)		
			F.L.I. [kW]	F.L.A. [A]	L.R.A. [A]	F.L.I. [kW]	F.L.A. [A]	F.L.I. [kW]	F.L.A. [A]	S.A. [A]
0344	400/3/50	4	3x34,5+1x42	3x55,1+1x68,4	3x326+1x298	1,200	2	156,8	257	515
0364	400/3/50	4	2x34,5+2x42	2x55,1+2x68,4	2x326+2x298	1,200	2	164,3	270	528
0404	400/3/50	4	4x42	4x68,4	4x298	1,200	2	179,3	297	526
0446	400/3/50	6	2x27+4x34,5	2x42,5+4x55,1	2x210+4x326	1,200	2	205,2	333	604
0506	400/3/50	6	6x34,5	6x55,1	6x326	1,200	2	223,9	365	636
0526	400/3/50	6	6x34,5	6x55,1	6x326	1,200	2	238,9	392	650
0546	400/3/50	6	3x34,5+3x42	3x55,1+3x68,4	3x326+3x298	1,200	2	246,4	405	663

F.L.I.: Full load power

F.L.A.: Full load current

L.R.A.: Locked rotor amperes for single compressor

S.A.: Inrush current

(1) Values calculated referring to the version with the maximum number of fans working at the max absorbed current

(1)(2) Safety values to be considered when cabling the unit for power supply and line-protections

Data valid for standard units without any additional option.

Plant (side) cooling exchanger water (in/out) 12,00°C/7,00°C; Source (side) heat exchanger air (in) 35,0°C.

Voltage tolerance: 10%

Maximum voltage unbalance: 2%

Give the typical operating conditions of units designed for outdoor installation, which can be associated (according to reference document IEC 60721) to the following classes:

- climatic conditions class 4K4H: air temperature range from -20 up to 55°C (*), relative humidity range from 4 up to 100%, with possible precipitations, at air pressure from 70 and 106 kPa and a maximum solar radiation of 1120 W/m²

- special climatic conditions negligible

- biological conditions class 4B1 and 4C2: locations in a generic urban area

- mechanically active substances class 4S2: locations in areas with sand or dust representative of urban areas

- mechanical conditions class 4M1: locations protected from significant vibrations or shocks

The required protection level for safe operation, according to reference document IEC 60529, is IP43XW (protection against access, to the most critical unit's parts, of external devices with diameter larger than 1 mm and rain).

The unit can be considered IP44XW protected, i.e. protected against access of external devices (with diameter larger than 1 mm) and water in general.

(*) for the unit's operating limits, see "selection limits" section

ELECTRICAL DATA

Data Book
NX2-N-G06 0344 - 0808_202105_EN R454B

[SI System]

NX2-N-G06 / A

SIZE	Power supply V/ph/Hz	Maximum values								
		n	Compressor			Fans (1)		Total (1)(2)		
			F.L.I. [kW]	F.L.A. [A]	L.R.A. [A]	F.L.I. [kW]	F.L.A. [A]	F.L.I. [kW]	F.L.A. [A]	S.A. [A]
0344	400/3/50	4	3x34,5+1x42	3x55,1+1x68,4	3x326+1x298	1,900	4	160,7	265	523
0364	400/3/50	4	2x34,5+2x42	2x55,1+2x68,4	2x326+2x298	1,900	4	168,2	278	536
0404	400/3/50	4	4x42	4x68,4	4x298	1,900	4	183,2	305	534
0446	400/3/50	6	2x27+4x34,5	2x42,5+4x55,1	2x210+4x326	1,900	4	210,9	344	615
0506	400/3/50	6	6x34,5	6x55,1	6x326	1,900	4	229,8	377	648
0526	400/3/50	6	6x34,5	6x55,1	6x326	1,900	4	244,8	404	662
0546	400/3/50	6	3x34,5+3x42	3x55,1+3x68,4	3x326+3x298	1,900	4	252,3	417	675
0606	400/3/50	6	6x42	6x68,4	6x298	1,700	3	272,4	443	672
0708	400/3/50	8	6x34,5+2x42	6x55,1+2x68,4	6x326+2x298	1,700	3	318,2	511	768
0738	400/3/50	8	4x34,5+4x42	4x55,1+4x68,4	4x326+4x298	1,700	3	333,2	537	795
0768	400/3/50	8	2x34,5+6x42	2x55,1+6x68,4	2x326+6x298	1,700	3	348,2	564	821
0808	400/3/50	8	8x42	8x68,4	8x298	1,700	3	363,2	590	820

F.L.I.: Full load power

F.L.A.: Full load current

L.R.A.: Locked rotor amperes for single compressor

S.A.: Inrush current

(1) Values calculated referring to the version with the maximum number of fans working at the max absorbed current

(1)(2) Safety values to be considered when cabling the unit for power supply and line-protections

Data valid for standard units without any additional option.

Plant (side) cooling exchanger water (in/out) 12,00°C/7,00°C; Source (side) heat exchanger air (in) 35,0°C.

Voltage tolerance: 10%

Maximum voltage unbalance: 2%

Give the typical operating conditions of units designed for outdoor installation, which can be associated (according to reference document IEC 60721) to the following classes:

- climatic conditions class 4K4H: air temperature range from -20 up to 55°C (*), relative humidity range from 4 up to 100%, with possible precipitations, at air pressure from 70 and 106 kPa and a maximum solar radiation of 1120 W/m²
- special climatic conditions negligible

- biological conditions class 4B1 and 4C2: locations in a generic urban area

- mechanically active substances class 4S2: locations in areas with sand or dust representative of urban areas

- mechanical conditions class 4M1: locations protected from significant vibrations or shocks

The required protection level for safe operation, according to reference document IEC 60529, is IP43XW (protection against access, to the most critical unit's parts, of external devices with diameter larger than 1 mm and rain).

The unit can be considered IP44XW protected, i.e. protected against access of external devices (with diameter larger than 1 mm) and water in general.

(*) for the unit's operating limits, see "selection limits" section

11 ELECTRIC DATA

Data Book

NX2-N-G06 0344 - 0808_202105_EN R454B

11.2 Dimensions of the electrical connections to the main switch**Maximum cables/bars section connected to main switch and short time current**

SIZE	TYPE	MAXIMUM CABLE SECTION CONNECTED TO MAIN SWITCH ∅ [mm ²]	MAXIMUM BAR SECTION CONNECTED TO MAIN SWITCH □ [mm]	Maximum back-up fuse rating [A]	ICW (0,3 s) short time current rms [kA]	Further technical data
0344	SIRCO 400A	min 185 max 240	max 2x40x5	400	25	https://www.socomec.com/files/live/sites/systemsite/files/SCP/pdf_catalogue/GB/cat_sircosircoac_en.pdf
0364						
0404						
0446	SIRCO 500A	min 240 max 240	max 2x40x5	500		
0506						
0526	SIRCO 630A	min 2 x 150 max 2 x 300	min 2x30x5 max 2x50x5	630		
0546						
0606						
0708	SIRCO 800A	min 2 x 185 max 2 x 300	min 2x40x5 max 2x63x5	800	27	
0738						
0768						
0808						

12 FULL LOAD SOUND LEVEL**Data Book****NX2-N-G06 0344 - 0808_202105_EN R454B**

NX2-N-G06 / K

SOUND POWER LEVEL IN COOLING									
SIZE	Octave band [Hz]								Total sound level dB(A)
	63	125	250	500	1000	2000	4000	8000	
	Sound power level dB								
0344	99	98	95	93	92	87	81	76	96
0364	99	98	95	93	92	87	81	76	96
0404	99	98	95	93	92	87	81	76	96
0446	99	98	95	93	92	87	81	76	96
0506	100	99	96	94	93	88	82	76	97
0526	100	99	96	94	93	88	82	76	97
0546	100	99	96	94	93	88	82	76	97

Working conditions

Plant (side) cooling exchanger water (in/out) 12,00°C/7,00°C; Source (side) heat exchanger air (in) 35,0°C.

Sound power on the basis of measurements taken in compliance with ISO 9614.

Such certification refers specifically to the sound Power Level in dB(A). This is therefore the only acoustic data to be considered as binding.

Sound power level in cooling, outdoors.

NX2-N-G06 / K

SOUND PRESSURE LEVEL									
SIZE	Octave band [Hz]								Total sound level dB(A)
	63	125	250	500	1000	2000	4000	8000	
	Sound pressure level dB								
0344	79	78	75	73	72	67	61	56	76
0364	79	78	75	73	72	67	61	56	76
0404	79	78	75	73	72	67	61	56	76
0446	79	78	75	73	72	67	61	56	76
0506	79	78	75	73	72	67	61	55	76
0526	79	78	75	73	72	67	61	55	76
0546	79	78	75	73	72	67	61	55	76

Working conditions

Plant (side) cooling exchanger water (in/out) 12,00°C/7,00°C; Source (side) heat exchanger air (in) 35,0°C.

Average sound pressure level at 1m distance, unit in a free field on a reflective surface; non-binding value calculated from the sound power level.

FULL LOAD SOUND LEVEL**Data Book****NX2-N-G06 0344 - 0808_202105_EN R454B**

NX2-N-G06 / K

SOUND POWER LEVEL IN HEATING									
SIZE	Octave band [Hz]								Total sound level dB(A)
	63	125	250	500	1000	2000	4000	8000	
	Sound power level dB								
0344	N.A.	N.A.	N.A.	N.A.	N.A.	N.A.	N.A.	N.A.	96
0364	N.A.	N.A.	N.A.	N.A.	N.A.	N.A.	N.A.	N.A.	96
0404	N.A.	N.A.	N.A.	N.A.	N.A.	N.A.	N.A.	N.A.	96
0446	N.A.	N.A.	N.A.	N.A.	N.A.	N.A.	N.A.	N.A.	96
0506	N.A.	N.A.	N.A.	N.A.	N.A.	N.A.	N.A.	N.A.	97
0526	N.A.	N.A.	N.A.	N.A.	N.A.	N.A.	N.A.	N.A.	97
0546	N.A.	N.A.	N.A.	N.A.	N.A.	N.A.	N.A.	N.A.	97

Working conditions

Sound power on the basis of measurements taken in compliance with ISO 9614.

Such certification refers specifically to the sound Power Level in dB(A). This is therefore the only acoustic data to be considered as binding.

Sound power level in heating, outdoors.

N.A.: Not available

NX2-N-G06 / K

SOUND PRESSURE LEVEL									
SIZE	Octave band [Hz]								Total sound level dB(A)
	63	125	250	500	1000	2000	4000	8000	
	Sound pressure level dB								
0344	N.A.	N.A.	N.A.	N.A.	N.A.	N.A.	N.A.	N.A.	76
0364	N.A.	N.A.	N.A.	N.A.	N.A.	N.A.	N.A.	N.A.	76
0404	N.A.	N.A.	N.A.	N.A.	N.A.	N.A.	N.A.	N.A.	76
0446	N.A.	N.A.	N.A.	N.A.	N.A.	N.A.	N.A.	N.A.	76
0506	N.A.	N.A.	N.A.	N.A.	N.A.	N.A.	N.A.	N.A.	76
0526	N.A.	N.A.	N.A.	N.A.	N.A.	N.A.	N.A.	N.A.	76
0546	N.A.	N.A.	N.A.	N.A.	N.A.	N.A.	N.A.	N.A.	76

Working conditions

Average sound pressure level at 1m distance, unit in a free field on a reflective surface; non-binding value calculated from the sound power level.

N.A.: Not available

FULL LOAD SOUND LEVEL**Data Book****NX2-N-G06 0344 - 0808_202105_EN R454B**

NX2-N-G06 / SL

SOUND POWER LEVEL IN COOLING									
SIZE	Octave band [Hz]								Total sound level dB(A)
	63	125	250	500	1000	2000	4000	8000	
	Sound power level dB								
0344	90	89	88	86	83	78	71	65	88
0364	90	89	88	86	83	78	71	65	88
0404	90	89	88	86	83	78	71	65	88
0446	91	90	89	87	84	79	72	66	89
0506	91	90	89	87	84	79	72	66	89
0526	92	91	90	88	85	80	73	67	90
0546	92	91	90	88	85	80	73	67	90

Working conditions

Plant (side) cooling exchanger water (in/out) 12,00°C/7,00°C; Source (side) heat exchanger air (in) 35,0°C.

Sound power on the basis of measurements taken in compliance with ISO 9614.

Such certification refers specifically to the sound Power Level in dB(A). This is therefore the only acoustic data to be considered as binding.

Sound power level in cooling, outdoors.

NX2-N-G06 / SL

SOUND PRESSURE LEVEL									
SIZE	Octave band [Hz]								Total sound level dB(A)
	63	125	250	500	1000	2000	4000	8000	
	Sound pressure level dB								
0344	70	69	68	66	63	58	51	45	68
0364	70	69	68	66	63	58	51	45	68
0404	70	69	68	66	63	58	51	45	68
0446	70	69	68	66	63	58	51	45	68
0506	70	69	68	66	63	58	51	45	68
0526	71	70	69	67	64	59	52	46	69
0546	71	70	69	67	64	59	52	46	69

Working conditions

Plant (side) cooling exchanger water (in/out) 12,00°C/7,00°C; Source (side) heat exchanger air (in) 35,0°C.

Average sound pressure level at 1m distance, unit in a free field on a reflective surface; non-binding value calculated from the sound power level.

FULL LOAD SOUND LEVEL**Data Book****NX2-N-G06 0344 - 0808_202105_EN R454B**

NX2-N-G06 / SL

SOUND POWER LEVEL IN HEATING									
SIZE	Octave band [Hz]								Total sound level dB(A)
	63	125	250	500	1000	2000	4000	8000	
	Sound power level dB								
0344	N.A.	N.A.	N.A.	N.A.	N.A.	N.A.	N.A.	N.A.	89
0364	N.A.	N.A.	N.A.	N.A.	N.A.	N.A.	N.A.	N.A.	89
0404	N.A.	N.A.	N.A.	N.A.	N.A.	N.A.	N.A.	N.A.	89
0446	N.A.	N.A.	N.A.	N.A.	N.A.	N.A.	N.A.	N.A.	90
0506	N.A.	N.A.	N.A.	N.A.	N.A.	N.A.	N.A.	N.A.	90
0526	N.A.	N.A.	N.A.	N.A.	N.A.	N.A.	N.A.	N.A.	91
0546	N.A.	N.A.	N.A.	N.A.	N.A.	N.A.	N.A.	N.A.	91

Working conditions

Sound power on the basis of measurements taken in compliance with ISO 9614.

Such certification refers specifically to the sound Power Level in dB(A). This is therefore the only acoustic data to be considered as binding.

Sound power level in heating, outdoors.

N.A.: Not available

NX2-N-G06 / SL

SOUND PRESSURE LEVEL									
SIZE	Octave band [Hz]								Total sound level dB(A)
	63	125	250	500	1000	2000	4000	8000	
	Sound pressure level dB								
0344	N.A.	N.A.	N.A.	N.A.	N.A.	N.A.	N.A.	N.A.	69
0364	N.A.	N.A.	N.A.	N.A.	N.A.	N.A.	N.A.	N.A.	69
0404	N.A.	N.A.	N.A.	N.A.	N.A.	N.A.	N.A.	N.A.	69
0446	N.A.	N.A.	N.A.	N.A.	N.A.	N.A.	N.A.	N.A.	69
0506	N.A.	N.A.	N.A.	N.A.	N.A.	N.A.	N.A.	N.A.	69
0526	N.A.	N.A.	N.A.	N.A.	N.A.	N.A.	N.A.	N.A.	70
0546	N.A.	N.A.	N.A.	N.A.	N.A.	N.A.	N.A.	N.A.	70

Working conditions

Average sound pressure level at 1m distance, unit in a free field on a reflective surface; non-binding value calculated from the sound power level.

N.A.: Not available

FULL LOAD SOUND LEVEL

Data Book
NX2-N-G06 0344 - 0808_202105_EN R454B

NX2-N-G06 / A

SOUND POWER LEVEL IN COOLING									
SIZE	Octave band [Hz]								Total sound level dB(A)
	63	125	250	500	1000	2000	4000	8000	
	Sound power level dB								
0344	100	99	96	94	93	88	82	76	97
0364	100	99	96	94	93	88	82	76	97
0404	100	99	96	94	93	88	82	76	97
0446	100	99	96	94	93	88	82	76	97
0506	100	99	97	95	94	89	83	77	98
0526	100	99	97	95	94	89	83	77	98
0546	100	99	97	95	94	89	83	77	98
0606	101	100	98	96	95	90	84	78	99
0708	101	100	98	96	95	90	84	78	99
0738	101	101	99	97	96	91	85	78	100
0768	101	101	99	97	96	91	85	78	100
0808	101	101	99	97	96	91	85	78	100

Working conditions

Plant (side) cooling exchanger water (in/out) 12,00°C/7,00°C; Source (side) heat exchanger air (in) 35,0°C.

Sound power on the basis of measurements taken in compliance with ISO 9614.

Such certification refers specifically to the sound Power Level in dB(A). This is therefore the only acoustic data to be considered as binding.

Sound power level in cooling, outdoors.

NX2-N-G06 / A

SOUND PRESSURE LEVEL									
SIZE	Octave band [Hz]								Total sound level dB(A)
	63	125	250	500	1000	2000	4000	8000	
	Sound pressure level dB								
0344	80	79	76	74	73	68	62	56	77
0364	80	79	76	74	73	68	62	56	77
0404	80	79	76	74	73	68	62	56	77
0446	79	78	75	73	72	67	61	55	76
0506	79	78	76	74	73	68	62	56	77
0526	79	78	76	74	73	68	62	56	77
0546	79	78	76	74	73	68	62	56	77
0606	80	79	77	75	74	69	63	57	78
0708	79	78	76	74	73	68	62	56	77
0738	79	79	77	75	74	69	63	56	78
0768	79	79	77	75	74	69	63	56	78
0808	79	79	77	75	74	69	63	56	78

Working conditions

Plant (side) cooling exchanger water (in/out) 12,00°C/7,00°C; Source (side) heat exchanger air (in) 35,0°C.

Average sound pressure level at 1m distance, unit in a free field on a reflective surface; non-binding value calculated from the sound power level.

FULL LOAD SOUND LEVEL

Data Book
NX2-N-G06 0344 - 0808_202105_EN R454B

NX2-N-G06 / A

SOUND POWER LEVEL IN HEATING									
SIZE	Octave band [Hz]								Total sound level dB(A)
	63	125	250	500	1000	2000	4000	8000	
	Sound power level dB								
0344	N.A.	N.A.	N.A.	N.A.	N.A.	N.A.	N.A.	N.A.	97
0364	N.A.	N.A.	N.A.	N.A.	N.A.	N.A.	N.A.	N.A.	97
0404	N.A.	N.A.	N.A.	N.A.	N.A.	N.A.	N.A.	N.A.	97
0446	N.A.	N.A.	N.A.	N.A.	N.A.	N.A.	N.A.	N.A.	97
0506	N.A.	N.A.	N.A.	N.A.	N.A.	N.A.	N.A.	N.A.	98
0526	N.A.	N.A.	N.A.	N.A.	N.A.	N.A.	N.A.	N.A.	98
0546	N.A.	N.A.	N.A.	N.A.	N.A.	N.A.	N.A.	N.A.	98
0606	N.A.	N.A.	N.A.	N.A.	N.A.	N.A.	N.A.	N.A.	0
0708	N.A.	N.A.	N.A.	N.A.	N.A.	N.A.	N.A.	N.A.	0
0738	N.A.	N.A.	N.A.	N.A.	N.A.	N.A.	N.A.	N.A.	0
0768	N.A.	N.A.	N.A.	N.A.	N.A.	N.A.	N.A.	N.A.	0
0808	N.A.	N.A.	N.A.	N.A.	N.A.	N.A.	N.A.	N.A.	0

Working conditions

Sound power on the basis of measurements taken in compliance with ISO 9614.

Such certification refers specifically to the sound Power Level in dB(A). This is therefore the only acoustic data to be considered as binding.

Sound power level in heating, outdoors.

N.A.: Not available

NX2-N-G06 / A

SOUND PRESSURE LEVEL									
SIZE	Octave band [Hz]								Total sound level dB(A)
	63	125	250	500	1000	2000	4000	8000	
	Sound pressure level dB								
0344	N.A.	N.A.	N.A.	N.A.	N.A.	N.A.	N.A.	N.A.	77
0364	N.A.	N.A.	N.A.	N.A.	N.A.	N.A.	N.A.	N.A.	77
0404	N.A.	N.A.	N.A.	N.A.	N.A.	N.A.	N.A.	N.A.	77
0446	N.A.	N.A.	N.A.	N.A.	N.A.	N.A.	N.A.	N.A.	76
0506	N.A.	N.A.	N.A.	N.A.	N.A.	N.A.	N.A.	N.A.	77
0526	N.A.	N.A.	N.A.	N.A.	N.A.	N.A.	N.A.	N.A.	77
0546	N.A.	N.A.	N.A.	N.A.	N.A.	N.A.	N.A.	N.A.	77
0606	N.A.	N.A.	N.A.	N.A.	N.A.	N.A.	N.A.	N.A.	0
0708	N.A.	N.A.	N.A.	N.A.	N.A.	N.A.	N.A.	N.A.	0
0738	N.A.	N.A.	N.A.	N.A.	N.A.	N.A.	N.A.	N.A.	0
0768	N.A.	N.A.	N.A.	N.A.	N.A.	N.A.	N.A.	N.A.	0
0808	N.A.	N.A.	N.A.	N.A.	N.A.	N.A.	N.A.	N.A.	0

Working conditions

Average sound pressure level at 1m distance, unit in a free field on a reflective surface; non-binding value calculated from the sound power level.

N.A.: Not available

13 DIMENSIONAL DRAWINGS

Data Book
 NX2-N-G06 0344 - 0808_202105_EN R454B

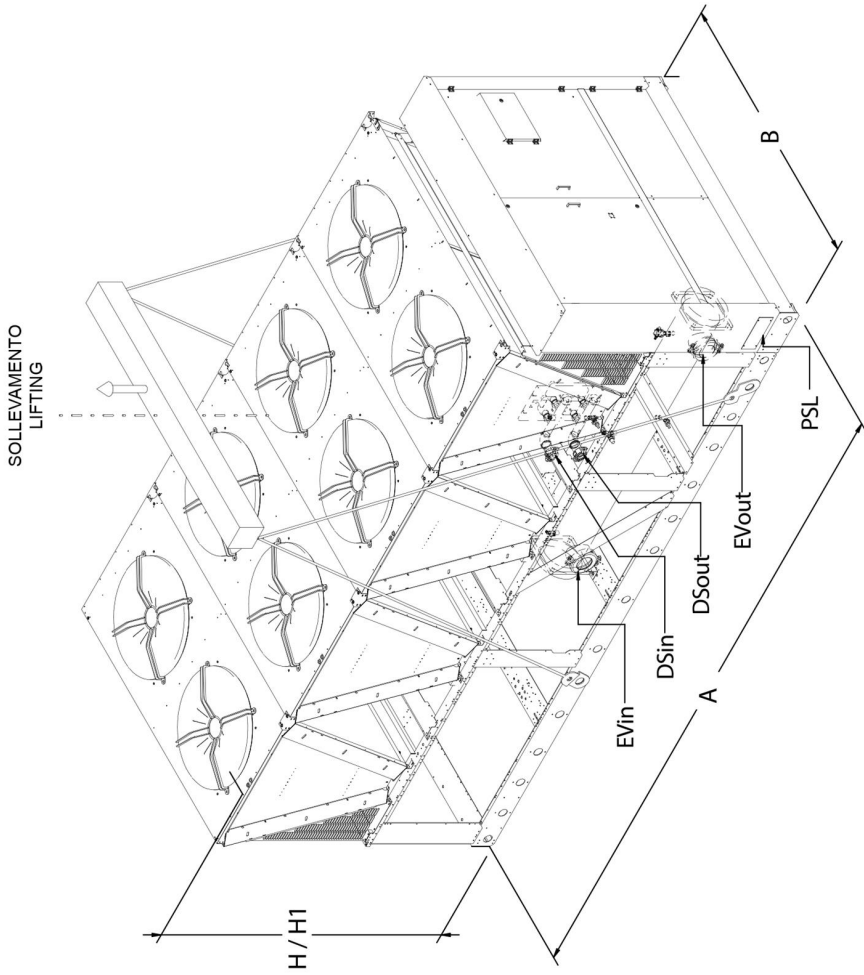

- | | |
|-------|--|
| EVin | Entrata acqua evaporatore
Evaporator water inlet |
| EYout | Uscita acqua evaporatore
Evaporator water outlet |
| DSin | Entrata acqua desurriscaldatore (solo per versione /D)
Desuperheater water inlet (only for "/D" version) |
| DSout | Uscita acqua desurriscaldatore (solo per versione /D)
Desuperheater water outlet (only for "/D" version) |
| PS | Ingresso linea di alimentazione elettrica (L=Sinistro, R=Destro)
Power supply cable inlet (L=Left, R=Right) |

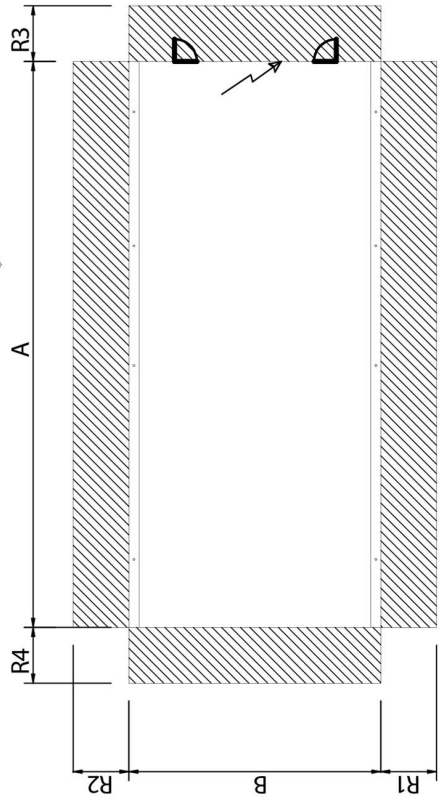
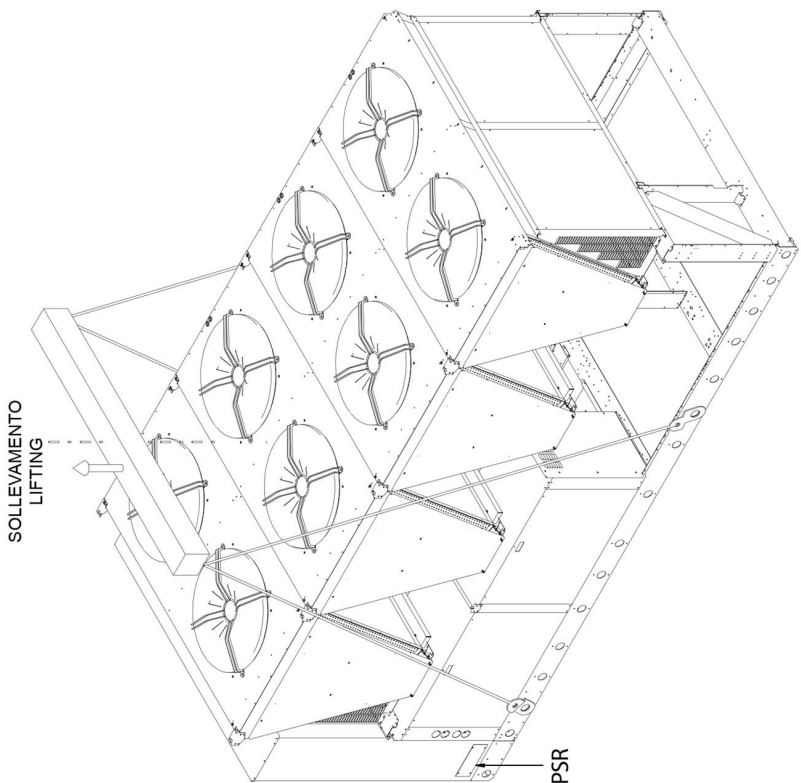

REMARKS: For installation purposes, please refer to the documentation sent after the purchase contract. This technical data should be considered as indicative. Mitsubishi Electric Hydronics & IT Cooling Systems S.p.A. may modify them at any moment. Data valid for standard units without any additional option.

DIMENSIONAL DRAWINGS

Data Book
NX2-N-G06 0344 - 0808_202105_EN R454B

[SI System]

SIZE	DIMENSIONS AND WEIGHTS				CLEARANCE				HEAT EXCHANGER USER SIDE		HEAT RECOVERY EX. USER SIDE	
	A	B	H	WEIGHT	R1	R2	R3	R4	IN/OUT		IN/OUT	
	[mm]	[mm]	[mm]	[kg]	[mm]	[mm]	[mm]	[mm]	TYPE	Ø	TYPE	Ø
NX2-N-G06 /K /0344	3905	2260	2450	3030	1500	2000	1500	1500	A	4"	-	-
NX2-N-G06 /K /0364	3905	2260	2450	3110	1500	2000	1500	1500	A	4"	-	-
NX2-N-G06 /K /0404	3905	2260	2450	3150	1500	2000	1500	1500	A	4"	-	-
NX2-N-G06 /K /0446	4515	2260	2450	4040	1500	2000	1500	1500	A	5"	-	-
NX2-N-G06 /K /0506	5690	2260	2450	4400	1500	2000	1500	1500	A	5"	-	-
NX2-N-G06 /K /0526	5690	2260	2450	4530	1500	2000	1500	1500	A	5"	-	-
NX2-N-G06 /K /0546	5690	2260	2450	4600	1500	2000	1500	1500	A	5"	-	-
NX2-N-G06 /D /K /0344	3905	2260	2450	3030	1500	2000	1500	1500	A	4"	A	2"
NX2-N-G06 /D /K /0364	3905	2260	2450	3110	1500	2000	1500	1500	A	4"	A	2"
NX2-N-G06 /D /K /0404	3905	2260	2450	3150	1500	2000	1500	1500	A	4"	A	2"
NX2-N-G06 /D /K /0446	4515	2260	2450	4040	1500	2000	1500	1500	A	5"	A	2" 1/2
NX2-N-G06 /D /K /0506	5690	2260	2450	4400	1500	2000	1500	1500	A	5"	A	2" 1/2
NX2-N-G06 /D /K /0526	5690	2260	2450	4530	1500	2000	1500	1500	A	5"	A	2" 1/2
NX2-N-G06 /D /K /0546	5690	2260	2450	4600	1500	2000	1500	1500	A	5"	A	2" 1/2
NX2-N-G06 /SL /0344	4515	2260	2450	3330	1500	2000	1500	1500	A	4"	-	-
NX2-N-G06 /SL /0364	5080	2260	2450	3460	1500	2000	1500	1500	A	4"	-	-
NX2-N-G06 /SL /0404	5080	2260	2450	3630	1500	2000	1500	1500	A	4"	-	-
NX2-N-G06 /SL /0446	5690	2260	2450	4640	1500	2000	1500	1500	A	5"	-	-
NX2-N-G06 /SL /0506	5690	2260	2450	4750	1500	2000	1500	1500	A	5"	-	-
NX2-N-G06 /SL /0526	6865	2260	2450	5050	1500	2000	1500	1500	A	5"	-	-
NX2-N-G06 /SL /0546	7430	2260	2450	5170	1500	2000	1500	1500	A	5"	-	-
NX2-N-G06 /D /SL /0344	4515	2260	2450	3330	1500	2000	1500	1500	A	4"	A	2"
NX2-N-G06 /D /SL /0364	5080	2260	2450	3460	1500	2000	1500	1500	A	4"	A	2"
NX2-N-G06 /D /SL /0404	5080	2260	2450	3630	1500	2000	1500	1500	A	4"	A	2"
NX2-N-G06 /D /SL /0446	5690	2260	2450	4640	1500	2000	1500	1500	A	5"	A	2" 1/2
NX2-N-G06 /D /SL /0506	5690	2260	2450	4750	1500	2000	1500	1500	A	5"	A	2" 1/2
NX2-N-G06 /D /SL /0526	6865	2260	2450	5050	1500	2000	1500	1500	A	5"	A	2" 1/2
NX2-N-G06 /D /SL /0546	7430	2260	2450	5170	1500	2000	1500	1500	A	5"	A	2" 1/2
NX2-N-G06 /A /0344	5080	2260	2450	3350	1500	2000	1500	1500	A	4"	-	-
NX2-N-G06 /A /0364	5080	2260	2450	3440	1500	2000	1500	1500	A	4"	-	-
NX2-N-G06 /A /0404	5080	2260	2450	3480	1500	2000	1500	1500	A	4"	-	-
NX2-N-G06 /A /0446	6255	2260	2450	4650	1500	2000	1500	1500	A	5"	-	-
NX2-N-G06 /A /0506	7430	2260	2450	4900	1500	2000	1500	1500	A	5"	-	-
NX2-N-G06 /A /0526	7430	2260	2450	5060	1500	2000	1500	1500	A	5"	-	-
NX2-N-G06 /A /0546	7430	2260	2450	5140	1500	2000	1500	1500	A	5"	-	-
NX2-N-G06 /A /0606	7430	2260	2450	5200	1500	2000	1500	1500	A	5"	-	-
NX2-N-G06 /A /0708	9780	2260	2450	6580	1500	2000	1500	1500	A	6"	-	-
NX2-N-G06 /A /0738	9780	2260	2450	6760	1500	2000	1500	1500	A	6"	-	-
NX2-N-G06 /A /0768	9780	2260	2450	6800	1500	2000	1500	1500	A	6"	-	-
NX2-N-G06 /A /0808	9780	2260	2450	6840	1500	2000	1500	1500	A	6"	-	-
NX2-N-G06 /D /A /0344	5080	2260	2450	3350	1500	2000	1500	1500	A	4"	A	2"
NX2-N-G06 /D /A /0364	5080	2260	2450	3440	1500	2000	1500	1500	A	4"	A	2"
NX2-N-G06 /D /A /0404	5080	2260	2450	3480	1500	2000	1500	1500	A	4"	A	2"
NX2-N-G06 /D /A /0446	6255	2260	2450	4650	1500	2000	1500	1500	A	5"	A	2" 1/2
NX2-N-G06 /D /A /0506	7430	2260	2450	4900	1500	2000	1500	1500	A	5"	A	2" 1/2
NX2-N-G06 /D /A /0526	7430	2260	2450	5060	1500	2000	1500	1500	A	5"	A	2" 1/2
NX2-N-G06 /D /A /0546	7430	2260	2450	5140	1500	2000	1500	1500	A	5"	A	2" 1/2

DIMENSIONAL DRAWINGS

Data Book

NX2-N-G06 0344 - 0808_202105_EN R454B

[SI System]

SIZE	DIMENSIONS AND WEIGHTS				CLEARANCE				HEAT EXCHANGER USER SIDE		HEAT RECOVERY EX. USER SIDE	
	A	B	H	WEIGHT	R1	R2	R3	R4	IN/OUT		IN/OUT	
	[mm]	[mm]	[mm]	[kg]	[mm]	[mm]	[mm]	[mm]	TYPE	Ø	TYPE	Ø
NX2-N-G06 /D /A /0606	7430	2260	2450	5200	1500	2000	1500	1500	A	5"	A	2" 1/2
NX2-N-G06 /D /A /0708	9780	2260	2450	6580	1500	2000	1500	1500	A	6"	A	2" 1/2
NX2-N-G06 /D /A /0738	9780	2260	2450	6760	1500	2000	1500	1500	A	6"	A	2" 1/2
NX2-N-G06 /D /A /0768	9780	2260	2450	6800	1500	2000	1500	1500	A	6"	A	2" 1/2
NX2-N-G06 /D /A /0808	9780	2260	2450	6840	1500	2000	1500	1500	A	6"	A	2" 1/2

13.2 Legend of pipe connections

[A]

TYPE = A
[A] - Grooved pipe

NOMINAL PIPE SIZE	PIPE OUTSIDE DIAMETER
∅ inches	∅ mm
3/4	26,7
1	33,7
1 1/4	42,4
1 1/2	48,3
2	60,3
2 1/2	76,1
3	88,9
3 1/2	101,6

NOMINAL PIPE SIZE	PIPE OUTSIDE DIAMETER
∅ inches	∅ mm
4	114,3
4 1/2	127,0
5	139,7
6	168,3
8	219,1
10	273,0
12	323,9
14	355,6

UNI ISO 228/13

Pipe threads where pressure-tight joints are not made on the threads - Designation, dimensions and tolerances

Used terminology:

G: Pipe threads where pressure-tight joints are not made on the threads

A: Close tolerance class for external pipe threads where pressure-tight joints are not made on the threads

B: Wider tolerance class for external pipe threads where pressure-tight joints are not made on the threads

Internal threads: G letter followed by thread mark (only tolerance class)

External threads: G letter followed by thread mark and by A letter for A class external threads or by B letter for B class external threads.

UNI EN 10226-1

Pipe threads where pressure-tight joints are made on the threads - Designation, dimensions and tolerances

Used terminology:

Rp: Internal cylindrical threads where pressure-tight joints are made on the threads

Rc: Internal conical threads where pressure-tight joints are made on the threads

R: External conical threads where pressure-tight joints are made on the threads

Internal cylindrical threads: R letter followed by p letter

Internal conical threads: R letter followed by c letter

External conical threads: R letter

DIMENSIONAL DRAWINGS**Data Book**
NX2-N-G06 0344 - 0808_202105_EN R454B**NOTE:**

Conventional diameter value [in inches] identifies short thread designation, based upon the relative standard.

All relative values are defined by standards.

As example, here below some values:

14.1 Hydronic groups

HYDRONIC MODULE

The units can be fitted with the hydronic module includes the main water circuit components, thus optimizing water circuit and electrical installation space, times and costs.

The built-in hydronic module is available as option with single or twin in-line pump, for achieving low head or high head, fixed or variable speed and with buffer tank.

The combination hydronic module + buffer tank is not available for size /K 0446.

The standard configuration of the units feature:

- terminals for external pumps control (relays + 0-10V signal)
- differential pressure switch (on heat exchanger)
- discharge valves on exchanger
- purge valve
- safety valve (10 bar)

For the hydronic modules with pumps, the factory-mounted components are:

- 1 or 2 pumps, 2 poles, low head or high head, fixed or variable speed (inverter)
- differential pressure switch (on heat exchanger)
- discharge valves on exchanger
- one-way valve (Clapet type for in-line pumps)
- purge valve
- safety valve (10 bar)

For the hydronic modules with pumps and buffer tank, the factory-mounted components are:

- 1 or 2 pumps, 2 poles, low head or high head, fixed or variable speed (inverter)
- buffer tank covered by a 20 mm thick of insulation lining in closed-cell reticulated foam.
- Buffer tank capacity: 600 l for sizes /K 0344, /K 0364, /K 0404 and /SL 0344, all with 2 pumps HH, and for size /K 0404 with 2 pumps LH.
- Buffer tank capacity: 700 l for sizes /K 0344, /K 0364, /K 0404 and /SL 0344, all with 1 pump HH or LH, and for sizes /K 0344, /K 0364 and /SL 0344 with 2 pumps LH.
- Buffer tank capacity 1000 l for all other sizes/versions.
- expansion tank (membrane made of EPDM) of 25 l of capacity (pre-charge: 1.5 bar) with 600 l and 700 l buffer tanks, 40 l of capacity (pre-charge: 1.5 bar) with 1000 l buffer tank
- differential pressure switch (on heat exchanger)
- discharge and suction valves
- One-way valve (Clapet type for in-line pumps)
- purge valve
- safety valve (6 bar)
- pressure gauge

Each of the components of the hydraulic group has been designed to optimise hydraulic and electrical installation space, time and costs.

The second pump operates in stand-by to the first.

The relative operating hours of the two pumps are balanced. In case the operating pump breaks down, the reserve pump is automatically enabled.

The electrical panel of the unit is protected with fuses and contactors with thermals cut-out.

Suction, volute and discharge of each pump and all the water pipes are covered with an insulation lining in closed-cell reticulated foam in PE, CFC and HCFC-free.

In units /K and /A with opt. acoustical enclosure, the hydronic group is protected by a self-ventilated enclosure, acoustically insulated by a 15 mm thick lining of polyester fibers (Fiberform).

IN-LINE PUMPS**Low or high head pumps**

Centrifugal pumps with in-line suction and delivery flanges, in single or twin versions. Pump body in cast iron and impeller in AISI 316L stainless steel or cast-iron, entirely laser technology welded. Mechanical seal with EPDM elastomers. Three-phase electric motor protected to IP55, insulation class F, suitable for continuous service.

OTHER COMPONENTS

The following components are excluded from the hydronic kit supply, but their use is mandatory for the correct unit and system operation.

These components are available as accessories and supplied loose, it shall be the customer responsibility to install them.

- Unit inlet water filter
- Unit outlet flow-switch

It is also recommended the use of the following components:

- Unit inlet and outlet pressure gauges
- Shut-off valves
- Flexible joints on piping

SPECIAL PUMPS

For pumps with different configurations, please contact our sales department.

14 HYDRONIC GROUP

Data Book

NX2-N-G06 0344 - 0808_202105_EN R454B

Possible configurations

PUMP GROUP	Versions		
	A	K	SL
U - 1 PUMP 2P LH (FIX SPEED)(4736)	X	X	X
U - 1 PUMP 2P HH (FIX SPEED)(4737)	X	X	X
U - 2 PUMPS 2P LH (FIX SPEED)(4741)	X	X	X
U - 2 PUMPS 2P HH (FIX SPEED)(4742)	X	X	X
U - 1 PUMP 2P LH (VAR SPEED)(4747)	X	X	X
U - 1 PUMP 2P HH (VAR SPEED)(4748)	X	X	X
U - 2 PUMPS 2P LH (VAR SPEED)(4752)	X	X	X
U - 2 PUMPS 2P HH (VAR SPEED)(4753)	X	X	X

HYDRONIC GROUP

Data Book
NX2-N-G06 0344 - 0808_202105_EN R454B

SCHEMA IDRAULICO CON 1-2 POMPE
 HYDRAULIC DIAGRAM WITH 1-2 PUMPS

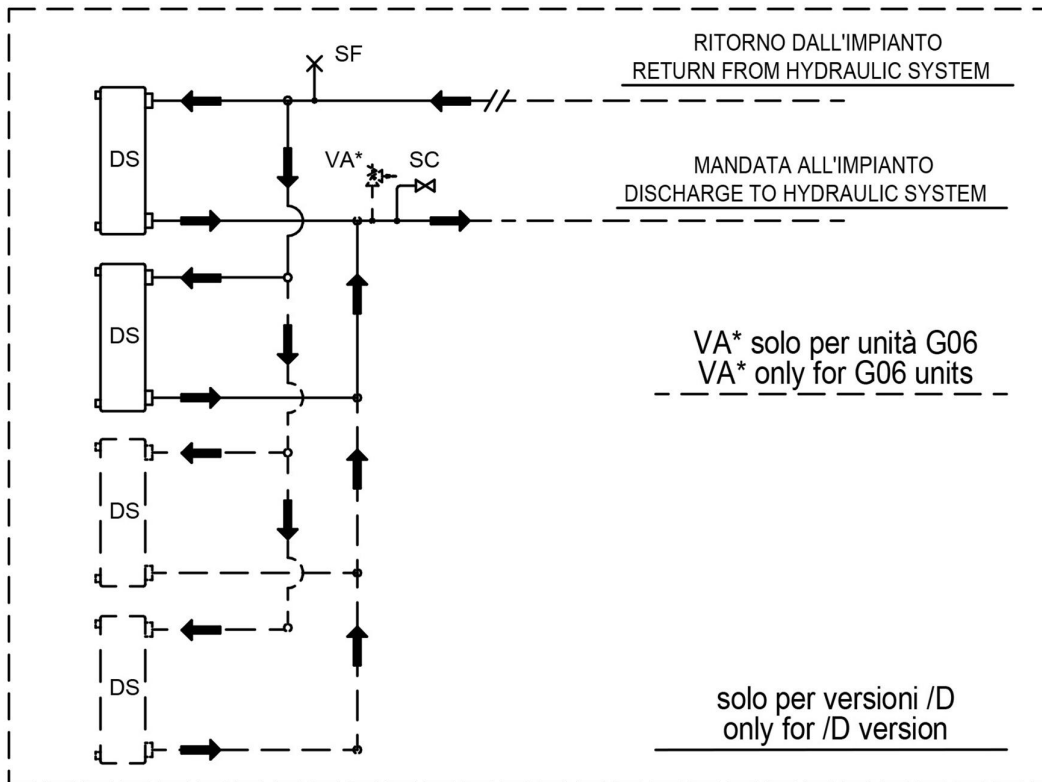
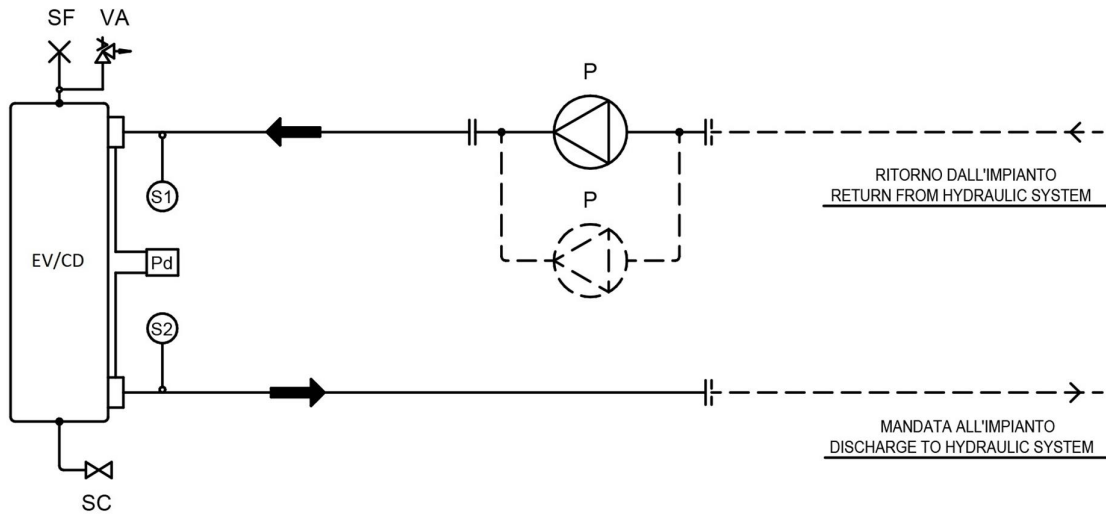

	LEGENDA (IT)	LEGEND (ENG)
EV/CD	Evaporatore\Condensatore	Evaporator\Condenser
DS	Desurriscaldatore (opzionale)	Desuperheater (optional)
P	Pompa dell'acqua	Water pump
Pd	Pressostato differenziale	Differential pressure switch
SC	Valvola di drenaggio dell'acqua	Water drain valve
SF	Valvola di sfianto dell'aria	Air vent valve
S_	Sonda di temperatura	Temperature probe
VA	Valvola sicurezza	Pressure relief valve

HYDRONIC GROUP

Data Book
 NX2-N-G06 0344 - 0808_202105_EN R454B

SCHEMA IDRAULICO CON 1-2 POMPE + ACCUMULO
 HYDRAULIC DIAGRAM WITH 1-2 PUMPS + BUFFER TANK

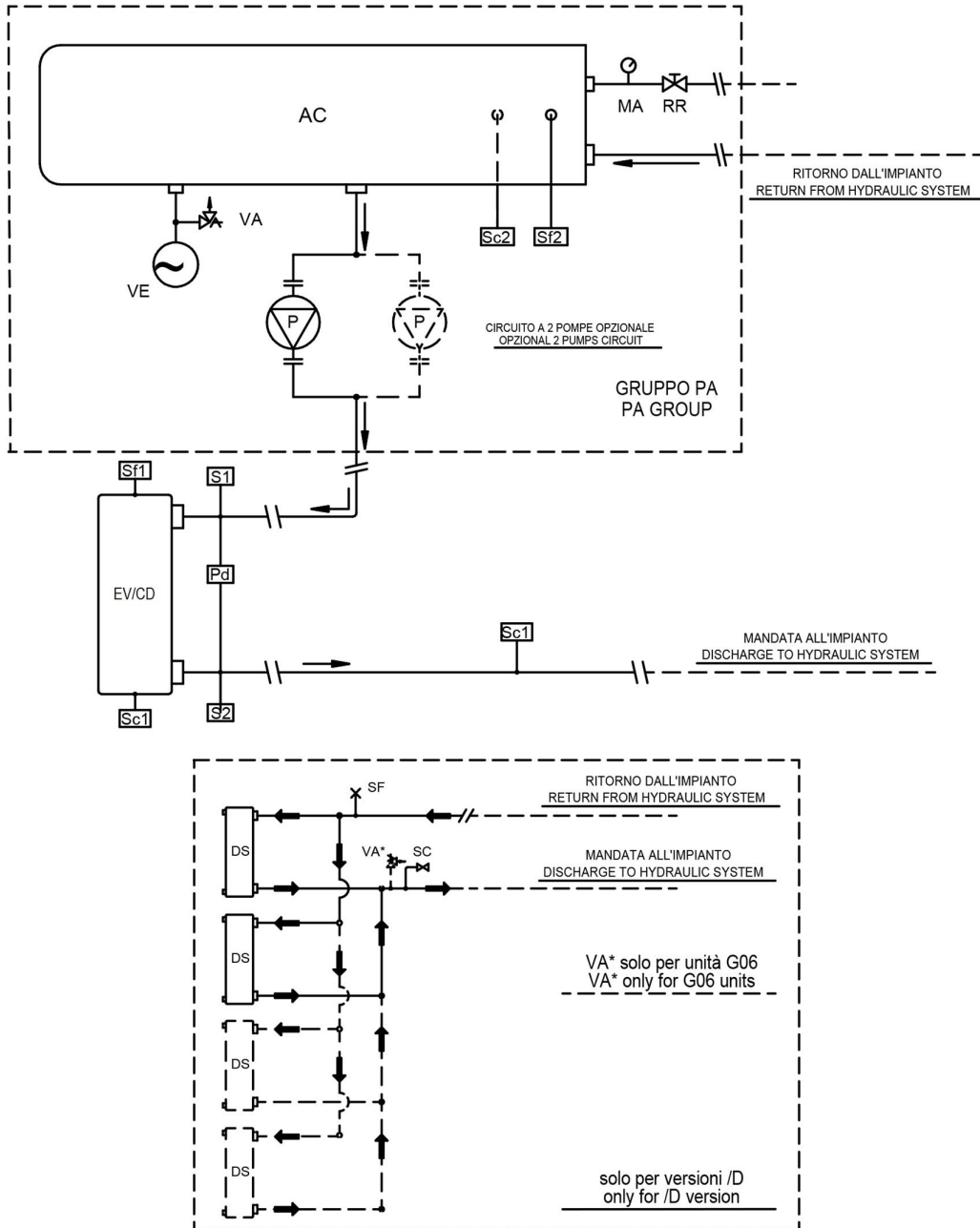

	LEGENDA (IT)	LEGEND (ENG)
AC	Accumulo	Water tank
EV/CD	Evaporatore/Condensatore	Evaporator/Condenser
DS	Desurriscaldatore (opzionale)	Desuperheater (optional)
MA	Manometro alta pressione	High pressure gauge
P	Pompa dell'acqua	Water pump
Pd	Pressostato differenziale	Differential pressure switch
RR	Rubinetto reintegro	Filling valve
S_	Sonda di temperatura	Temperature probe
SC	Valvola di drenaggio dell'acqua	Water drain valve
SF	Valvola di sfiato dell'aria	Air vent valve
VA	Valvola sicurezza	Pressure relief valve
VE	Vaso di espansione acqua	Expansion vessel

HYDRONIC GROUP

Data Book

NX2-N-G06 0344 - 0808_202105_EN R454B

Hydronic kit positioning

	Version	U - 1 PUMP 2P LH (FIX SPEED) (4736)				U - 1 PUMP 2P HH (FIX SPEED) (4737)				U - 2 PUMPS 2P LH (FIX SPEED) (4741)				U - 2 PUMPS 2P HH (FIX SPEED) (4742)			
		extra L [mm]	extra W [mm]	extra H [mm]	extra WGT [kg]	extra L [mm]	extra W [mm]	extra H [mm]	extra WGT [kg]	extra L [mm]	extra W [mm]	extra H [mm]	extra WGT [kg]	extra L [mm]	extra W [mm]	extra H [mm]	extra WGT [kg]
0344	A	/	/	/	240	/	/	/	240	/	/	/	240	/	/	/	240
	K	/	/	/	230	/	/	/	230	/	/	/	230	/	/	/	230
	SL	/	/	/	300	/	/	/	300	/	/	/	300	/	/	/	300
0364	A	/	/	/	240	/	/	/	240	/	/	/	240	/	/	/	240
	K	/	/	/	230	/	/	/	230	/	/	/	230	/	/	/	230
	SL	/	/	/	300	/	/	/	300	/	/	/	300	/	/	/	300
0404	A	/	/	/	240	/	/	/	240	/	/	/	240	/	/	/	240
	K	/	/	/	230	/	/	/	230	/	/	/	230	/	/	/	230
	SL	/	/	/	290	/	/	/	290	/	/	/	290	/	/	/	290
0446	A	/	/	/	290	/	/	/	290	/	/	/	290	/	/	/	290
	K	/	/	/	250	/	/	/	250	/	/	/	250	/	/	/	250
	SL	/	/	/	320	/	/	/	320	/	/	/	320	/	/	/	320
0506	A	/	/	/	340	/	/	/	340	/	/	/	340	/	/	/	340
	K	/	/	/	330	/	/	/	330	/	/	/	330	/	/	/	330
	SL	/	/	/	390	/	/	/	390	/	/	/	390	/	/	/	390
0526	A	/	/	/	340	/	/	/	340	/	/	/	340	/	/	/	340
	K	/	/	/	330	/	/	/	330	/	/	/	330	/	/	/	330
	SL	/	/	/	400	/	/	/	400	/	/	/	400	/	/	/	400
0546	A	/	/	/	370	/	/	/	370	/	/	/	370	/	/	/	370
	K	/	/	/	350	/	/	/	350	/	/	/	350	/	/	/	350
	SL	/	/	/	420	/	/	/	420	/	/	/	420	/	/	/	420
0606	A	/	/	/	450	/	/	/	450	/	/	/	450	/	/	/	450
0708	A	/	/	/	470	/	/	/	470	/	/	/	470	/	/	/	470
0738	A	/	/	/	470	/	/	/	470	/	/	/	470	/	/	/	470
0768	A	/	/	/	470	/	/	/	470	/	/	/	470	/	/	/	470
0808	A	/	/	/	570	/	/	/	570	/	/	/	570	/	/	/	570

extra L	Unit's extra length
extra W	Unit's extra operating width (NOT to be considered for transport)
extra H	Unit's extra height
extra WGT	Unit's extra weight (pumps and piping)
U - 1 PUMP 2P LH (FIX SPEED)	U - 1 PUMP 2P LH (FIX SPEED)
U - 1 PUMP 2P HH (FIX SPEED)	U - 1 PUMP 2P HH (FIX SPEED)
U - 2 PUMPS 2P LH (FIX SPEED)	U - 2 PUMPS 2P LH (FIX SPEED)
U - 2 PUMPS 2P HH (FIX SPEED)	U - 2 PUMPS 2P HH (FIX SPEED)
-	Not available

HYDRONIC GROUP

Data Book
NX2-N-G06 0344 - 0808_202105_EN R454B

Hydronic kit positioning

	Version	U - 1 PUMP 2P LH (VAR SPEED) (4747)				U - 1 PUMP 2P HH (VAR SPEED) (4748)				U - 2 PUMPS 2P LH (VAR SPEED) (4752)				U - 2 PUMPS 2P HH (VAR SPEED) (4753)			
		extra L [mm]	extra W [mm]	extra H [mm]	extra WGT [kg]	extra L [mm]	extra W [mm]	extra H [mm]	extra WGT [kg]	extra L [mm]	extra W [mm]	extra H [mm]	extra WGT [kg]	extra L [mm]	extra W [mm]	extra H [mm]	extra WGT [kg]
0344	A	/	/	/	240	/	/	/	240	/	/	/	240	/	/	/	240
	K	/	/	/	230	/	/	/	230	/	/	/	230	/	/	/	230
	SL	/	/	/	300	/	/	/	300	/	/	/	300	/	/	/	300
0364	A	/	/	/	240	/	/	/	240	/	/	/	240	/	/	/	240
	K	/	/	/	230	/	/	/	230	/	/	/	230	/	/	/	230
	SL	/	/	/	300	/	/	/	300	/	/	/	300	/	/	/	300
0404	A	/	/	/	240	/	/	/	240	/	/	/	240	/	/	/	240
	K	/	/	/	230	/	/	/	230	/	/	/	230	/	/	/	230
	SL	/	/	/	290	/	/	/	290	/	/	/	290	/	/	/	290
0446	A	/	/	/	290	/	/	/	290	/	/	/	290	/	/	/	290
	K	/	/	/	250	/	/	/	250	/	/	/	250	/	/	/	250
	SL	/	/	/	320	/	/	/	320	/	/	/	320	/	/	/	320
0506	A	/	/	/	340	/	/	/	340	/	/	/	340	/	/	/	340
	K	/	/	/	330	/	/	/	330	/	/	/	330	/	/	/	330
	SL	/	/	/	390	/	/	/	390	/	/	/	390	/	/	/	390
0526	A	/	/	/	340	/	/	/	340	/	/	/	340	/	/	/	340
	K	/	/	/	330	/	/	/	330	/	/	/	330	/	/	/	330
	SL	/	/	/	400	/	/	/	400	/	/	/	400	/	/	/	400
0546	A	/	/	/	370	/	/	/	370	/	/	/	370	/	/	/	370
	K	/	/	/	350	/	/	/	350	/	/	/	350	/	/	/	350
	SL	/	/	/	420	/	/	/	420	/	/	/	420	/	/	/	420
0606	A	/	/	/	450	/	/	/	450	/	/	/	450	/	/	/	450
0708	A	/	/	/	470	/	/	/	470	/	/	/	470	/	/	/	470
0738	A	/	/	/	470	/	/	/	470	/	/	/	470	/	/	/	470
0768	A	/	/	/	470	/	/	/	470	/	/	/	470	/	/	/	470
0808	A	/	/	/	570	/	/	/	570	/	/	/	570	/	/	/	570

extra L	Unit's extra length
extra W	Unit's extra operating width (NOT to be considered for transport)
extra H	Unit's extra height
extra WGT	Unit's extra weight (pumps and piping)
U - 1 PUMP 2P LH (VAR SPEED)	U - 1 PUMP 2P LH (VAR SPEED)
U - 1 PUMP 2P HH (VAR SPEED)	U - 1 PUMP 2P HH (VAR SPEED)
U - 2 PUMPS 2P LH (VAR SPEED)	U - 2 PUMPS 2P LH (VAR SPEED)
U - 2 PUMPS 2P HH (VAR SPEED)	U - 2 PUMPS 2P HH (VAR SPEED)
-	Not available

HYDRONIC GROUP

Data Book
NX2-N-G06 0344 - 0808_202105_EN R454B

HEAT EXCHANGER USER SIDE - U - 1 PUMP 2P HH (FIX SPEED)

SIZE		CH		HP		PUMP				CH	HP													
		Pfgross	Qfgross	Ptgross	Qcdgross	Curve	Model	N.	F.L.A.	F.L.I.	HU	HU												
		[kW] (1)	[l/s] (1)	[kW] (1)	[l/s] (1)			Pole	[A]	[kW]	[kPa]	[kPa]												
0344	A	345,3	16,51	376,3	18,17	A1	LNEE 80-160/75/2	2	14	7,500	194	176												
	K	334,7	16,01	364,7	17,60						199	182												
	SL	316,4	15,13	362,0	17,47						207	183												
0364	A	361,5	17,29	397,2	19,17	A2					LNEE 80-160/75/2	2	14	7,500	202	184								
	K	355,0	16,98	386,5	18,66										204	189								
	SL	336,8	16,11	379,2	18,30										212	192								
0404	A	399,8	19,12	426,7	20,60	A3									LNEE 80-160/75/2	2	14	7,500	184	169				
	K	382,4	18,29	414,9	20,03														192	175				
	SL	370,6	17,72	420,1	20,28														198	173				
0446	A	446,5	21,35	492,5	23,77	A4													LNEE 80-160/75/2	2	14	7,500	175	150
	K	430,6	20,59	469,4	22,66																		182	162
	SL	409,4	19,58	470,8	22,73																		192	161
0506	A	500,0	23,91	531,0	25,63	B1	LNEE 80-160/110/2	2	20	11,00													229	210
	K	475,7	22,75	512,7	24,75																		241	220
	SL	444,0	21,23	511,1	24,67																		255	221
0526	A	525,8	25,14	573,6	27,69	B2					LNEE 80-160/110/2	2	20	11,00									235	210
	K	516,4	24,70	560,2	27,04																		240	217
	SL	486,6	23,27	552,0	26,65																		252	221
0546	A	543,5	25,99	596,0	28,77	B3									LNEE 80-160/110/2	2	20	11,00					227	198
	K	533,6	25,52	579,9	27,99																		232	207
	SL	506,1	24,20	568,8	27,46																		244	212
0606	A	599,3	28,66	640,0	30,89	B4													LNEE 100-160/185/2	2	33	18,50	207	183
0708	A	696,6	33,31	752,7	36,34	C1																	264	245
0738	A	724,8	34,66	794,7	38,36	C2																	270	249
0768	A	762,0	36,44	825,4	39,84	C3	260	240																
0808	A	799,2	38,22	853,3	41,19	C4	250	231																

(1) Values refer to nominal conditions
 CH Cooling mode
 HP HP mode
 Pf Cooling capacity unit (Cooling mode)
 Pt Heating capacity unit (Heating mode)

Q Plant (side) exchanger water flow
 F.L.I. Pump power input
 F.L.A. Pump running current
 HU Pump residual pressure head (Units with hydronic group without mains filter)

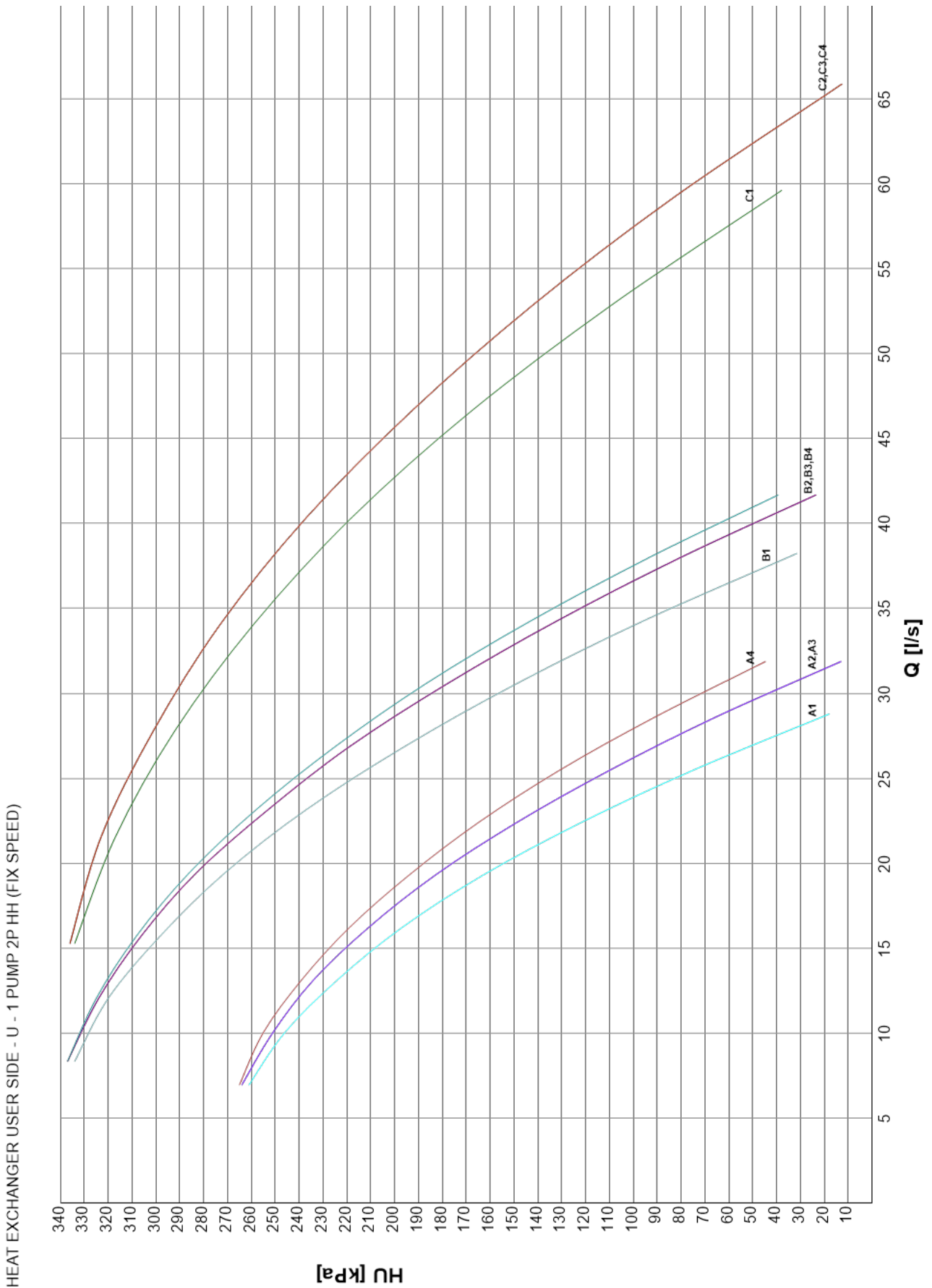

HYDRONIC GROUP

Data Book

NX2-N-G06 0344 - 0808_202105_EN R454B

HEAT EXCHANGER USER SIDE - U - 1 PUMP 2P HH (VAR SPEED)

SIZE		CH		HP		PUMP				CH	HP													
		Pfgross	Qfgross	Ptgross	Qcdgross	Curve	Model	N.	F.L.A.	F.L.I.	HU	HU												
		[kW] (1)	[l/s] (1)	[kW] (1)	[l/s] (1)			Pole	[A]	[kW]	[kPa]	[kPa]												
0344	A	345,3	16,51	376,3	18,17	A1	LNEE 80-160/75/2	2	14	7,500	194	176												
	K	334,7	16,01	364,7	17,60						199	182												
	SL	316,4	15,13	362,0	17,47						207	183												
0364	A	361,5	17,29	397,2	19,17	A2					LNEE 80-160/75/2	2	14	7,500	202	184								
	K	355,0	16,98	386,5	18,66										204	189								
	SL	336,8	16,11	379,2	18,30										212	192								
0404	A	399,8	19,12	426,7	20,60	A3									LNEE 80-160/75/2	2	14	7,500	184	169				
	K	382,4	18,29	414,9	20,03														192	175				
	SL	370,6	17,72	420,1	20,28														198	173				
0446	A	446,5	21,35	492,5	23,77	A4													LNEE 80-160/75/2	2	14	7,500	175	150
	K	430,6	20,59	469,4	22,66																		182	162
	SL	409,4	19,58	470,8	22,73																		192	161
0506	A	500,0	23,91	531,0	25,63	B1	LNEE 80-160/110/2	2	20	11,00													229	210
	K	475,7	22,75	512,7	24,75																		241	220
	SL	444,0	21,23	511,1	24,67																		255	221
0526	A	525,8	25,14	573,6	27,69	B2					LNEE 80-160/110/2	2	20	11,00									235	210
	K	516,4	24,70	560,2	27,04																		240	217
	SL	486,6	23,27	552,0	26,65																		252	221
0546	A	543,5	25,99	596,0	28,77	B3									LNEE 80-160/110/2	2	20	11,00					227	198
	K	533,6	25,52	579,9	27,99																		232	207
	SL	506,1	24,20	568,8	27,46																		244	212
0606	A	599,3	28,66	640,0	30,89	B4													LNEE 100-160/185/2	2	33	18,50	207	183
0708	A	696,6	33,31	752,7	36,34	C1																	264	245
0738	A	724,8	34,66	794,7	38,36	C2																	270	249
0768	A	762,0	36,44	825,4	39,84	C3	260	240																
0808	A	799,2	38,22	853,3	41,19	C4	250	231																

(1) Values refer to nominal conditions

CH Cooling mode

HP HP mode

Pf Cooling capacity unit (Cooling mode)

Pt Heating capacity unit (Heating mode)

Q Plant (side) exchanger water flow

F.L.I. Pump power input

F.L.A. Pump running current

HU Pump residual pressure head (Units with hydronic group without mains filter)

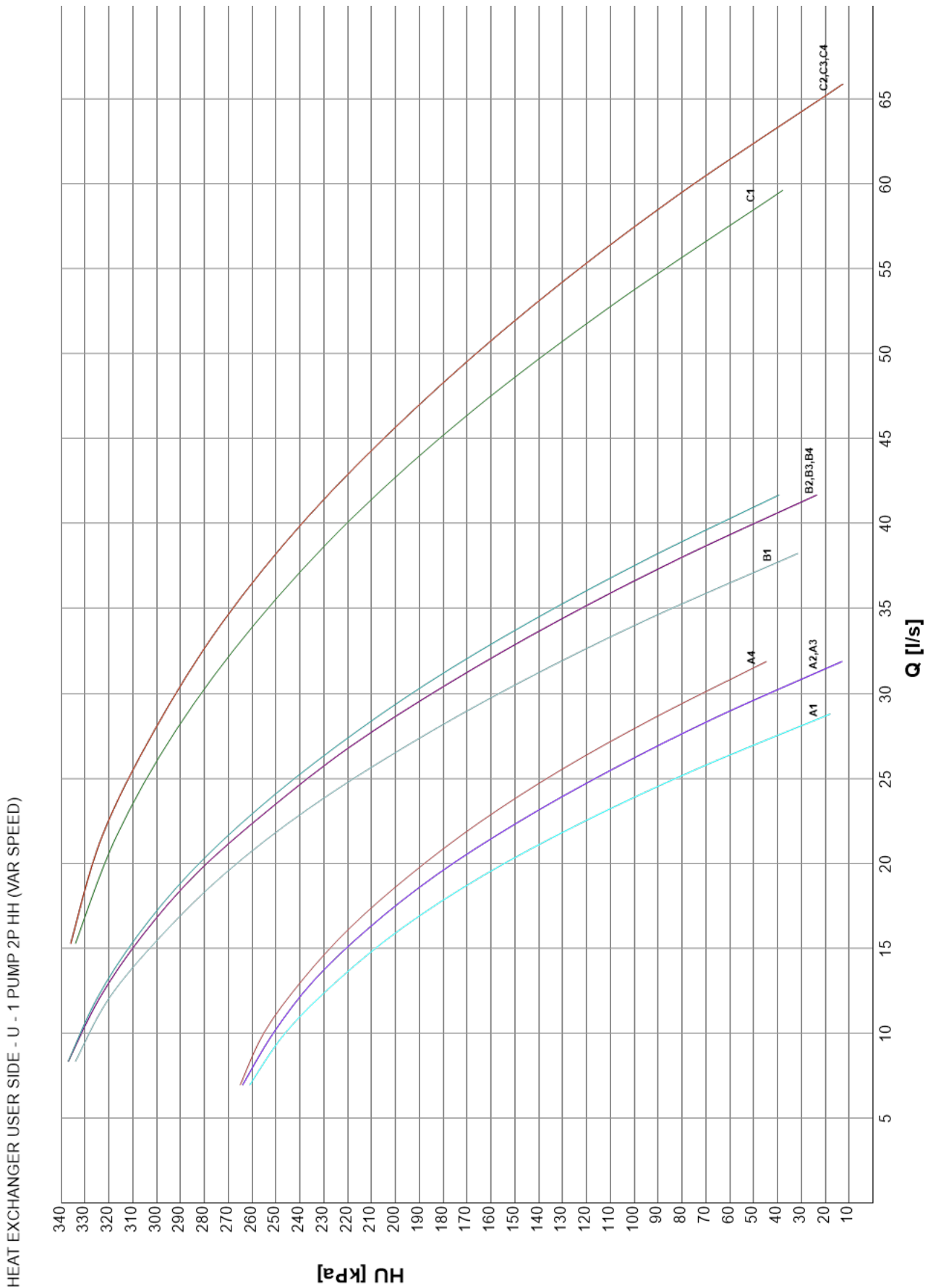

HYDRONIC GROUP

Data Book
 NX2-N-G06 0344 - 0808_202105_EN R454B

HEAT EXCHANGER USER SIDE - U - 1 PUMP 2P LH (FIX SPEED)

SIZE		CH		HP		PUMP				CH	HP	
		Pfgross	Qfgross	Ptgross	Qcdgross	Curve	Model	N.	F.L.A.	F.L.I.	HU	HU
		[kW] (1)	[l/s] (1)	[kW] (1)	[l/s] (1)			Pole	[A]	[kW]	[kPa]	[kPa]
0344	A	345,3	16,51	376,3	18,17	A1	LNEE 65-125/40/2	2	8	4,000	99,0	69,1
	K	334,7	16,01	364,7	17,60						107	79,7
	SL	316,4	15,13	362,0	17,47						121	82,1
0364	A	361,5	17,29	397,2	19,17	B1	LNEE 65-125/55/2	2	11	5,500	163	134
	K	355,0	16,98	386,5	18,66						167	142
	SL	336,8	16,11	379,2	18,30						178	148
0404	A	399,8	19,12	426,7	20,60	B2	LNEE 65-125/55/2	2	11	5,500	135	110
	K	382,4	18,29	414,9	20,03						148	120
	SL	370,6	17,72	420,1	20,28						156	115
0446	A	446,5	21,35	492,5	23,77	B3	LNEE 65-125/75/2	2	14	7,500	110	64,5
	K	430,6	20,59	469,4	22,66						123	86,3
	SL	409,4	19,58	470,8	22,73						139	85,0
0506	A	500,0	23,91	531,0	25,63	C1	LNEE 65-125/75/2	2	14	7,500	112	77,7
	K	475,7	22,75	512,7	24,75						134	95,7
	SL	444,0	21,23	511,1	24,67						159	97,3
0526	A	525,8	25,14	573,6	27,69	D1	LNEE 80-160/75/2	2	14	7,500	154	127
	K	516,4	24,70	560,2	27,04						158	134
	SL	486,6	23,27	552,0	26,65						172	138
0546	A	543,5	25,99	596,0	28,77	D2	LNEE 80-160/75/2	2	14	7,500	145	114
	K	533,6	25,52	579,9	27,99						150	123
	SL	506,1	24,20	568,8	27,46						163	129
0606	A	599,3	28,66	640,0	30,89	E1	LNES 100-250/75/4	4	14	7,500	111	94,7
0708	A	696,6	33,31	752,7	36,34	F1	LNEE 100-160/110/2	2	20	11,00	159	138
0738	A	724,8	34,66	794,7	38,36	F2					164	140
0768	A	762,0	36,44	825,4	39,84	F3					153	130
0808	A	799,2	38,22	853,3	41,19	F4					141	120

(1) Values refer to nominal conditions
 CH Cooling mode
 HP HP mode
 Pf Cooling capacity unit (Cooling mode)
 Pt Heating capacity unit (Heating mode)

Q Plant (side) exchanger water flow
 F.L.I. Pump power input
 F.L.A. Pump running current
 HU Pump residual pressure head (Units with hydronic group without mains filter)

HEAT EXCHANGER USER SIDE - U - 1 PUMP 2P LH (FIX SPEED)

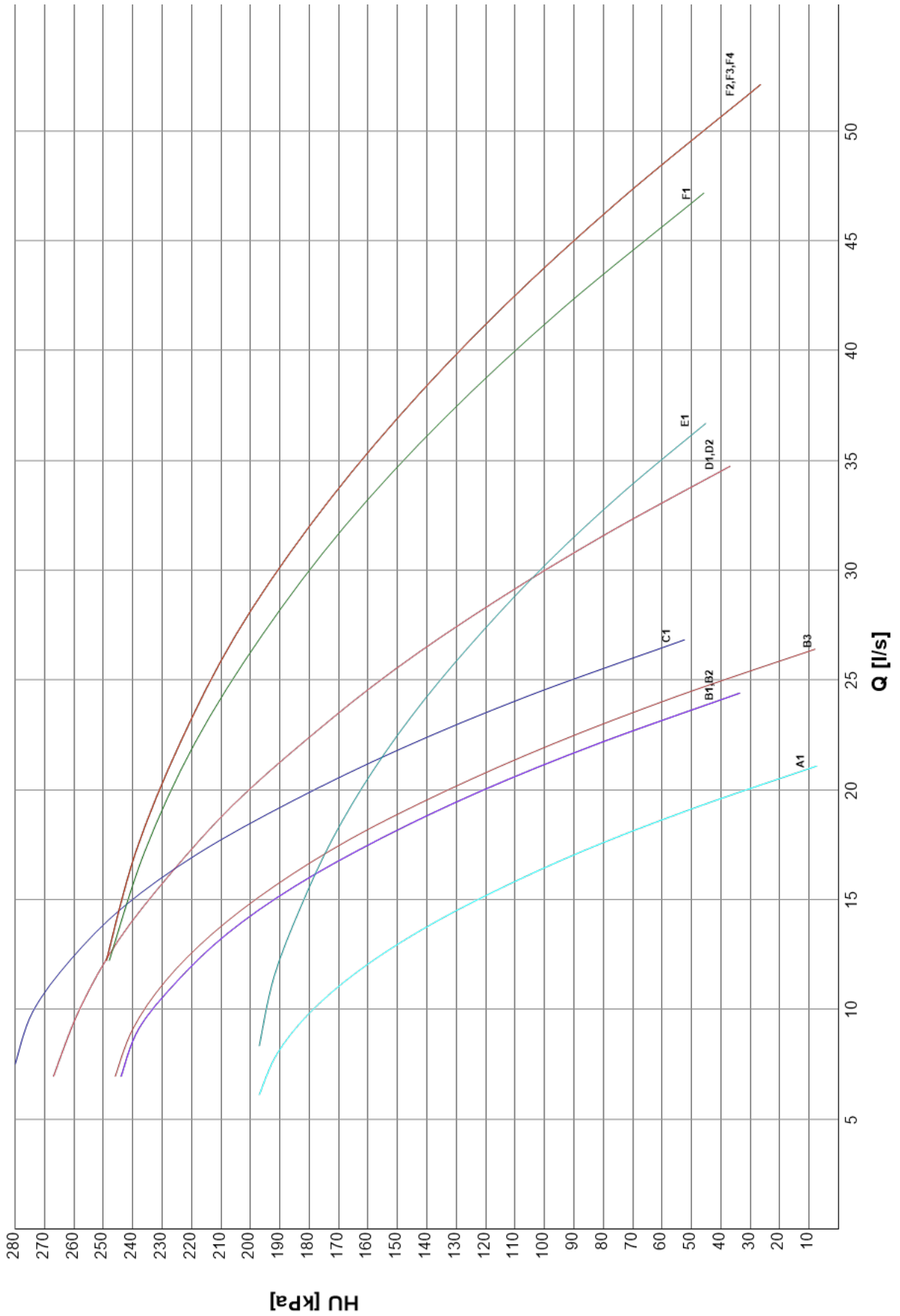

HYDRONIC GROUP

Data Book

NX2-N-G06 0344 - 0808_202105_EN R454B

HEAT EXCHANGER USER SIDE - U - 1 PUMP 2P LH (VAR SPEED)

SIZE		CH		HP		PUMP				CH	HP	
		Pfgross	Qfgross	Ptgross	Qcdgross	Curve	Model	N.	F.L.A.	F.L.I.	HU	HU
		[kW] (1)	[l/s] (1)	[kW] (1)	[l/s] (1)			Pole	[A]	[kW]	[kPa]	[kPa]
0344	A	345,3	16,51	376,3	18,17	A1	LNEE 65-125/40/2	2	8	4,000	99,0	69,1
	K	334,7	16,01	364,7	17,60						107	79,7
	SL	316,4	15,13	362,0	17,47						121	82,1
0364	A	361,5	17,29	397,2	19,17	B1	LNEE 65-125/55/2	2	11	5,500	163	134
	K	355,0	16,98	386,5	18,66						167	142
	SL	336,8	16,11	379,2	18,30						178	148
0404	A	399,8	19,12	426,7	20,60	B2	LNEE 65-125/55/2	2	11	5,500	135	110
	K	382,4	18,29	414,9	20,03						148	120
	SL	370,6	17,72	420,1	20,28						156	115
0446	A	446,5	21,35	492,5	23,77	B3	LNEE 65-125/75/2	2	14	7,500	110	64,5
	K	430,6	20,59	469,4	22,66						123	86,3
	SL	409,4	19,58	470,8	22,73						139	85,0
0506	A	500,0	23,91	531,0	25,63	C1	LNEE 65-125/75/2	2	14	7,500	112	77,7
	K	475,7	22,75	512,7	24,75						134	95,7
	SL	444,0	21,23	511,1	24,67						159	97,3
0526	A	525,8	25,14	573,6	27,69	D1	LNEE 80-160/75/2	2	14	7,500	154	127
	K	516,4	24,70	560,2	27,04						158	134
	SL	486,6	23,27	552,0	26,65						172	138
0546	A	543,5	25,99	596,0	28,77	D2	LNEE 80-160/75/2	2	14	7,500	145	114
	K	533,6	25,52	579,9	27,99						150	123
	SL	506,1	24,20	568,8	27,46						163	129
0606	A	599,3	28,66	640,0	30,89	E1	LNES 100-250/75/4	4	14	7,500	111	94,7
0708	A	696,6	33,31	752,7	36,34	F1	LNEE 100-160/110/2	2	20	11,00	159	138
0738	A	724,8	34,66	794,7	38,36	F2					164	140
0768	A	762,0	36,44	825,4	39,84	F3					153	130
0808	A	799,2	38,22	853,3	41,19	F4					141	120

(1) Values refer to nominal conditions

CH Cooling mode

HP HP mode

Pf Cooling capacity unit (Cooling mode)

Pt Heating capacity unit (Heating mode)

Q Plant (side) exchanger water flow

F.L.I. Pump power input

F.L.A. Pump running current

HU Pump residual pressure head (Units with hydronic group without mains filter)

HEAT EXCHANGER USER SIDE - U - 1 PUMP 2P LH (VAR SPEED)

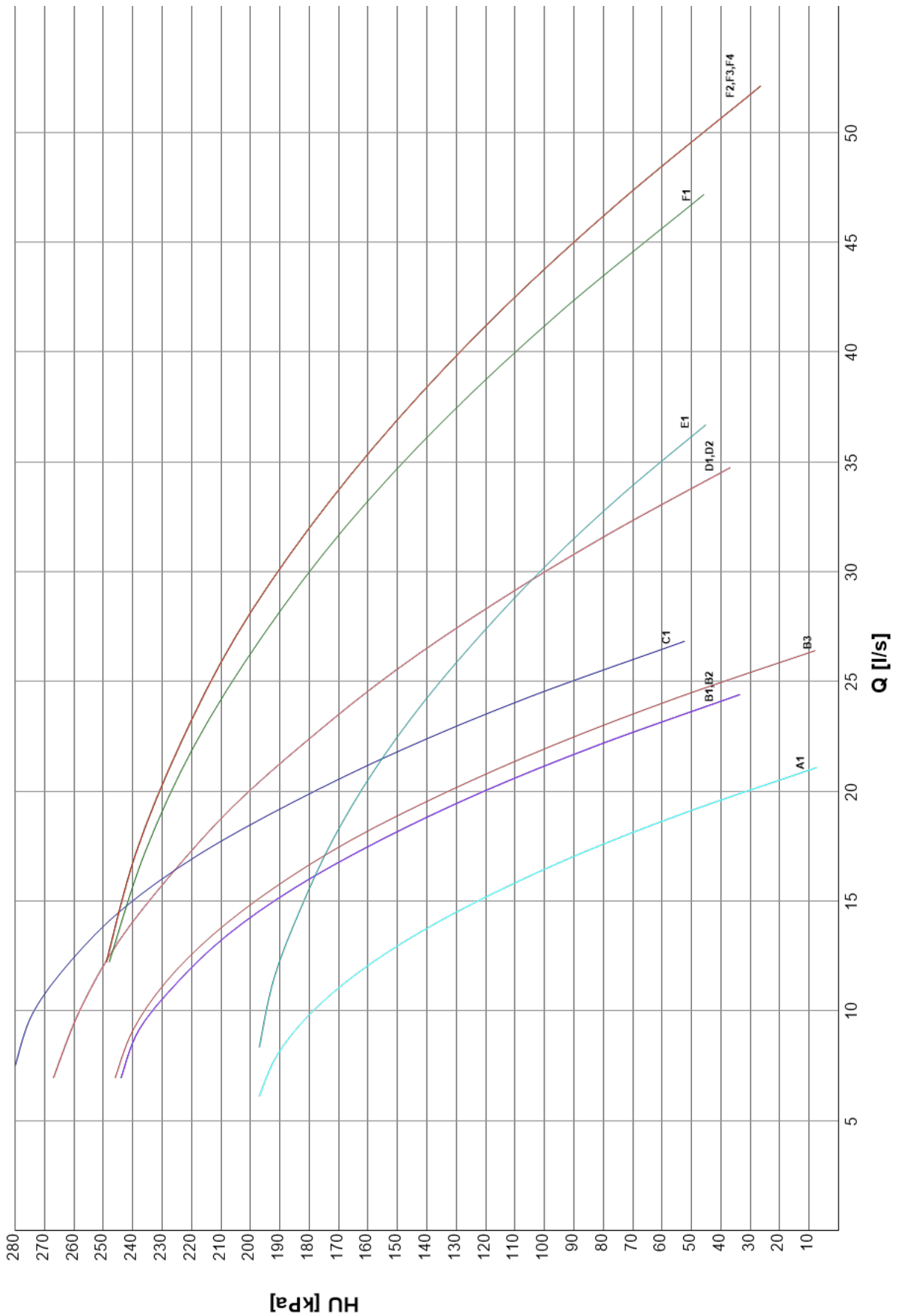

HYDRONIC GROUP

Data Book

NX2-N-G06 0344 - 0808_202105_EN R454B

HEAT EXCHANGER USER SIDE - U - 2 PUMPS 2P HH (FIX SPEED)

SIZE		CH		HP		PUMP				CH	HP		
		Pfgross	Qfgross	Ptgross	Qcdgross	Curve	Model	N.	F.L.A.	F.L.I.	HU	HU	
		[kW] (1)	[l/s] (1)	[kW] (1)	[l/s] (1)			Pole	[A]	[kW]	[kPa]	[kPa]	
0344	A	345,3	16,51	376,3	18,17	A1	LNTE 80-160/75/2	2	14	7,500	202	184	
	K	334,7	16,01	364,7	17,60						207	190	
	SL	316,4	15,13	362,0	17,47						215	192	
0364	A	361,5	17,29	397,2	19,17	A2					210	192	
	K	355,0	16,98	386,5	18,66						213	197	
	SL	336,8	16,11	379,2	18,30						220	201	
0404	A	399,8	19,12	426,7	20,60	A3		193	177				
	K	382,4	18,29	414,9	20,03			201	183				
	SL	370,6	17,72	420,1	20,28			206	180				
0446	A	446,5	21,35	492,5	23,77	B1		LNTE 80-160/92/2	2	17	9,200	210	184
	K	430,6	20,59	469,4	22,66							217	196
	SL	409,4	19,58	470,8	22,73							227	196
0506	A	500,0	23,91	531,0	25,63	C1	LNTE 80-160/110/2		2	20	11,00	221	201
	K	475,7	22,75	512,7	24,75							233	212
	SL	444,0	21,23	511,1	24,67							248	213
0526	A	525,8	25,14	573,6	27,69	C2		227				200	
	K	516,4	24,70	560,2	27,04			231				207	
	SL	486,6	23,27	552,0	26,65			245				211	
0546	A	543,5	25,99	596,0	28,77	C3		218	187				
	K	533,6	25,52	579,9	27,99			223	196				
	SL	506,1	24,20	568,8	27,46			236	202				
0606	A	599,3	28,66	640,0	30,89	D1		LNTE 100-160/150/2	2	27	15,00	222	206
0708	A	696,6	33,31	752,7	36,34	E1		LNTE 100-160/185/2	2	33	18,50	257	237
0738	A	724,8	34,66	794,7	38,36	E2						262	240
0768	A	762,0	36,44	825,4	39,84	E3	252					230	
0808	A	799,2	38,22	853,3	41,19	E4	241					220	

(1) Values refer to nominal conditions

CH Cooling mode

HP HP mode

Pf Cooling capacity unit (Cooling mode)

Pt Heating capacity unit (Heating mode)

Q Plant (side) exchanger water flow

F.L.I. Pump power input

F.L.A. Pump running current

HU Pump residual pressure head (Units with hydronic group without mains filter)

HEAT EXCHANGER USER SIDE - U - 2 PUMPS 2P HH (FIX SPEED)

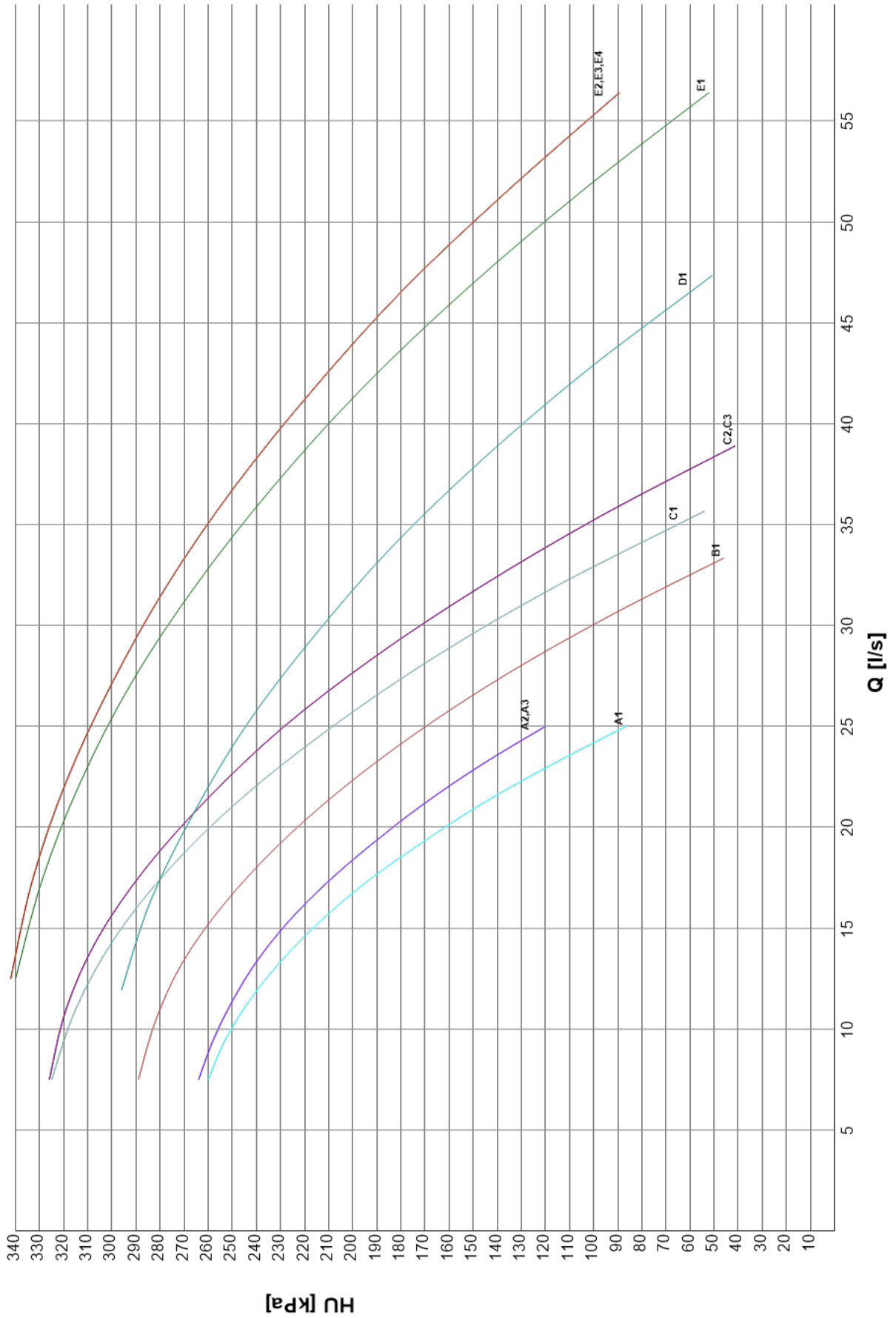

HYDRONIC GROUP

Data Book
NX2-N-G06 0344 - 0808_202105_EN R454B

HEAT EXCHANGER USER SIDE - U - 2 PUMPS 2P HH (VAR SPEED)

SIZE		CH		HP		PUMP				CH	HP	
		Pfgross	Qfgross	Ptgross	Qcdgross	Curve	Model	N.	F.L.A.	F.L.I.	HU	HU
		[kW] (1)	[l/s] (1)	[kW] (1)	[l/s] (1)			Pole	[A]	[kW]	[kPa]	[kPa]
0344	A	345,3	16,51	376,3	18,17	A1	LNTE 80-160/75/2	2	14	7,500	202	184
	K	334,7	16,01	364,7	17,60						207	190
	SL	316,4	15,13	362,0	17,47						215	192
0364	A	361,5	17,29	397,2	19,17	A2					210	192
	K	355,0	16,98	386,5	18,66						213	197
	SL	336,8	16,11	379,2	18,30						220	201
0404	A	399,8	19,12	426,7	20,60	A3					193	177
	K	382,4	18,29	414,9	20,03						201	183
	SL	370,6	17,72	420,1	20,28						206	180
0446	A	446,5	21,35	492,5	23,77	B1	LNTE 80-160/92/2	2	17	9,200	210	184
	K	430,6	20,59	469,4	22,66						217	196
	SL	409,4	19,58	470,8	22,73						227	196
0506	A	500,0	23,91	531,0	25,63	C1	LNTE 80-160/110/2	2	20	11,00	221	201
	K	475,7	22,75	512,7	24,75						233	212
	SL	444,0	21,23	511,1	24,67						248	213
0526	A	525,8	25,14	573,6	27,69	C2					227	200
	K	516,4	24,70	560,2	27,04						231	207
	SL	486,6	23,27	552,0	26,65						245	211
0546	A	543,5	25,99	596,0	28,77	C3					218	187
	K	533,6	25,52	579,9	27,99						223	196
	SL	506,1	24,20	568,8	27,46						236	202
0606	A	599,3	28,66	640,0	30,89	D1	LNTE 100-160/150/2	2	27	15,00	222	206
0708	A	696,6	33,31	752,7	36,34	E1	LNTE 100-160/185/2	2	33	18,50	257	237
0738	A	724,8	34,66	794,7	38,36	E2					262	240
0768	A	762,0	36,44	825,4	39,84	E3					252	230
0808	A	799,2	38,22	853,3	41,19	E4					241	220

(1) Values refer to nominal conditions

CH Cooling mode

HP HP mode

Pf Cooling capacity unit (Cooling mode)

Pt Heating capacity unit (Heating mode)

Q Plant (side) exchanger water flow

F.L.I. Pump power input

F.L.A. Pump running current

HU Pump residual pressure head (Units with hydronic group without mains filter)

HEAT EXCHANGER USER SIDE - U - 2 PUMPS 2P HH (VAR SPEED)

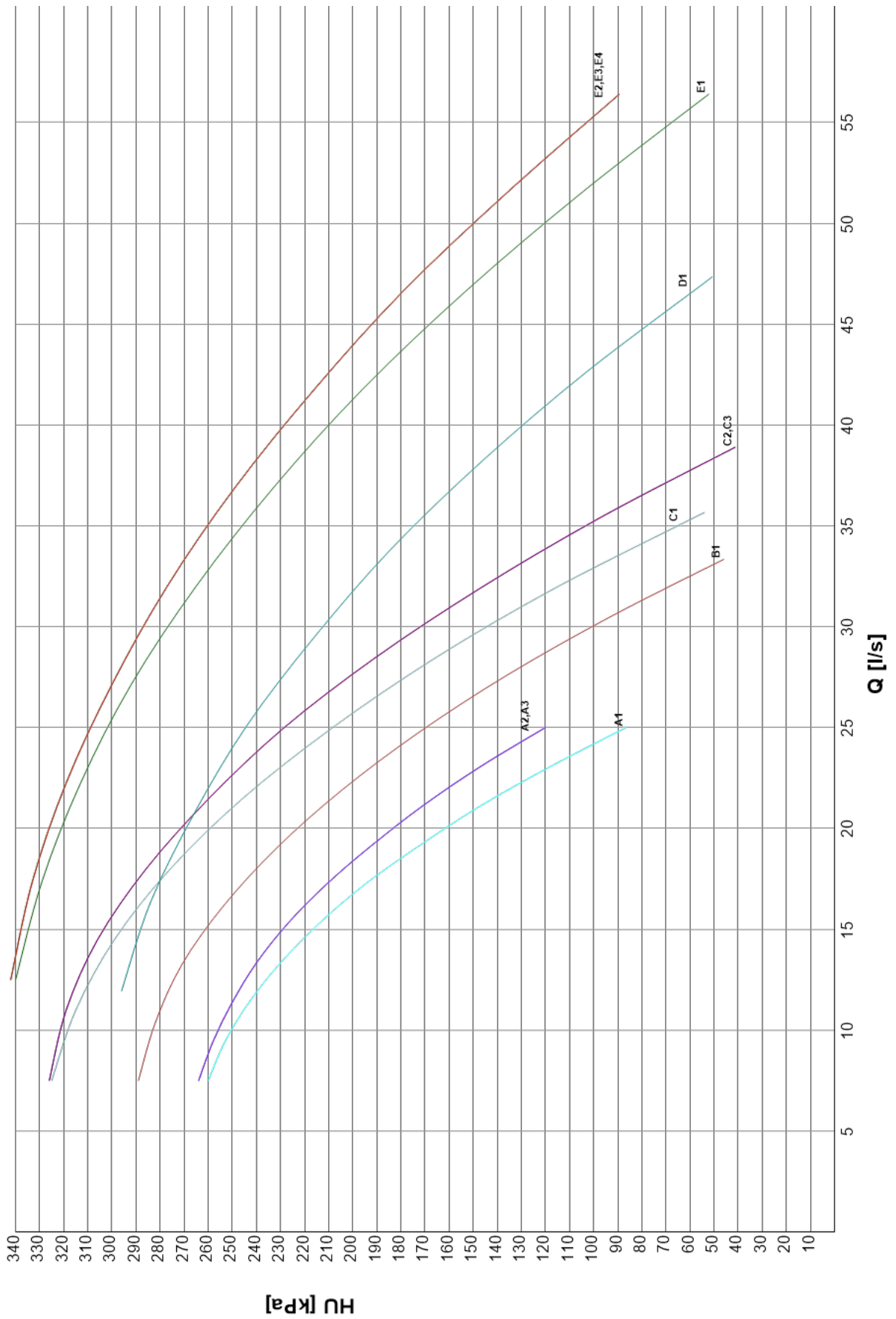

HYDRONIC GROUP

Data Book
 NX2-N-G06 0344 - 0808_202105_EN R454B

HEAT EXCHANGER USER SIDE - U - 2 PUMPS 2P LH (FIX SPEED)

SIZE		CH		HP		Curve	PUMP			CH	HP	
		Pfgross	Qfgross	Ptgross	Qcdgross		Model	N.	F.L.A.	F.L.I.	HU	HU
		[kW] (1)	[l/s] (1)	[kW] (1)	[l/s] (1)			Pole	[A]	[kW]	[kPa]	[kPa]
0344	A	345,3	16,51	376,3	18,17	A1	LNTE 65-125/55/2	2	11	5,500	149	123
	K	334,7	16,01	364,7	17,60						156	132
	SL	316,4	15,13	362,0	17,47						169	134
0364	A	361,5	17,29	397,2	19,17	A2	LNTE 65-125/55/2	2	11	5,500	154	126
	K	355,0	16,98	386,5	18,66						158	134
	SL	336,8	16,11	379,2	18,30						169	139
0404	A	399,8	19,12	426,7	20,60	B1	LNTE 65-125/55/2	2	11	5,500	113	102
	K	382,4	18,29	414,9	20,03						119	107
	SL	370,6	17,72	420,1	20,28						123	105
0446	A	446,5	21,35	492,5	23,77	B2	LNTE 65-125/55/2	2	11	5,500	110	92,0
	K	430,6	20,59	469,4	22,66						115	101
	SL	409,4	19,58	470,8	22,73						122	100
0506	A	500,0	23,91	531,0	25,63	B3	LNTE 65-125/55/2	2	11	5,500	90,9	76,3
	K	475,7	22,75	512,7	24,75						100	84,0
	SL	444,0	21,23	511,1	24,67						111	84,6
0526	A	525,8	25,14	573,6	27,69	C1	LNTE 65-125/55/2	2	11	5,500	127	109
	K	516,4	24,70	560,2	27,04						130	114
	SL	486,6	23,27	552,0	26,65						139	116
0546	A	543,5	25,99	596,0	28,77	C2	LNTE 65-125/55/2	2	11	5,500	121	100
	K	533,6	25,52	579,9	27,99						124	106
	SL	506,1	24,20	568,8	27,46						133	111
0606	A	599,3	28,66	640,0	30,89	C3	LNTE 65-125/55/2	2	11	5,500	109	91,5
0708	A	696,6	33,31	752,7	36,34	D1	LNTE 100-160/110/2	2	20	11,00	149	127
0738	A	724,8	34,66	794,7	38,36	D2	LNTE 100-160/110/2	2	20	11,00	154	128
0768	A	762,0	36,44	825,4	39,84	E1	LNTE 100-160/150/2	2	27	15,00	205	182
0808	A	799,2	38,22	853,3	41,19	E2	LNTE 100-160/150/2	2	27	15,00	193	172

(1) Values refer to nominal conditions

CH Cooling mode

HP HP mode

Pf Cooling capacity unit (Cooling mode)

Pt Heating capacity unit (Heating mode)

Q Plant (side) exchanger water flow

F.L.I. Pump power input

F.L.A. Pump running current

HU Pump residual pressure head (Units with hydronic group without mains filter)

HEAT EXCHANGER USER SIDE - U - 2 PUMPS 2P LH (FIX SPEED)

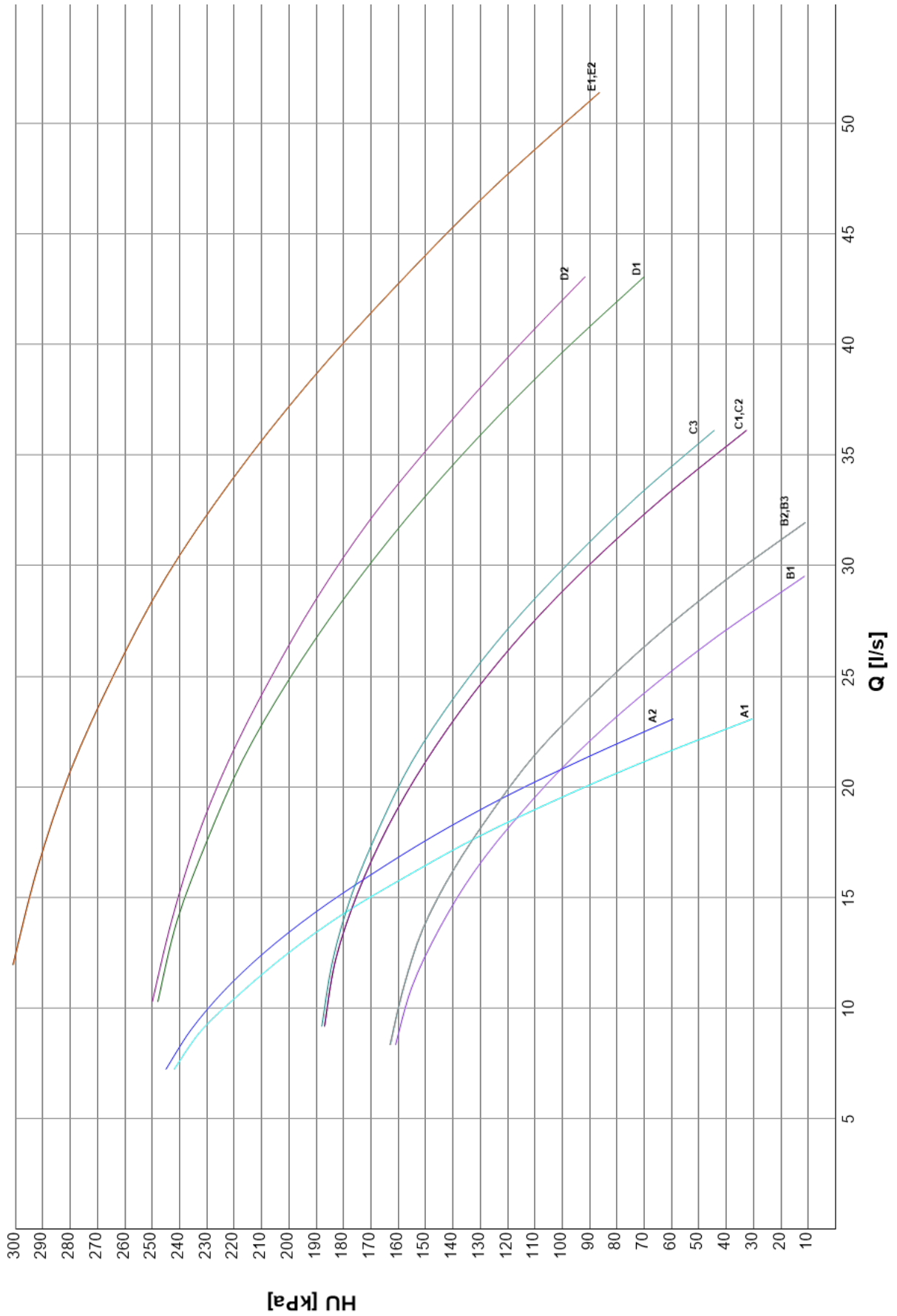

HYDRONIC GROUP

Data Book
NX2-N-G06 0344 - 0808_202105_EN R454B

HEAT EXCHANGER USER SIDE - U - 2 PUMPS 2P LH (VAR SPEED)

SIZE		CH		HP		PUMP				CH	HP	
		Pfgross	Qfgross	Ptgross	Qcdgross	Curve	Model	N.	F.L.A.	F.L.I.	HU	HU
		[kW] (1)	[l/s] (1)	[kW] (1)	[l/s] (1)			Pole	[A]	[kW]	[kPa]	[kPa]
0344	A	345,3	16,51	376,3	18,17	A1	LNTE 65-125/55/2	2	11	5,500	149	123
	K	334,7	16,01	364,7	17,60						156	132
	SL	316,4	15,13	362,0	17,47						169	134
0364	A	361,5	17,29	397,2	19,17	A2	LNTE 65-125/55/2	2	11	5,500	154	126
	K	355,0	16,98	386,5	18,66						158	134
	SL	336,8	16,11	379,2	18,30						169	139
0404	A	399,8	19,12	426,7	20,60	B1	LNTE 65-125/55/2	2	11	5,500	113	102
	K	382,4	18,29	414,9	20,03						119	107
	SL	370,6	17,72	420,1	20,28						123	105
0446	A	446,5	21,35	492,5	23,77	B2	LNTE 65-125/55/2	2	11	5,500	110	92,0
	K	430,6	20,59	469,4	22,66						115	101
	SL	409,4	19,58	470,8	22,73						122	100
0506	A	500,0	23,91	531,0	25,63	B3	LNTE 65-125/55/2	2	11	5,500	90,9	76,3
	K	475,7	22,75	512,7	24,75						100	84,0
	SL	444,0	21,23	511,1	24,67						111	84,6
0526	A	525,8	25,14	573,6	27,69	C1	LNTE 65-125/55/2	2	11	5,500	127	109
	K	516,4	24,70	560,2	27,04						130	114
	SL	486,6	23,27	552,0	26,65						139	116
0546	A	543,5	25,99	596,0	28,77	C2	LNTE 65-125/55/2	2	11	5,500	121	100
	K	533,6	25,52	579,9	27,99						124	106
	SL	506,1	24,20	568,8	27,46						133	111
0606	A	599,3	28,66	640,0	30,89	C3	LNTE 65-125/55/2	2	11	5,500	109	91,5
0708	A	696,6	33,31	752,7	36,34	D1	LNTE 100-160/110/2	2	20	11,00	149	127
0738	A	724,8	34,66	794,7	38,36	D2	LNTE 100-160/110/2	2	20	11,00	154	128
0768	A	762,0	36,44	825,4	39,84	E1	LNTE 100-160/150/2	2	27	15,00	205	182
0808	A	799,2	38,22	853,3	41,19	E2	LNTE 100-160/150/2	2	27	15,00	193	172

(1) Values refer to nominal conditions

CH Cooling mode

HP HP mode

Pf Cooling capacity unit (Cooling mode)

Pt Heating capacity unit (Heating mode)

Q Plant (side) exchanger water flow

F.L.I. Pump power input

F.L.A. Pump running current

HU Pump residual pressure head (Units with hydronic group without mains filter)

HEAT EXCHANGER USER SIDE - U - 2 PUMPS 2P LH (VAR SPEED)

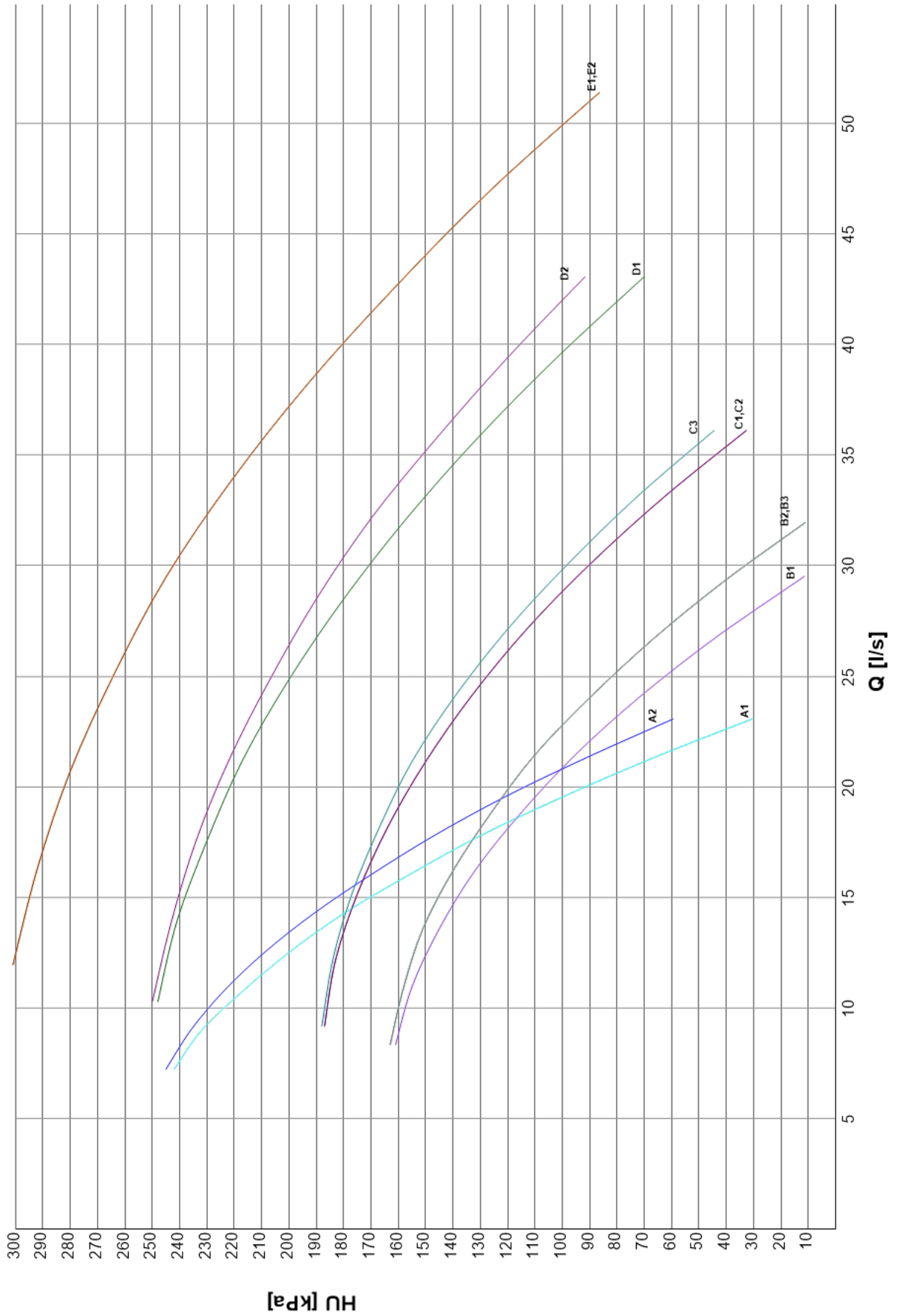

15.1 Variable flow control

Pump energy consumption significantly impacts plant running costs, but it can be considerably reduced thanks to the use of variable speed pumps (inverter driven pumps), capable of adjusting the water flow rate according to the actual plant thermal load.

Mitsubishi Electric Hydronics & Cooling Systems has developed the VPF control series (Variable Primary Flow), that provides different water flow regulation logics specifically devoted to various hydraulic plant solutions: only a primary circuit, primary and secondary circuits, single unit or multi-unit systems controlled with external controller (Manager 3000, ClimaPRO).

The VPF systems adjust the pump speeds on the basis of the plant's thermal load and optimize the unit's thermoregulation algorithm for variable flow operation, in a dynamic and simultaneous way. This ensures the highest energy savings, stable operation, and complete reliability.

VPF SYSTEM (delta P control) For plants with only a primary circuit

VPF - Plant and unit requirements

The VPF logic provides the variable flow control for the plant's primary circuit.

- Type of plant: primary circuit only, that feeds hydronic terminals fitted with a 2-way regulating valve
- Hydronic module: modulating regulation devices (0-10V signal) or variable speed pumps
- Unit thermoregulation: control of the leaving water temperature
- Monitored parameter: delta P on relevant users' hydronic terminal

Plant diagram for single unit system

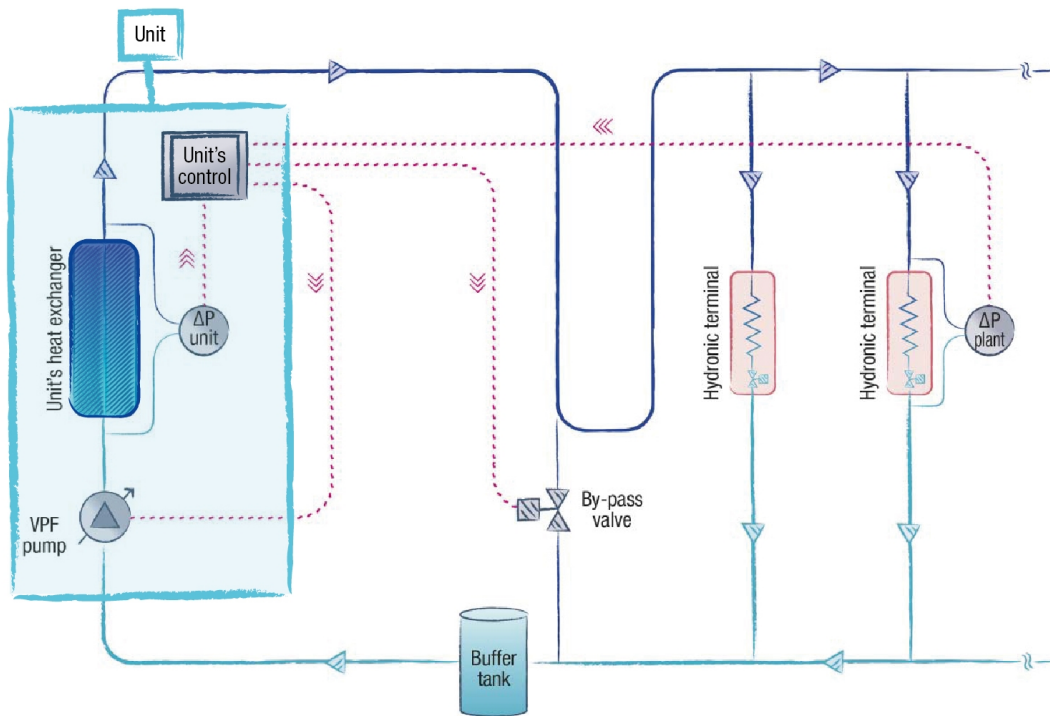

Plant diagram for multi-unit with external control system (Manager3000 or ClimaPRO)

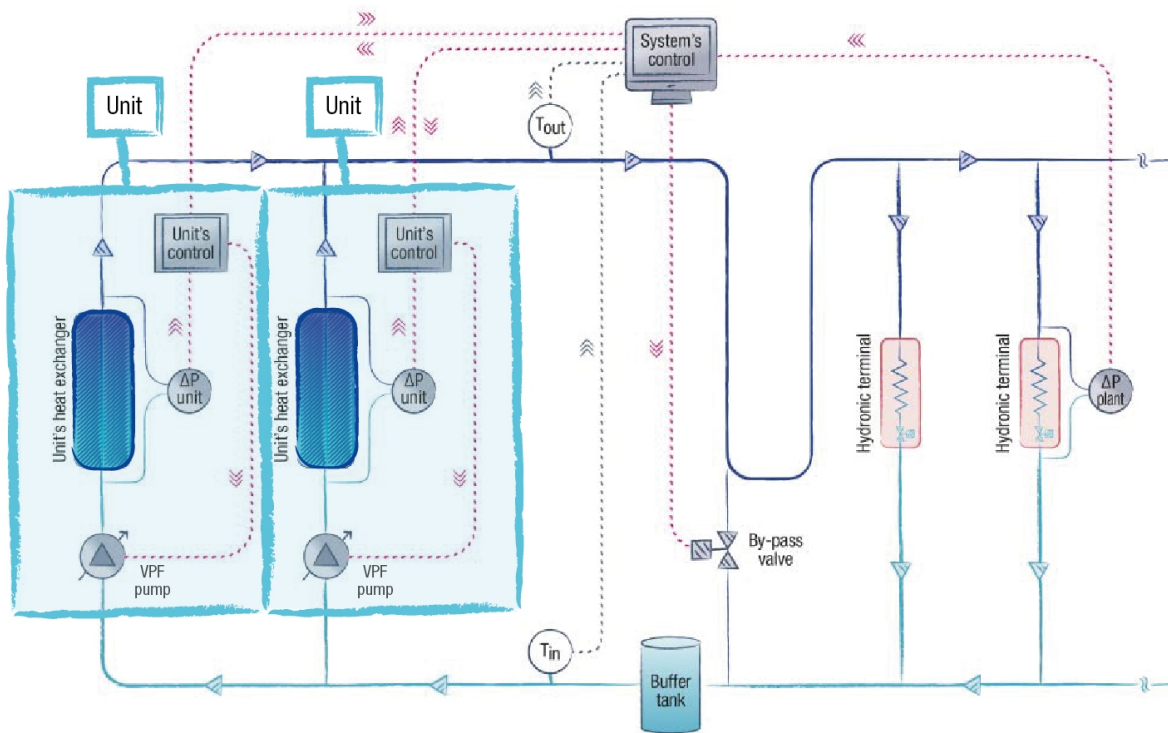

VPF - Operating logic

Water flow regulation

The VPF system monitors the differential pressure on the plant side (ΔP) and adjusts the pump speed in order to keep it within a defined range (ΔP_{min} ΔP_{max}).

- If $\Delta P_{min} \leq \Delta P \leq \Delta P_{max}$

The plant water flow is appropriate to the thermal load, the pump speed is kept constant.

- If $\Delta P > \Delta P_{max}$

The plant water flow exceeds what is necessary to properly cover the thermal load, the pump speed is reduced to save pump energy.

- If $\Delta P < \Delta P_{min}$

The plant water flow is too low to ensure the proper feed to the hydronic terminals, the pump speed is increased.

With the VPF system, the water flow can be reduced to 50% of the unit nominal water flow, with regards to the selection conditions, provided that the minimum water flow required by the unit's heat exchanger is respected (the control of the heat exchanger's minimum water flow is described below).

The pump speed regulation is performed with little progressive adjustments while continuously monitoring the values of both the delta P on the plant side and the water temperature on the heat exchanger. The absence of abrupt water flow changes prevents fluctuation due to possible conflicts with the unit's thermoregulation function (compressor regulation).

Control of the unit's minimum water flow

Under no circumstances can the primary circuit water flow be reduced below the minimum water flow required by the unit's heat exchanger.

The monitoring of the unit's water flow is performed through a factory installed differential pressure transducer on the unit's heat exchanger.

If the differential pressure on the plant side requests a users' water flow lower than the unit's minimum water flow, the VPF system commands the gradual opening of the hydraulic by-pass valve (safety function). This ensures that the minimum water flow required by the unit's heat exchanger is always provided. As soon as the hydronic terminals request an increase of the water flow ($\Delta P < \Delta P_{min}$), the VPF closes the by-pass valve.

Multi-unit systems

The VPF control logic is also the same for multi-unit systems.

The plant side differential pressure transducer reading and the by-pass valve opening are managed by the multi-unit control system (Manager3000, ClimaPRO).

Each unit autonomously adjusts its pump speed on the basis of the information provided by the multi-unit control system.

When the plant load requests the activation of a stand-by unit, the multi-unit control system calculates the starting speed of its pump in order to avoid excessive water flow variation of the running units.

VPF - Devices and installation

Device	Accessory name		
	VPF (w/o DP)(SU, MM_PR) ⁽¹⁾	VPF (w DP)(SU, MM_PR) ⁽²⁾	VPF (M3000, CPRO, MM_N-PR) ⁽³⁾
Differential pressure transducer on the unit's heat exchanger and related controller expansion board	Factory installed	Factory installed	Factory installed
Controller expansion board to read the plant side differential pressure transducer (4-20mA signal) and manage the hydraulic by-pass valve opening (0-10V signal)	Factory installed	Factory installed	Factory installed on the multi-unit external control system (Manager3000, ClimaPRO) ⁽⁵⁾
Plant side differential pressure transducer	Not included (the supply is the customer's responsibility) ⁽⁴⁾	Factory supplied, installation is the client's responsibility ⁽⁴⁾⁽⁵⁾	Factory supplied with the multi-unit external control system (Manager3000, ClimaPRO); installation is the client's responsibility ⁽⁴⁾⁽⁶⁾
Plant side hydraulic by-pass valve	Not included (the supply is the customer's responsibility) ⁽⁷⁾	Not included (the supply is the customer's responsibility) ⁽⁷⁾	Not included (the supply is the customer's responsibility) ⁽⁷⁾

(1) VPF for unit without plant differential pressure transducer included (for single unit plant)

(2) VPF for unit with plant differential pressure transducer included (for single unit plant)

(3) VPF for multi-unit plant with external controller (Manager3000, ClimaPRO)

(4) It is recommended to install the differential pressure transducer on the most hydraulically critical hydronic terminal, to ensure it has a proper water flow in any load condition.

(5) Technical features of the differential pressure transducer supplied:

Model: Huba Control 692.9 120071C1

Pressure range: 0 ... + 1 bar

Output: 4-20mA

Electrical connection: DIN EN 175301-803-A (IP 65)

Pressure connection adapters: male threaded G 1/8"

(6) It is the customer's responsibility to configure the multi-unit control system (Manager3000, ClimaPRO) with option VPF.

(7) See attached table for information on the hydraulic by-pass design.

The following table provides the indications for a correct hydraulic by-pass design.

Heat exchanger minimum flow (m ³ /h) ⁽¹⁾	Minimum by-pass diameter	Minimum by-pass valve diameter	Suggested valve model	Kvs	Suggested actuator model
From 19 to 30	DN50 (2")	DN50 (2")	VVG41.50	40	SKB60
Up to 37	DN65 (2" ½)	DN65 (2" ½)	VVF31.65	49	SKB60
Up to 60	DN80 (3")	DN80 (3")	VVF31.80	78	SKB60
Up to 95	DN100 (4")	DN100 (4")	VVF31.90	124	SKC60
Up to 150	DN125 (5")	DN125 (5")	VVF31.91	200	SKC60
Up to 230	DN150 (6")	DN150 (6")	VVF31.92	300	SKC60

(1) In case of a multi-unit system, the unit with the highest minimum water flow should be the reference.

VPF.D SYSTEM (delta T control)

For plants with primary and secondary circuits separated by a hydraulic decoupler.

VPF.D - Plant and unit requirements

The VPF.D logic provides the variable flow control for the plant's primary circuit.

- Type of plant: primary and secondary circuits separated by a hydraulic decoupler
- Hydronic module: modulating regulation devices (0-10V signal) or variable speed pumps
- Unit thermoregulation: control of the leaving water temperature
- Monitored parameter: delta T on primary circuit

ATTACHMENTS

Data Book
NX2-N-G06 0344 - 0808_202105_EN R454B

Plant diagram for single unit system

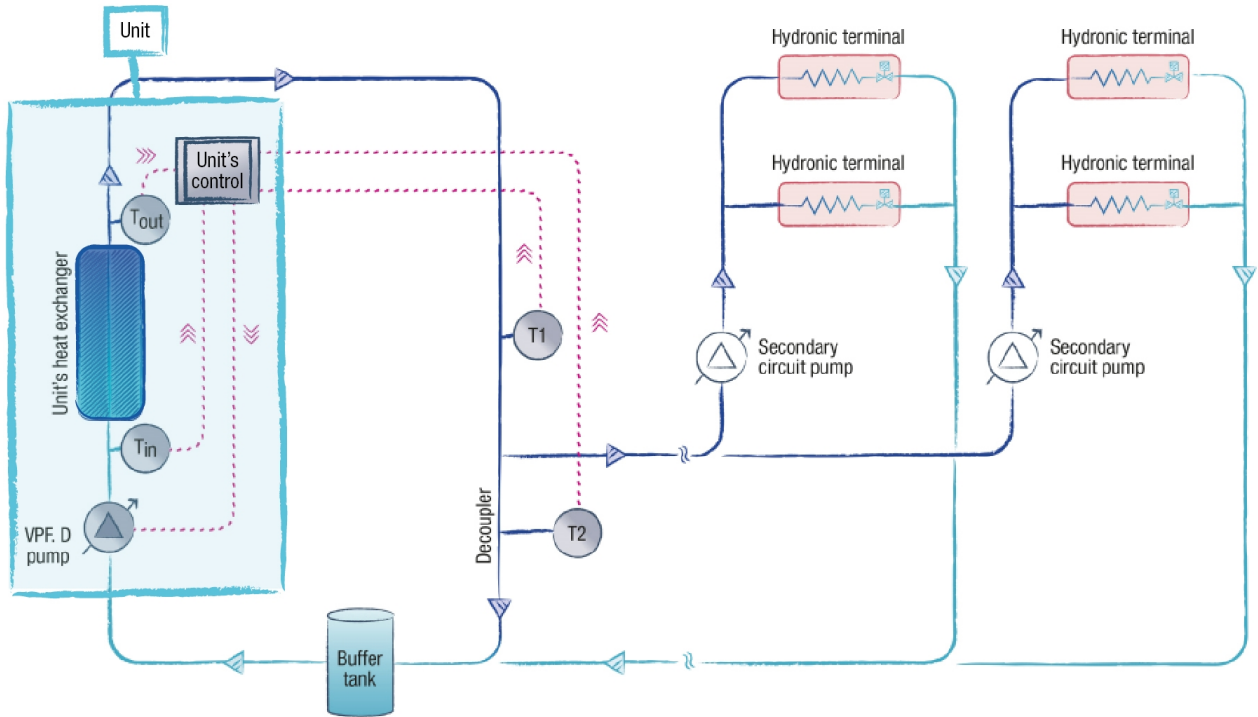

Plant diagram for multi-unit with external control system (Manager3000 or ClimaPRO)

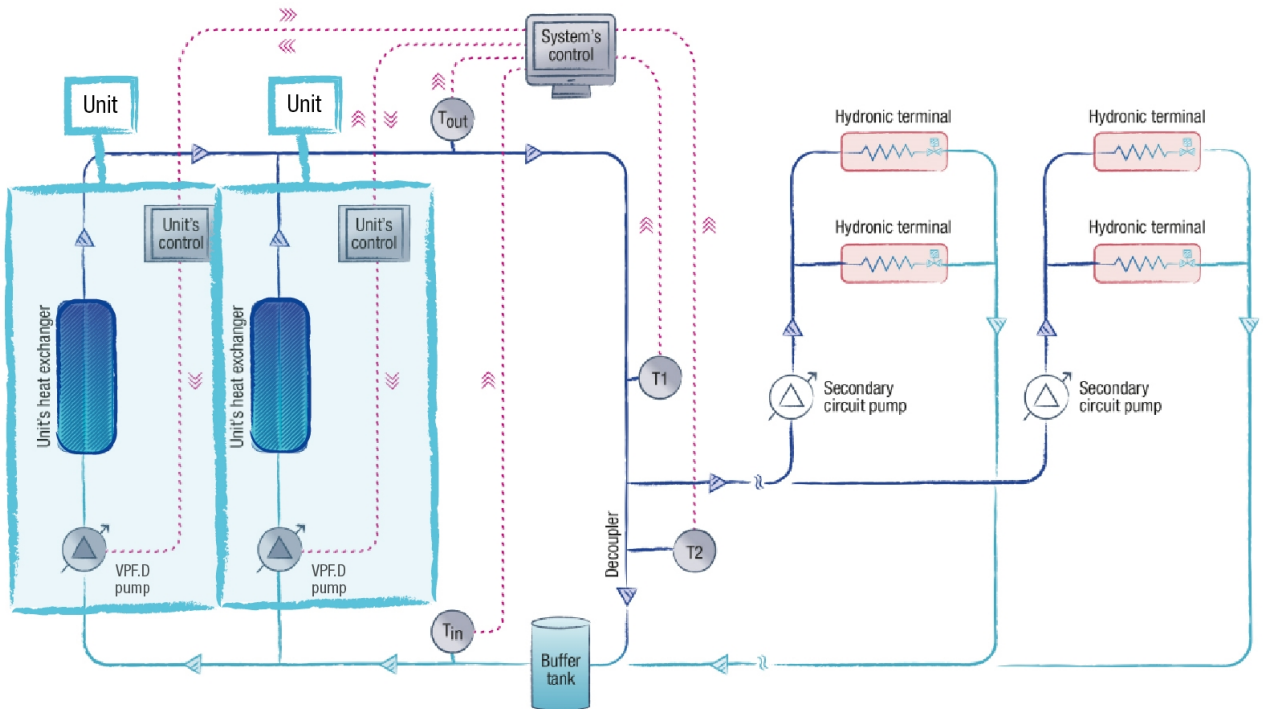

VPF.D - Operating logic

Water flow regulation

The VPF.D system monitors the temperature difference of the primary circuit (ΔT) (that corresponds to the temperature difference of the unit's heat exchanger in the case of a single unit system), and adjusts the primary circuit's pump speed in order to keep it within a defined range ($\Delta T_{min} \leq \Delta T \leq \Delta T_{max}$). The secondary circuit water flow is completely independent and is to be managed by the client.

- If $\Delta T_{min} \leq \Delta T \leq \Delta T_{max}$

The plant water flow is appropriate to the thermal load, the pump speed is kept constant.

- If $\Delta T < \Delta T_{min}$

The plant water flow exceeds what is necessary to properly cover the thermal load, the pump speed is reduced to save pump energy.

- If $\Delta T > \Delta T_{max}$

The plant water flow is too low to ensure the proper feed to the users, the pump speed is increased.

To prevent the returning water of the secondary circuit from recirculating through the decoupler and mixing with the delivery water, which would cause serious plant regulation problems, the VPF.D provides a safety function based on the temperatures, which are detected by two probes on the plant side: T1 on the unit delivery line and T2 on the hydraulic decoupler. If during the water flow regulation of the circuits, the flow direction in the decoupler reverses (detected temperatures $T1 < T2$), the system forces a quick increase of the primary water flow until the correct direction of the flow in the decoupler is restored (detected temperatures $T1 = T2$).

With the VPF.D system, the water flow can be reduced to 50% of the unit nominal water flow, with regards to the selection conditions, provided that the minimum water flow required by the unit's heat exchanger is respected (the control of the heat exchanger's minimum water flow is described below).

The pump speed regulation is performed with little progressive adjustments while continuously monitoring the values of both the temperature difference on the primary circuit and the temperatures of the probes T1 and T2. The absence of abrupt water flow changes prevents fluctuation due to possible conflicts with the unit's thermoregulation function (compressor regulation).

Control of the unit's minimum water flow

Under no circumstances can the primary circuit water flow be reduced below the minimum water flow required by the unit's heat exchanger.

The unit's minimum water flow is ensured by setting the minimum pump speed (service menu parameter).

Multi-unit systems

The VPF.D control logic is also the same for multi-unit systems.

The reading of the temperature difference on the primary circuit and the reading of the temperature probes T1 and T2 is managed by the multi-unit control system (Manager3000, ClimaPRO).

Each unit autonomously adjusts its pump speed on the basis of the information provided by the multi-unit control system.

When the plant load requests the activation of a stand-by unit, the multi-unit control system calculates the starting speed of its pump in order to avoid excessive water flow variation of the running units.

ATTACHMENTS

Data Book
 NX2-N-G06 0344 - 0808_202105_EN R454B

VPF.D - Devices and installation

Dispositivo	Accessory name	
	VPF.D (SU, MM_PR) ⁽¹⁾	VPF.D(M3000, CPRO, MM_N-PR) ⁽²⁾
2 plant side NTC temperature sensors and related controller expansion board	Factory supplied (probes supplied without wells), installation is the client's responsibility ⁽³⁾	Factory supplied with the multi-unit external control system, Manager3000 or ClimaPRO (probes supplied without wells); installation is the client's responsibility ⁽³⁾⁽⁴⁾

(1) VPF.D for single unit plant

(2) VPF.D for multi-unit plant with external controller (Manager3000 or ClimaPRO)

(3) It is recommended to install the temperature probes as shown in the enclosed plant diagrams (T1 on the unit delivery line, T2 on the hydraulic decoupler)

(4) It is the customer's responsibility to configure the multi-unit control system (Manager3000, ClimaPRO) with option VPF.D.

The following table provides the indications for a correct hydraulic decoupler design.

Heat exchanger minimum flow (m ³ /h) ⁽¹⁾	Minimum hydraulic decoupler diameter
From 25 to 40	DN65 (2" ½)
Up to 60	DN80 (3")
Up to 100	DN100 (4")
Up to 150	DN125 (5")
Up to 225	DN150 (6")
Up to 375	DN200 (8")

(1) In case of a multi-unit system, the unit with the highest minimum water flow should be the reference.

**MITSUBISHI ELECTRIC
HYDRONICS & IT COOLING SYSTEMS S.p.A.**

Head Office:

Via Caduti di Cefalonia 1 - 36061 Bassano del Grappa (VI) - Italy

Tel (+39) 0424 509 500 - Fax (+39) 0424 509 509

www.melcohit.com