

2. EXTERNAL DIMENSIONS

Floor standing (Exposed 2-way/Exposed/Concealed type)

PFFY-P20, 25, 32, 40, 50, 63VLRMM-E

Unit : mm

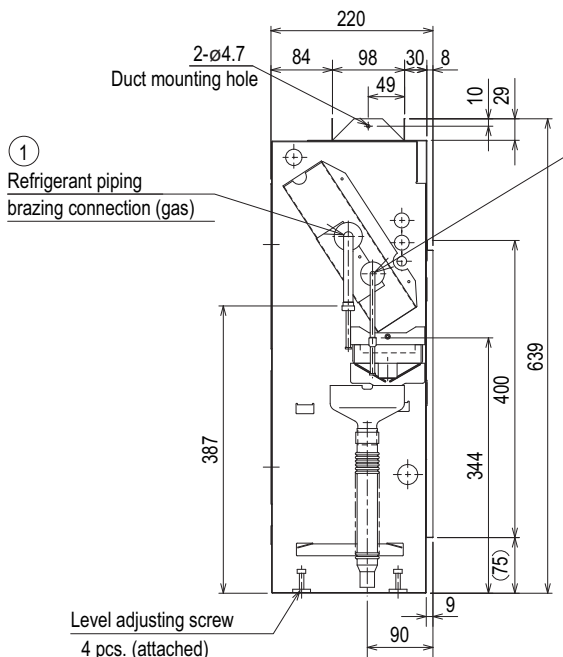
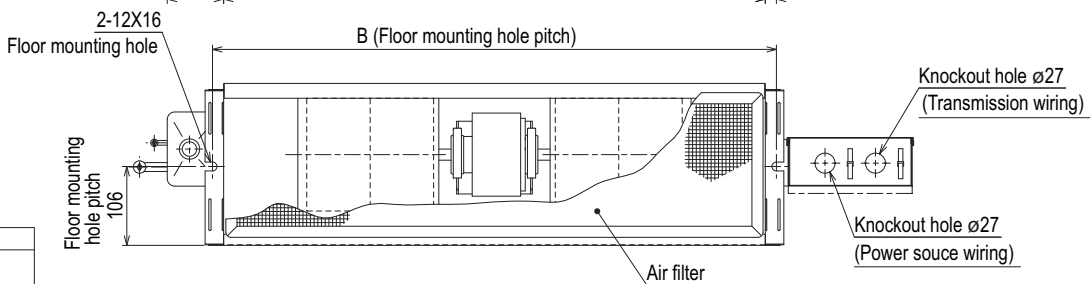
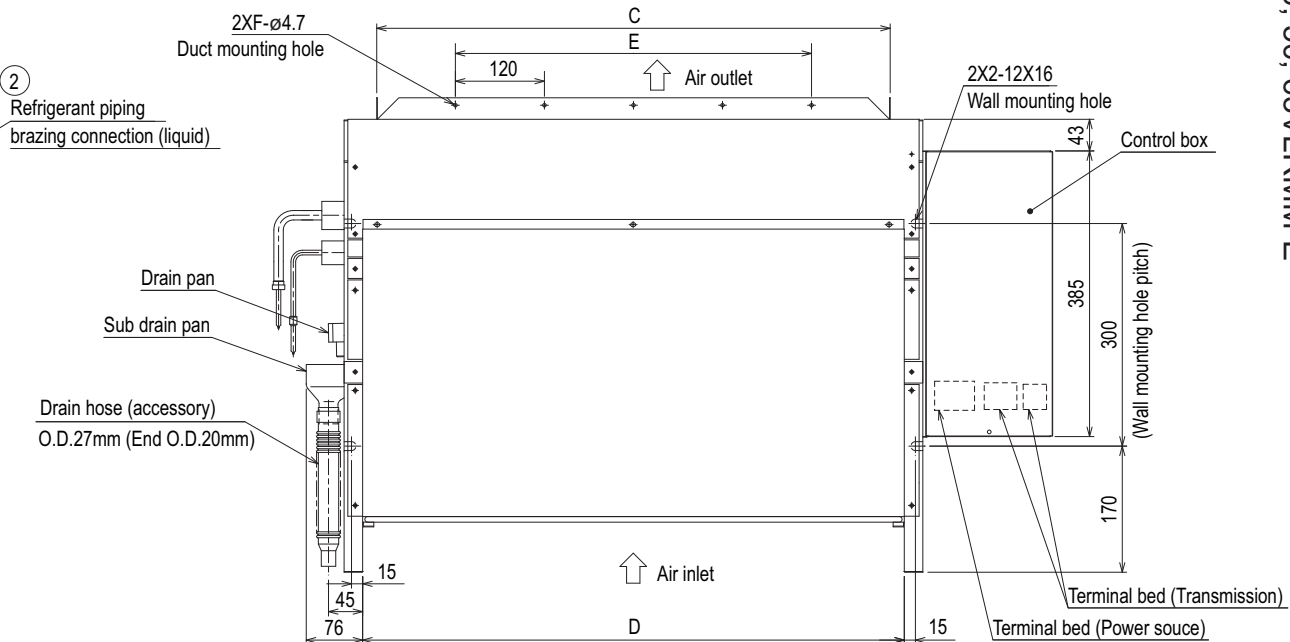
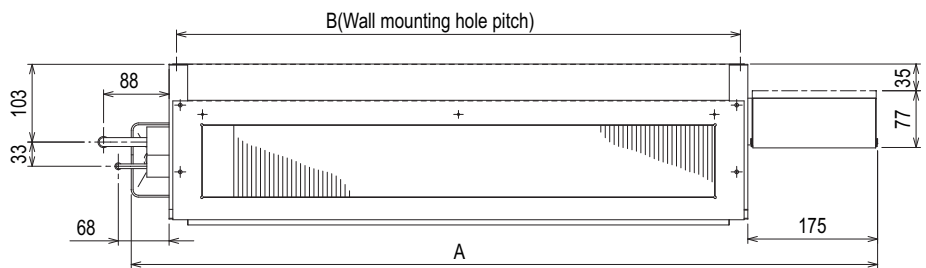

Dimensions

Model	A	B	C	D	E	F	① Gas pipe	② Liquid pipe
PFFY-P20VLRMM-E	886	640	572	610	360	4	ø12.7	ø6.35
PFFY-P25VLRMM-E								
PFFY-P32VLRMM-E								
PFFY-P40VLRMM-E	1006	760	692	730	480	5	ø15.88	ø9.52
PFFY-P50VLRMM-E								
PFFY-P63VLRMM-E								

PFFY-P-VKM-E2, VLRMM-E, VLRM-E, VLEM-E, VLRMM-E